

\*All measurements in mm

## FEATURES

- Fixed Frame Plate
- Upper Carrying Bar
- Lower Guiding Bar
- Support Column
- Movable Pressure Plate
- Clip-On EPDM Gaskets
- Tightening Bolts and Nuts
- Adjustable Feet

No. of plates	30
No. of effective plates	28
No. of passes	4
Plate pack dimensions A Measure	84 mm

## CAUTION: DO NOT TIGHTEN BELOW MINIMUM DIMENSION

	Beer wort	Water
Mass flow rate	1028 Kg/h	990.9 Kg/h
Inlet temperature	93.3°C (199.9°F)	10°C (50.0°F)
Outlet temperature	21.1°C (69.9°F)	76.6°C (169.9°F)
Pressure drop (Perm/Calc)	80.0/26.3 kPa	80.0/24.1 kPa

Heat exchanged	40.46 kW
Heat transfer area	1.05 m <sup>2</sup>
O.H.T.C clean conditions	3613 W/ (m <sup>2</sup> *K)
O.H.T.C service	3293 W/ (m <sup>2</sup> *K)
Fouling Resistance* 10000	0.0 m <sup>2</sup> *K/W
Additional Excess Surface	10%
Mean Temperature	13.7 K

## CONNECTION TYPES

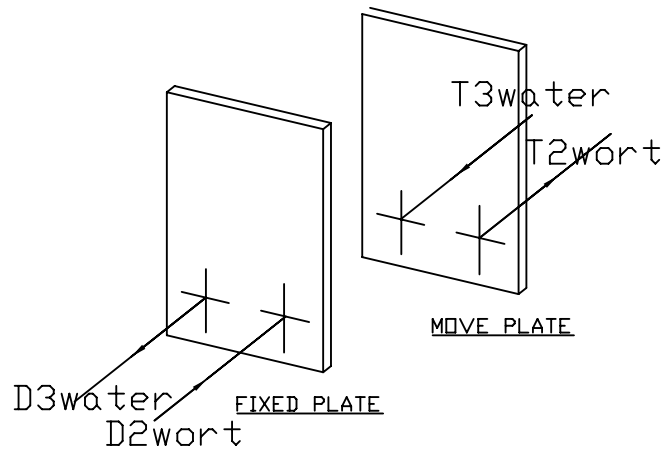

## CONNECTION TYPES

