

*All measurements in mm

FEATURES

- Fixed Frame Plate
- Upper Carrying Bar
- Lower Guiding Bar
- Support Column
- Movable Pressure Plate
- Clip-On EPDM Gaskets
- Tightening Bolts and Nuts
- Adjustable Feet

No. of plates	18
No. of effective plates	16
No. of passes	4
Plate pack dimensions A Measure	50.5 mm

CAUTION: DO NOT TIGHTEN BELOW MINIMUM DIMENSION

	Beer wort	Water
Mass flow rate	1028 Kg/h	990.9 Kg/h
Inlet temperature	93.3°C (212°F)	10°C (54.9°F)
Outlet temperature	21°C (70°F)	76.6°C (169.9°F)
Pressure drop (Perm/Calc)	80.0/19.1 kPa	80.0/17.5 kPa

Heat exchanged	20.22 kW
Heat transfer area	0.63 m ²
O.H.T.C clean conditions	3155 W/ (m ² *K)
O.H.T.C service	2875 W/ (m ² *K)
Fouling Resistance* 10000	0.0 m ² *K/W
Additional Excess Surface	10%
Mean Temperature	13.7 K

CONNECTION LOCATIONS

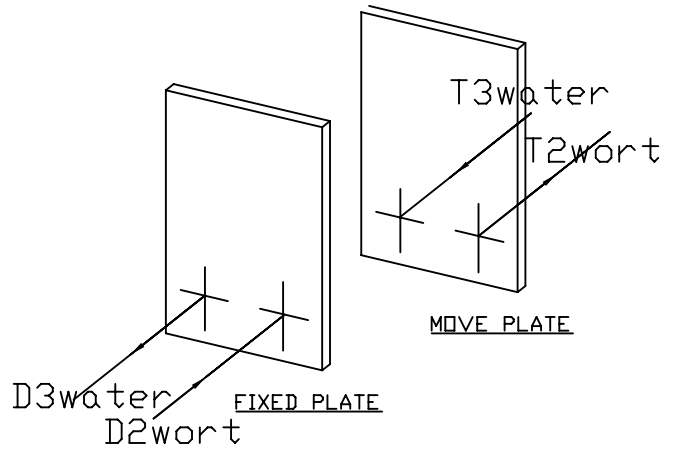

CONNECTION TYPES

