



CPE SYSTEMS INC



# C+114MD

## CENTRIFUGAL PUMP



The C+114 is CPE's next generation centrifugal pump targeted at small to medium applications. This pump takes the popular C114 pump and adds design improvements to increase capability and durability. It is attached to our efficient stainless steel washdown motor. The C+114 is designed to be a versatile pump in the food processing world.

## DESIGN

The C+114MD is the original C-series centrifugal pump re-imagined. It has kept the original casing design and popular external mechanical seal options, however, it features a collar that clamps down on the drive shaft over a full 360 degrees removing the minor wobble that can occur from set screwed shafts. The impeller pin was also replaced with a threaded impeller nut that fully secures the impeller in place; there are two specialized gaskets to seal the shaft and to still allow a CIP procedure to clean behind the impeller. The collar and bolted impeller reduce rattling sounds at lower speeds.

## SEALS

There are three seal types available for the C+114:

**D Seal:** Standard external mechanical seal.

**DG Seal:** External mechanical seal with a ceramic stationary seat.

**F Seal:** External mechanical seal with a water cascade.

## HORSEPOWER

Horsepower	*Max. Flow rate	*Shut Off Head
1 HP	75 GPM	65 ft
1.5 HP	100 GPM	75 ft
2 HP	125 GPM	75 ft
3 HP	150 GPM	75 ft

\* For specific duties, contact CPE.

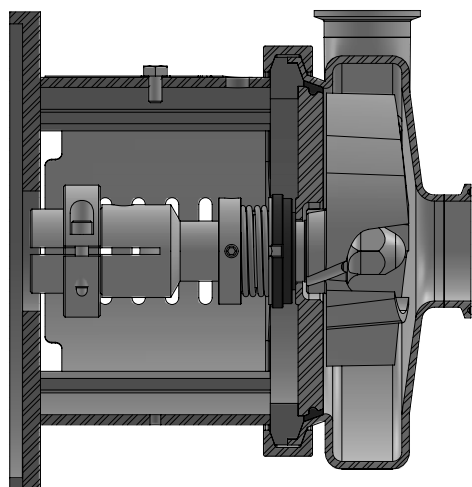

## TECHNICAL SPECIFICATIONS

### Materials

Parts in Contact With Product:	316L Stainless Steel
Other Steel Parts:	304 Stainless Steel
Gaskets in Contact With Product:	EPDM (Buna & Viton optional)
Weight Without Motor:	12 lbs

### Mechanical Seal

Rotary Seal:	Carbon or Silicon Carbide
Stationary Seal:	Stainless Steel or Ceramic/Silicon Carbide
External Surface Finish:	Bright Polish
Internal Surface Finish:	32 RA
Connection Type:	Tri-Clamp
Connection Size:	1.5" x 1.5"
Max. Impeller Diameter:	4"

### Motor

Type:	S.S Premium Efficiency
Motor Frame Size:	NEMA 56C C-Face
Speeds:	1750 & 3450 RPM

### Operating Limits

Nominal Pressure:	10 bar (145 PSI)
Temperature Range:	14°F (-10°C) - 248°F (120°C)
Maximum Flow:	150 GPM (90 m³/h)
Maximum Differential Head:	75 ft (23 m)
Maximum Speed:	3500RPM - 60Hz
Viscosity:	1200 cPs

### Optimum Operating System

Flow:	150 GPM
Head:	75 ft

### Approvals

Certification:	3A- Authorization #1537, 02-11 (centrifugal pumps) for CIP
----------------	--



# Capacity Curves

MODEL: C+114

Frequency: 60hz

RPM: 1750

Size: 1.5" x 1.5" x 4"

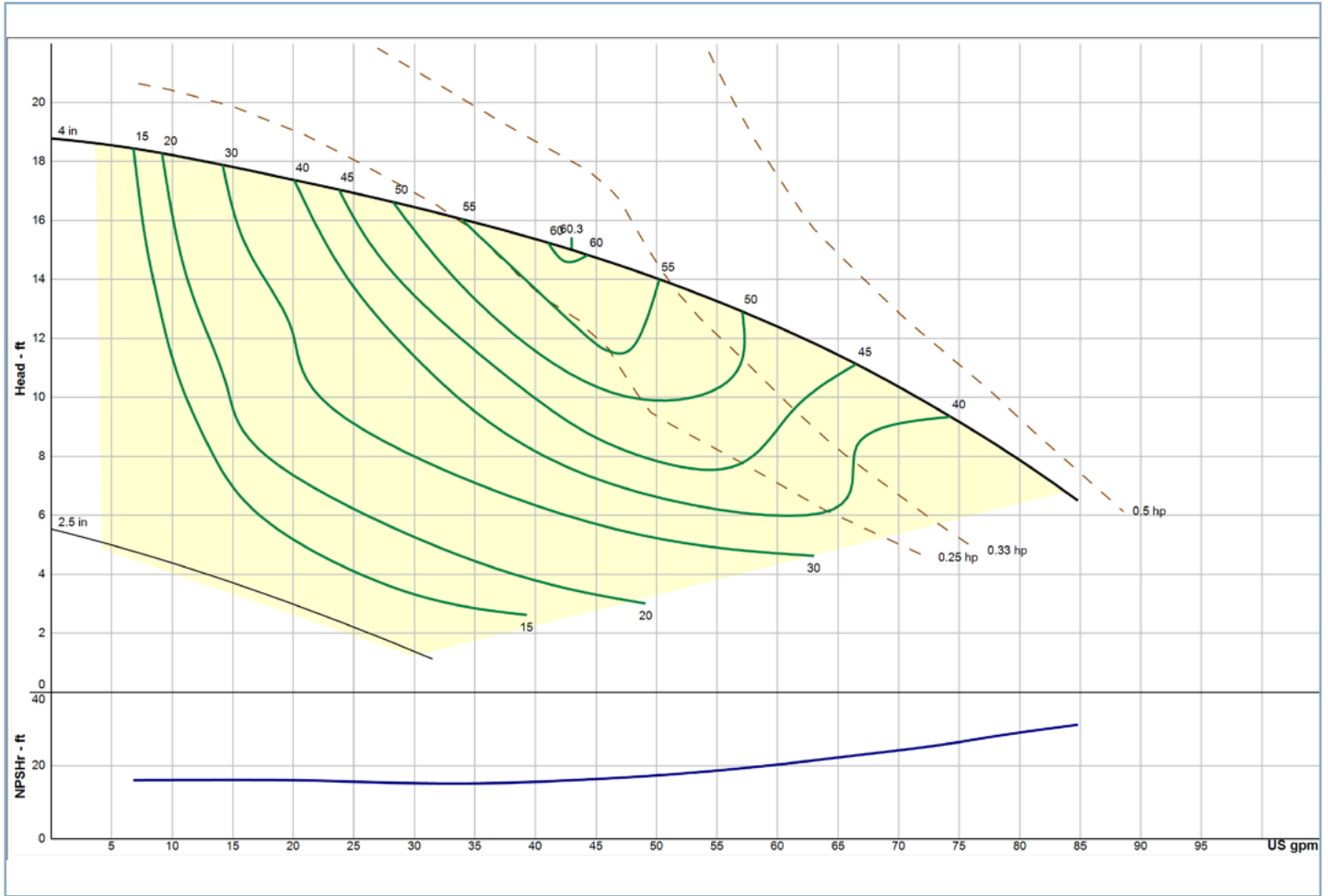



# Capacity Curves

MODEL: C+114

Frequency: 60hz

RPM: 3500

Size: 1.5" x 1.5" x 4"

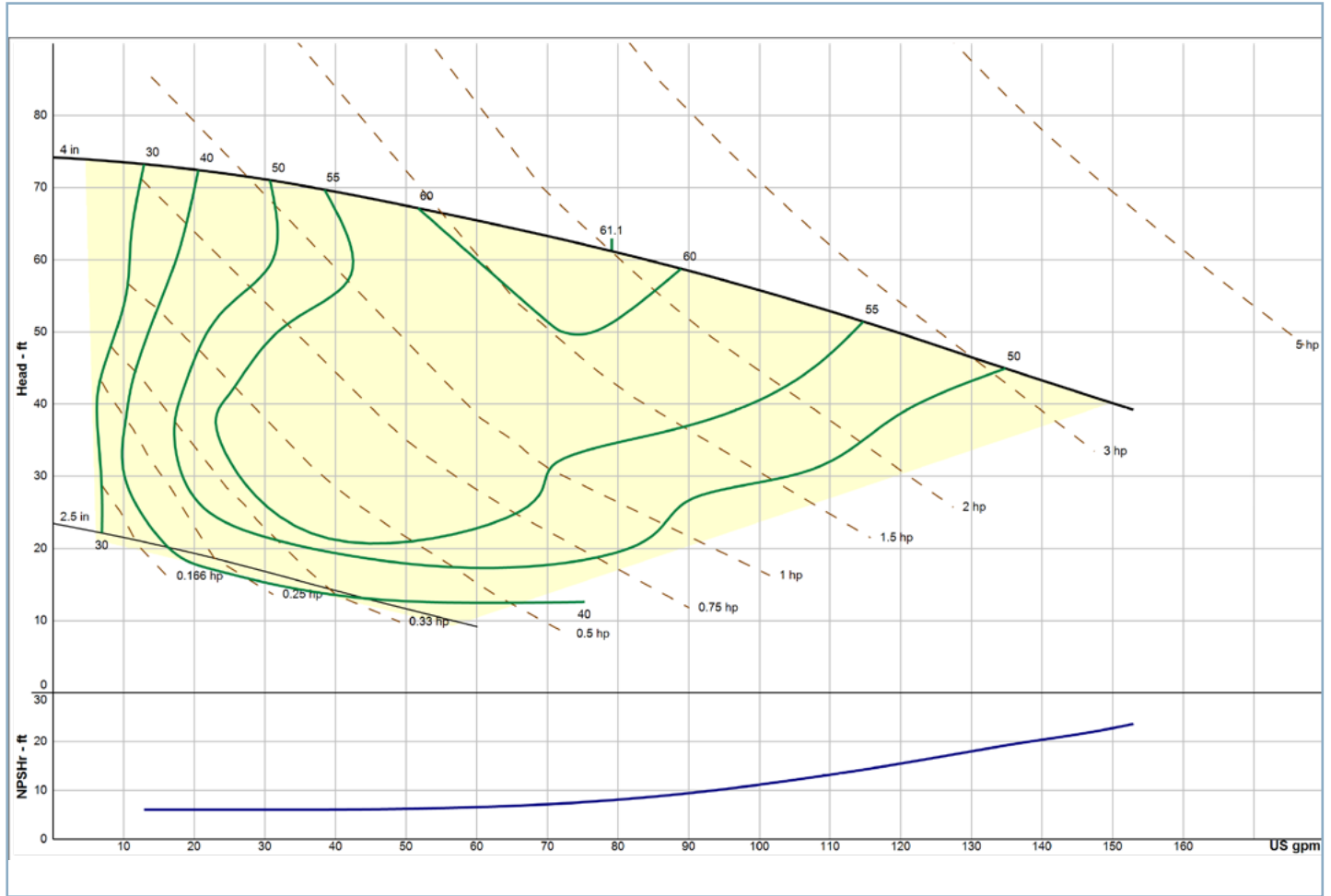



# Viscosity and Specific Gravity Table

Product	Specific Gravity	Viscosity
Acetic Acid		
5%	1.01	
10%	1.01	31.7 SSU @ 59°F
50%	1.06	33.0 SSU @ 59°F
80%	1.08	35.0 SSU @ 59°F
Animal Fat	0.9	130 SSU @ 115°F
		50 SSU @ 200°F
Barbecue Sauce	1.05	11,500 SSU @ 40-75°F
Beer	1.02	32 SSU @ 68°F
Blood - Animal	0.93-0.98	15,000 SSU @ 55°F
Butter	0.93-0.98	15,000 SSU @ 55°F
		440 SSU @ 90°F
		220 SSU @ 115°F
Coconut Oil	0.92	125 SSU @ 106°F
Corn Oil	0.92	135 SSU @ 130°F
		54 SSU @ 212°F
Corn Starch Solutions		
22 Baume	1.18	150 SSU @ 70°F
		130 SSU @ 100°F
24 Baume	1.2	600 SSU @ 70°F
		440 SSU @ 100°F
25 Baume	1.21	1400 SSU @ 70°F
		800 SSU @ 100°F
Cottage Cheese	1.02	4,300 SSU
Cream (sweet)	1	73 SSU
	0.99	140 SSU
	0.99	215 SSU
Egg Yolk	1.12	21,500 @ 35°F
Gelatin	1.01	1,380-2,580 SSU @ 160°F
Glucose	1.35 - 1.44	35M-100M SSU @ 100°F
		4M-11M @ 150°F
Honey	1.3	1250-1425 SSU @ 100°F
Ice Cream Mix	1.15	1050 SSU @ 46°F
Lard	0.96	287 SSU @ 100°F
Linseed Oil	0.92 - 0.94	143 SSU @ 100°F
		93 SSU @ 130°F
Malt Syrup	1.41	85,400 SSU @ 77°F
Maple Syrup	1.37	2,000 SSU @ 68°F

Margarine	0.93	13,900 SSU @ 84°F
Milk	1.02 - 1.05	31.5 SSU @ 68°F
Molasses		
A. First	1.4 - 1.46	1,300 - 23,500 SSU @ 100°F
		700 - 8,160 SSU @ 130°F
B. Second	1.43 - 1.48	6,536 - 61,180 SSU @ 100°F
		3058 - 15,294 SSU @ 130°F
C. Blackstrap	1.46 - 1.49	12,190 - 23,500 SSU @ 100°F
Mustard	1	17,000 SSU @ 85°F
Olive Oil	0.91 - 0.92	200 SSU @ 100°F
Peanut Butter	1.2	77,400 SSU @ 110-140°F
Sesame Seed Oil	0.92	184 SSU @ 100°F
		110 SSU @ 130°F
Soy Bean Oil	0.91	500 SSU @ 44°F
Tomato Paste	1.14	60M-80M SSU
		21M SSU Approx.
Water	1	31 SSU @ 68°F



Figure 4: Impeller View

Figure 5: Expanded View

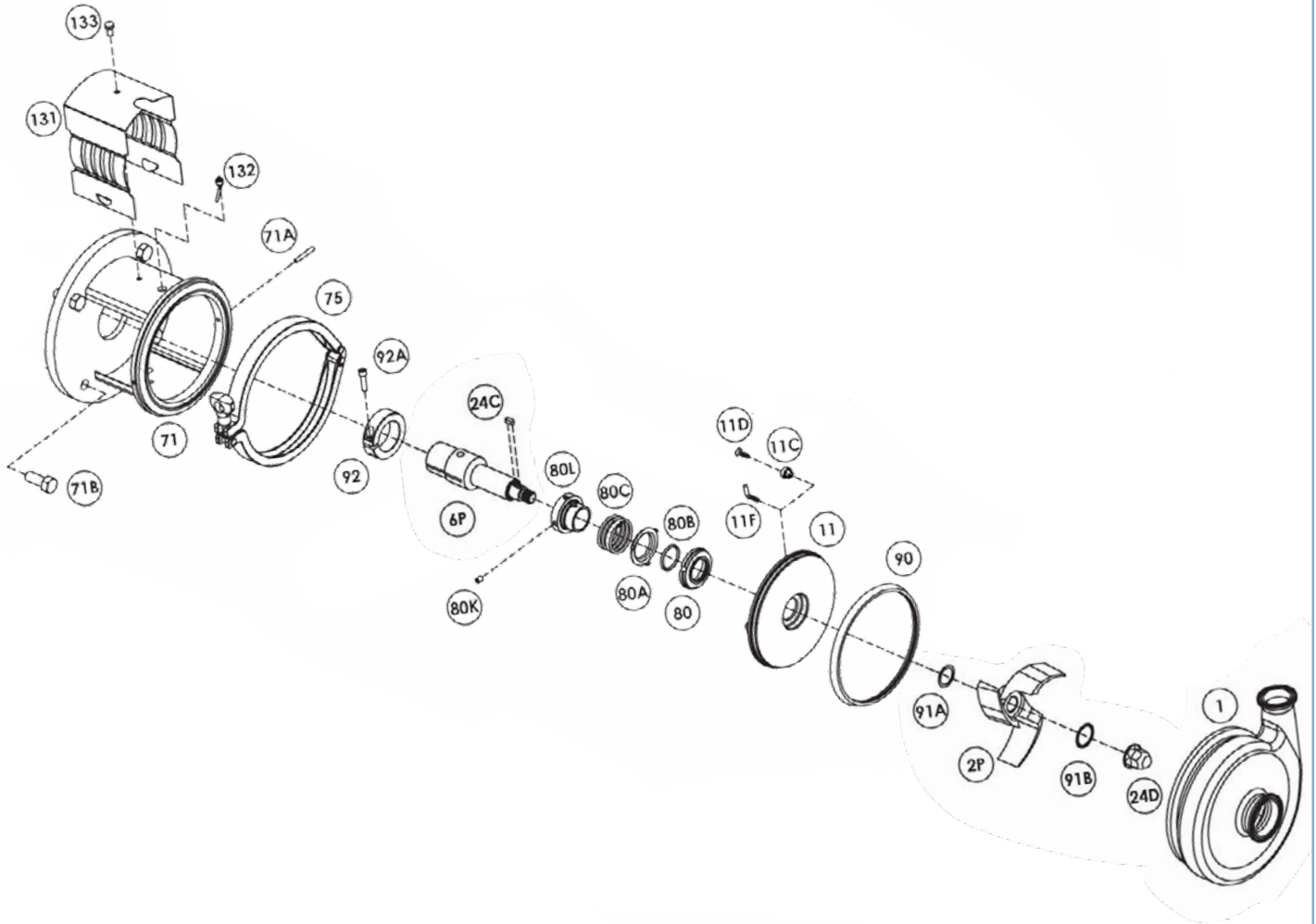

Part #	Part Name
1.	Casing
2P.	Impeller
6P.	Stub Shaft
11.	Backplate
11F.	Backplate Pin
24D.	Impeller Nut
91B.	Impeller Nut Gasket
91A.	Impeller Back Gasket
92.	Shaft Collar
24C.	Impeller Key
71.	Adaptor
71A.	Adaptor Pin

Part #	Part Name
71B.	Adapter Mounting Screws
75.	Tri-Clamp
80.	Carbon Seal
80A.	Cup
80B.	Seal O-ring
80C.	Spring
80K.	Set Screw Drive Collar
80L.	Drive Collar
90.	Casing Gasket
131.	Seal Guard Assembly