

FEATURES

- Fixed Frame Plate
- Upper Carrying Bar
- Lower Guiding Bar
- Support Column
- Movable Pressure Plate
- Clip-On EPDM Gaskets
- Tightening Bolts and Nuts
- Adjustable Feet

No. of plates	85
No. of effective plates	83
No. of passes	3
Plate pack dimensions A Measure	297 mm

CAUTION: DO NOT TIGHTEN BELOW MINIMUM DIMENSION

	Beer wort	Water
Mass flow rate	6813 Kg/h	8207 Kg/h
Inlet temperature	100°C (212°F)	12.7°C (54.9°F)
Outlet temperature	20°C (68°F)	75.5°C (167.9°F)
Pressure drop (Perm/Calc)	80.0/39.9 kPa	80.0/59.4 kPa
Velocity Connection (in/out)	0.945/0.930 m/s	1.16/1.19 m/s

Heat exchanged	598.5 kW
Heat transfer area	11.6 m ²
O.H.T.C clean conditions	4725 W/ (m ² +K)
O.H.T.C service	4236 W/ (m ² *K)
Fouling Resistance* 10000	0.0 m ² *K/W
Additional Excess Surface	10%
Mean Temperature	13.1 K

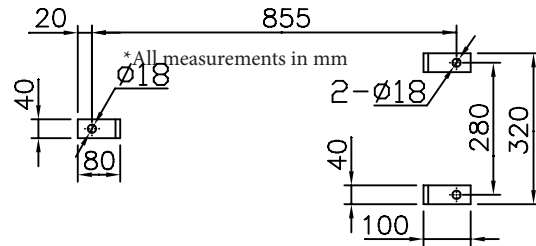
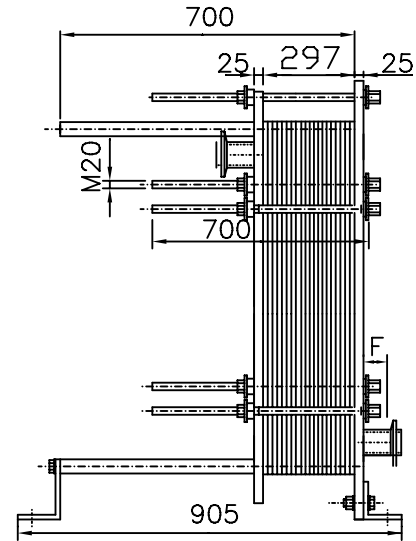

CONNECTION LOCATIONS

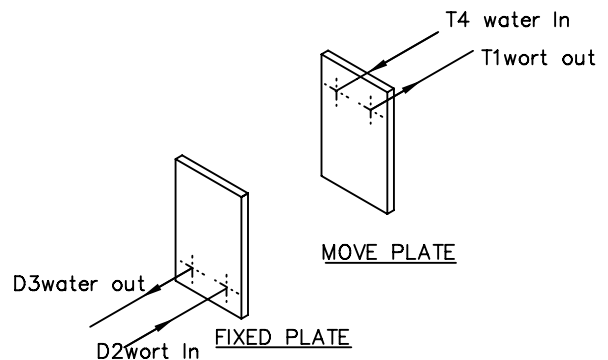

CONNECTION TYPES

