

## FEATURES

- Fixed Frame Plate
- Upper Carrying Bar
- Lower Guiding Bar
- Support Column
- Movable Pressure Plate
- Clip-On EPDM Gaskets
- Tightening Bolts and Nuts
- Adjustable Feet

No. of plates	25
No. of effective plates	23
No. of passes	3
Plate pack dimensions A Measure	87 mm

\*All measurements in mm

## CONNECTION LOCATIONS

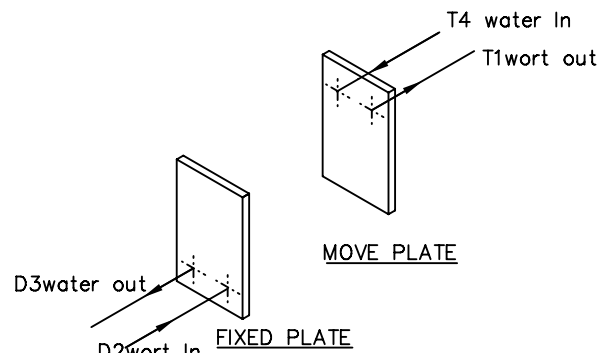

## CAUTION: DO NOT TIGHTEN BELOW MINIMUM DIMENSION

	Beer wort	Water
Mass flow rate	1136 Kg/h	1368 Kg/h
Inlet temperature	100°C (212°F)	12.7°C (54.9°F)
Outlet temperature	20°C (68°F)	75.5°C (167.9°F)
Pressure drop (Perm/Calc)	80.0/12.2 kPa	80.0/17.2 kPa
Velocity Connection (in/out)	0.158/0.155 m/s	0.194/0.199 m/s

Heat exchanged	99.74 kW
Heat transfer area	3.2 m <sup>2</sup>
O.H.T.C clean conditions	3257 W/ (m <sup>2</sup> +K)
O.H.T.C service	2708 W/ (m <sup>2</sup> *K)
Fouling Resistance* 10000	0.0 m <sup>2</sup> *K/W
Additional Excess Surface	10%
Mean Temperature	11.4 K

## CONNECTION TYPES

