

\*All measurements in mm

## FEATURES

- Fixed Frame Plate
- Upper Carrying Bar
- Lower Guiding Bar
- Support Column
- Movable Pressure Plate
- Clip-On EPDM Gaskets
- Tightening Bolts and Nuts
- Adjustable Feet

No. of plates	51
No. of effective plates	49
No. of passes	5
Plate pack dimensions A Measure	148 mm

## CAUTION: DO NOT TIGHTEN BELOW MINIMUM DIMENSION

	Beer wort	Water
Mass flow rate	1136 Kg/h	1368 Kg/h
Inlet temperature	100.0°C (212.0°F)	12.7°C (54.9°F)
Outlet temperature	20.0°C (68.0°F)	75.5°C (167.9°F)
Pressure drop (Perm/Calc)	80.0/51.6 kPa	80.0/73.9 kPa
Velocity Connection (in/out)	0.304/0.299 m/s	0.374/0.383 m/s

Heat exchanged	60.79 kW
Heat transfer area	1.6 m <sup>2</sup>
O.H.T.C clean conditions	4788 W/ (m <sup>2</sup> +K)
O.H.T.C service	4098 W/ (m <sup>2</sup> *K)
Fouling Resistance* 10000	0.0 m <sup>2</sup> *K/W
Additional Excess Surface	17%
Mean Temperature	12.9 K

## CONNECTION TYPES

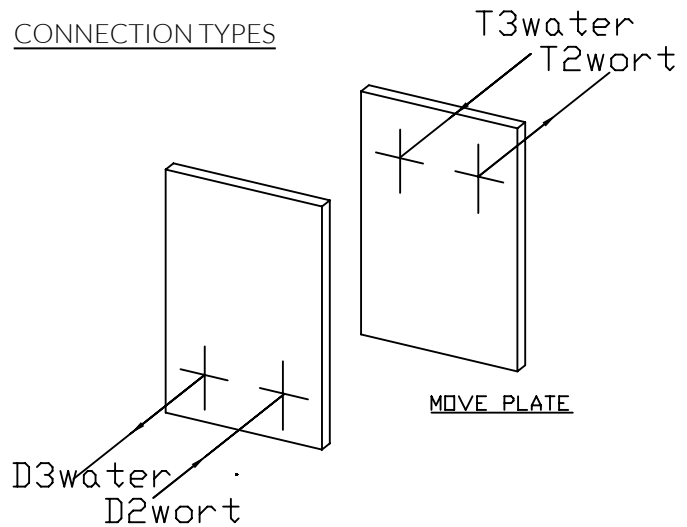

## CONNECTION TYPES

