



CPE C114 MD CENTRIFUGAL PUMP (1 HP-3 HP)

FOR CRAFT FOOD AND BEVERAGE INDUSTRIES

PUMPS

-

HOSES

-

HEAT EXCHANGERS

-

FLOW METERS

-

GASKETS

-

VALVES

-

FITTINGS

-

THERMOMETERS

-

PORTABLE SYSTEMS

-

AND MORE

w

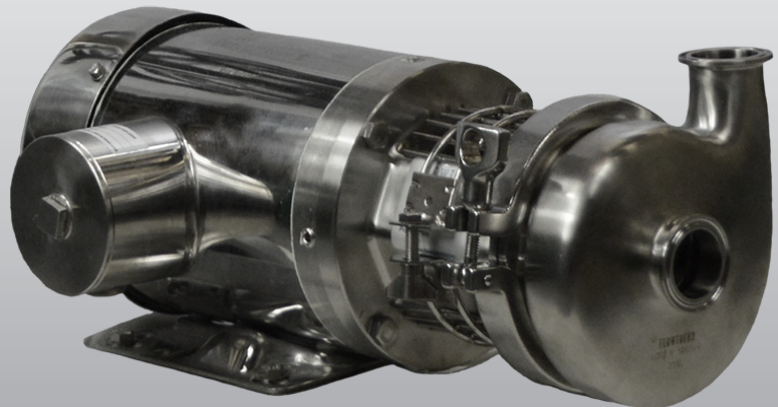

Technical Specifications



Materials

Parts in contact w/ product:	Stainless steel AISI 316L
Other steel parts:	Stainless steel AISI 304
Gaskets in contact w/ product:	EPDM

Mechanical seal

Rotary Seal:	Carbon or Silicon carbide (SiC)
Stationary Seal:	SS, SiC or Ceramic,
Gaskets	EPDM
Surface finish:	Bright polish
Motor:	S.S Premium Efficiency Nema C Face

Operating limits

Nominal pressure:	10 bar 145 PSI
Temperature range:	14 °F to 248 °F 284 °F (SIP, max. 30 min.)

Maximum flow:	100 m ³ /h 150US GPM
Maximum differential head:	21 m 75 ft
Maximum speed:	3500 rpm

C-series (Close Coupled) Centrifugal Pumps are the most common pumps used in Craft Breweries. Our C-Series is made in North America, 3A approved and provides high capacity at a low price. They feature heavy duty stainless steel construction with a stainless steel washdown motor that make cleaning easier and if well maintained, will last a lifetime. These pumps will give you years of excellent service and when needed, replacement parts are interchangeable with most major brands of sanitary C-series pumps.



HorsePower	Flow Rate	Head
1 HP	75 GPM	65 ft.
1 1/2 HP	100 GPM	75ft.
2 HP	125 GPM	75 ft.
3 HP	150 GPM	75 ft.

Centrifugal Pump

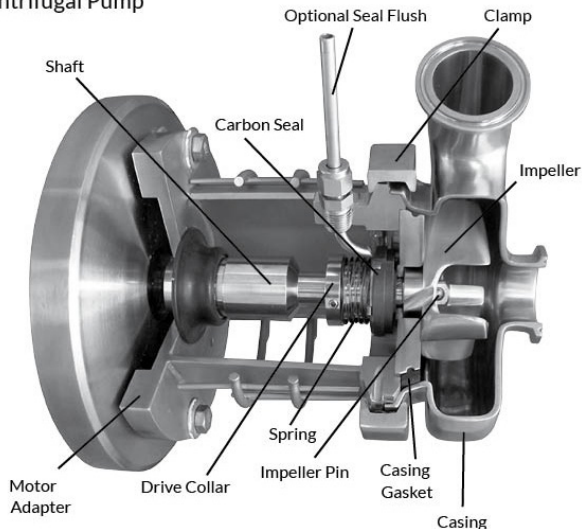

Port Connection

Come standard with M Tri-Clamp style connections, but we can provide any connection style possible. Including Acme Bevel Seat Thread, NPT, Flanged or Weld.

Model	Inlet Opt.	Outlet Opt.	Max Impeller
C100	1 1/2"	1"	3.68"
C114	1 1/2" - 2"	1 1/2"	4"
C216	2"	1 1/2"	6"
C218	2" - 3"	1 1/2"	8"
C328	3" - 4"	2"	8"



Pump Capacity Curves



Size: 114 1.5x1.5
Speed: 3600 rpm
Dia: 4 in

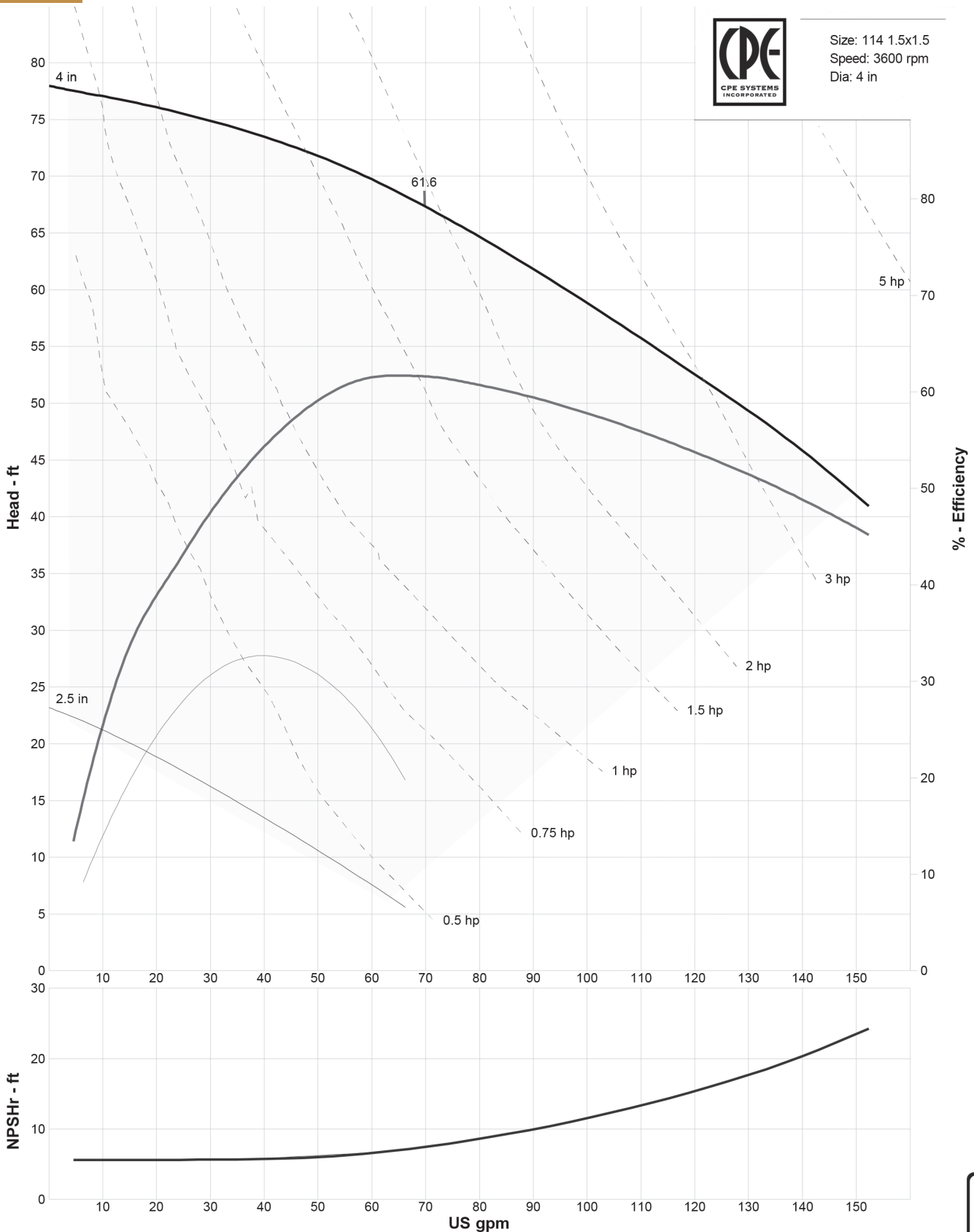

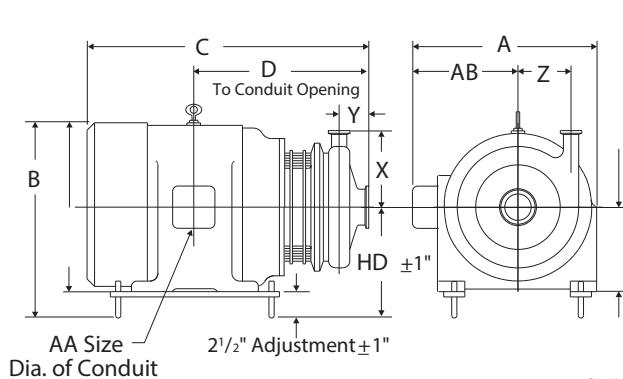

D Dimension (Face of inlet to center of conduit opening)

180 to 360 Frame Motors

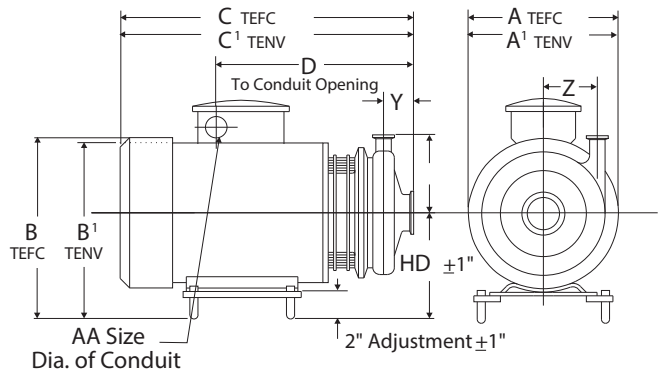

56 to 140 Frame Motors

Pump and Motor Dimensions with "Easy-Clean" Totally Enclosed Motors

Pump Model	Frame	A	A ¹	B	B ¹	C*	C ^{1*}	C**	C ^{1**}	D*	D**	HD	AA	AB
C114	FF56C	7 ^{9/32}	6 ^{1/2}	9 ^{1/8}	8 ^{3/4}	21 ^{1/4}	20 ^{9/16}	21 ^{1/2}	20 ^{13/16}	17 ^{3/16}	17 ^{7/16}	5 ^{1/2}	1 ^{1/2}	—
	184TC	11 ^{7/8}		11 ^{11/16}		21 ^{1/8}		21 ^{3/8}		13 ^{13/16}	14 ^{1/16}	7	3/4	7 ^{3/16}
C216	FF56C	7 ^{9/32}	6 ^{1/2}	9 ^{1/8}	8 ^{3/4}	21 ^{3/8}	20 ^{3/4}	21 ^{5/8}	21	17 ^{5/16}	17 ^{9/16}	5 ^{1/2}	1 ^{1/2}	—
	184TC	11 ^{7/8}		11 ^{11/16}		21 ^{7/8}		21 ^{1/8}		14 ^{9/16}	14 ^{13/16}	7	3/4	7 ^{3/16}
	215TC	14 ^{1/2}		13 ^{3/16}		25 ^{9/16}		25 ^{13/16}		16 ^{11/16}	16 ^{15/16}	7 ^{3/4}	1	9 ^{1/16}
	256TC	16 ^{7/16}		15 ^{1/4}		29 ^{15/16}		30 ^{3/16}		18 ^{11/16}	18 ^{15/16}	8 ^{3/4}	1 ^{1/4}	10
C218	FF140TC	7 ^{9/32}	6 ^{1/2}	9 ^{1/8}	8 ^{3/4}	22	21	22 ^{1/4}	21 ^{1/4}	17 ^{19/32}	17 ^{27/32}	5 ^{1/2}	1 ^{1/2}	—
	184TC	11 ^{7/8}		11 ^{11/16}		22 ^{1/4}		22 ^{1/2}		14 ^{15/16}	15 ^{3/16}	7	3/4	7 ^{3/16}
	215TC	14 ^{1/2}		13 ^{3/16}		25 ^{13/16}		26 ^{1/16}		16 ^{15/16}	17 ^{3/16}	7 ^{3/4}	1	9 ^{1/16}
	256TC	16 ^{7/16}		15 ^{1/4}		31 ^{1/16}		31 ^{5/16}		19 ^{13/16}	20 ^{1/16}	8 ^{3/4}	1 ^{1/4}	10
	284TC	19 ^{5/16}		16 ^{3/4}		32		32 ^{1/4}		20 ^{3/16}	20 ^{7/16}	9 ^{1/2}	1 ^{1/2}	12 ^{1/16}
C328	FF140TC	7 ^{9/32}	6 ^{1/2}	9 ^{1/8}	8 ^{3/4}	22 ^{5/8}	21 ^{5/8}	23 ^{1/8}	22 ^{1/8}	18 ^{7/32}	18 ^{23/32}	5 ^{1/2}	1 ^{1/2}	—
	184TC	11 ^{7/8}		11 ^{11/16}		22 ^{3/4}		23 ^{1/4}		15 ^{7/16}	15 ^{15/16}	7	3/4	7 ^{3/16}
	215TC	14 ^{1/2}		13 ^{3/16}		26 ^{5/16}		26 ^{13/16}		17 ^{7/16}	17 ^{15/16}	7 ^{3/4}	1	9 ^{1/16}
	256TC	16 ^{7/16}		15 ^{1/4}		31 ^{11/16}		32 ^{3/16}		20 ^{7/16}	20 ^{15/16}	8 ^{3/4}	1 ^{1/4}	10
	284TC	19 ^{5/16}		16 ^{3/4}		32 ^{5/8}		33 ^{1/8}		20 ^{13/16}	21 ^{5/16}	9 ^{1/2}	1 ^{1/2}	12 ^{1/16}
	286TC	19 ^{5/16}		16 ^{3/4}		34 ^{3/8}		34 ^{7/8}		21 ^{13/16}	22 ^{5/16}	9 ^{1/2}	1 ^{1/2}	12 ^{1/16}

* With Tri-Clamp connections.

** With threaded bevel seat connections.

Dimensions are approximate and for guidance only. On application where exact dimensions are required, request a certified print from Tri-Clover.

NOTES: 1—Dimensions for single phase #140 frame motors longer.

--These dimensions are for pumps using standard "C" Flange Motors.

--Tri-Flo C Series pumps will not accept TSC Frame Motors.



Viscosity and Specific Gravity Table

Product	Specific Gravity	Viscosity
Acetic Acid		
5%	1.01	
10%	1.01	31.7 SSU @ 59°F
50%	1.06	33 SSU @ 59°F
80%	1.08	35 SSU @ 59°F
Animal Fat	0.9	130 SSU @ 115°F 50 SSU @ 200°F
Barbecue Sauce	1.05	11,500 SSU @ 40-75°F
Beer	1.02	32 SSU @ 68°F
Blood - Animal	.93-.98	15,000 SSU @ 55°F
Butter	.93-.98	15,000 SSU @ 55°F 440 SSU @ 90°F 220 SSU @ 115°F
Coconut Oil	0.92	125 SSU @ 106°F
Corn Oil	0.92	135 SSU @ 130°F 54 SSU @ 212°F
Corn Starch Solutions		
22 Baume	1.18	150 SSU @ 70°F 130 SSU @ 100°F
24 Baume	1.2	600 SSU @ 70°F 440 SSU @ 100°F
25 Baume	1.21	1400 SSU @ 70°F 800 SSU @ 100°F
Cottage Cheese	1.02	4,300 SSU
Dressing		
Cream (Sweet)	1	73 SSU
	.99	140 SSU
	.99	215 SSU
Egg Yolk	1.12	21,500 @ 35°F
Gelatin	1.01	1,380 - 2,580 SSU @ 160°F
Glucose	1.35 - 1.44	35M - 100M SSU @ 100°F 4M - 11M @ 150°F

Product	Specific Gravity	Viscosity
Honey	1.3	1250 - 1425 SSU @ 100°F
Ice Cream Mix	1.15	1050 SSU @ 46°F
Lard	0.96	287 @ 100°F
Linseed Oil	.92-.94	143 @ 100°F 93 @ 130°F
Malt Syrup	1.41	85,400 SSU @ 77°F
Maple Syrup	1.37	2,000 SSU @ 68°F
Margarine	0.93	13,900 SSU @ 84°F
Milk	1.02 - 1.05	31.5 @ 68°F
Molasses		
A. First	1.4 - 1.46	1300 - 23,500 SSU @ 100°F 700 - 8160 SSU @ 130°F
B. Second	1.43 - 1.48	6535 - 61,180 SSU @ 100°F 3058 - 15294 SSU @ 130°F
C. Blackstrap	1.46 - 1.49	12,190 - 255M @ 100°F
Mustard	1	17,000 SSU @ 85°F
Olive Oil	.91 - .92	200 SSU @ 100°F
Peanut Butter	1.2	77,400 SSU @ 110 - 140°F
Sesame Seed Oil	0.92	184 SSU @ 100°F 110 @ 130°F
Soy Bean Oil	0.91	500 SSU @ 44°F
Tomato Paste	1.14	60M - 80 M SSU 21M SSU approx.
Water	1	31 SSU @ 68°F