

BENCHMARK MEDIA SYSTEMS, INC.

PPM-1 Meter Card Instruction Manual

1.0 The PPM.....	1
1.1 The PPM-1	1
2.1 Measurement Conventions.....	1
2.2 System References	2
3.0 Connections to the PPM-1 Card.....	2
3.1 Audio Input Connections	2
3.2 Power Supply Considerations	3
3.2.1 Power Supply Connections	3
3.3 Peak LED Connection.....	3
3.4 Peak Hold Switch Connection.....	3
4.0 Calibration Adjustment	4
4.1 Test Equipment	4
4.2 Meter Calibration	5
4.3 Peak LED Calibration	5
5.0 Modifications	5
5.1 Time Constants.....	5
5.2 Pre-Emphasis Networks	6
6.0 Further Reading.....	7
7.0 Schematic	9
8.0 Component Layout.....	11
9.0 Expanded Component Layout.....	13
10.0 Dual Meter Cable Assembly	15

1.0 The PPM

The PPM shows peaks of program material and thus relates to system overload better than the VU meter. The peak program meter has its roots in Europe and began life in the mid 1930s. The PPM has essentially two differing standards. There are the EBU, BBC, CBC standard, and the IEC, DIN standard. These two standards have two differing sets of time constants. Beyond the time constants, the various implementations of these standards usually have differing meter scales.

All PPMs have the following elements in common: They have an input amplifier and often a low pass filter. They have a full wave rectifier, a peak detector, and logarithmic amplifier to drive the meter movement. The total meter range is usually close to ≈ 28 dB.

1.1 The PPM-1

The Benchmark PPM-1 has been set to work with the CBC, BBC, and EBU set of time constants. These time constants are a 10 mSec integration time and a 2.8 second fallback time from 2.8 seconds from a 0 reading to a -22 meter reading. The PPM-1 is normally used with a custom Sifam meter that includes a “beyond scale” peak responding LED, and a precisely linear meter scale. Otherwise the scale would be known as the ABC “West Coast” scale.

We have chosen the Sifam PPM meter as the meter movement of choice, because of its exceptional high quality. As mentioned, the PPM scale calibration is a modification of the ABC West Coast scale. The modification involves the change from the BBC cardinal spacing to that of a linear (versus current) spacing. This modification has been done so that the calibration will conform to the output of the linear log amplifier located on the PPM-1 meter card.

1.2 Measurement Conventions

Since all available audio level meters are voltage-measuring devices, and if the system that receives these units is a “600 Ω ” power matched system, then, for the measurements to have accuracy in terms of power measurement, proper transmission line rules *must* be followed. That is to say, all lines must be terminated in their correct load impedance for the indicated power levels to be correct. Far more preferable, however, is the conversion of equipment, wherever possible, to the voltage sourced interconnect system. See the Benchmark Media Systems application note, “A Clean Audio Installation Guide”.

The development of the voltage sourced audio interconnect system, was brought about by the easily available, low output impedance amplifier and the recognition that the 600 Ω power matched system, while good for telephone interconnect, is far from optimum for high quality audio transmission. And since the term dBm is a dB ratio referenced to one milliwatt, an absolute power level with *any* line impedance, it is *not* applicable to the voltage amplitudes being measured. Hence, a new voltage reference designator is needed, rather than the power designator. The professional audio world is familiar with the relative voltage amplitudes that exist in the 600 Ω power matched systems, and many existing VU meters relate to those amplitudes. Hence the dBu designator is now used, using the *same* voltage found a 600 Ω power matched system, where 0 dBu is equal to 0.7746 volts RMS.

!!! Warning !!!

The term dBu has no impedance or power references, and therefore may not be the most appropriate way to describe levels in sound reinforcement systems. However, in most broadcast, sound recording and other systems where input to output power gain calculations are not needed, it is ideal.

The term dBu is found in the European Nordic N-10 standard, and is in use throughout most of Europe and the United States as well, even though there is no U.S. standard. We will use the term dBu in all of our discussions. Occasionally you may see the term dBv used in older literature from Benchmark Media Systems; this has the same meaning as dBu. Other authors may use the term dB/.7 or dB/0.775 to indicate the same voltage reference.

1.2 System References

The PPM-1 uses a system reference line up tone of +8 dBu for system setup, this corresponds to the -8 reading on the meter face. Peak calibration is thus referenced to +16 dBu, since there is an average difference of 8 dB between actual program material peaks and the average of tone line up. This calibration scheme allows both PPM meter systems and VU meter systems to be used on the same program material, normally with a good correspondence.

2.0 Connections to the PPM-1 Card

Three things must be interfaced to make the PPM-1 operational, these are; 1) audio signal input, 2) power supply connections, and 3) peak hold switch, if desired. Additionally, if two meters are used together as say, a “stereo pair”, and is desired to run the internal lamps in series, lamp power interconnection between the two meter-boards is necessary.

2.1 Audio Input Connections

Balanced audio input to the meter card is provided through a 0.025" square, 3-pin header post and mating three pin female connector, J1101. This jack is located at the top left-hand corner of the circuit board. You will notice that a loop through set of posts has been provided in the case where a phase meter is desired along with two PPM-1 meter systems. Construct the input connector such that the shield (drain) is in the center position of the three-pin housing, and the two signal wires are on the outer pins of the connector. The inverting input is the top most pin of the jack while the non inverting input is the bottom pin.

The PPM-1 has a bridging differential input with a differential impedance of 100 k Ω . It has a single ended input impedance of 49.9 k Ω when operated into the inverting input (pin 3) and a 74.8 k Ω impedance when operated into the non-inverting input (pin 1). If you feed the card from an unbalanced source, and use the non-inverting input, *be sure* to ground the inverting input; otherwise the gain of the input amplifier will not be correct and the meter calibration will be 6 dB low. The advantages of the bridging differential input are: 1) Freedom from loading effects and the resultant amplitude changes across a program line, 2) Isolation of the meter from the program line, 3) The ability to eliminate ground loops and other induced interference, 4) Direct and easy interface to balanced outputs.

We strongly recommend that the advantage of the balanced input also be used when connecting to an unbalanced signal source. The technique needed is known as forward referencing and is accomplished by first making sure that all signal references (grounds) are tied together through the use of external insulated ground wires. The drain wire of the shielded pair bringing the audio signal into the meter board should not be used for this purpose. These ground wires should be connected in a “star” configuration.

The signal output is connected to the non-inverting input of the meter and then the inverting input is tied to ground at the signal *output* port. The shield (drain) wire is then tied to ground at only *one* end. See “A Clean Audio Installation Guide” for a much more detailed explanation.

2.2 Power Supply Considerations

The PPM-1 meter amplifier requires regulated ± 15 to ± 18 volt @ 25 mA min. bipolar supplies for the analog circuitry. If a PS-1 has been purchased with the meter system, the meters have been calibrated with this supply. It is important to keep the power supply that was used for calibration with the associated meters. This is because both the peak LED and the log amplifier are referenced to the positive power supply. The lamps are normally powered from this supply as well. They are fed a reduced voltage to lower intensity for long life. The power rating of the PS-1, ± 18 volts @ 200 mA, is sufficient to power a system of two meter circuits as well as the internal lamps.

2.2.1 Power Supply Connections

The power supply is connected to the PPM-1 board at J2101. The order of the input connections is +, ground, and -. The + input is at the top of the vertical arrangement.

A power loop through is provided so that a second or third meter may be operated from the same power supply. Be careful not to invert the power connections and cause a reverse polarity on the card. If using a PS-1 supply, this may permanently damage the PS-1, but will in all likelihood not damage the meter board.

2.3 Peak LED Connection

The peak LED is connected to the board via two 0.025" square posts that are located just to the left of the meter terminal, J1102. The brown wire should be connected to the top pin, and the red wire to the bottom pin. This LED is intended to mount in the face of the Benchmark Peak Program Meter. If this card is being used with a meter other than that supplied by Benchmark, an external mounting hole will need to be made in the equipment. Under no circumstances should the user attempt to drill a hole in the face of a meter. Plastic particles or phenolic dust will find its way into the meter movement, rendering it useless.

2.4 Peak Hold Switch Connection

Two header posts exist in the upper right hand corner of the PCB that allow the actuation of a peak hold function. The peak hold function may be desirable to allow the viewing of the highest peak in a particular production piece.

A simple contact closure between the two posts is all that is necessary to actuate the peak hold function. Peak release is returned the moment the contact closure is removed. This is easily implemented for two meters at once using a double pole single throw switch, such as the Schadow F series pushbutton switch.

3.0 Calibration Adjustment

3.1 Test Equipment

The meters and cards were calibrated at the factory, and should not need calibration if they were purchased with a PS-1. However if a different, customer provided power supply is to be used the meters will need minor calibration adjustment.

If only one or two meters are being calibrated, the precision adjustment of level at the output of a audio generator for each calibration point may be made while monitoring the levels using a precision DVM such as the Fluke 8050A or equivalent. Even with just one or two meters, due to the iterations that are necessary between the calibration points, an attenuator arrangement is desirable. If, however, many meters are to be calibrated, then a precision attenuator setup is necessary for the rapid changes of precision levels needed for meter calibration.

We suggest calibration is best accomplished using the following pieces of test equipment:

- 1) A function generator is preferable, due to its inherent amplitude stability,
- 2) A precision 600 ohm step attenuator set with one 10 dB/step attenuator and one 1 dB/step attenuator (typical total range is 110 dB), such as those manufactured by Tech-Labs and Hewlett-Packard,
- 3) A precision digital AC voltmeter, and our preference is the Fluke 8050A.

Make sure that the output impedance of the function generator has been increased to 600 Ω . Most function generators have an output impedance of 50 ohms. Therefore, additional (external) build out resistance of 550 ohms is necessary to give it a precise 600- Ω -output impedance. Likewise, a precision 600- Ω termination must be used at the output of the attenuator. This is necessary for the amplitudes from the attenuator set to have accuracy, eliminating continual slight readjustment of the audio generator output level. It is often necessary to use some gain make up after the attenuator is set to achieve the maximum output level that is needed. This is most easily done with a simple line amplifier. Make sure the line amplifier has a high, $\approx 20 \text{ k}\Omega$ or greater, input impedance and a low, $\approx 60 \Omega$, output impedance.

Set the attenuator for 0 dB of attenuation and then adjust the output level to the maximum output necessary for calibrating the peak LED. Normally this would be +24 dBu. Make sure the generator is set for operation at 1 kHz, and that none of the amplifiers are clipping. Use the digital voltmeter in parallel with the PPM-1 input (and at its lowest scale without over-ranging) to measure the level at the input of the PPM-1. The Fluke meter is capable of direct dBu (dBm-600 Ω) readings and may be used in that mode to avoid constant translation from dBu to volts. However, the following chart will aid in relating the levels to AC voltage, if that is necessary.

Once the attenuator system is operational, it will facilitate the rapid change in output levels that are necessary for the meter calibration.

Meter Scale	dB/0.7746	1 kHz A.C. Voltage
Peak LED	+24	12.277 volts
Full CW Cardinal	+22	9.752 volts
+4	+20	7.746 volts
0	+16	4.887 volts
-4	+12	3.084 volts
-8	+ 8	1.946 volts
-12	+ 4	1.228 volts
-16	+ 0	0.775 volts
-20	-4	0.489 volts
Full CCW Cardinal	-6	0.339 volts

Fig 3.1-Meter Calibration Chart

3.2 Meter Calibration

The trim potentiometer in the center of the PCB, labeled either “Full scale Cal” or “Full scale +4 Cal” is the calibration potentiometer used to set the +4 meter point with an incoming tone signal level of +20 dBu. The trim potentiometer incorrectly labeled “-4 Cal”, or correctly labeled “-8 Cal” adjusts the meter when being fed a +8 dBu tone input signal. It is important to leave the offset trim adjustment in the center of its range, as this will be used only for minor trimming once the basic calibration has been accomplished. Approximately four iterations between the “Full Scale +4 Cal” pot and the “-8 Cal” pot will bring the meter to an accurate calibration. Once these two calibration points have been set, it is well to check the other cardinals on the meter for conformance points to the accepted tolerances of the system. The Offset Trim potentiometer is used to make any minor adjustments to the -20 calibration once the +4 and -8 calibrations have been accomplished. If changes in the offset trim are made then it is important to go back and further check the accuracy of the +4 and -8 trims.

3.3 Peak LED Calibration

The “LED Cal” potentiometer sets the level at which the beyond scale peak LED will illuminate. Since the meter itself will read to +22 dBu, we suggest +24 dBu as a trip level since it is still 3 dB below the clip point of most modern audio equipment. Adjust the potentiometer until the LED just begins to blink. With tone input this cal point is very sensitive, and thus will provide an accurate setting for the peak indicator. The calibration range of this circuit is $\approx +17.5$ to $\approx +26.0$ dBu. This adjustment is independent of other calibration settings.

This completes the calibration of the meter.

4.0 Modifications

The following modifications may be made to the PPM-1 meter driver card.

4.1 Time Constants

Changes may be made in a number of areas to the PPM-1 according to the needs of the user. The first area that may be desirable is a change in the time constants involved in the peak mode. By studying the schematic, it will become obvious that the drive transistor that feeds the charge capacitor is not necessary with the 16.2K ohm resistor in place. It is included for those who wish to lower the attack time constant for faster response over the CBC/BBC determined constant. It would be well to not go lower than 50 ohms thus limiting the demand on the drive transistor and preventing overshoot in the peak detector.

4.2 Pre-Emphasis Networks

It is a simple matter to turn the PPM-1 into a quasi deviation meter to monitor an FM STL. By replacing the second stage of the input buffers with a set of components, the required pre-emphasis is obtained. The following chart gives the recommended values for various time constants. As an additional possibility, an complete bank of pre-emphasis networks may be mounted on a switch along side of the PPM-1 and the user may then have his choice of time constants. The diagram for the modified second stage is given below in Figure 5.3.

The operation of the pre-emphasis network is as follows. The four components shown in figure 5.3 create the curve shown in figure 5.2. The first break point of the curve is set by components R1 and C1. The frequencies at which the 3 dB points come into play are defined by:

$$F = \frac{1}{2\pi RC}$$

The upward slope is created by the fact that as frequency increases the X_C of C1 is constantly dropping and the gain of the circuit increases directly with C1 and R1 setting the gain. f_2 is set by C1 and R2. At f_2 the X_C of C1 is equal to the resistance of R2 which is the gain limiting resistor and the curve begins to flatten. The maximum gain is set by R1 and R2, as defined by:

$$A_{\max} \text{ (in dB)} = 20 \text{ Log } \frac{R1+R2}{R2}$$

The third time constant f_3 is set by C2 and R1 and is intended to limit the high frequency noise of the amplifier stage.

Time C	f_1	R1	C1	R2	C2	MAX A	f_2	f_3
25 μ sec	6.37 kHz	11.5 k Ω	0.0022 μ F	1.82 k Ω	220 pF	17.5 dB	39.7 kHz	62.9 kHz
50 μ sec	3.18 kHz	22.6 k Ω	0.0022 μ F	1.82 k Ω	100 pF	22.6 dB	39.7 kHz	70.4 kHz
70 μ sec	2.27 kHz	31.6 k Ω	0.0022 μ F	1.82 k Ω	68 pF	25.3 dB	39.7 kHz	74.1 kHz
75 μ sec	2.12 kHz	34.0 k Ω	0.0022 μ F	1.82 k Ω	68 pF	25.9 dB	39.7 kHz	68.8 kHz
90 μ sec	1.77 kHz	41.2 k Ω	0.0022 μ F	1.82 k Ω	56 pF	27.5 dB	39.7 kHz	69.0 kHz
120 μ sec	1.33 kHz	54.9 k Ω	0.0022 μ F	1.82 k Ω	47 pF	29.9 dB	39.7 kHz	61.7 kHz

Figure 4.1 Time Constant Component Values

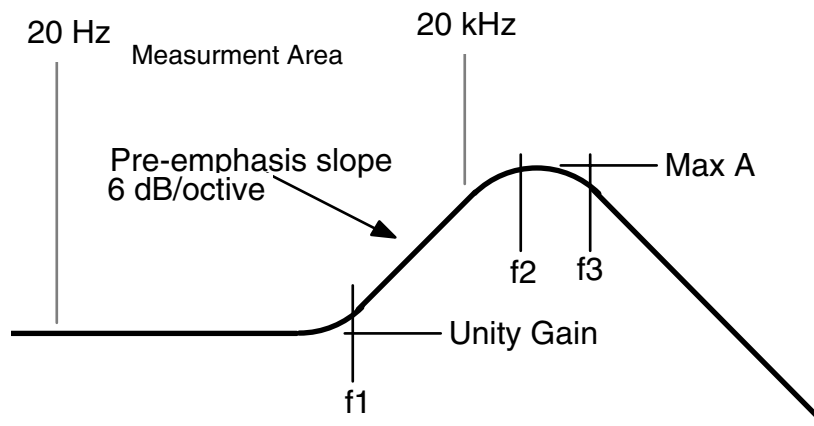

Figure 4.2 Pre-emphasis Curve

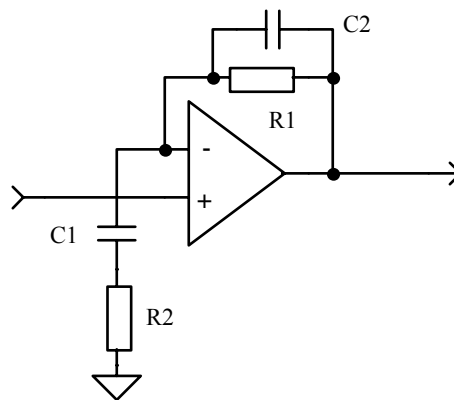

Figure 4.3 2nd Stage Pre-emphasis Circuit

5.0 Further Reading

A paper by the late Hans Schmid, entitled “The Peak Program Meter and the VU Meter in Broadcasting”¹ is an excellent source of information concerning the advantages of peak program meters. This paper was presented at the 67th convention of the Audio Engineering Society in New York, 1980, preprint #1691 (I-8). Preprints may be obtained by contacting,

Audio Engineering Society
 60 East 42nd Street
 New York, NY 10165-0075
 (212) 661-8528

Benchmark Media Systems Inc.
 5925 Court Street Road
 Syracuse, NY 13206-1707
 (315) 437-6300, FAX 437-8119