

**IFA-4  
INSTRUCTION MANUAL**

***BENCHMARK MEDIA SYSTEMS, INC.  
5925 Court Street Road  
Syracuse, New York 13206-1707  
(315) 437-6300 FAX (315) 437-8119***

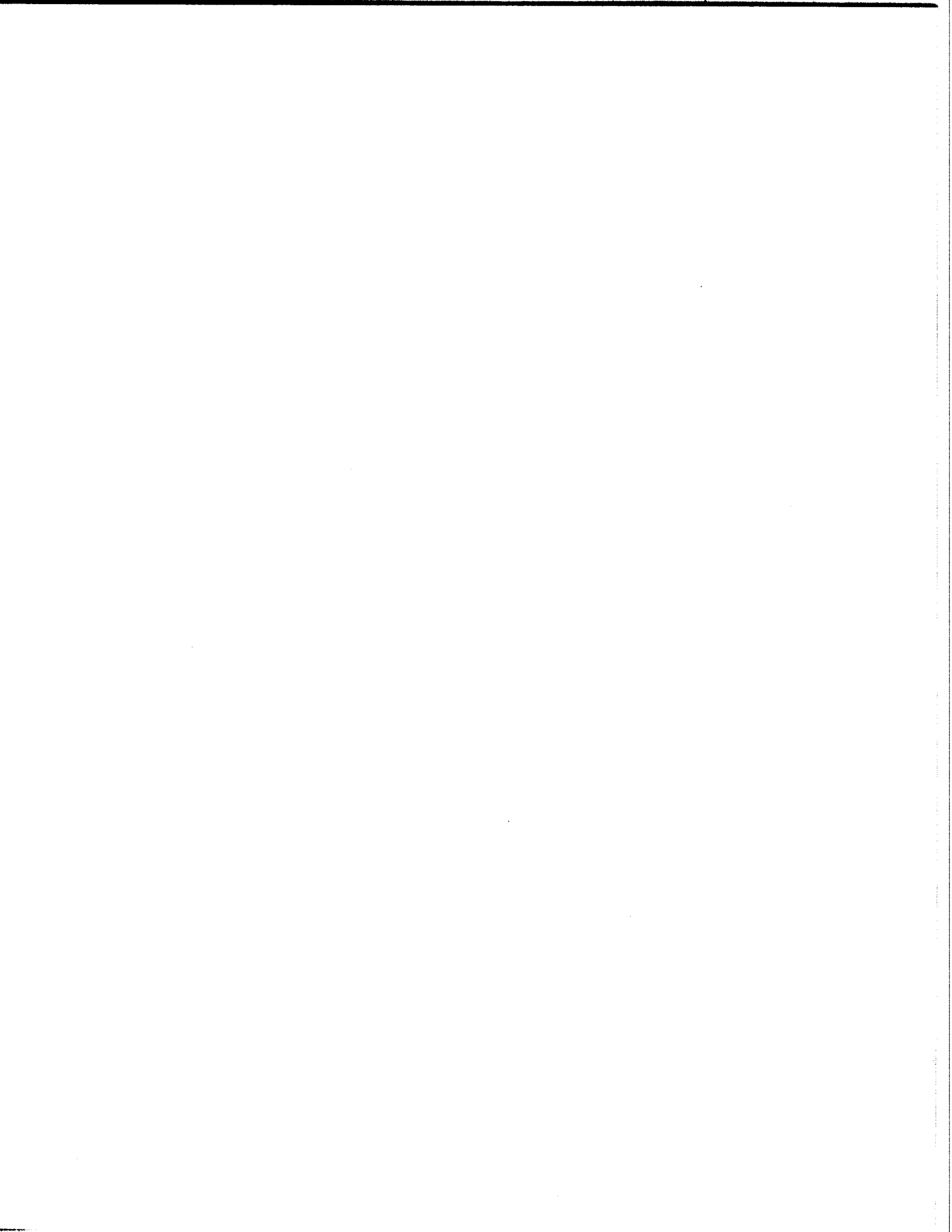

# BENCHMARK MEDIA SYSTEMS, INC.

## DIA-1 and 2 Instruction Manual

### Table of Contents

1.0 Introduction .....	1
2.0 General Features .....	1
2.1 Gain Structures.....	1
3.0 Unpacking and Installation .....	1
3.1 Physical Installation.....	2
3.2 Electrical Installation.....	2
3.2.1 Power Connections .....	3
3.2.2 Input and Output Connections .....	4
3.2.2.1 Equipment Interconnection .....	5
3.2.3 Output Impedance.....	6
3.2.4 Trim Adjustments.....	6
3.2.4.1 DC Offset Adjustment.....	6
3.2.4.2 Common Mode Rejection Adjustment.....	7
4.0 Troubleshooting and Repair .....	8
4.1 Soldering Technique .....	8
5.0 Component Assembly.....	10
6.0 Electrical Schematic .....	11

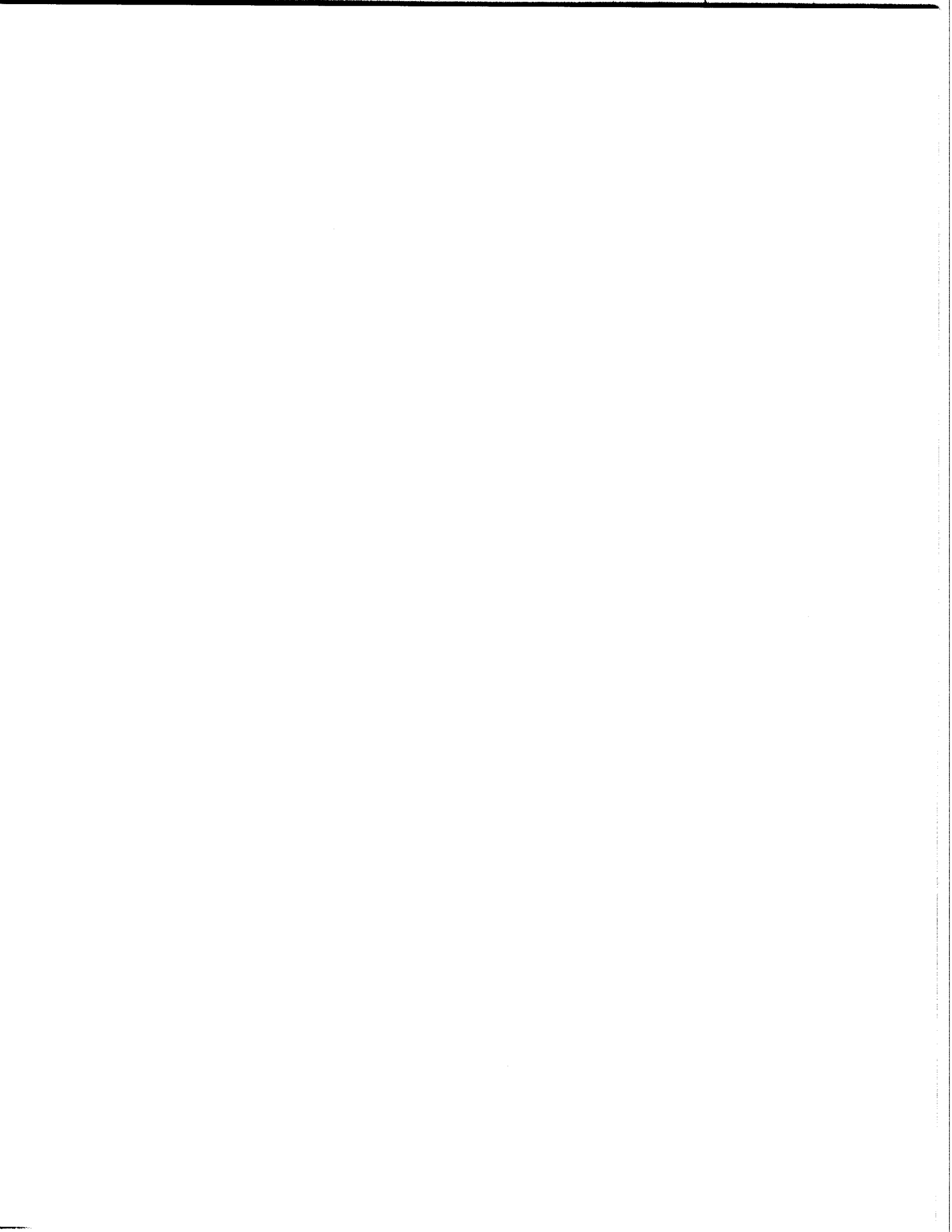

REVISIONS

A SEE DCN NO. 57

5/17/89

QRP

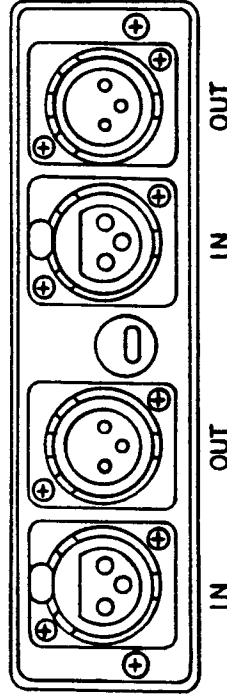
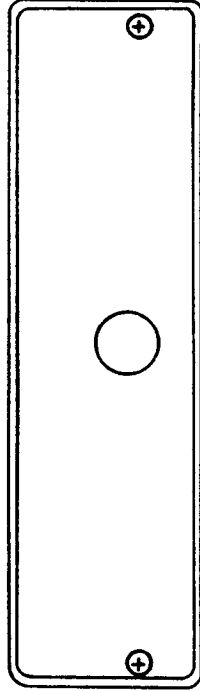
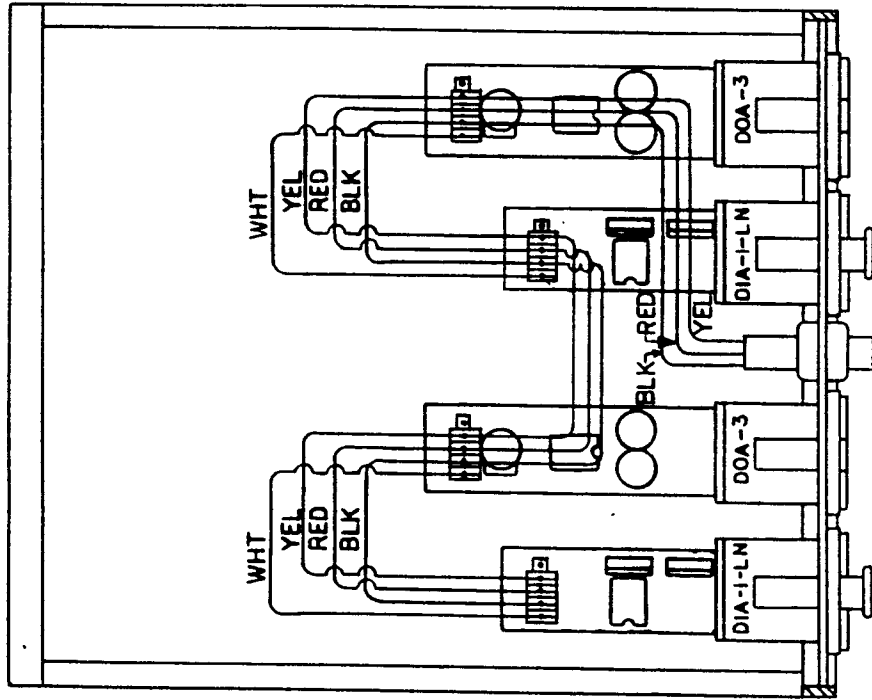

NOTES:  
1. POWER CORD MAY PASS THROUGH EITHER  
END PLATE.

Benchmark Media Systems

IFA-4

SCALE	CHECKED BY	DRAWN BY	PENFIELD
DATE	4/29/88	<i>H. St. Ludick</i>	
SIZE	A WIRING DIAGRAM		
	DRAWING NO. 350018		

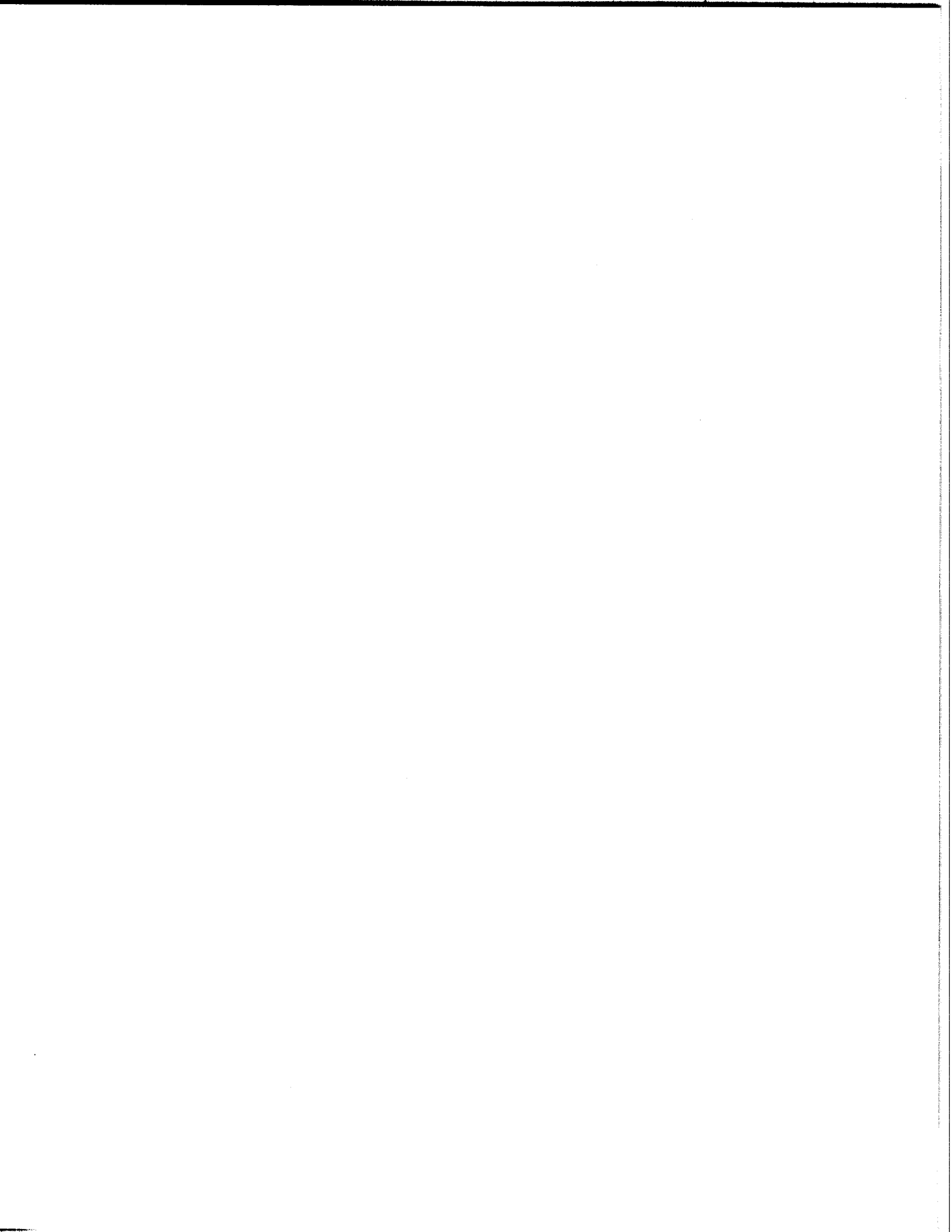

## 1.0 Introduction

The standard DIA-1 & 2 and the Low Noise DIA-1-LN & 2-LN Differential Input Amplifiers are universal input devices designed to provide both a balanced input and the gain reduction necessary to interface consumer and semi-professional audio equipment to the professional environment.

## 2.0 General Features

The DIA-1&2 balanced input devices have fixed gain that must be selected at the time of order, an input impedance of 100 k  $\Omega$  with the standard series and 10 k $\Omega$  with the low noise series, and an output impedance of 47  $\Omega$ , single ended. This circuitry is on a small printed circuit board that may be mounted on either a 1/4" TRS jack or a female XLR type jack, both Switchcraft and Neutrik types, or the device may be used card only. The operational amplifiers used are either a TLO71 or 72 with the standard DIA series and a NE5534 or NE5532 in the low noise series.

The DIAs may be purchased with a choice of two connectors, a female XLR type or a 1/4" Tip Ring Sleeve type. The DIAs may also be purchased with no connector. The gain options that are available are; unity, -6 dB, and -12 dB. Additional gain structures may be purchased on a custom basis with surcharge added.

## 2.1 Gain Structures

Most of the applications of the DIAs will be in converting Semi-Pro or High Fidelity equipment to operate in the professional environment. Therefore a loss in amplification is most commonly needed. The choice of gain directly effects the input headroom of the device. All DIAs operating at the power voltage limits, will have an output clip point of approximately +22 dBu. (The dBu is a voltage reference of 0.7746 volts without an impedance reference) The input clip point of a unity gain DIA, operating at the power voltage limit, will be equal to its output clip point. A DIA with 6 dB of loss, however, will have an input clip point that is 6 dB higher than its output clip point, +28 dBu, and a DIA with 12 dB of loss will have an input clip point that is 12 dB higher than its output clip point, +34 dBu. Likewise any custom positive gain structures will directly reduce the input clip point (referenced to unity gain) by the amount of that gain.

In the professional environment, most equipment is capable of putting out +27 to +30 dBu. All of this is to say that if you want to maintain the system dynamic range, input clip points of +27 or higher should be considered necessary in your modified equipment. This necessitates that 6 dB loss be taken in the DIA, and this is what we recommend. If a direct drop from +4 dBu to -10 dBV (-8 dBu) is desired then the -12 dB gain structure may be chosen. In our opinion, however, the 6 dB loss is preferable. This is because most IHF type equipment has an input attenuation potentiometer directly after the RCA pin jack, and the additional loss necessary may be taken at this point. This preserves some gain capability, should it be necessary from time to time, without sacrificing the input clip point.

## 3.0 Unpacking and Installation

As with any delicate electronic equipment, care must be exercised in the handling of this board. Carefully unpack the DIA-1 or 2 and place it on the work table for installation in the intended equipment. Care has been taken during packing to assure the withstanding of normal shipping conditions. Examine the equipment carefully as it is unpacked. If the shipping carton appears to have been damaged

during shipment check the equipment and notify the carrier and Benchmark immediately if there are signs of damage.

### 3.1 Physical Installation

The appropriate holes must be drilled or punched in the intended equipment chassis. For 1/4" jack installation a 3/8" hole should be drilled. From a practical standpoint it is well to start with a small drill size, such as a 1/8", to be used as a pilot hole, with a 1/4" intermediate hole also a genuine help before drilling the 3/8" final size. This will enable more precise location of the jack. If you do not have a deburring tool, a larger drill bit will work for that operation.

**!!! Warning !!!**

**Be careful not to over tighten the nut on the plastic threads of the 1/4" jack. It is very possible to strip the threads on this connector.**

Figure 3.1 shows the drill pattern for the Switchcraft D3F female XLR type connector.

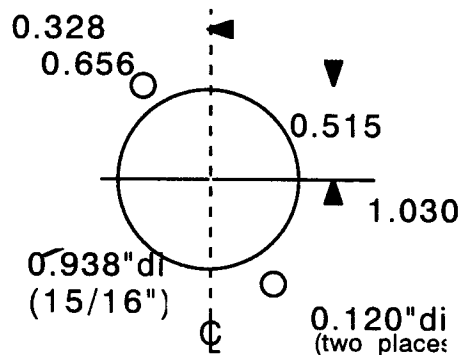

**Fig 3.1 Switchcraft D3F Drill Template**

You may find it convenient to have removed the inner portion of the D3F connector, with the board attached, while mounting the metal portion of the D3F.

### 3.2 Electrical Installation

The DIA-1 must be powered from bipolar supplies. The power voltage range is from  $\pm 9$  to  $\pm 18$  volts for the standard series, and to  $\pm 22$  with the low noise series. If the devices need to be installed in equipment that have high voltage supplies only, such as in power amplifiers, on board zener regulation may be added. A group of three wires at the rear of the DIA-1 are used to bring power into the device. The red wire must connect to the positive supply, the blue wire to the negative supply, and the black wire ties to the power supply common point. See figure 3.2 for the correct pin assignments.



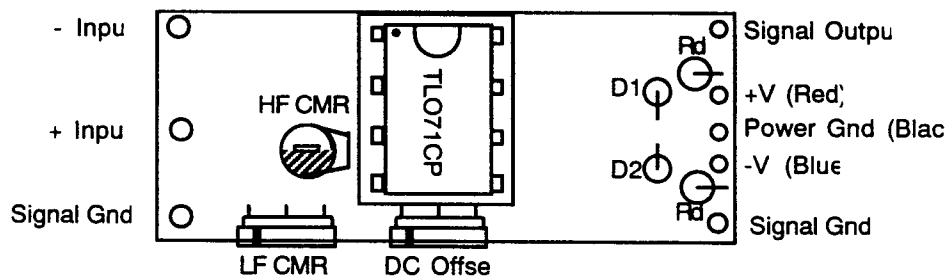

Fig 3.2 DIA-1 Connections and Controls

The DIA-2 must be powered from a single positive supply. The power voltage range is from +18 to +36 volts for the standard series, an to +44 volts for the low noise series. Two wires at the rear of the DIA-2 are used to bring power into the device. The red wire must be connected the supply's positive terminal and the black wire to the supplies negative terminal. See figure 3.3 for the correct pin assignments.

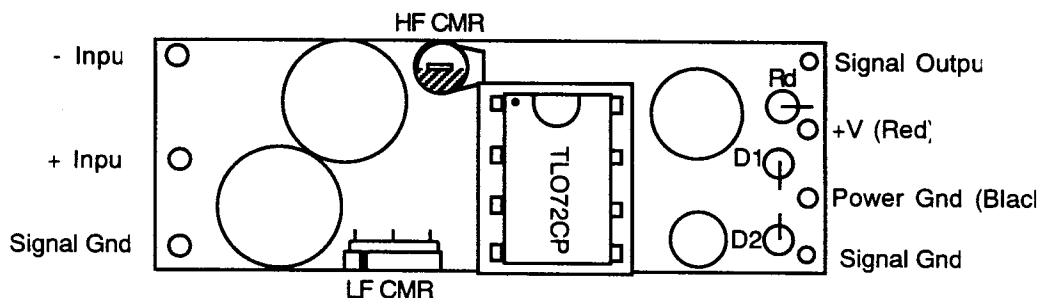

Fig 3.3 DIA-2 Connections and Controls

Output connections are made at the right end of the board. Output wires should be soldered to the two extreme outside holes. The output signal to the top hole and the ground to the bottom hole. The input connections, shown on the left end of the board are solder connections if you ordered "board only". The inputs, as identified on the pictorial, are correct for the board only, the 1/4" TRS jack, and for the XLR type connector.

### 3.2.1 Power Connections

Use the highest power supply voltage possible within the constraints of the op-amp limits. Often within a piece of equipment you will find both unregulated voltages of  $\pm 15$  to  $\pm 18$  volts as well as  $\pm 9$  to  $\pm 12$  volts regulated (+30 and +24 respectively for the DIA-2). It is sometimes possible to power the DIA-1 or 2 using the raw DC voltages, provided the ripple content is very low, but since the NE5532 and NE5534 do not have high power supply rejection ratios, caution must be exercised when doing this. Using the highest voltage available will give the best headroom, but high ripple content will degrade the signal to noise ratio, particularly in the annoying 120 Hz range. So use this option only if you can measure the results of your work.

Once again the maximum supply voltage that the TLO series op amps may use is  $\pm 18$  volts (+36 on the DIA-2) and  $\pm 24$  on the DIA-1-LN (+48 on the DIA-2-LN). Powering the amplifiers from higher voltages than these, must be accomplished using the optional on board zener regulation. When installing the DIA-1 or 2 in a power amplifier, it is preferable to power the device from the high voltage power supply by using this zener regulation. The  $\pm 10$  volt supply that exists in many of the

CROWN power amplifiers will limit the headroom of the DIA-1 by approximately 3.5 dB.

There is no limitation to the maximum power supply voltage that may be used when using zener regulation. The physical space limitations necessary for the dropping resistors limit the maximum supply voltage to  $\pm 42$  volts in the case of the DIA-1 and +58 volts in the case of the DIA-2. Higher supply voltages than these require the dropping resistors be mounted external to the DIA board. A convenient place to mount the external dropping resistors is directly at the power amplifiers filter capacitors. The chart on the schematic lists the appropriate resistor values for varying supply voltages. A set of dropping resistors is necessary for each DIA board to be installed within a power amplifier. The values for resistors not listed for the DIA-1 may be calculated by

$$R = \frac{V_{ps} - 18}{0.01} \Omega \quad [3.1]$$

and the power rating of the resistor may be calculated by

$$P_r = (V_{ps} - 18) \times 0.02 \text{ Watts}, \quad [3.2]$$

rounded off to the next higher standard power rating. The formulas for the DIA-2 are

$$R = \frac{V_{ps} - 36}{0.01} \Omega \quad [3.3]$$

and

$$P_r = (V_{ps} - 36) \times 0.02 \text{ Watts}, \quad [3.4]$$

again rounded to the next higher standard power rating.

For example, the DIA-1 will power from the following;

<u>Bipolar Supplies</u>	<u>R<sub>d</sub></u>	<u>P<sub>r</sub></u>
$\pm 60$ Volt Supplies	4500 $\Omega$	1 Watt
$\pm 70$ Volt Supplies	5500 $\Omega$	1 Watt
$\pm 80$ Volt Supplies	6500 $\Omega$	2 Watt
$\pm 90$ Volt Supplies	7500 $\Omega$	2 Watt

### 3.2.2 Input and Output Connections

If the DIA-1 or 2 was purchased with a connector attached, then of course no input connections need to be made to the board. If you purchased a board only, then the intended input wires must be soldered to the P.C. board according to figures 3.2. and 3.3 The unbalanced output connection must also be made. Use the Figure 3.2 and 3.3 to identify the correct hole locations.

### !!! Warning !!!

The DIA 1&2 are constructed on single sided printed circuit boards that may be easily damaged by excessive heat while soldering. It is very easy to "lift" a run from the board hence extreme caution must be exercised during the soldering process. We strongly recommend the use of a temperature controlled soldering station, set for a temperature of 600°. See the section on soldering in the Troubleshooting and Repair section 4.0

The DIA-1 is a DC coupled device, therefore you must be sure that no DC voltage is present at the output of the original equipment. If this is not done the DIA-1 will amplify this DC voltage. If DC is present, 100  $\mu$ F aluminum electrolytic capacitors should be installed between the signal source and the input of the DIA-1. This large a capacitor is necessary to preserve the common mode rejection ratio of the DIA-1. Even larger capacitors are needed for the DOA-1-LN, and 330  $\mu$ F, or larger, capacitors are recommended. The DIA-2 has no need for further isolation, as it already is an AC coupled device. Connect the existing input lead (original input in equipment) to the signal output of the DIA board.

When connecting the power and signal wires of the DIA-1 to their respective points, you should be aware of the jumper strap that ties the power ground and the signal ground together. This jumper offers an option for the installer. While there is normally no problem, it is possible to separate the power and signal grounds as a means of achieving hum free audio. It is our experience that this option is rarely needed since there is very little current flowing in the ground lead, unless the zener option is installed on the card, and then only to the amount allowed by the combined tolerance limits of those components.

The "ground" lead is the signal reference, therefore it is important where this lead is connected. We have found that some bipolar power supply common points are not necessarily a clean audio reference, whereas, the signal ground originally used with the equipment is almost always a good reference point. Care at this point is necessary in order to achieve the noise floor as a system, to which the DIA is capable. Perform close noise measurements and/or careful listening tests under high gain, to determine the result of your work.

#### 3.2.2.1 Equipment Interconnection

Connect the output of the equipment that is feeding the newly modified piece (in which the DIAs were installed) in the following fashion. Balanced outputs are connected using both the black wire as the inverting and red wire as the non-inverting signal path in normal foil shielded audio cable. Connect the non-inverting output to non-inverting input and inverting output to inverting input. The shield of the interconnecting cable should be connected at only one end, either the output end or the input end. Additionally a separate insulated wire should tie the pieces of equipment together. See the Benchmark Media application note, "A Clean Audio Installation Guide" by Allen H. Burdick for the particulars as to how this external wire should be connected.

Unbalanced feeds should be connected to the input of the DIA in a similar fashion with the exception of the black wire (inverting input), which should connect to the

signal reference (usually chassis ground) of the sending equipment. This is known as forward referencing. It allows the DIA to reject voltage differences between the two pieces of equipment. Again see the "Clean Audio Installation Guide".

### !!! Notice !!!

It is not uncommon for the manufacturers of high fidelity and semi-professional equipment to place a series resistor between the output of the internal amplifier and the RCA connector, whose value may be as high as 10 k $\Omega$ . The purpose of this resistor is to protect against those who would "mix" two outputs via a "Y" connector. This resistor will destroy the exceptional common mode rejection expected from the DIA and hence it should be removed.

### 3.2.3 Output Impedance

The output impedance of the DIAs is 47  $\Omega$  resistive. The purpose of this resistor is to isolate cable capacitance from the operational amplifiers output and thus preserve its phase margin. These devices are designed to work into input impedances not lower than 2 k $\Omega$ . If you intend to drive a long line, from 10' to 300' with your input unit, you will need to use a DOA line driver. If you have to drive a line longer than 300' then a CBO-1, with its high current output capability is the appropriate line driving device. This is due to the current requirements that are necessary to feed the cables capacitance at high frequencies. Further information on this may be found in "A Clean Audio Installation Guide".

### 3.2.4 Trim Adjustments

All of the variable controls on the DIAs are for factory presets, and are not user adjustments.

### !!! Warning !!!

The factory sealed adjustments must not be adjusted by the installer or user without precise measuring equipment and a knowledge of the circuit parameters affected. These are not gain controls.

The DIA-1 has three controls that are sealed. Two of these are the common mode rejection adjustments and the third is a DC offset null. The DIA-2 has only the two common mode rejection adjustments.

If you have strong reason to believe that any of the factory presets have been changed or are not correct then the following procedure may be used to correct these settings.

#### 3.2.4.1 DC Offset Adjustment

The DC offset control, shown in figure 3.2, allows the "no signal" DC voltage at the output of the DIA-1 to be adjusted to near zero volts. To perform this adjustment a 4 $\frac{1}{2}$  digit DVM, with 0.05% accuracy or better, is necessary. We recommend the Fluke 8050A voltmeter.

1. With no signal present, connect the voltmeter to the output of the DIA-1

2. Measure the output voltage and adjust it as close to zero as possible. This should be at least lower than 1.0 millivolt and in many cases may be adjusted to less than 10 microvolts. The resolution of the 8050A is 10  $\mu\text{V}$ . The DIA should not be expected to maintain this low an offset voltage under varying temperature conditions. Op-amp thermal instabilities will prevent the tight maintenance of this setting over temperature. Therefore, if it is possible, adjust the offset voltage at or near the temperature the device will see in actual use.

### 3.2.4.2 Common Mode Rejection Adjustment.

Common mode rejection adjustment must be performed using an oscillator with a "single ended" output (ground referenced), a function generator will work very well and a sensitive, wideband analog, AC type voltmeter. The voltmeters found in distortion analyzers with sensitivities down to -100 dBu or better are good. A digital voltmeter is not a proper choice for this measurement. Most preferable, however, is a logarithmic type voltmeter, such as those formerly made by **dbx** and Valley People. Unfortunately these are no longer available, except perhaps on the used market. Additionally an oscilloscope is very advantageous in this test setup. The oscilloscope should receive its signal from the output of the voltmeter, where the voltmeter is acting as a preamplifier for the scope. The scope should be triggered from the output of the function generator.

Connect the test equipment to the Differential Input Amplifier as shown in figure 3.4

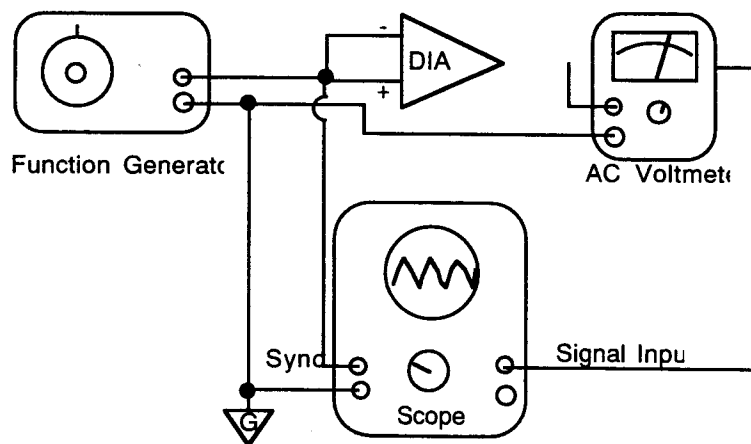

Fig 3.4 CMR Test Setup

The common mode rejection adjustment is actually a series of iterative adjustments between the resistive portion of the bridge and the capacitive portion. This adjustment should be performed at a frequency of 2 kHz.

Adjust the trim resistor for the best null possible at the output of the DIA while observing the voltmeter. If you have an oscilloscope as a part of your test setup, observe the phase shift of the remnant signal as you pass through a voltage minimum. The phase change is a more easily observable parameter when near the voltage minimum than is the voltage itself. Set the potentiometer for the center of the phase shift, and then proceed to the capacitive adjustment and adjust for a further reduction in output voltage. You will most likely need to switch the voltmeter to progressively lower ranges during this process. You will find the adjustments progressively more sensitive. Observing the

oscilloscope will allow a significantly faster achievement of the desired null.

The common mode adjustment involves passive components that form a bridge around the active operational amplifier and this adjustment is independent of the operational amplifier. If an amplifier integrated circuit ever needs replacing, the common mode rejection adjustments will not need to be performed. The only possible exception to this would be the equivalent of a lightning strike that would take out or change the values of these passive components, in which case those parts would also need to be changed.

#### **4.0 Troubleshooting and Repair**

The DIA-1&2 are carefully constructed of very high quality components and therefore will probably never need servicing. Should a problem occur with your device, the following will aid in locating the problem.

The first step in troubleshooting, is to check for solder shorts and other mechanical problems that may have occurred during the installation. Many of the problems with electronic circuits may be solved by close visual inspection. We heartily recommend the use of an "OptiVISOR", manufactured by Donegan Optical Co., or an equivalent stereo optical magnifier.

If after inspection you have determined that no solder bridges were created during installation, the DC operating voltages should be checked. First determine that the proper power voltages exist at the pins of the operational amplifier, pins 4 and 7 on the DIA-1 and pins 4 and 8 on the DIA-2. With the DIA-1 a positive voltage, referenced to ground, at pin 7 (the full power supply voltage) should be present. Likewise a negative voltage at pin 4 should be present. In the case of the DIA-2, pin 4 is ground and pin 8 should have the full power voltage present. The output pins of the amplifier should be checked next, that is, pin 6 on the DIA-1 and pin and 7 on the DIA-2. The DIA-1 should have less than 5 mV at its output, and in reality 100  $\mu$ V or less, should be typical. These measurements should be made with no audio signal present. The DIA-2, on the other hand, should have a voltage that is nearly one half that of the power voltage present at its outputs. If the output voltages are not correct, under no signal conditions, the replacement of the operational amplifier will in most cases fix the device.

On extremely rare occasions a faulty passive component may exist. If you are unable to locate the problem, a reasonable amount of troubleshooting assistance is available, via telephone, from the customer service department at Benchmark Media Systems.

#### **4.1 Soldering Technique**

Once the faulty component is isolated extreme caution must be exercised when removing the component and soldering in a replacement. Benchmark strongly recommends the use of a vacuum de-soldering station such as the Pace MBT-100.

The proper technique is to apply the de-soldering iron tip to the area to be de-soldered and wait for the solder to liquefy. As the solder becomes liquid the vacuum is applied while moving the tip of the iron and rotating the lead of the component coming through the circuit board. Rotate the lead without applying pressure to the pad. If this procedure is correctly applied the component will often drop from the circuit board.

The following is a soldering technique that was developed by NASA to ensure highly reliable solder joints.

The component lead is heated first since it usually has the larger mass and has little chance of being damaged by excess heat. This is done by applying a small amount of solder to the tip of the soldering iron while simultaneously applying the iron to the component lead. This allows some flux to make it to the component lead. The iron should be slightly above the circuit board. When the lead reaches temperature it liquefies the solder adjacent to it and has good wetting. Slide the soldering iron down the lead and heat the printed circuit board pad while applying a controlled amount of solder to the joint. All of this should take no longer than a couple of seconds.

The component to be mounted on the circuit board may have leads that are oxidized. Clean them with a "Scotch Bright" abrasive pad, a fine bristle fiberglass brush or equivalent method.

This completes the DIA-1&2 instruction manual.

030392

**BENCHMARK MEDIA SYSTEMS, INC.**  
5925 Court Street Road Syracuse, NY 13206-1707  
(315) 437-6300 FAX (315) 437-8119

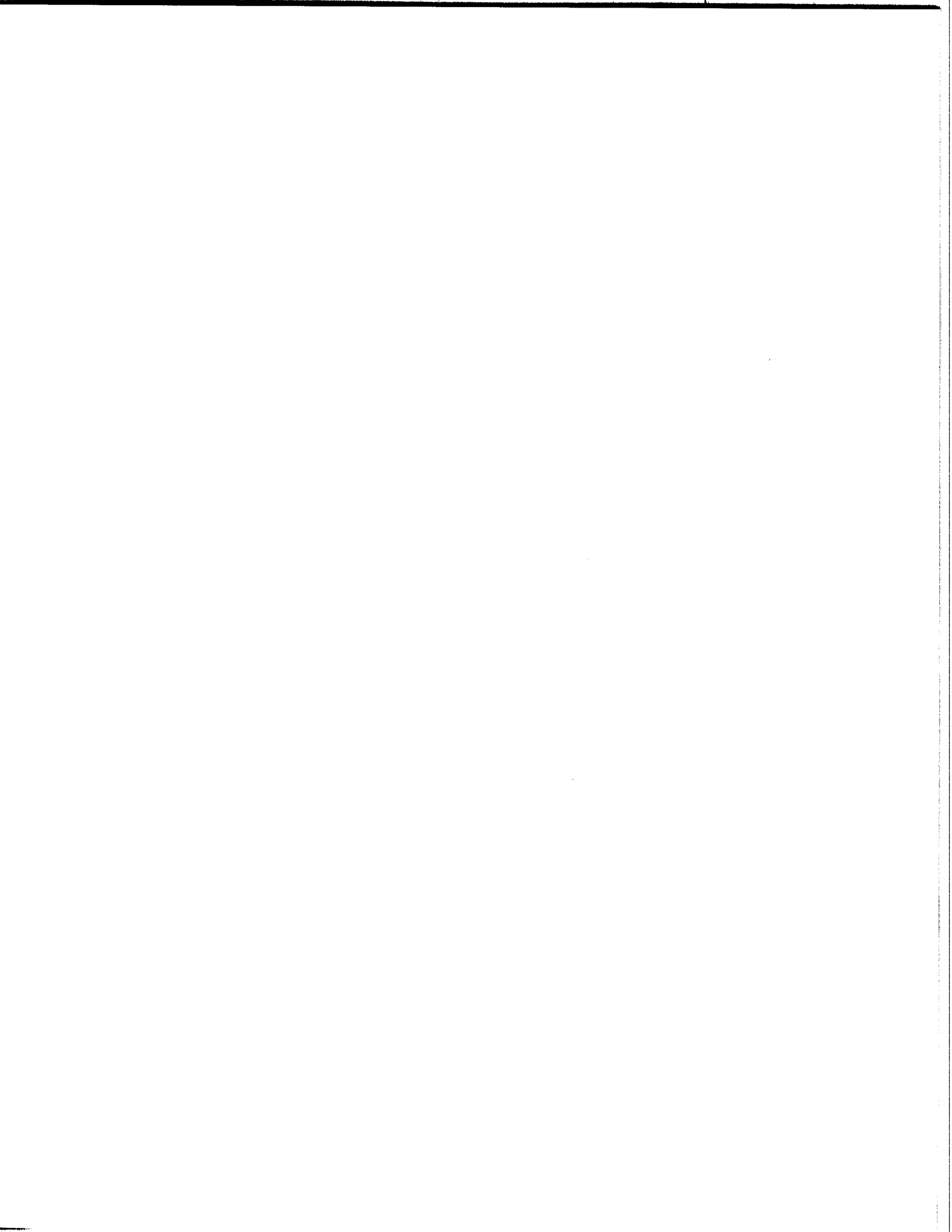





**BENCHMARK MEDIA SYSTEMS, INC.**

**DOA-1,2 and 3 Instruction Manual**

Table of Contents

1.0 Introduction .....	1
2.0 General Features.....	1
3.0 Unpacking and Installation.....	1
3.1 Physical Installation.....	1
3.2 Electrical Installation .....	2
3.2.1 Power Connections.....	3
3.2.2 Input and Output Connections.....	3
3.2.3 Output Impedance.....	3
3.2.4 Balanced or Single Ended Outputs.....	4
3.2.5 Terminations and Output Amplitude.....	4
3.2.6 Gain Control and D.C. Offset.....	5
3.2.7 Remote Installation of the Gain Control.....	5
4.0 Troubleshooting and Repair.....	6
4.1 Soldering Technique .....	6
4.2 Circuit Board Re-Soldering .....	7
5.0 Component Assembly .....	9
6.0 Electrical Schematic .....	10

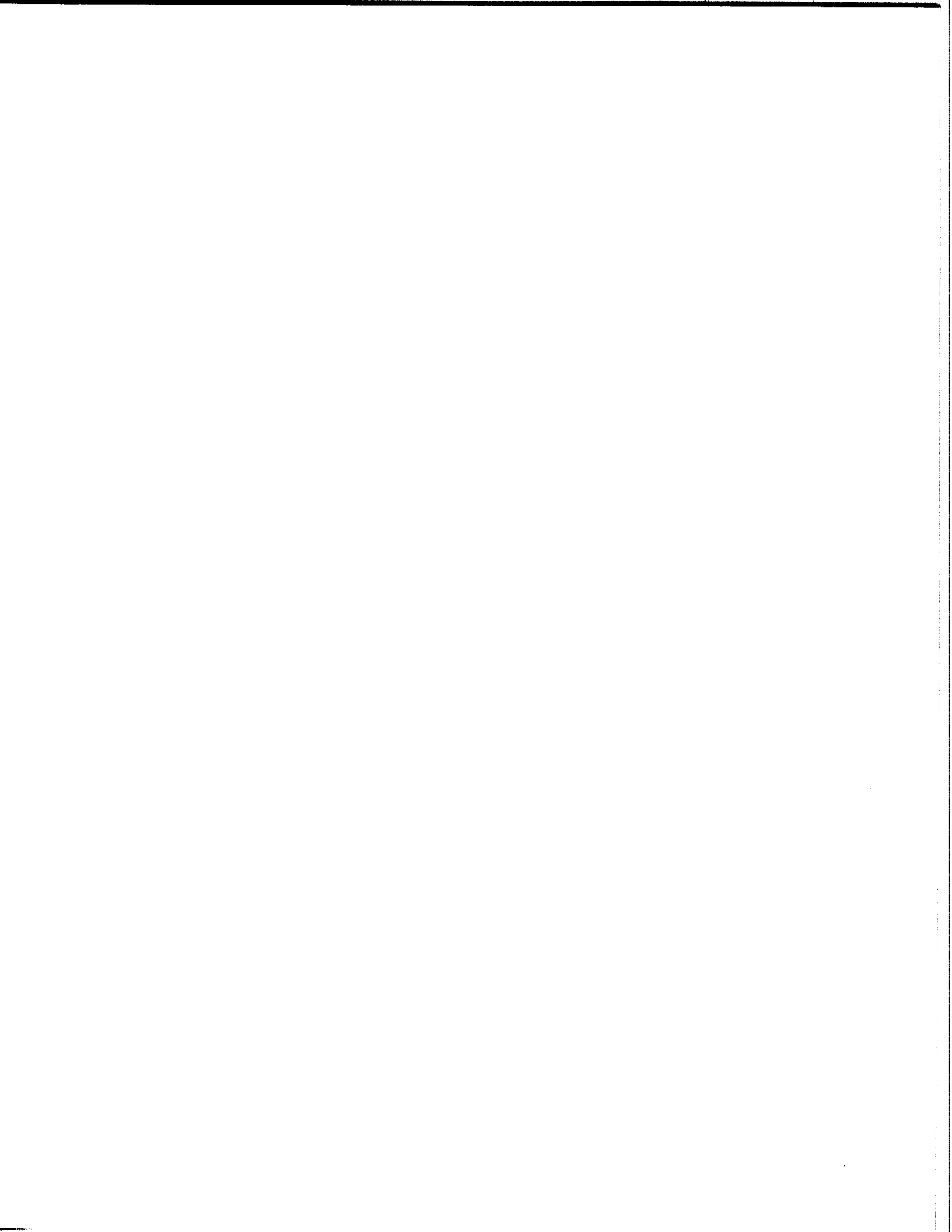

## 1.0 Introduction

The DOA-1, 2 & 3 Differential Output Amplifiers are universal output devices designed to provide both a balanced output and the gain necessary to interface consumer and semi-professional audio equipment to the professional environment.

## 2.0 General Features

The DOA-1, 2 & 3 balanced output devices have variable gain from full Off to +26 dB, an output impedance of 60 ohms, an input impedance that varies with the amplification factor that is used (100 k $\Omega$  max, 10 k $\Omega$  min) and in the case of the DOA-1, an adjustable DC offset voltage trim that is set by the user. Both the DOA-1 and 3 are for use with bipolar power supplies, while the DOA-2 is for use with a single "plus" supply. The DOA-1 is a DC coupled device. The DOA-3 is similar to the DOA-1 but with an AC coupled output stage. It has output coupling capacitors and is minus the DC offset circuitry. The DOA-3 satisfies the need for a bipolar powered device that allows continuously adjustable output level without the problem of continuously changing DC offset voltage.

All circuitry is on small printed circuit boards that may be mounted on either a 1/4" TRS jack or an XLR type jack, both Switchcraft and Neutrik types, or it is also available as card only. The operational amplifier used is a NE5532 for outstanding aural performance.

## 3.0 Unpacking and Installation

As with any delicate electronic equipment, care must be exercised in the handling of this board. Carefully unpack the DOA-1, 2 or 3 and place it on the work table for installation in the intended equipment. Care has been taken during packing to assure the withstanding of normal shipping conditions. Examine the equipment carefully as it is unpacked. If the shipping carton appears to have been damaged during shipment check the equipment and notify the carrier and Benchmark immediately if there are signs of damage.

## 3.1 Physical Installation

The appropriate holes must be drilled or punched in the equipment chassis intended to receive the DOA. For 1/4" jack installation a 3/8" hole should be drilled. From a practical standpoint it is well to start with a small drill size, such as a 1/8", as a pilot hole. A 1/4" intermediate hole also a genuine help before drilling the final 3/8" size. This will enable more precise location of the jack. If you do not have a de-burring tool, a larger drill bit will work for that operation.

### !!! Warning !!!

Be careful not to over tighten the nut on the plastic threads of the 1/4" jack. It is very possible to strip the threads on this connector.

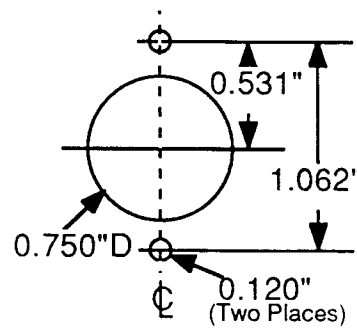
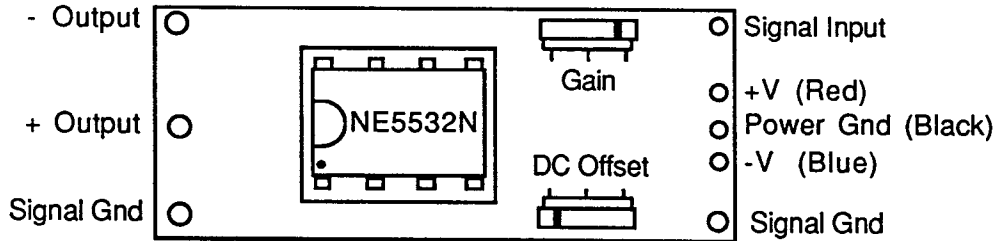

Fig 3.1 Switchcraft D3M Drill Template

Figure 3.1 shows the drill pattern for the Switchcraft D3M connector. Drill the appropriate holes and mount the DOA-1, 2 or 3.

### 3.2 Electrical Installation

The DOA-1 must be powered from bipolar supplies. The power voltage range is from  $\pm 9$  to  $\pm 24$  volts. A group of three wires at the rear of the DOA-1 are used to bring power into the device. The red wire must connect to the positive supply, the blue wire to the negative supply, and the black wire to the power supply common point. See figure 3.2 for the correct pin assignments. The output connections shown are for Tip Ring Sleeve type 1/4" jack or board only, but not for the XLR type connector. For the XLR connector the inverting output and the signal ground pins are reversed.



**Fig 3.2 DOA-1 Connections and Controls**

The DOA-3, has the same powering requirements and signal inputs as the DOA-1. See figure 3.3. Once again the inverting output and the signal ground positions are for the 1/4" connector or board only, not for the XLR type connector.

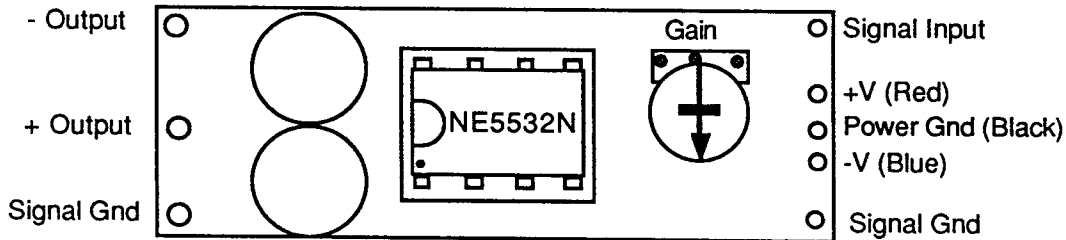

**Fig 3.3 DOA-3 Connections and Controls**

The DOA-2 must be powered from a single positive supply. The power voltage range is from +18 to +44 volts. Two wires at the rear of the DOA-2 are used to bring power into the device. The red wire must be connected to the supply's positive terminal and the black wire to the supply's negative terminal. See figure 3.4 for the correct pin assignments.

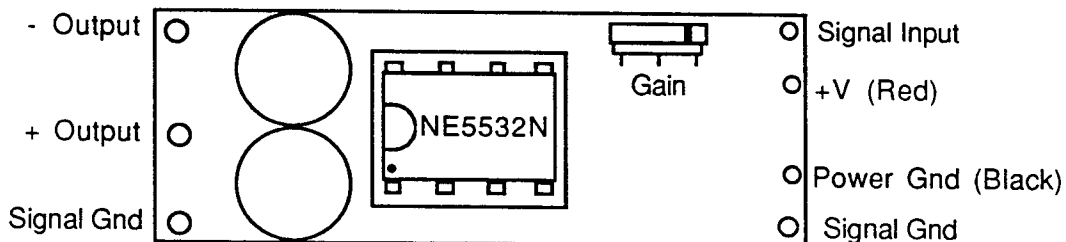

**Fig 3.4 DOA-2 Connections and Controls**

Input connections are made at the right end of the board. Input wires should be soldered to the two extreme outside holes, the input signal to the top hole and the ground to the bottom hole.

The output connections, as identified on the pictorial, are correct for the board only and the 1/4" TRS jack, but not for the XLR type connector.

### 3.2.1 Power Connections

Use the highest power supply voltage possible within the constraints of the op-amp limits. Often within a piece of equipment you will find both unregulated voltages of  $\pm 15$  to  $\pm 18$  volts as well as  $\pm 9$  to  $\pm 12$  volts regulated (+30 and +24 respectively for the DOA-2). It is sometimes possible to use the raw DC voltages, provided the ripple content is very low, to power the DOA-1, 2 or 3. But since the NE5532 does not have good power supply rejection, caution must be exercised when doing this. Using the highest voltage available will give the best headroom, but high ripple content may degrade the signal to noise ratio, particularly in the annoying 120 Hz range. So use this only if you can measure the results of your work.

The maximum power supply voltage allowed by the manufacturer of the operational amplifier is  $\pm 22$  volts (+44 for the DOA-2).  $\pm 18$  (+36) volts however will allow a cooler device. The use of  $\pm 22$  (+44) volt supply rails results in an increase in quiescent current drawn by the op-amps. The resultant heating of the chip increases the input bias currents. As the chip gets hot, the output current limit point is reduced, and if the device actually should have a 600 load (not recommended) the maximum output capability is actually LOWER than if the power supply voltage were at  $\pm 18$  volts. On the other hand some audio equipment uses  $\pm 24$  (+48) volt power supplies, and it is desirable to maintain the same output voltage capability with the addition of the differential output amplifiers. It is our experience that the NE5532 will work without loss of reliability with these limits even though they are beyond the specification given by the manufacturer, provided the output feeds a bridging input. The chip will, however, run very warm to the touch.

### 3.2.2 Input and Output Connections

If the DOA-1, 2 or 3 was purchased with a connector attached, then of course, no output connections need be made to the board. If you purchased a board only, then the intended output wires must be soldered to the PC board according to figures 3.2. and 3.3 The unbalanced input connection must also be made as discussed above. Use the Figure 3.2, 3.3 and 3.4 to identify the correct hole locations.

### !!! Warning !!!

The DOA 1, 2 & 3 are constructed on single sided printed circuit boards that may be easily damaged by excessive heat while soldering. It is very easy to "lift" a run from the board. Therefore extreme caution must be exercised during the soldering process. We strongly recommend the use of a temperature controlled soldering station, set for 600°F. See the section on soldering in the Troubleshooting and Repair section 4.0

The DOA-1 is a DC coupled device, therefore you must be sure that no DC voltage is present at the output of the original equipment. If this is not done the DOA-1 will amplify this DC voltage. If DC is present, a 10  $\mu$ F aluminum electrolytic capacitor should be installed, observing voltage polarities, between the signal source and the input of the DOA-1.

The DOA-3 should be treated the same as the DOA-1. While there is no input coupling capacitor, any amplified DC will reduce the headroom of the amplifier. Also, DC on the input presents the possibility of a polarity inversion on the output coupling capacitors.

The DOA-2 has no need for further isolation, as it already is an AC coupled device.

### 3.2.3 Output Impedance

The output impedance of the DOAs is 60 ohms balanced, 30 ohms unbalanced. This is achieved with 1% metal film build-out resistors. A 60 ohm output has been found to be the optimum drive impedance for today's foil shielded cables. This allows the longest possible cable runs to

be made without excessive high frequency roll-off and without significant high frequency response peaking.

If the shielded pair being used has 32 pf/foot capacitance between conductors (not shield) then for a system high frequency cutoff of say 30 kHz, the maximum length of cable that may be used is 2947 feet, or approximately 900 meters. This is ten times the length possible, under the same constraints, if the output impedance were 600 ohms, with a bridging input.

The total C is determined by:

$$C = \frac{1}{2 \pi f_c R} \quad [3.1]$$

where in this case C is the maximum allowable cable capacitance, R is the output impedance, in this case 60 ohms, and  $f_c$  is the lowest system high frequency cutoff that we can tolerate. Obviously using low capacitance cable will further improve our limits.

The total number of feet of whatever cable chosen is found by:

$$\text{Feet max} = \frac{C}{\text{Cable pf/ft}} \quad [3.2]$$

Using the DOA-1, 2 or 3, the maximum cable length that may be driven, from the standpoint of available current (40 mA peak) to feed the cable capacitance, is approximately 300' at 32 pF/foot. Belden 9700 series, a foil shielded data transmission cable line, at 12 pF/foot, and Mogami 2574 at 6 pF/foot allow proportionally longer lines to be driven. See "A Clean Audio Installation Guide" by Allen H. Burdick, A Benchmark Media Systems application note.

### 3.2.4 Balanced or Single Ended Outputs

The DOA-1, 2 or 3 can be used either as balanced or a single ended output driver. When used as a balanced output device, both of the outputs, inverting and non-inverting will, of course, be utilized. When used as a single ended output for its gain capability only, be sure only one of the two outputs is utilized, either the inverting or the noninverting. Under no circumstances should an output be tied to ground as would be done with a transformer type output. Unlike transformer type outputs, the active balanced output is already ground referenced.

**!!! Warning !!!**

Tying one of the outputs to ground will cause a large amount of distortion to occur as well as overheating of the operational amplifier.

### 3.2.5 Terminations and Output Amplitude

As already indicated, the impedance matched audio interconnect system developed in the days of tube amplifiers is now passé for anything but extremely long cable runs. With modern operational amplifier technology it is no longer necessary nor even desirable to terminate audio lines with a "matched" low impedance, unless you are the Phone Co. with miles of cable, the length of which approaches 1/4 wavelength at the highest frequency of interest, i.e. 2.33 miles at 20 kHz.

Today the voltage sourced interconnect system is becoming universally used. The voltage sourced system features a low source impedance of approximately 50 to 60 ohms, and a high input impedance of 10 K ohms or higher. The advantages are:

1. Less power drawn from the source equipment, therefore less heat generated.
2. Lower distortion generated by the output stage doing the driving.

3. 14 dB lower noise pickup by the interconnect lines due to the lower source impedance.

The DOA-1, 2 & 3 were designed with this in mind and while they will drive a 600 ohm load, they do so with reduced headroom (lower clip amplitude) due to the internal current limiting of the op-amp used. Additionally there is a not insignificant increase in distortion generated by the operational amplifier. Therefore, for the best headroom and system performance, DON'T put a 600 ohm resistor at the receiving end of the cable being driven by either the DOA-1, 2 or 3. The only exception to this might be in a high RF environment, where the resistor could tame the line in terms of RF power.

PS Voltage & Ques I	Max Out Unterm.	Max out 600 Ω Term.
+44 or ±22 V @ ±12.0 mA	+30 dBu	Op-amp overheats
+36 or ±18 V @ ±9.50 mA	+28 dBu	+26 dBu
+30 or ±15 V @ ±8.60 mA	+26 dBu	+25 dBu
+24 or ±12 V @ ±7.75 mA	+24 dBu	+23 dBu
+20 or ±10 V @ ±7.50 mA	+22 dBu	+21 dBu
+18 or ±9 V @ ±7.50 mA	+21 dBu	+20 dBu

**Fig 3.3 DOA Output Limits and Quiescent Current**

The maximum output from the DOA operating as an unbalanced output is always 6 dB lower (1/2 the voltage available) than when operating as a balanced output.

### 3.2.6 Gain Control and D.C. Offset

The gain of the DOA-1, 2 & 3 is adjustable from full Off to +26 dB balanced or +20 dB unbalanced. Because these devices use the potentiometer within the feedback loop of the amplifier, optimum signal to noise ratio is always maintained. This is because only the amplification necessary to perform the task is asked of the op-amps. The output noise at maximum amplification is -85 dBu and at minimum amplification is -105 dBu. 0 dBu is equal to 0.7746 volts RMS. Therefore at the manufacturer's recommended maximum power supply voltage of ± 22 volts and at maximum amplification, the dynamic range of the DOAs is 115 dB (-85 dBu to +30 dBu). Worst case (minimum power voltage of ±9 volts) the dynamic range is -85 dBu to +21 dBu = 106 dB. Best case performance, at unity gain or less, yields a total dynamic range of 130 dB.

Since the DOA-1 is a DC coupled device it is necessary to adjust the offset voltage once the device has been fully installed and its gain set. We recommend the use of the Fluke 8050A for this operation if possible, since it has a resolution of 10 μV at maximum sensitivity. If you are going to use the unit as an unbalanced output then adjust the offset voltage while measuring between the chosen output and ground. If the device is used as a balanced output, then the trim should be made while measuring between the two outputs. This adjustment must be made with no audio signal passing through the amplifier.

### 3.2.7 Remote Installation of the Gain Control

The on board potentiometers of the DOA-2 and DOA-3 may be removed and 100 kΩ linear taper panel potentiometer potentiometers may be substituted. The principal thing to be remembered is that the summing node of the amplifier is one on these leads and needs to be kept as short as possible to avoid hum pickup. Twisting the wires will aid somewhat in hum rejection.

If you already own DOA-1s and not DOA-3s, it may be desirable to do the following modification and add the components that are already on the DOA-3. Output capacitors must be added to isolate the continuously varying offset voltage from the equipment being fed. It is most desirable to use 100 μF or larger capacitors to preserve the common mode rejection of the input stage that is receiving this signal. Additionally, 100 kΩ resistors should be connected between the output (after the capacitors) and ground to drain leakage currents. See Figure 3.5



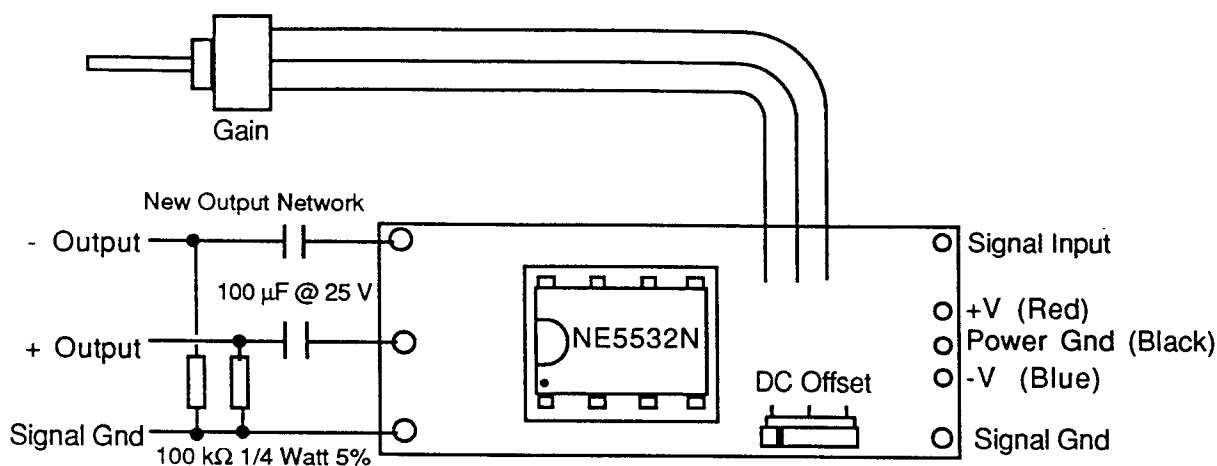

**Fig 3.5 Remote Gain – Output Capacitors for DOA-1**

#### 4.0 Troubleshooting and Repair

The DOA-1, 2 & 3 are carefully constructed of very high quality components, thoroughly tested before shipment and therefore will probably never need servicing. Should a problem occur with your device, the following will aid in locating the problem.

The first step in troubleshooting, is to check for solder shorts and other mechanical problems that may have occurred during the installation. Many problems may be solved by close visual inspection. We heartily recommend the use of an “OptiVISOR”, manufactured by Donegan Optical Co., or equivalent stereo optical magnifier.

If inspection reveals that no solder bridges were created during installation, the DC operating voltages should be checked. First determine that the proper power voltages exist at pins 4 and 8 of the operational amplifier. With the DOA-1 & 3 a positive voltage, referenced to ground, at pin 8 (the full power supply voltage) should be present. Likewise a negative voltage at pin 4 should be present. In the case of the DOA-2, pin 4 is ground and pin 8 should have the full power voltage present. The output pins of the amplifier should be checked next, that is, pins 1 and 7 on both devices. The DOA-1 should have less than 5 mV at either output after trimming, and in reality 100 µV or less, is not unreasonable. Again, these measurements should be made with no audio signal present. The DOA-2, on the other hand, should have a voltage that is nearly one half that of the power voltage present at both outputs. The DOA-3 will have a DC offset voltage that is dependant upon the gain of the amplifier, but in any case should be less than 0.2 volts either positive or negative. If the output voltages are not correct, under no signal conditions, the replacement of the operational amplifier will in most cases fix the device.

On extremely rare occasions a faulty passive component may exist. If you are unable to locate the problem, a reasonable amount of troubleshooting assistance is available, via telephone, from the customer service department at Benchmark Media Systems.

#### 4.1 Soldering Technique

Printed circuit boards are very easy to damage by excessive heat. Unless you have developed the specialized skills necessary to remove and replace components, we suggest that you leave the task to someone skilled in these techniques.

When servicing printed circuit boards we strongly recommend the use of a vacuum de-soldering station, such as the Pace MBT-100. The proper technique with these stations is to apply the tip to the area to be de-soldered and wait for the solder to thoroughly melt. When the solder has become liquid, apply the vacuum while moving the hollow tip with the component lead in a circular motion. By rotating the lead, with the tip against the board, but without applying pressure to the pad, you are able to most thoroughly remove the solder. In turn the component will often drop out of the circuit board when you are finished.

#### **4.2 Circuit Board Re-Soldering**

NASA has developed an effective technique that ensures highly reliable solder joints. It involves first heating the component lead, since it usually has the higher mass, by applying a small amount of solder to the tip of the soldering iron at almost the same time as you apply the iron to the component lead. This will allow some flux to make it to the component lead. The iron should be approximately 1/8" above the board. When the lead has come up to temperature so that it melts the solder when placed against it and has good wetting, slide the soldering iron down the lead and heat the printed circuit board pad while applying a controlled amount of solder to the joint. All of this should take no more than a couple of seconds. If the component that is to be installed has leads that are oxidized, it will be necessary to clean them. This may be done with either a Scotch Bright® abrasive pad or fine bristle fiberglass brush, among other methods.

This completes the DOA-1, 2 & 3 instruction manual.

Ed. 13 March 1988

**BENCHMARK MEDIA SYSTEMS INC.**

5925 Court Street Road  
Syracuse, NY 13208  
Phone (315) 437-6300, FAX 437-8110

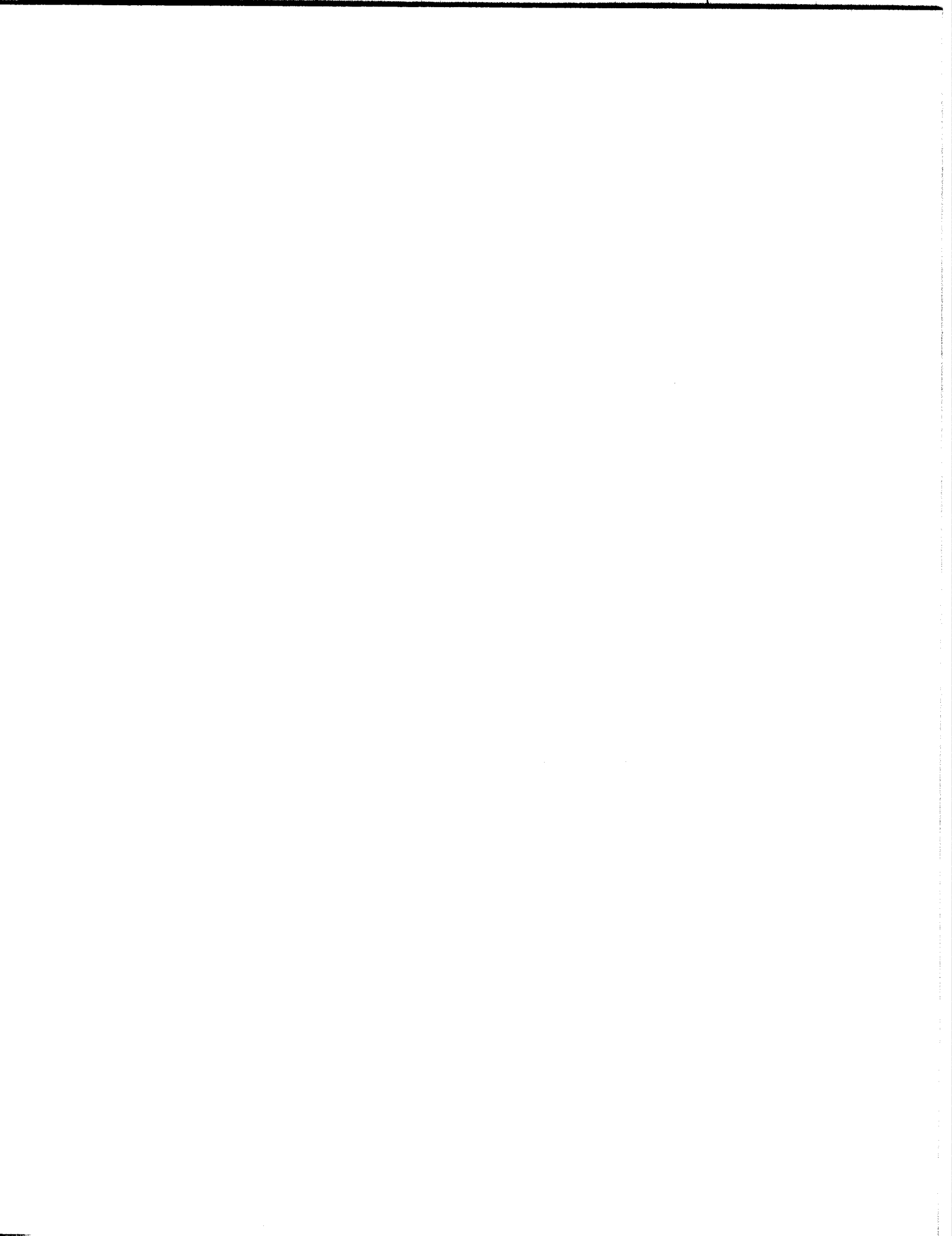

REVISIONS

A SEE DCN NO. 49

12/20/88

J.R.P.

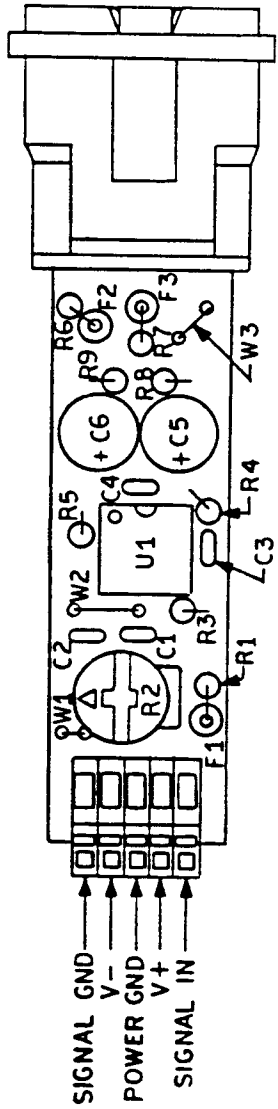

Benchmark Media Systems

DOA-3

SCALE	CHECKED BY	DRAWN BY
		J.R.P.
DATE		
2/11/88	<i>A.H. Emlich</i>	
1/28	COMP ASS'Y	DRAWING NO. 250033

BRAND GRAPHICS, INC.  
 FORM NO. 154

REVISIONS				
ZONE	LTR	DESCRIPTION	DATE	APPROVED
	A	SEE DCN NO. 24	6/28/88	QRP
	B	SEE DCN NO. 87	6/21/89	QRP
	C	SEE DCN NO. 98	8/3/89	A.H.B.

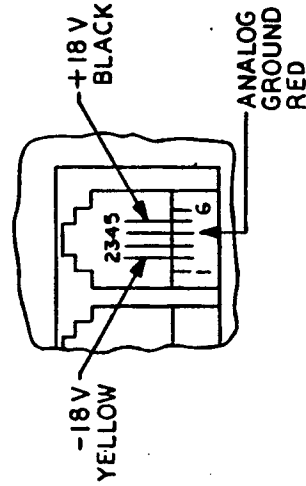
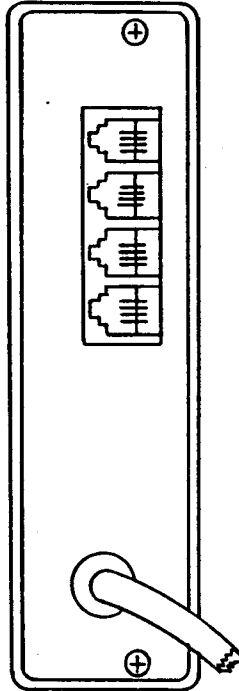
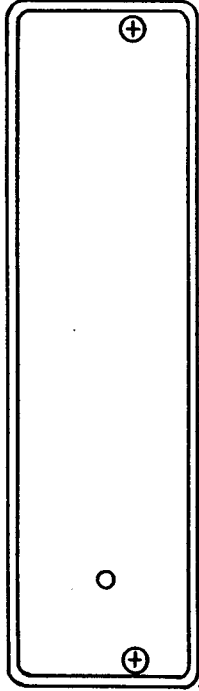
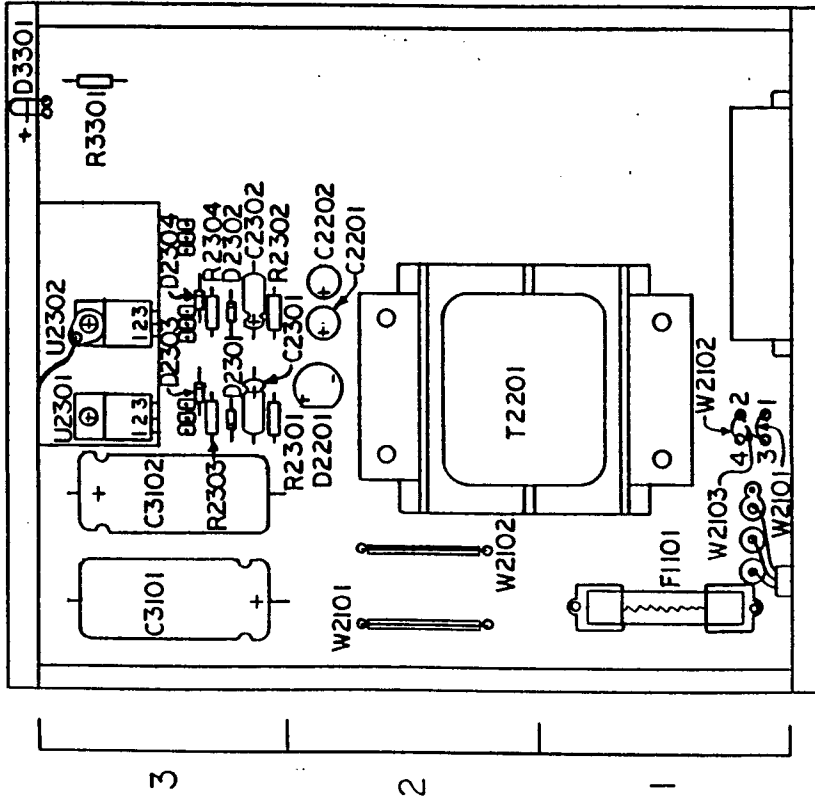

MODULAR POWER CONNECTOR  
 DETAIL

Benchmark Media Systems

PS-11

SCALE	CHECKED BY	DRAWN BY	
DATE	6/21/89	W. J. Penfield	
SIZE	B	COMP. ASS'Y	DRAWING NO. 250039

REVISIONS

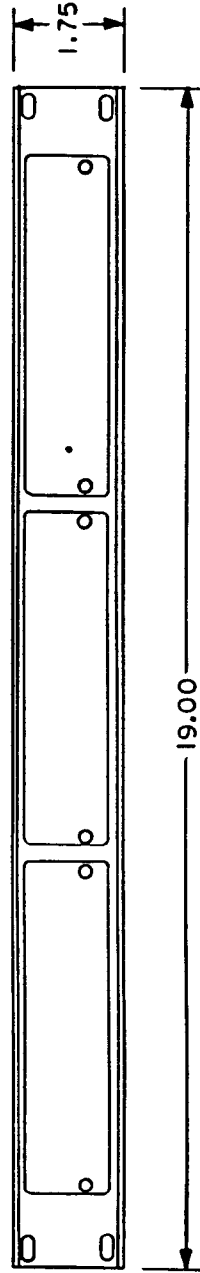
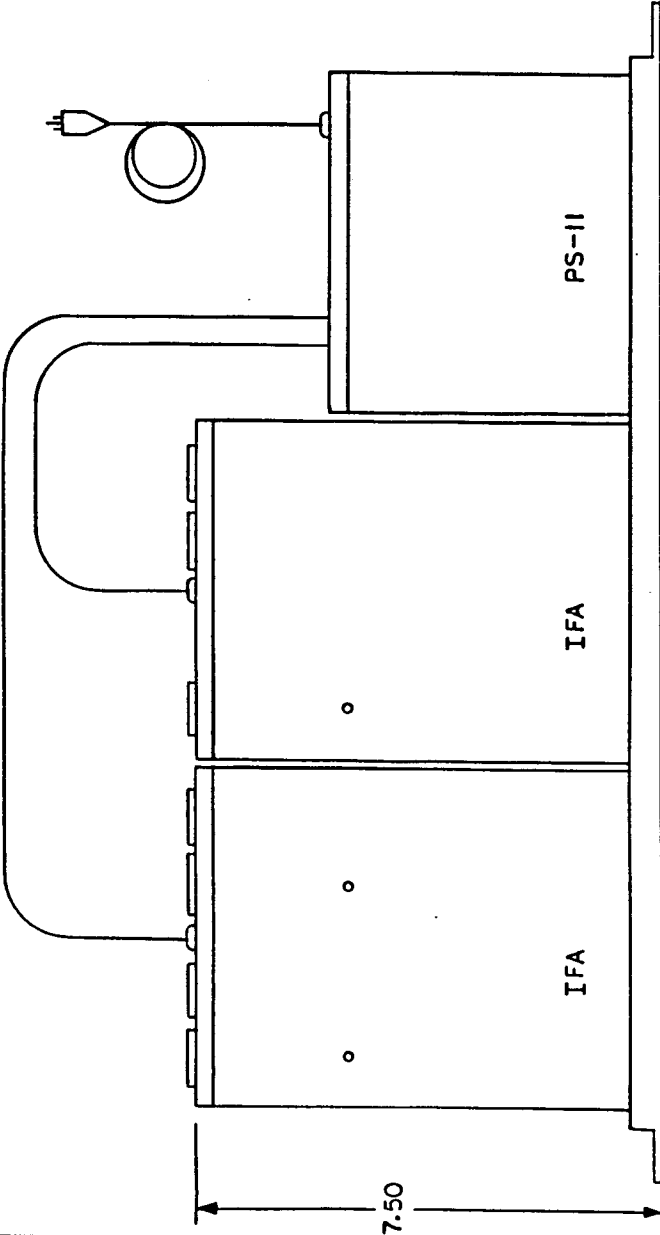

Benchmark Media Systems

RM-1/ IFA RACK MOUNT UNIT

SCALE: CHECKED BY: DRAWN BY: J. PENFIELD

DATE: 5/2/88

SITE: B COMP. ASS'Y. DRAWING NO.: 250043

