

NEX SERIES™ CE12 DUPLEX

Single phase, Duplex, Smart Pump Controller



Installation Instructions and Operation Manual



CONTENTS

1. WARNINGS	1
2. PRODUCT FEATURES	2
3. TECHNICAL SPECIFICATIONS	2
4. INSTALLLATION	3
5. OPERATION	7
6. PANEL PROTECTIONS AND ALARMS	8
7. TROUBLE SHOOTING	9
8. MODBUS	10
9. WARRANTY	12

1. WARNINGS

The following symbols, accompanied by the words: "Danger", "Warning", indicate the potential hazard resulting from failure to observe the associated warning, as specified below:



DANGER RISK OF ELECTRIC SHOCK

Failure to observe the warning may result in electric shock



WARNING

Failure to observe the warning may cause damage to the pump, personal injury and/or damage to property

— **CAUTION:**

Make sure the pumps are fully primed before you start them.

— **CAUTION:**

The control panel must be connected by a qualified electrician in compliance with the electrical regulations in force.

— **CAUTION:**

The electric pump or the motor and the panel must be connected to an efficient grounding system in compliance with the electrical regulations locally in force.

— **CAUTION:**

Ground the unit before carrying out any other operation.

— **CAUTION:**

The electric pump or the motor can start up automatically.

— **CAUTION:**

As a general rule, always disconnect the power supply before proceeding to carry out any operation on the electrical or mechanical components of the unit or system.

— **CAUTION:**

The panel must be installed in sheltered, well-ventilated, non-hazardous environments and must be used at a maximum temperature of +40°C and minimum of -5°C.

— **CAUTION:**

The panel must be handled with care, as falls and knocks can cause damage without any visible external signs. The panel must be stored properly. The external packaging and the separately packed accessories must remain intact, and the whole must be protected from the weather, especially from freezing temperatures.

2. PRODUCT FEATURES

2.1 Introduction

The NEX Series™ CE12 Duplex control panel is designed to control two single phase pump in water and wastewater applications.

It controls the level with 2 ~ 4 float switches. If the level rises to the top float switch the audible/visual alarm is activated.

Typical application includes lift pump chambers, sump pump basins, holding tanks, and other water applications.

2.2 Features

- High level alarm, Pump fault alarm
- Multiple control mode can be selected with a DIP switch
- Float switch fault detection and backup control logic
- Pump fault detection, and automatically switching
- Short circuit protection, pump overload protection, PSE protection
- Pump over-temperature protection
- Weekly test run function

3. TECHNICAL SPECIFICATIONS

Input voltage	Single phase, 110/220/240VAC, 50/60Hz
Rated motor current	2.5A~12.5A
Application Temperature	-5~40°C
Application humidity	50% at 40°C , non-condensing.
Altitude	< 2000m
Enclosure	Polycarbonate enclosure, 254mm(H) X 203mm(W) X 102mm(D)
Protection grade	IP65
Flame retardant rating	UL94 5VA

3.1 Components



1. Current setting switch
2. Operating Mode Selector DIP switch
3. RJ45 port (Modbus RS485)
4. Power on indicator
5. Pump run / Pump fault indicator
6. Float status indicator
7. HOA Switch (Hand-Off-Auto)

8. Circuit breaker pump disconnecting switch
9. Pump Thermoswitch Input Contacts
10. Alarm Relay
11. Pump Fault Relay
12. Red LED Beacon
13. Alarm Horn
14. Alarm Test/Silence Switch

4. INSTALLTION

4.1 Installation the float switches

The NEX Series™ CE12 Duplex control panel designed to operate with 2, 3 or 4 float switches. They activate LEAD & LAG pump stop, LEAD pump START, LAG pump START and high level ALARM functions.



WARNING!

Ensure all power is turned OFF before installing floats in tank. Failure to do so could result in serious shock.

CAUTION!

If the floats are not properly mounted and connected in the correct order, the pumps will not function properly.

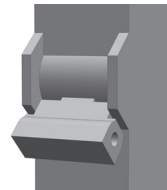

Mount float switches at appropriate levels as illustrated in Figures 1-3.

CAUTION! Be sure that floats have free range of motion without touching each other or other equipment in the basin.

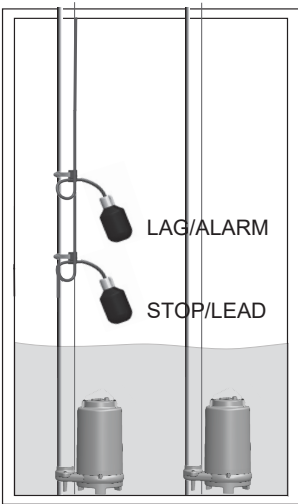

Figure 1 - Two Floats Control

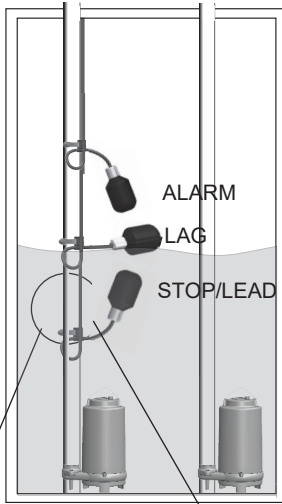

Figure 2 - Three Floats Control

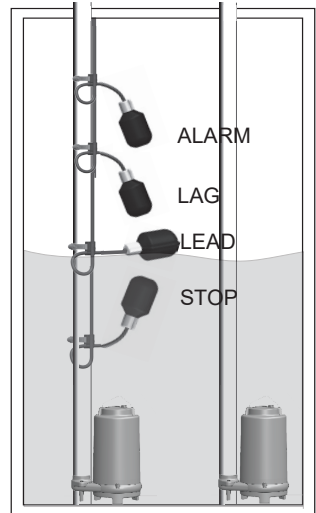
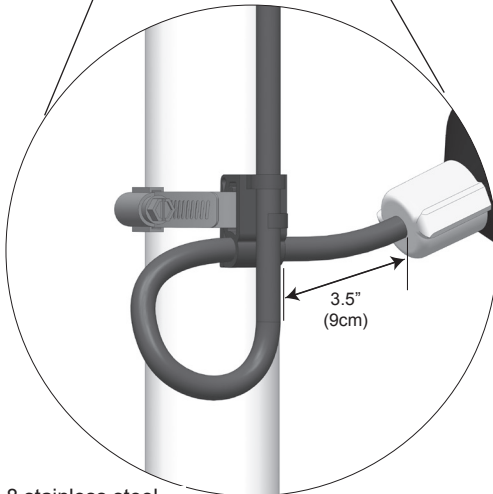

Figure 3 - Four Floats Control

Tighten the clamp.



Note: mounting hose clamp can be ordered from SJE Rhombus factory.

Make sure hose clamp band does not interfere with float operation.

Hose clamp is 18-8 stainless steel. Contact your SJE-Rhombus supplier for replacements.

4.2. Mounting the control panel

NOTE

If the distance to the control panel exceeds the length of the float switch cords or the pump power cord, splicing in a liquid-tight junction box will be required. For outdoor or wet installation, we recommend an SJE-Rhombus, IP66 junction box.

1. Drill and install top fastener using appropriate anchor if necessary.

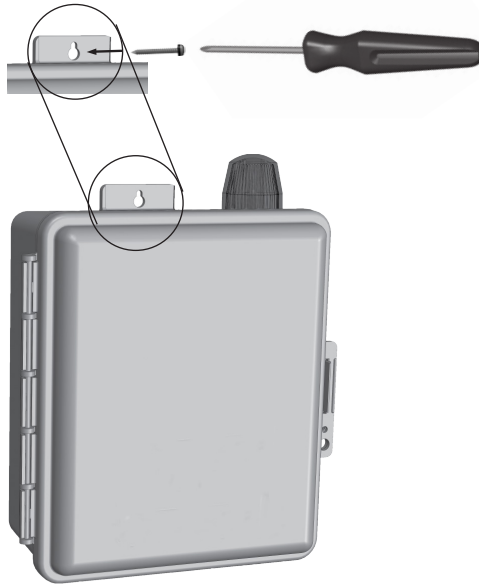

2. Drill and install a bottom fastener using appropriate anchor if necessary.

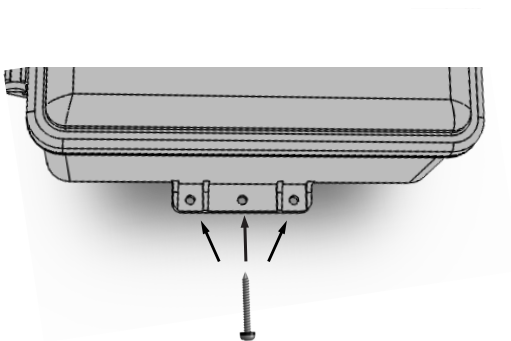

4.3. Wiring the control panel

1. Determine cable gland locations on control panel as shown. Check local codes and wiring label on the inside cover of the panel.

CAUTION!

- * Power must be protected by leakage current protection device (operation current ≤ 30 mA)
- * Be sure the pump power voltage and phase are the same as the pump motor being installed.
- * Use cable gland to prevent moisture or gases from entering the panel.

2. Connect the following wires to the proper terminal positions:
 - pump 1
 - pump 2
 - float switches

See schematic label on inside cover of the control panel for details.

Wiring Diagram

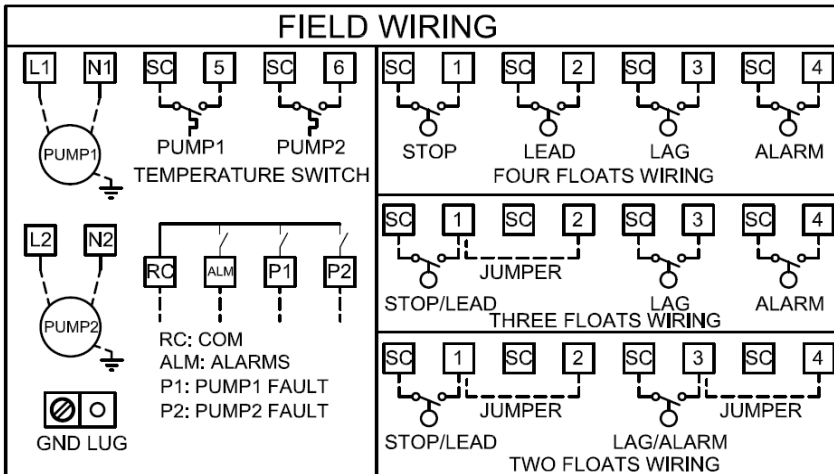

3. Verify correct operation of control panel after installation is complete.

5. OPERATION

The NEX Series® CE12 Duplex control panel operates with 2~4 float switches. Multiple control program available through DIP switch. Through setting up of pump rated current on the current setting switch, the panel will provide the overload protection to the motors.

5.1 Control logic

2 float switches:

When the liquid level rises, the **STOP/LEAD** float close, the Lead pump will turn ON. If the liquid level keep rising, the **LAG/ALARM** float close, the Lag pump will turn on, and the alarm will be activated. When the liquid level decrease, the **LAG/ALARM** float open, the alarm will be stopped. Both two pumps will remain ON until the **STOP/LEAD** float return to the OFF position. The two pumps will be alternatively start by **STOP/LEAD** float.

3 float switches:

When the liquid level rises, the **STOP/LEAD** float close, the Lead pump will turn ON. If the liquid level keep rising, the **LAG** float close, the Lag pump will turn on. Both two pumps will remain ON until the **STOP/LEAD** float return to the OFF position. If the liquid level rises to reach the **ALARM** float, the alarm will be activated. The two pumps will be alternatively start by **STOP/LEAD** float.

4 float switches:

When the liquid level rises and closes the **STOP** float, the panel remains inactive until the **LEAD** float closes. At this point the **LEAD** pump will turn ON. The pump will remain ON until both the **STOP** and **LEAD** floats return to their OFF positions. If the liquid level rises beyond both the "Stop" and **LEAD** floats to reach the **LAG** float, the lag pump will turn ON. Both pumps will remain ON until the **STOP**, **LEAD**, and **LAG** floats return to their OFF positions. If the liquid level rises to reach the **ALARM** float, the alarm will be activated.

5.2 Operation components

Hand-Off-Auto (HOA) Switches

In HAND mode, the pump will turn ON.

In OFF mode, the pump will turn OFF.

In AUTO mode, commands from the float switches turn each pump ON and OFF.

DIP Switch

Position	Function	ON	OFF
1	Overload protection reset method	Auto	Manual
2	PSE protection	Enable	Disable
3	Weekly exerciser	Enable	Disable
4	Float connection	2 or 3 floats	4 floats

Current Setting Switch

Turn the current setting switch, make the arrow point to the rated current of the pump. The overload protection function will be activated.

Circuit Breakers

Each pump circuit has a thermal-magnetic circuit breaker that provides pump disconnect and branch circuit protection.

Alarm Horn/Beacon

When an alarm condition occurs, the red light and horn will be activated. Press the TEST/SILENCE button, the horn will be silenced, but the red light remains ON until the alarm condition release. When the alarm condition is cleared, the alarm horn/beacon will be auto reset.

When no alarm condition occurs, press "TEST/SILENCE" button to test the alarm horn and light.

Weekly Exerciser

Both pumps will be running automatically once a week for 10 seconds to prevent the clog in case of long time out of operation.

6. PANEL PROTECTIONS AND ALARMS

6.1 Pump overload protection/alarm

This alarm appears in the event of a current overload on the pumps. The overload protection is conform to IEC class 10 curve. The pump overload protection can be manually or auto reset. For each pump the current overload alarm allows 3 auto-reset attempts. After three attempts, the panel no longer makes auto-resets, unless the problem is resolved, then the system can be manual reset. To solve this problem, check the pumps, the wiring, and ensure the rated current of the pumps is set correctly. This error may be generated by a blocked pump. (Please refer to Figure 4)

6.2 Pump over-temperature protection/alarm

The panel has terminal blocks that can be connected with pump's thermo switch. In normal status, the thermo switch is closed. When pump's internal temperature increase that the thermo switch open, the panel will send over-temperature alarm notice. The pump will not start until the thermo switch closed. When the pump internal temperature decrease that the thermo switch closed, the pump will restart to work. The pump over-temperature protection can only be reset automatically. (Please refer to Figure 4)

6.3 Pump System Efficiency (PSE)

The PSE monitoring function is the latest in Machine Learning Technology developed specifically for wastewater pumping applications. The proprietary algorithm continuously monitors the tank fill time and discharge times and "learns" what is normal. Should the pump performance drop due to clogging, impeller damage, or changes in head conditions, the PSE function will trigger an alarm. This intelligent solution is not affected by flow variations into the tank and can detect pump Dry Run conditions. The PSE function can be enabled or disabled via the DIP switch on the control panel. The installer can turn the PSE function ON as soon as the system is up and running and system is operating normally. The controller is now able to detect pump system anomalies that are otherwise un-detectable by traditional control panels. Early detection is key to a reliable pumping system and will save time and money by addressing problems before failure. (Please refer to Figure 4)

6.4 Pump fault inspection (Duplex panel)

The panel provides pump fault inspection. When one pump start to operate as the lead pump, the lag pump always operate together, if this situation occur three times consecutively, the system will judge that the lead pump is fail. This pump fault alarm can only be reset manually when the pump fault recovered. And this function can only be applied in duplex panel system. (Please refer to Figure 4)

6.5 Float fault alarm

The system provides float fault detection and backup control program. When float switch fault occurs, the system will change to backup control program of related float switch, and ensure the system continually working properly. When the float fault recovered, the alarm will be reset automatically. This float fault alarm can also be reset manually. (Please refer to Figure 5)

7. TROUBLE SHOOTING

Figure 4 - Pump Error List

Pump Errors	Pump Indicator	Beacon	Alarm Horn	Possible Cause of Failure	Solutions
Pump overload	Flashing 1x	Flashing 1x	ON	1. Pump overload current setting incorrect. 2. Pump clogged.	1. Check the overload current setting, make sure it is in line with the pump rated current. 2. Check the pump inlet, pump impeller, bearing, etc.
PSE protection	Flashing 2x	Flashing 1x	ON	1. Pump fault 2. Float fault.	1. Check the pump status 2. Check the float switch status
Pump over-temperature	Flashing 3x	Flashing 1x	ON	1. Pump clog, heat dissipation is not very good. 2. Water temperature too high, etc.	1. Check if there is any stuff blocked in the pump. 2. Check the water tank's temperature.
Pump fault	Flashing 4x	Flashing 1x	ON	Pump fault	Check the faulty pump and the pipes

Figure 5 - Float Switch Error List

Float Errors	Float Indicator	Beacon	Alarm Horn	Possible Cause of Failure	Solutions
STOP Float fault	STOP Float Flashing 1x	Flashing 2x	ON	1. Float fail. 2. Float wiring issue. 3. Float stuck.	1. Check if the float is fault. 2. Check the float wiring. Whether the cable is damaged. 3. Check if the float is stuck
LEAD Float fault	LEAD Float Flashing 1x	Flashing 2x	ON		
LAG Float fault	LAG Float Flashing 1x	Flashing 2x	ON		
STOP / LEAD Float fault	STOP / LEAD Float Flashing 1x	Flashing 2x	ON		

Figure 6 - Other Error List

Other Errors	Possible Cause of Failure	Solutions
Power indicator is not on	1. Power supply fail. 2. Power supply error	1. Check if the power voltage is correct, 2. Check if the power is on.
Pump can not work automatically	1. Power supply fail. 2. HOA switch is not in AUTO mode. 3. Pump fault. 4. Float switch fault	1. Check the power supply. 2. Check if HOA switch is in AUTO mode. 3. Check if any pump fail occurs 4. Check the float switch status.
Pump can not work manually	1. Power supply fail. 2. Pump wiring has problem. 3. Pump fault.	1. Check the power supply. 2. Check if any pump fail occurs 3. Check the float switch status.

8. Modbus

The NEX Series™ CE12 panel is equipped with Modbus RTU supporting using the “D+” and “D-” RS-485 terminals of RJ45 port.

Default setting

Band Rate:	9600 band (Can be set to 1200,2400,4800,19200,38400)	Parity:	None (fixed)
Data Bits:	8 bits (fixed)	Node Address:	1 (Can be set from 1-247)
Stop Bits:	1 bit (fixed)		

RS485 port connection:	<ul style="list-style-type: none"> • RJ45-5: D+ (A+) • RJ45-4: D- (B-)
------------------------	--

CE12 CONTROL PANEL MODBUS REGISTER LIST

Access Type	Register Address Number	Bit	Description	Unit Of Measure (Other Notes)
Read	40001		Device Name	0x0A12: CE12 Panel
Read/Write	40003		Device address	Range 1-247; Default Setting: 1
Read/Write	40004		Baud rate	1200,2400,4800,9600,19200,38400; Default Setting : 9600
Read	40031	0	Stop Float Status (4 Floats Mode); Stop/Lead Float Status (3/2 Floats Mode)	1: ON; 0: OFF
		1	Lead Float Status (4 Floats Mode)	1: ON; 0: OFF
		2	Lag Float Status (4/3 Floats Mode); Lag/Alarm Float Status (2 Floats Mode)	1: ON; 0: OFF
		3	Alarm Float Status (4/3 Floats Mode)	1: ON; 0: OFF
		4	Pumps Overload Alarm / Alarm contact Reset Mode	DIP Switch-1: 1(ON): Auto Reset; 0(OFF): Manual Reset
		5	PSE Protection	DIP Switch-2: 1(ON): Enable; 0(OFF): Disable
		6	Pumps Weekly Exercise	DIP Switch-3: 1(ON): Enable; 0(OFF): Disable
		7	Float Mode	DIP Switch-4: 1(ON): 2/3 Floats; 0(OFF): 4 Floats
Read	40032		Float Fail Indicator	0XXXX1: Stop Float Fail (4 or 3 Floats Mode)
				0XXXX2: Lead Float Fail (4 Floats Mode)
				0XXXX3: Lag Float Fail (4 or 3 Floats Mode)
				0XXXX4: Stop/Lead Float Fail (3 or 2 Floats Mode)

8. Modbus

Read	40036		Pump Current Setting	Actual Value = Readout Value*0.01
Read	40037		Alarm Information	
Write	40061		Fail Reset	0x5A5A
Write	40062		Silence	0x5A5A
Write	40063		Alarm Relay Reset	0x5A5A
Read	41101	3	Pump1 in Auto Mode	1: Pump1 Operation mode selected to Auto
		4	Pump1 Overload Protection	1: Pump1 Overload Protected
		5	Pump1 PSE Protection	1: Pump1 PSE Protected
		6	Pump1 Over Temperature Protection	1: Pump1 Over Temperature Protected
		7	Pump1 System Fault	1: Pump1 System Fault
Read	41102		Pump1 Running Cycle Counter (High)	Pump1 Running Cycle Counter; (32-bit value)
Read	41103		Pump1 Running Cycle Counter (Low)	
Read	41104		Pump1 Running Timer Meter (High)	Pump1 Running Time Meter; (32-bit value)
Read	41105		Pump1 Running Timer Meter (Low)	
Read	41106		Pump1 Running Current	Actual Value = Readout Value*0.1
Read	41201	3	Pump2 In Auto Mode	1: Pump2 Operation mode selected to Auto
		4	Pump2 Overload Protection	1: Pump2 Overload Protected
		5	Pump2 PSE Protection	1: Pump2 PSE Protected
		6	Pump2 Over Temperature Protection	1: Pump2 Over Temperature Protected
		7	Pump2 System Fault	1: Pump2 System Fault
Read	41202		Pump2 Running Cycle Counter (High)	Pump2 Running Cycle Counter; (32-bit value)
Read	41203		Pump2 Running Cycle Counter (Low)	
Read	41204		Pump2 Running Time Meter (High)	Pump2 Running Time Meter; (32-bit value)
Read	41205		Pump2 Running Time Meter (Low)	
Read	41206		Pump2 Running Current	Actual Value = Readout Value * 0.1

The Register 40037 is for showing fails and alarms. Below are Float Fail, Pump Fail, High Level Alarm Codes, this is for indicator the alarm and fails happened. The fails and alarms may occurred at same time, please see the code in the following table for details

Float Fail & Pump Fail & High Level Alarm Codes

Stop Float Fail :	0xXXX1	Pump1 System Fail :	0xXX4X
Lead Float Fail :	0xXXX2	Pump2 Overload :	0xX1XX
Lag Float Fail :	0xXXX3	Pump2 PSE protection :	0xX2XX
Stop/Lead Float Fail :	0xXXX4	Pump2 Over Temperature :	0xX3XX
Pump1 Overload :	0xXX1X	Pump2 System Fail :	0xX4XX
Pump1 PSE protection :	0xXX2X	High Level Alarm :	Bit12 : 1
Pump1 Over Temperature :	0xXX3X	Fail Alarm :	Bit15 : 1

Reset Modbus Parameters To Default Setting:

Turn off the panel power, set the pump running mode to **OFF**, push and holding the **TEST/SILENCE** button then turn on the power. When see all floats lights **ON** together that means reset work is done, please release **TEST/SILENCE** button.

Please do not forget set the pump running **HOA** switch to **AUTO** position if you want to pump automatic **ON/OFF** through float signal controlled.

9. SJE-RHOMBUS® TWO-YEAR LIMITED WARRANTY

SJE-RHOMBUS® warrants to the original consumer that this product shall be free of manufacturing defects for two years after the date of consumer purchase. During that time period and subject to the conditions set forth below, **SJE-RHOMBUS®** will repair or replace, for the original consumer, any component which proves to be defective due to defective materials or workmanship of **SJE-RHOMBUS®**.

ELECTRICAL WIRING AND SERVICING OF THIS PRODUCT MUST BE PERFORMED BY A LICENSED ELECTRICIAN.

THIS WARRANTY DOES NOT APPLY:(A) to damage due to lightning or conditions beyond the control of **SJE-RHOMBUS®**; (B) to defects or malfunctions resulting from failure to properly install, operate or maintain the unit in accordance with printed instructions provided; (C) to failures resulting from abuse, misuse, accident, or negligence; (D) to units which are not installed in accordance with applicable local codes, ordinances, or accepted trade practices, and (E) to units repaired and/or modified without prior authorization from **SJE-RHOMBUS®**.

TO OBTAIN WARRANTY SERVICE: The consumer shall assume all responsibility and expense for removal, reinstallation, and freight. Any item to be repaired or replaced under this warranty must be returned to **SJE-RHOMBUS®**, or such place as designated by **SJE-RHOMBUS®**.

ANY IMPLIED WARRANTIES OF MERCHANTABILITY OR FITNESS ARE LIMITED TO DURATION OF THIS WRITTEN WARRANTY. SJE-RHOMBUS® SHALL NOT, IN ANY MANNER, BE LIABLE FOR ANY INCIDENTAL OR CONSEQUENTIAL DAMAGES AS A RESULT OF A BREACH OF THIS WRITTEN WARRANTY OR ANY IMPLIED WARRANTY.

The device must not be operated beyond the limit values for the operating voltage, rated mains frequency, ambient temperature and switching capacity specified in the product literature. Make sure that operation is in accordance with the instructions laid down in this manual or in the contract documentation.



This operating manual contains important information which must be observed when installing, operating and maintaining the device. For this reason, it must be read and understood by the installing personnel and the responsible technical staff/operators before the device is installed and commissioned. The manual must always be kept available at the place of installation of the device for future reference. In addition to the general safety information laid down in this chapter on "Safety", the safety information provided in other sections must also be observed.



SJE-Rhombus (Suzhou) Co., Ltd.

Unit B2-6, District A, Weiting Industrial Workplace, No.
9 Weixin Road, Weiting Town, Suzhou Industrial Park,
Suzhou, Jiangsu Province, 215122, China

Phone: (86) 512 6507 2880

Fax: (86) 512 6507 2881

E-mail: sjesales@sjerhombus.cn

www.sjerhombus.cn