

StrobeGuard™ SS-122/125

High Intensity White Strobe Lighting System

FAA Type: L-856 High Intensity Lighting

ICAO Type: Type A High Intensity Obstacle Light

ETL Certified:

FAA Advisory Circular AC 150/5345-43E

Compliant to:

Canadian Aviation Regulation 621.19

ICAO Annex 14, MIL-C-7989, DGAC of Mexico

SS1-125 Obstruction Strobe Light:

The StrobeGuard SS-125 is a single enclosure obstruction light designed to meet or exceed the requirements of Advisory Circular 150/5345-43E. The enclosures are fabricated from 304L stainless steel. All plug-in printed circuit boards are protected with a coating which meets the physical and electrical requirements of MIL-I-46058B. The SS-125 is supplied with a lightning arrestor capable of withstanding repeated 10,000 ampere current surges. Operated with the SS-122 Controller, the system is completely self-activating for monitoring and identifying any malfunctioning light and is equipped to initiate a remote alarm. The number of SS-125 obstruction lights used on an installation depends upon the type of obstruction and its height.

SS-122 Controller:

StrobeGuard Controllers contain the flash interval and timing circuits, intensity selection controls, and monitoring receivers with status indicators required to operate the SS-125 strobe light. The controller is of modular construction with solid state circuitry for long life and ease of maintenance. StrobeGuard controllers are designed to operate up to 32 obstruction lights at distances up to 4700 feet. Each controller is equipped with the necessary manually operated controls to test all modes of operation. Digital monitor lamps are provided and illuminate when a flashhead or power supply is not operating as required. Each monitor lamp is operated in a coded mode indicating the location of the flashhead/power supply which is malfunctioning.

SS-124 Ambient Sensor:

The SS-124 Light Sensor continuously monitors the ambient lighting conditions and inputs to the StrobeGuard controller the necessary information to automatically control the switching of daytime, twilight and nighttime modes of operation. The SS-124 is easy to install with the built-in mounting holes.

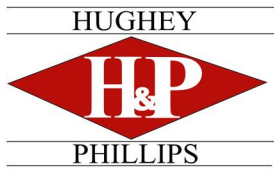

HUGHEY & PHILLIPS

Specifications:

Photometric	Day	200,000 candela ± 25%
	Twilight	20,000 candela ± 25%
	Night	2,000 candela ± 25%
	Beam Spread	3° Vertical minimum
	Horizontal Coverage	120° coverage
	Cut off Angle	<3% light output at -10° Vertical
	Flash Rate	40 Flashes per Minute (FPM)
Environmental	Temperature	-55° C to +55° C -67° F to + 130° F
	Humidity	95% relative humidity
	Will withstand exposure to:	Wind-blown rain from any angle
		Salt-laden atmosphere Wind speed of 240kph (150mph)
Mechanical	Weight, Controller	19.5kg (43 lbs)
	Dimensions, Controller	22" H x 17" W x 7" D
	Weight, Flashhead	37kg (82 lbs)
	Dimensions, Flashhead	15" H x 19" W x 11" D
Electrical	Enclosure	304 Stainless Steel, NEMA 4X
	Input Voltages	120, 208, 240, 277, 380, 480V
	Input Frequency	50 or 60 Hz
	Power Consumption	0.55kVA per flashhead

Flashhead Mounting Details:

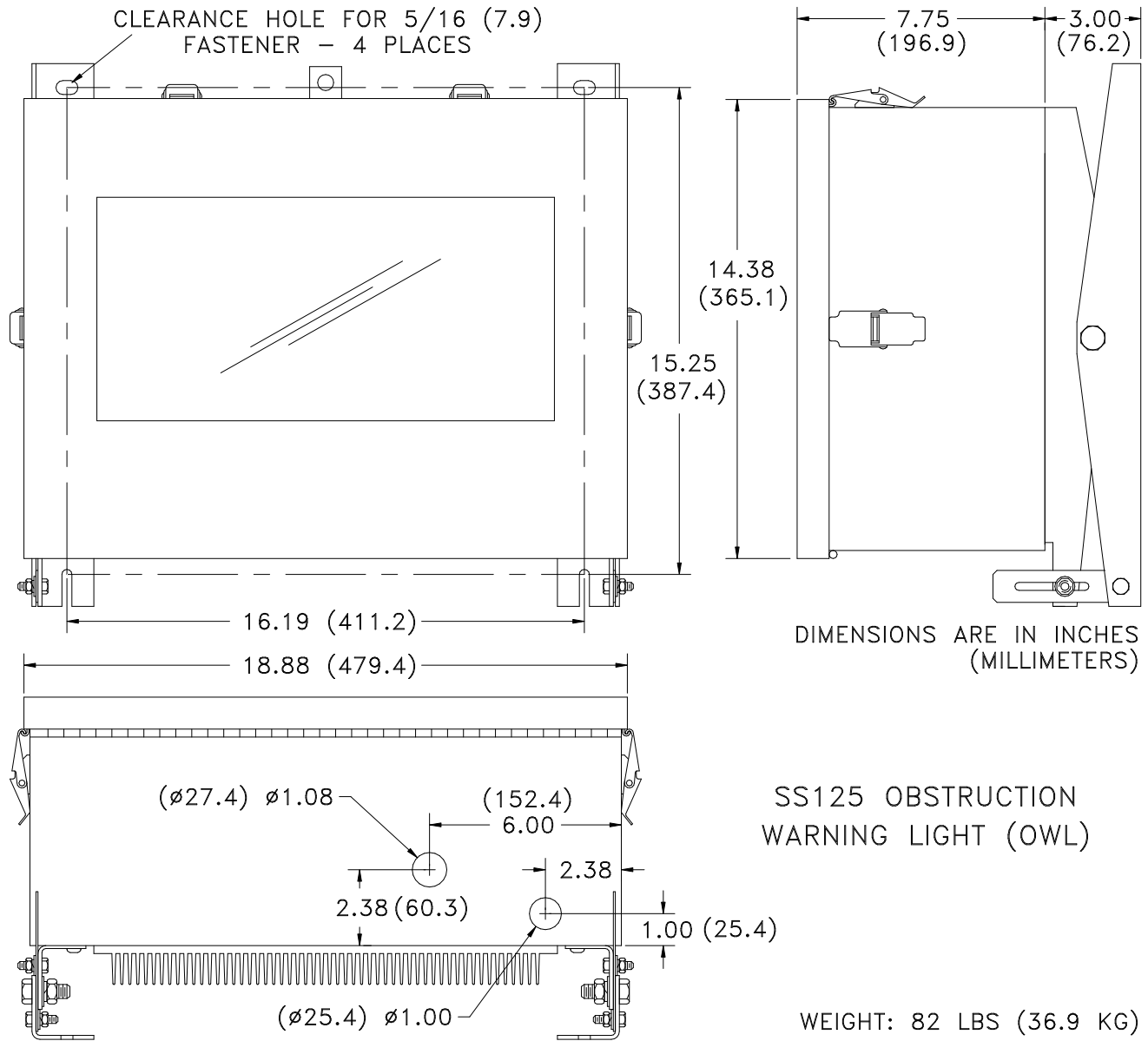

Controller Mounting Details:

SS-122 CONTROLLER

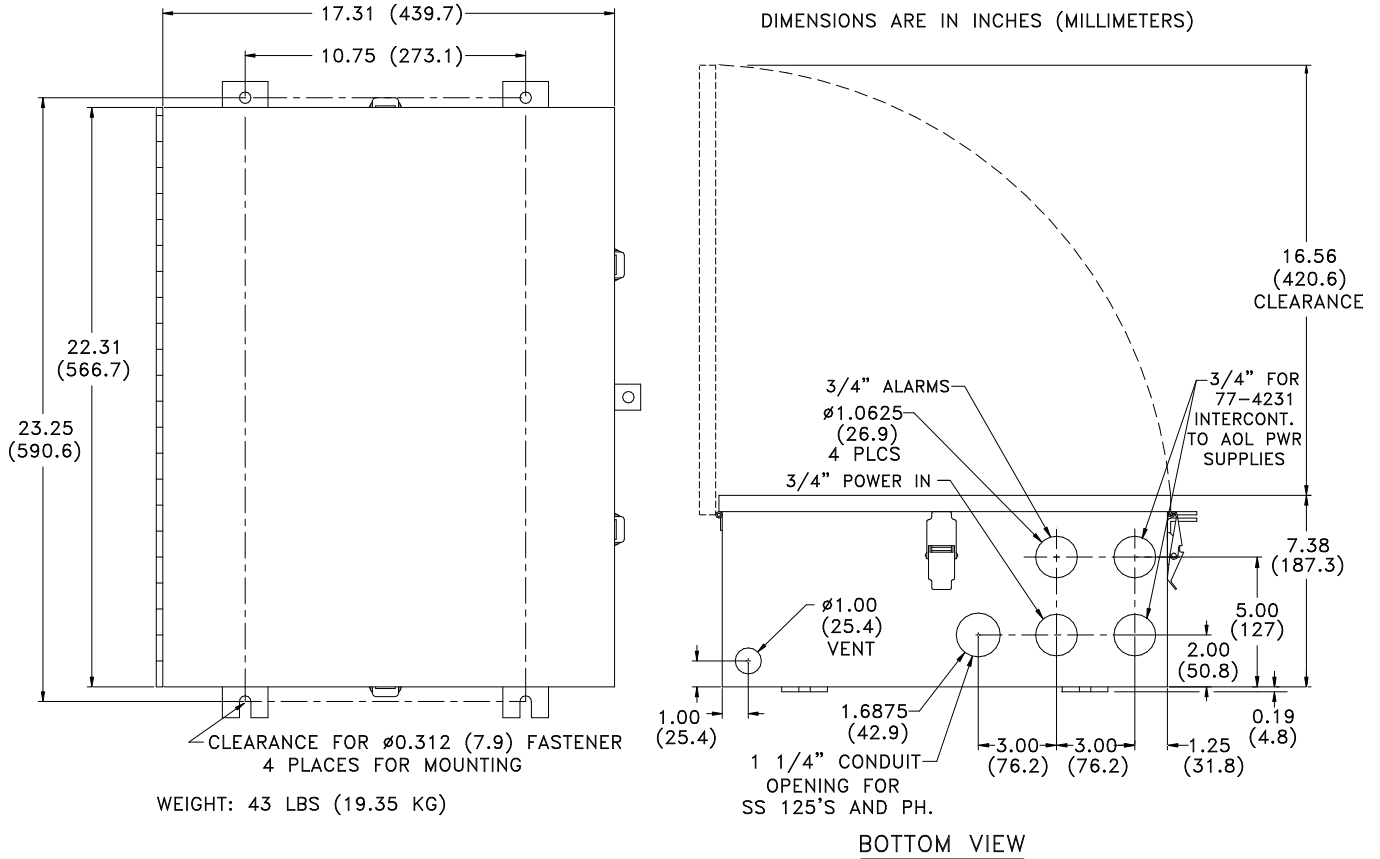

SS124 AMBIENT LIGHT SENSOR

