



**EXPRESS GLASS WAREHOUSE**

**Express Glass Warehouse**  
**51-55 Fowler Road,**  
**Hainault, Essex**  
**IG6 3UT**

Tel: +44 (0)20 8500 1188  
 Fax: +44 (0)20 8500 1010  
 Email: info@egw.co.uk  
 Website: www.egw.co.uk

Copyright (C) - October 2020, All Rights Reserved

**TYPICAL GLAZING  
 DETAIL ON CHANNEL**

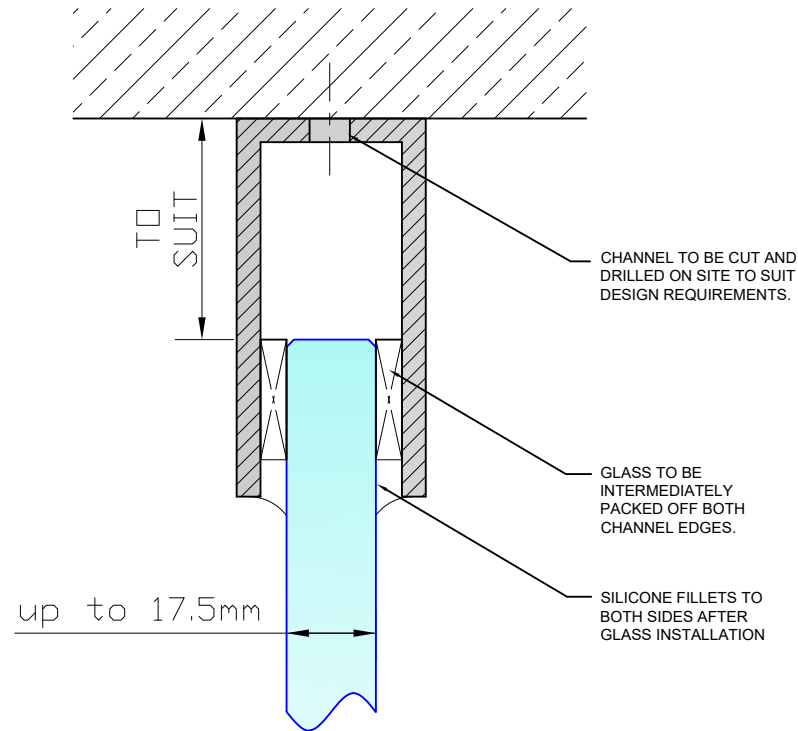

**NOTES/SPECIFICATION:**

GLAZING CHANNEL SUPPLIED IN SILVER ANODISED EXTRUDED ALUMINIUM WITH PLASTIC GLAZING PACKERS

GLAZING CHANNEL SUITABLE FOR UP TO 17.5mm GLASS PANES REQUIRES CUTTING AND DRILLING TO SUIT DESIGN REQUIREMENTS ON SITE

(NOTE CUSTOMER TO PROVIDE REQUIRED FIXINGS)

CAN BE UTILISED IN SHUFFLE GLAZED APPLICATIONS, IN CONJUNCTION WITH OUR CHANNEL:-

SH/GGA/C01 - (25mm(h) GLAZING CHANNEL)

**END VIEW  
 ON CHANNEL**

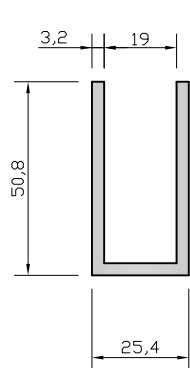

**SIDE VIEW  
 ON CHANNEL**

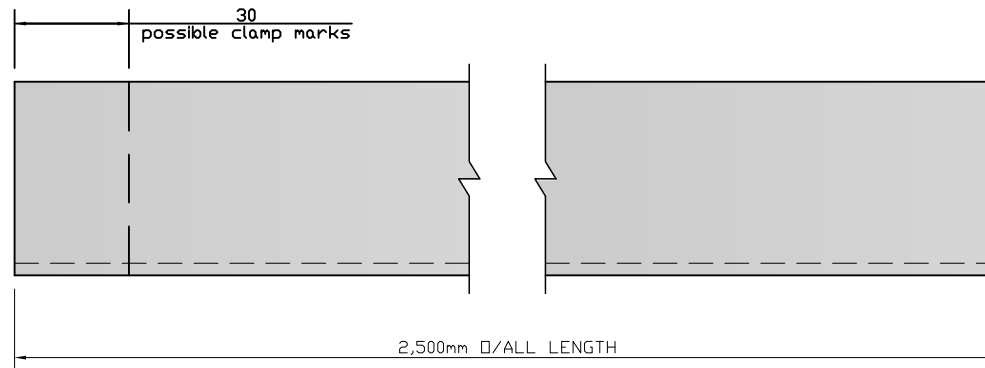

<b>PRODUCT REF:</b>	<b>SH/GGA/C03</b>
<b>DESCRIPTION:</b>	DIMENSIONED ELEVATIONS AND PRODUCT DETAILS
<b>DRAWING REF:</b>	<b>SH/GGA/C03 - 001E</b>