

PLAN VIEW  
ON FITTING

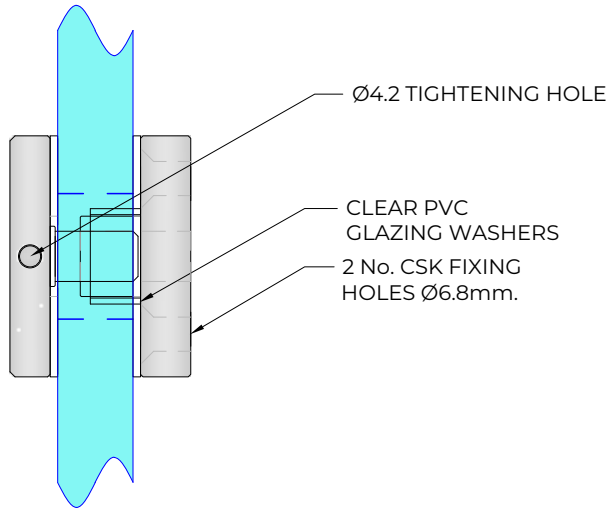

REQUIRED  
GLASS PREP

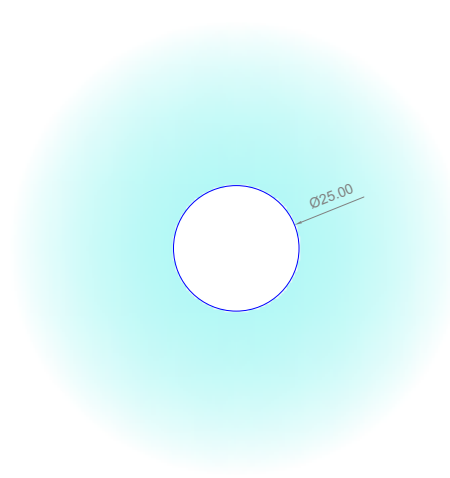

(Ø25mm HOLE - POSITIONING TO  
SUIT APPLICATION / DESIGN  
REQUIREMENTS)

SIDE VIEW  
ON FITTING

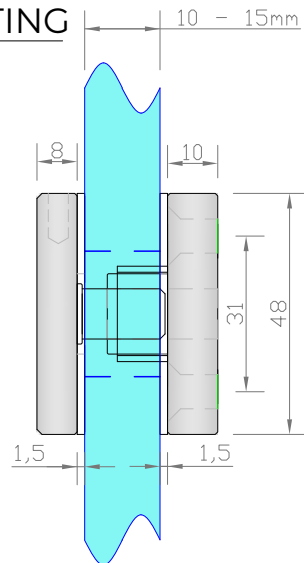

FRONT VIEW  
ON FITTING

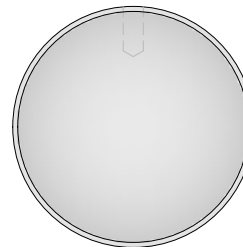

NOTE - RADIAL FINISHING LOCATION OF  
TIGHTENING HOLE WILL VARY BETWEEN  
FITTINGS.



**Express Glass Warehouse**  
51-55 Fowler Road,  
Hainault, Essex  
IG6 3UT

Tel: +44 (0)20 8500 1188  
Fax: +44 (0)20 8500 1010  
Email: info@egw.co.uk  
Website: www.egw.co.uk

Copyright (C) - October 2020, All Rights Reserved

**NOTES/SPECIFICATION:**

ALL FITTING COMPONENTS IN GRADE 316 MACHINED STAINLESS STEEL FINISH.

PRODUCT SUITABLE FOR 10mm TO 15mm TOUGHENED GLASS PANES.

FITTING SUPPLIED COMPLETE WITH:-

- 1) 4 No. x 1.5mm CLEAR PVC GLAZING WASHERS.
- 2) 1 No. GLASS FIXING TUBULAR WASHER.

NOTE - PRODUCT PRE-DRILLED WITH 2 No. Ø6.8 COUNTERSUNK HOLES. CLIENT TO PROVIDE FIXINGS TO SUIT INTERFACE DETAILING AND STRUCTURAL REQUIREMENTS (HOLE DIA. SUITS No. 12 CSK WOODSCREWS AND M6 CSK MACHINE SCREWS).

THREADED ALL THE WAY THROUGH SO STUD CAN BE ATTACHED AND BOLTED TO FRAMEWORK.

LOCK TITE (SUPPLIED BY OTHERS) CAN BE USED ON THREADED CONNECTION TO PREVENT REMOVAL.

**PRODUCT REF: SH/ATB/GF03**

**DESCRIPTION:** DIMENSIONED ELEVATIONS AND  
REQUIRED GLASS PREP DETAIL  
\*  
AB - 22/01/19

**DRAWING REF: SH/ATB/GF03 - 001E**



EXPRESS GLASS WAREHOUSE

Express Glass Warehouse  
51-55 Fowler Road,  
Hainault, Essex  
IG6 3UT

Tel: +44 (0)20 8500 1188  
Fax: +44 (0)20 8500 1010  
Email: info@egw.co.uk  
Website: www.egw.co.uk

Copyright (C) - October 2020, All Rights Reserved

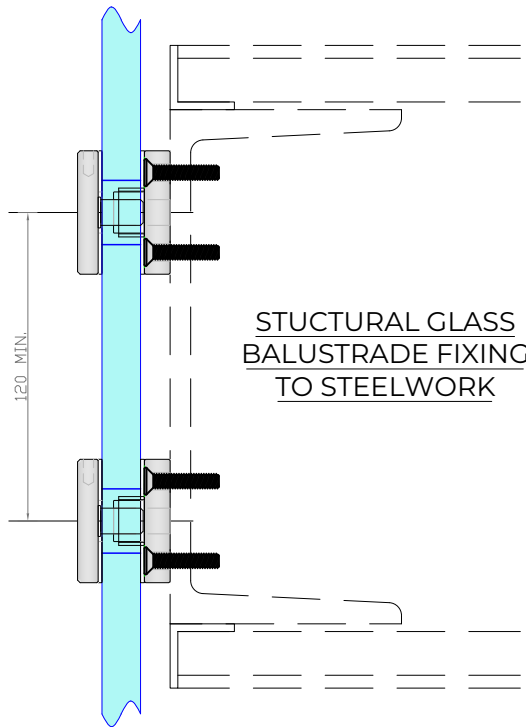

STUCTURAL GLASS  
BALUSTRADE FIXING  
TO STEELWORK

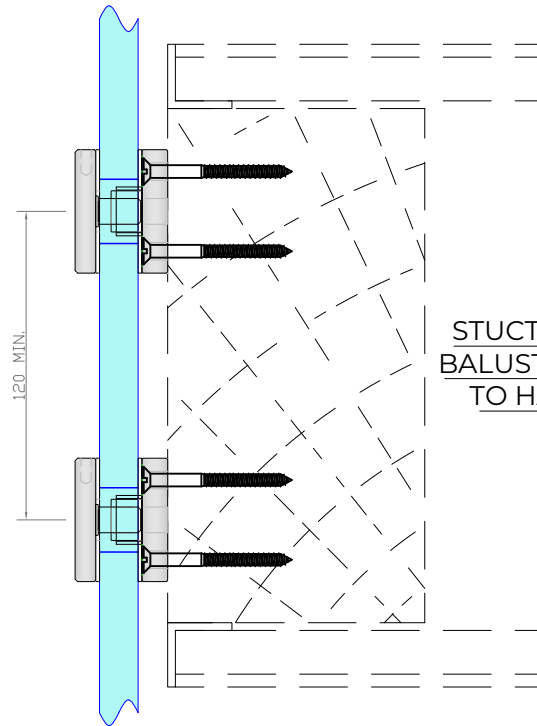

STUCTURAL GLASS  
BALUSTRADE FIXING  
TO HARDWOOD

TYPICAL GLASS  
BALUSTRADE FIXING  
TO INTERMEDIATE POSTS

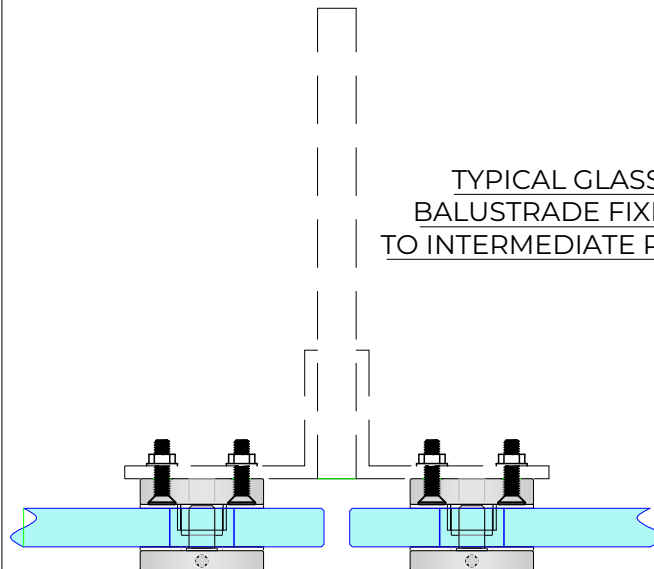

**NOTES/SPECIFICATION:**

ALL FITTING COMPONENTS IN GRADE 316 MACHINED STAINLESS STEEL FINISH.

PRODUCT SUITABLE FOR 10mm TO 15mm TOUGHENED GLASS PANES.

FITTING SUPPLIED COMPLETE WITH:-

- 1) 4 No. x 1.5mm CLEAR PVC GLAZING WASHERS.
- 2) 1 No. GLASS FIXING TUBULAR WASHER.

NOTE - PRODUCT PRE-DRILLED WITH 2 No. Ø6.8 COUNTERSUNK HOLES. CLIENT TO PROVIDE FIXINGS TO SUIT INTERFACE DETAILING AND STRUCTURAL REQUIREMENTS (HOLE DIA. SUITS No. 12 CSK WOODSCREWS AND M6 CSK MACHINE SCREWS).

THREADED ALL THE WAY THROUGH SO STUD CAN BE ATTACHED AND BOLTED TO FRAMEWORK.

LOCK TITE (SUPPLIED BY OTHERS) CAN BE USED ON THREADED CONNECTION TO PREVENT REMOVAL.

**PRODUCT REF:** SH/ATB/GF03

**DESCRIPTION:** EXAMPLES OF TYPICAL FIXING DETAILS  
\*  
AB - 22/01/19

**DRAWING REF:** SH/ATB/GF03 - 002E