

*PLEASE READ THESE INSTRUCTIONS COMPLETELY BEFORE ATTEMPTING TO ASSEMBLE YOUR NEW FOUNTAIN

CONTENTS:

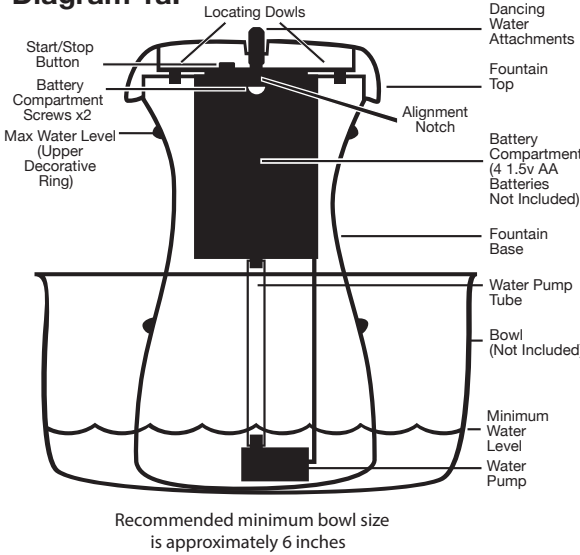

Diagram 1a:



STEP 1

INSTALLING BATTERIES:

1. Lift Fountain Top with Battery Compartment & Water Pump out of the Fountain Base (Figure 5). Disconnect the Water Tube from the Battery Compartment.
2. Unscrew (counter clockwise) the Battery Compartment Screws and open cover (Figure 1a, 1b).
3. Orient the Battery Compartment with locating dowel on top. (See Arrow Figure 2a& 2b).
4. Insert 2-1.5v AA Batteries with the (+) side facing up in Battery Compartment and 2 AA Batteries with the (-) facing up in Battery Compartment (Figure 2a).
5. Reinstall the Fountain Top by aligning the locating dowel in the Battery Compartment and Fountain Top. Set the Battery Cover down onto the Battery Compartment ensuring the dowel sets into the alignment hole. Tighten the Battery Cover Screw by turning clockwise. **NOTE: You may need to apply pressure to the Battery Compartment Screws while tightening for the threads to catch.**

CHANGING BATTERIES:

1. Remove any Dancing Water Attachment, lift Battery Compartment and Water Pump out of the Fountain (Figure 5), ensure Battery Compartment and Water Pump are completely dry before opening Battery Compartment. It is important that no water enters the Battery Compartment.
2. See Installing Batteries Section above on how to reinstall batteries and reassemble.
3. Set the Battery Compartment and Water Pump back into the Fountain (Figure 6).

STEP 2

Assembly

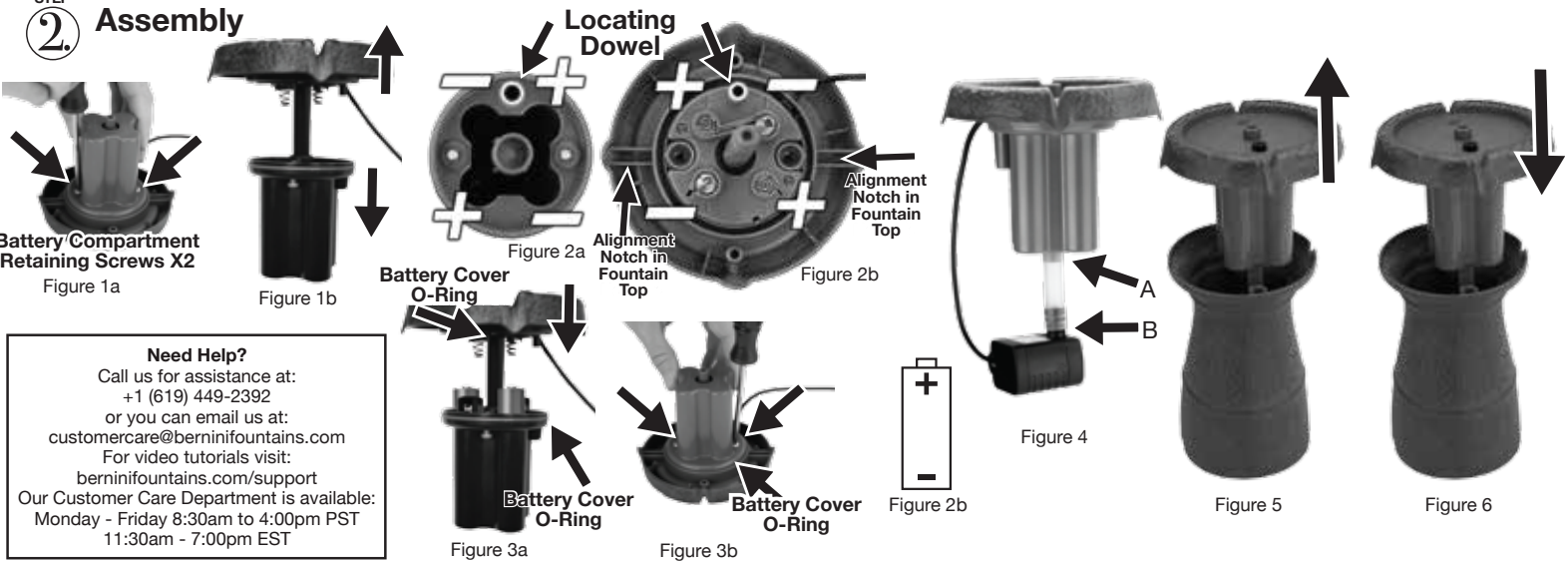

1. Take the Fountain Top/Battery Compartment and Water Pump, connect one side of the Water Tube to the Water Pump and the other end to the bottom side of the Battery Compartment (A & B of Figure 4).
2. Find a suitable bowl and place it on a flat, level surface and place the Fountain Base, without the Fountain Top with Battery Compartment and Water Pump, into the center of the bowl.
3. Lower the Fountain Top with Battery Compartment and Water Pump into the Fountain Base. There are two locating dowels and two alignment notches that help you align the Fountain Top to the Fountain Base. Fit these into place and press to Fountain Top and Base together to secure (Figure 6).
4. Fill bowl with water, water level should cover the Water Pump (Diagram 1a).

STEP 3

OPERATING YOUR FOUNTAIN TOWER:

Turn On Fountain: When the Fountain is off, press the button to turn on (Figure 7a & b). The fountain will run for one hour and automatically turn off.

Stop Fountain: To stop the Fountain press the button to turn off.

DANCING WATER ATTACHMENT (OPTIONAL): When Fountain is not running, attach the Dancing Water Attachment and attach to the outlet in the middle of the Fountain Tower (Figure 8a, 8b and 8c). To prevent overspray, use a larger bowl.

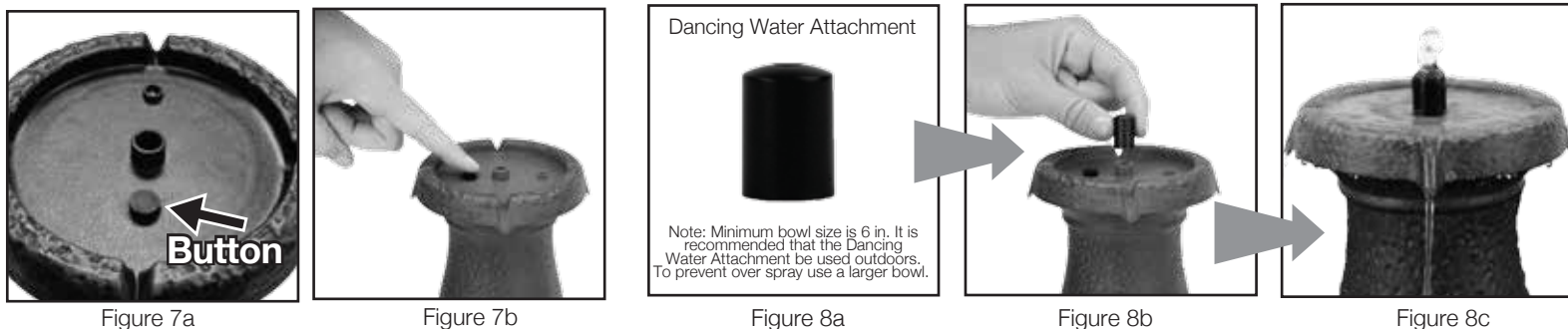

STEP 4 Troubleshooting

Troubleshooting Guide

PRIMING THE WATER PUMP

If you find the Water Pump is running, but water is not flowing from your Fountain, you can try priming the Water Pump:
Turn off Fountain, grab both sides of the Fountain and quickly shake your Fountain for ten seconds. This is to dislodge any air bubbles that may be caught in your Water Pump. Press the button to turn on your Fountain. Water should be flowing from the top of your Fountain. If water is not flowing, press and hold button for over 2 seconds again to turn off your Fountain, and repeat the step above.

WATER PUMP CONNECTION

If your Water Pump becomes disconnected from the Water Tube inside of the Fountain or if the Water Tube gets disconnected from the Battery Compartment, go to the Assembly Section to reconnect the Water Pump.

PROBLEM	SOLUTION
Water Not Flowing	Check batteries are installed correctly: See Installing Batteries Section.
	Check that batteries are new and good condition: See Installing Batteries Section.
	Pump is on but no water flow: Check water level.
	Pump is on but no water flow: Check pump is free of debris, kinks or obstructions. See Care And Maintenance Section.
	Pump is on but no water flow: Check tube is connected properly. See Assembly Section.
Low Water Flow	Check that batteries are new and good condition: See Installing Batteries Section.
	Pump is on but low water flow: Check pump is free of debris, kinks or obstructions. See Care And Maintenance Section. Pump is on but low water flow: Check water level. Air in pump: See Priming The Water Pump Section.
Loud Sound	Loud sound and weak flow: Air in pump: See Priming The Water Pump Section.
	Loud sound and weak flow: Check pump is free of debris, kinks or obstructions. See Care And Maintenance Section.
Suddenly Stops	Pump suddenly stops: Check pump is free of debris, kinks or obstructions. See Care And Maintenance Section.

STEP 5 Care and Maintenance

CLEANING YOUR FOUNTAIN

In order to keep your Fountain in tip-top shape and for a prolonged life, it is best if your Fountain and the bowl or water container that the Fountain is placed in are cleaned periodically. To clean your fountain, drain of all water and disassemble. Use a mild soap and a soft cloth to clean the parts of your Fountain.

COLD STORAGE

Turn power off, remove from container, clean and dry the Fountain of all water. Remove the batteries for long term storage and bring it indoors. (Now is a great time to clean the pump to remove any debris that may have accumulated throughout the year).

CLEANING THE WATER PUMP'S PARTS

The impeller inside of the Water Pump is what pushes water up through your Fountain, allowing you to enjoy the soothing sounds and wonderful sights of your Fountain. After long periods of usage, this part will need to be cleaned to make sure your Fountain runs optimally.

Step 1: Remove the front panel of the Water Pump by grabbing the sides of the front panel and pulling it off the unit.

Step 2: Remove the impeller chamber cover. This is tightly fitted but will come off.

Step 3: Remove the impeller from its chamber.

Step 4: Rinse the impeller until all debris has been removed.

Step 5: Re assemble in reverse order.

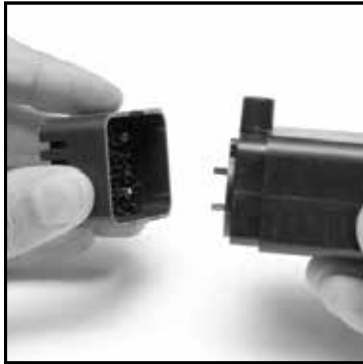

Step 1



Step 2



Step 3



Step 4

IMPORTANT BATTERY SAFETY INSTRUCTIONS:

PROPOSITION 65 WARNING: Battery posts, terminals and related accessories contain lead and lead compounds, chemicals known to the State of California to cause cancer and reproductive harm. Wash hands after handling.

WARNING: When using electric devices, basic safety precautions should always be followed to reduce the risk of fire, electric shock and personal injury, including the following:

WARNING: 1. Do not incinerate the battery even if it is severely damaged or is completely worn out. The battery can explode in a fire. Check with municipal codes in your area for possible special disposal instructions.

2. If liquid leaks from the battery cell, discontinue use immediately and dispose of properly.

3. Use only 4-1.5V AA Cell Batteries.

4. Do not attempt to disassemble, remodel or destroy the batteries, as it may cause battery leakage, fire, or bursting; and could also create sulfuric acid spills from the battery resulting in possible burns to person and damage to the immediate environment.

5. Never dispose of batteries in the garbage. Disposal of batteries in the garbage is unlawful under state and federal environmental laws and regulations. Always take used batteries to your local battery-recycling center.

LIMITED ONE YEAR WARRANTY

This warranty gives you specific legal rights and you may also have other rights which vary from state to state. This product has a one year limited warranty on all materials and workmanship. Bernini® warrants the original purchaser of this product that the product will be free from manufacturing defects in workmanship and material for a period of one (1) year from the date of original purchase. If within one (1) year this product fails due to defect in material or workmanship, Bernini® will repair, replace or supply any defective part at their option. The purchaser must contact Bernini® and provide a description of the defective part; including digital pictures if requested, with this original purchase documentation as validation of warranty coverage. This warranty does not cover or apply to: (a) damage to the product due to misuse, mishandling, and or abuse; (b) products not used in accordance with instructions; (c) product not assembled or installed according to instructions; and (d) normal wear and tear. Call us for assistance at +1 (619) 449-2392 or you can email or mail us at: 9545 Pathway Street, Santee, CA 92071, customercare@berninifountains.com, Our Customer Care Department is available: Monday - Friday 8:30am to 4:00pm PST / 11:30am - 7:00pm EST

Please read first before returning:

Please call us for assistance at 1-619-449-2392 or email us at customercare@berninifountains.com. Our Customer Care Department is available: Monday - Friday 8:30am to 4:00pm PST, 11:30am to 7:00pm EST. If you have any questions regarding assembly, parts or operation, please visit our website at www.berninifountains.com. You will find instructional videos on how to assemble and operate your fountain and keeps you up to date on our newest products. You can also email us with any questions you have. This product comes with a one year limited warranty against materials and workmanship.