

BREATHING AIR CATALOG

High-Pressure Systems for Safety & Sports Applications



WORLDWIDE QUALITY INNOVATION RELIABILITY



Contract#
GS-07F-195GA



GLOBAL PRESENCE WITH LOCAL SUPPORT





MISSION STATEMENT

Our mission at BAUER COMPRESSORS INC. is to provide the highest quality products and solutions for high pressure air and gas. We are committed to using the latest technology, best materials, most qualified human resources, and the most efficient fabrication techniques. As a result, our equipment solutions offer superior performance along with best value, and are delivered on time, defect-free and are supported to achieve their maximum potential throughout their entire lifecycle.

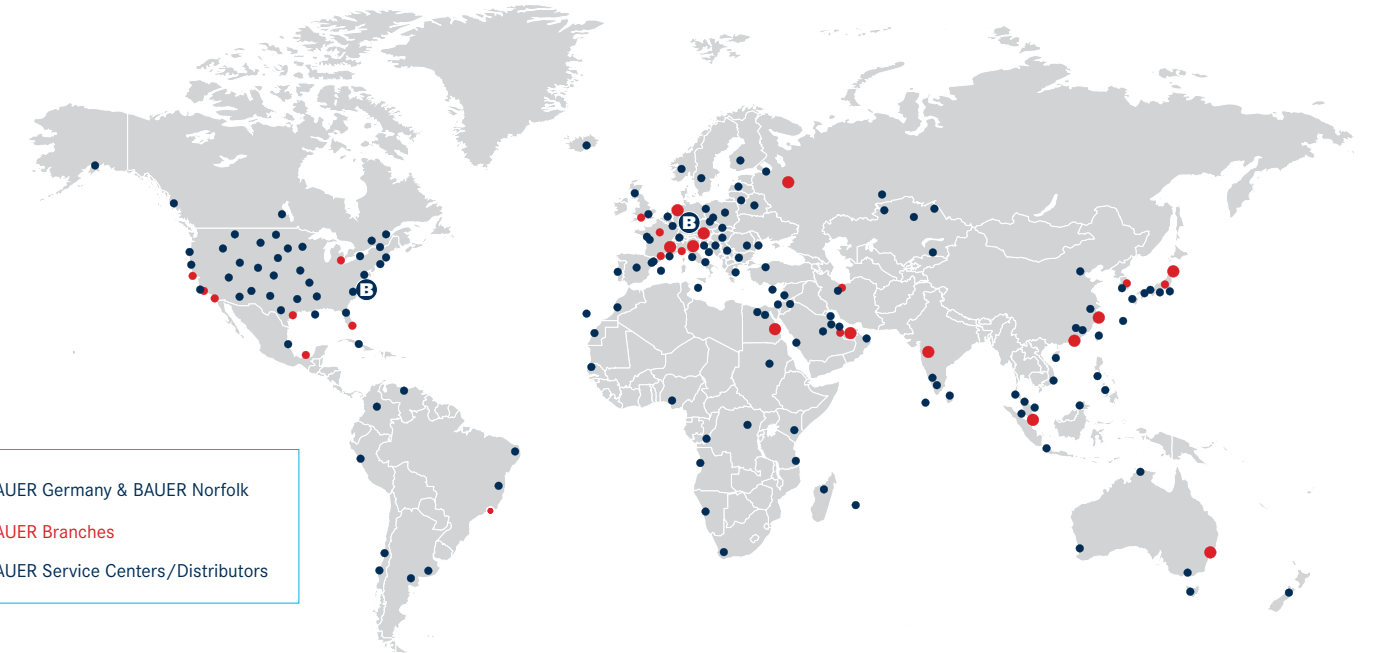
BAUER Corporate Headquarters: North American Manufacturing – Norfolk, Virginia



-  BAUER Germany & BAUER Norfolk
-  BAUER Branches
-  BAUER Service Centers/Distributors

DISTRIBUTOR NETWORK

Supporting you after the sale is a global network of compressor specialists that is unmatched in the industry. Each of our trusted Distributor partners is staffed with BAUER Factory-Trained Technicians and is stocked with a full inventory of products and parts – insuring you receive unsurpassed 24/7 Customer Support, no matter where you are in the world.

Additionally, BAUER has U.S. Sales & Service operations that include branch offices in California, New York, and Florida.



GLOBAL SUPPORT



SINGLE SOURCE RESPONSIBILITY



LOW COST OF OWNERSHIP



LIFECYCLE PERFORMANCE

OUR EXPERIENCE. YOUR BENEFIT.

Our 75 years of experience continues to be a benefit to our worldwide customers by providing them with a diverse selection of field-proven high-pressure breathing air solutions. We are world renowned for reliability and durability, and BAUER as a company is recognized as the world's foremost innovative designer and manufacturer of high pressure compressors of the very highest quality.

BAUER's state-of-the-art 250,000 square-foot facility in Norfolk Virginia means we can stand behind all of the research and development in our breathing-air systems, which are made right here in the U.S.A.



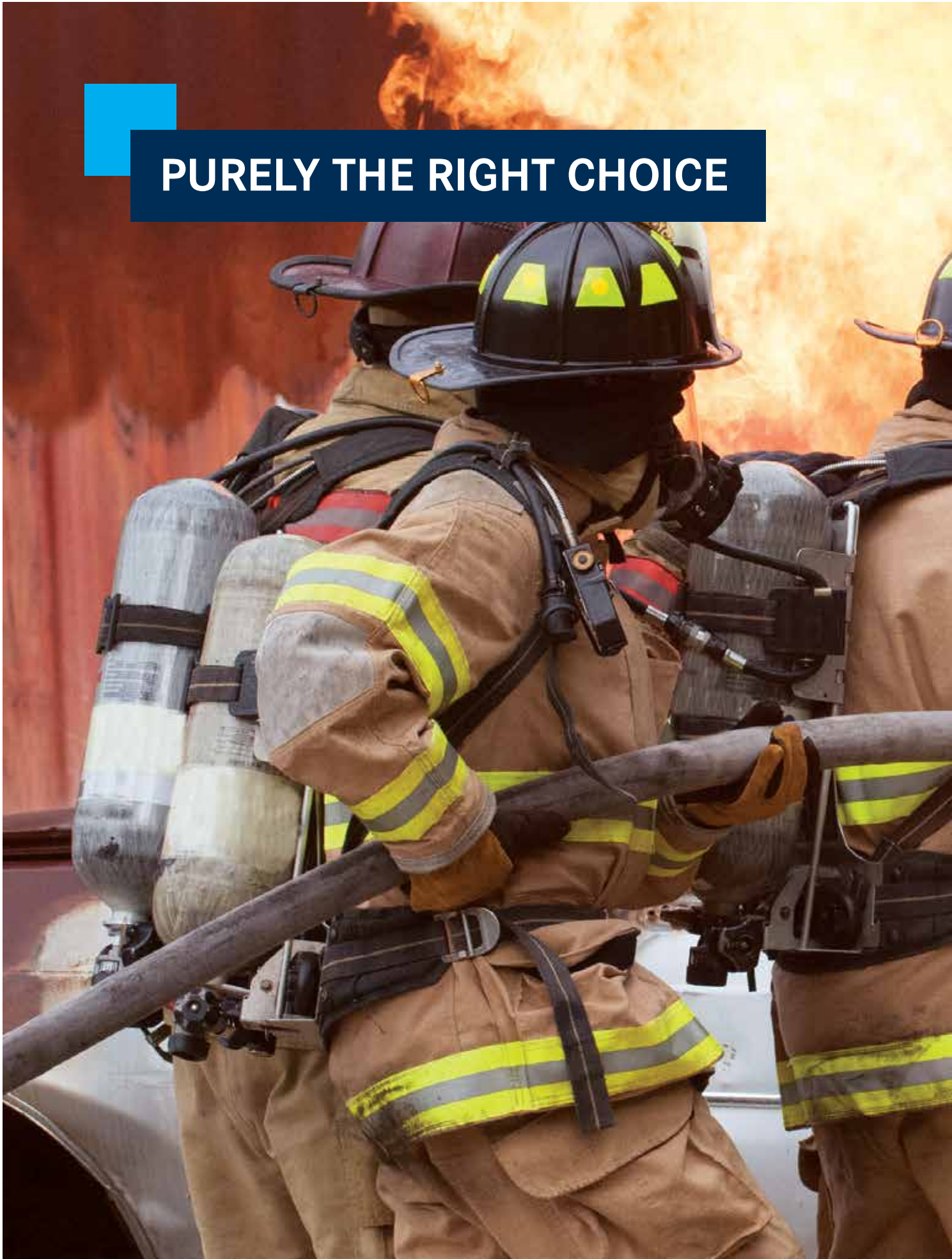

PURELY THE RIGHT CHOICE

CONTENTS

DIVE PRODUCTS

- › Portables 4
- › Dive Mate 6

DIVE AND FIRE PRODUCTS

- › VERTECON® 8
- › VERTICUS® 10

FIRE PRODUCTS

- › Plus Module 12
- › Open Designs 14
- › UNICUS® 4 16
- › UNICUS® 4i 20
- › Engine Driven 22
- › TCOM® Trailer 24
- › TCOM LITE® 26

ACCESSORIES

- › CFS5.5® 28
- › Air Storage 30
- › BAUER RFIDPRO™ 32
- › BAUER CONNECT® for Firefighters 34
- › Quick Reference Guide 36

CUSTOMER SUPPORT

- › Parts, Service, Support & Training 38

D
I
V
E

F
I
R
E

A

C
S

PORTABLES

3-STAGE HIGH PRESSURE BREATHING AIR COMPRESSORS

JUNIOR II and OCEANUS – include an air purification system and fill hose. These safe and reliable 3-stage compressors are designed for serious sport divers. Available in 1-phase 115/230 VAC and 3-phase 230/460 VAC electric motor, gasoline or diesel engine drives.

- › **PRESSURE:**
5000 PSIG (345 BAR)
- › **CHARGING RATE:**
2.9 to 4.9 SCFM
(82 to 139 L/MIN)
- › **POWER:**
2 to 7 HP (1.5 to 5.2 kW)



› **ENGINE DRIVE**

*Diesel Engines are EPA Tier 4 Compliant



› **ELECTRIC DRIVE**



› **YACHTING PACKAGE**

STANDARD SCOPE OF SUPPLY

- › BAUER P0 breathing air purification system
- › Belt guard designed to meet OSHA guidelines
- › Inlet filter
- › Vibration isolators
- › High temperature switch (G drives)
- › Five foot fill hose assembly with SCUBA yoke, bleed valve and pressure gauge

OCEANUS MODELS (ADD TO ABOVE)

- › Sturdy, long lasting low pressure oil pump
- › Large oil sump allows shipboard inclination of 30°(20° G drive)
- › Capable of filling/maintaining up to a two cylinder 5000 PSIG UN storage system
- › Corrosion-resistant coolers and stainless steel frame

YACHTING PACKAGE (ADD TO ABOVE)

- › NEMA - 4 electrical box
- › Motor starter
- › Automatic condensate drain with muffler/separator and condensate reservoir
- › Pressure switch
- › Stainless steel fittings

TECHNICAL DATA

Model	Charging Rate ¹		Number of Stages	Motor		FAD ²	RPM	Purification System
	SCFM	L/MIN		HP	kW			
JUNIOR II 5000 PSIG (345 BAR)								
JRII-E1/115	2.9	82	3	2	1.5	2.5	1500	P0
JRII-E1	3.9	110	3	3	2.2	3.2	2100	P0
JRII-E3	3.9	110	3	3	2.2	3.2	2100	P0
JRII-GK	4.3	122	3	6	4.5	3.6	2300	P0
JRII-D	4.3	122	3	4	3	3.6	2300	P0
JUNIOR II YACHTING PACKAGE								
JRII-E1Y/115	2.9	82	3	2	1.5	2.5	1500	P0
JRII-E1Y	3.9	110	3	3	2.2	3.2	2100	P0
JRII-E3Y	3.9	110	3	3	2.2	3.2	2100	P0
OCEANUS 5000 PSIG (345 BAR)								
OCEANUS-E1	4.9	139	3	5	3.7	4.1	2150	P0
OCEANUS-E3	4.9	139	3	5	3.7	4.1	2150	P0
OCEANUS-GK	4.9	139	3	6	4.5	4.1	2150	P0
OCEANUS YACHTING PACKAGE								
OCEANUS-E1Y	4.9	139	3	5	3.7	4.1	2150	P0
OCEANUS-E3Y	4.9	139	3	5	3.7	4.1	2150	P0

Note: JRII is designed for filling an individual SCUBA or SCBA. It is neither designed nor intended for filling cascade storage systems of any kind. 1) Based on recharging an 80 cubic foot tank from 500 to 3000 psig. 2) Compressor capacity referenced to standard inlet conditions. E1/115= Single phase electric, 115 VAC/60 Hz. E1=Single phase electric, 230 VAC/60 Hz. E3=Three phase electric, 208/230/460 VAC/60 Hz. GK=Gasoline engine drive, KOHLER. D=Diesel engine drive, HATZ. Y=Yachting package. Dimensions and weight are approximate and are subject to change.

AVAILABLE ACCESSORIES (FACTORY INSTALLED)

- › Visual CO/Moisture monitor indicator
- › Final pressure switch for gasoline engine
- › Hourmeter/Tachometer (G drive)
- › B-Timer

SYSTEM FOOTPRINT

JUNIOR II:

DIMENSIONS L x W x H inches (mm)

- › JRII-E1/E3: 27" x 14" x 17" (686mm x 356mm x 432mm)
- › JRII-GK: 31" x 14" x 17" (787mm x 356mm x 432mm)
- › JRII-EY: 32" x 16" x 24" (813mm x 406.4mm x 610mm)
- › JRII-D: 46" x 19" x 21" (1168.4mm x 356mm x 533.4mm)

WEIGHT pounds (kg) › 89 - 165 lb (40 - 75 kg)

OCEANUS:

DIMENSIONS L x W x H inches (mm)

- › OCEANUS-E1/E3: 27" x 17" x 17" (686mm x 432mm x 432mm)
- › OCEANUS-GK: 31" x 14" x 17" (787mm x 356mm x 432mm)
- › OCEANUS-EY: 32" x 20" x 17" (686mm x 432mm x 432mm)

WEIGHT pounds (kg) › 96 - 135 lb (44 - 61 kg)

DIVE MATE

3 AND 4-STAGE HIGH PRESSURE BREATHING AIR COMPRESSORS

Our DIVE MATE takes portable breathing air compressors to a new level! Complete with air purification, DIVE MATE is a safe, reliable 3 or 4-stage breathing air compressor designed to give you lightweight portability. Available in your choice of electric motor, gasoline engine or diesel engine drive.

- › **PRESSURE:**
Up to 6000 PSIG
(414 BAR)
- › **CHARGING RATE:**
8.4 to 9.7 SCFM
(170 to 275 L/MIN)
- › **POWER:**
6.4 to 13.5 HP
(4.7 to 10 kW)



› **DIVE MATE**
(SHOWING OPTIONAL HANDLE KIT AND WHEEL KIT)



STANDARD SCOPE OF SUPPLY

- › Available in two sizes 8 & 10 SCFM
 - Choice of prime mover/drive
 - Electric motor, 1-phase or 3-phase
 - Gasoline engine
 - Diesel engine (DMT 08) (EPA Tier 4 Compliant)
- › Inlet filter
- › Stainless steel intercoolers and aftercooler
- › High temperature switch (except D drive)
- › Vibration isolators
- › P31 Purification
- › Low oil pressure switch (electric and engine drive with electric start)
- › Motor starter with NEMA 4 enclosure (electric drive units)
- › Hourmeter
- › Pressure switch
- › Visual CO/moisture indicator

DIVE MATE ELITE (ADD TO ABOVE)

- › Interstage gauges
- › Automatic condensate drain
- › Electric start (DMT 08-GK/D, DMT 10-GK)

AVAILABLE ACCESSORIES (FACTORY INSTALLED)

- › B-Timer (P31)
- › Purification upgrade P31 to P41 (for 6K DMT10 applications)

TECHNICAL DATA

Model	Charging Rate ¹		Number of Stages	Motor		FAD ²	RPM	Purification System
	SCFM	L/MIN		HP	kW			
5000 PSIG (345 BAR)								
DMT08-E1/E3	8.4	238	3	7.5	5.6	7	1250	P31
DMT08-GK	8.4	238	3	9	6.7	7	1250	P31
DMT08-D	8.4	238	3	6.4	4.7	7	1250	P31
5000 PSIG (345 BAR) - 6000 PSIG (414 BAR)								
DMT10-E1/E3	9.7	275	4	7.5	5.6	8.1	1180	P31
DMT10-GK	9.7	275	4	13.5	10	8.1	1180	P31

1) Based on recharging an 80 cubic foot tank from 500 to 3000 psig.
2) Compressor capacity referenced to standard inlet conditions.
E1= Single phase electric, 230 VAC/60 Hz. E3=Three phase electric, 208/230/460 VAC/60 Hz. Other voltages available on request. GK=Gasoline engine drive, KOHLER DH=Diesel engine drive, HATZ Dimensions and weight are approximate and are subject to change.

AVAILABLE ACCESSORIES (DEALER/CUSTOMER INSTALLED)

- › Lift handles
- › Tubular frame
- › Wheel kit (lift handles or tubular frame required)
- › Riser feet for in-house applications (electric drive only)

SYSTEM FOOTPRINT

- DIMENSIONS L X W X H inches (mm)**
- › 43" x 24" x 27" (1092mm x 609mm x 686mm)*
- WEIGHT pounds (kg)**
- › 300 - 400 lb (136 - 181 kg)
- * Base Model

VERTECON®

3, 4 AND 5-STAGE OPEN HIGH PRESSURE BREATHING AIR COMPRESSORS

BAUER's VERTECON series of high pressure breathing air compressor systems have been an industry leader for many years. An economical design featuring the latest BAUER technological enhancements and unsurpassed maintenance accessibility are incorporated within the simplistic platform. The series now features an integral base which eliminates the guess work of product placement, insuring the system has been installed correctly for system ventilation and maintenance accessibility. With the advent of the integral base the compressor package also has the ability of having a sound attenuated enclosure optionally installed at a later date. A refreshed HMI operations panel and electrical control system allow you to tailor the system to your specific requirements. When simple is what you want look to BAUER.

- › **PRESSURE:**
Up to 6000 PSIG (414 BAR)
- › **CHARGING RATE:**
5 to 26.4 SCFM (142 to 748 L/MIN)
- › **POWER:**
5 to 20 HP (3.7 to 15 kW)



STANDARD SCOPE OF SUPPLY

- › BAUER breathing air purification system
- › Open vertical cabinet made of formed sheet and plate goods provide a firm foundation for all pressure bearing components
- › Modern design with unsurpassed maintenance accessibility (no hand tools are required for normal maintenance checks and fluid level confirmation)
- › BAUER PLC based controller with 7" color HMI touchscreen display
- › Belt adjustment tool
- › NEMA 4 rated electrical enclosure with UL® listed control panel
- › All wiring harnesses incorporated within a corrugated loom with number coding for easy system diagnosis
- › Emergency stop push button
- › .049 wall thickness stainless steel tubing throughout; no cheap plastic tubing
- › Rugged powder coat finish
- › Zero loss automatic condensate drain system
- › Interstage pressure gauges (locally mounted)
- › Compressor on/off, final pressure, oil pressure and high temperature shutdown
- › Motor overload indication
- › Final separator counter with shutdown and operator indication
- › Unique integrated positioning base which ensures correct installation everytime

AVAILABLE ACCESSORIES (FACTORY INSTALLED)

- › CO monitoring system
- › B-SECURUS - Electronic moisture monitoring for the purification system
- › B-Kool (floor mount only)
- › H₂S monitoring system with audible alarm
- › Insulated sound attenuated cabinet

SYSTEM FOOTPRINT

VEC05 - VEC13:
DIMENSIONS L X W X H inches (mm)
 › 54" x 34" x 56" (1372.6mm x 863.6mm x 1422.4mm)
WEIGHT pounds (kg)
 › 800 - 900 lb (363 - 408.2 kg)

VEC18 - VEC26:
DIMENSIONS L X W X H inches (mm)
 › 54" x 34" x 63" (1372.6mm x 863.6mm x 1600.2mm)
WEIGHT pounds (kg)
 › 1200 - 1300 lb (544.3 - 589.7 kg)

TECHNICAL DATA

Model	Charging Rate ¹		Number of Stages	Motor		FAD ²	RPM	Purification System
	SCFM	L/MIN		HP	kW			
5000 PSIG (345 BAR)								
VEC08-E1/E3	8.4	238	3	7.5	5.6	7	1250	P31
VEC20-E3	21	595	4	15	11	17.5	1300	P5
VEC26-E3	26.4	748	4	20	15	22	1350	P5
6000 PSIG (414 BAR)								
VEC05-E1/E3	5	142	3	5	3.7	4	1050	P2
VEC10-E1/E3	9.7	275	4	7.5	5.6	8.1	1180	P2
VEC13-E1/E3	13	368	4	10	7.5	10.8	1420	P2
VEC18-E3	18	510	4	15	11	15	1325	P5
VEC25-E3	25.2	714	5	20	15	21	1300	P5

1) Based on recharging an 80 cubic foot tank from 500 to 3000 psig.
 2) Compressor capacity referenced to standard inlet conditions.
 E1= Single phase electric, 230 VAC/60 Hz. E3=Three phase electric, 208/230/460 VAC/60 Hz. Other voltages available on request. Dimensions and weight are approximate and are subject to change.

VERTICUS®

3, 4 AND 5-STAGE ENCLOSED HIGH PRESSURE BREATHING AIR COMPRESSORS

The days of “Breadbox” designed compressor packages are over! Step up to the BAUER VERTICUS. The updated sound attenuated cabinet is equipped with a unique aesthetically pleasing horizontally hinged, and gas shock supported, operations panel, assuring direct and easy access to the drive belts. Vertically hinged and lift-off side maintenance access doors incorporating fast pin technology make removal of the doors a snap – no hand tools are required! The rear panel incorporates integral handles and tabbed lift off design. The front vertically hinged access door is affixed with a hex keyed latch to eliminate the accidental opening of the door while the system is operating. Sound attenuation has been incorporated on every possible panel to provide a nice and quiet operating level of approximately 72 DB (within one-meter). One package size accommodates BAUER high pressure aircooled compressors from 5 to 20 HP motors. Our new, larger, 7” HMI enhances monitoring of system functions.

- › **PRESSURE:**
Up to 6000 PSIG (414 BAR)
- › **CHARGING RATE:**
5 to 42 SCFM (142 to 1190 L/MIN)
- › **POWER:**
5 to 30 HP (3.7 to 22 kW)



› VERTICUS

STANDARD SCOPE OF SUPPLY

- › BAUER breathing air purification system with B-SECURUS
- › BAUER PLC based controller with 7” color HMI touchscreen display
- › NEMA 4 rated electrical enclosure with UL® listed control panel
- › Compressor low oil pressure and high temperature safety shutdowns
- › Emergency stop push button and automatic start/stop control
- › Zero loss automatic condensate drain system with non-corrosive condensate reservoir and integrated float sensor and automatic “Full” indication and compressor shutdown
- › Interstage pressure gauges (locally mounted)
- › Vertically hinged front operations panel and lift-off side maintenance access doors
- › Inlet filter maintenance indicator
- › Unique hinged front operations panel

AVAILABLE ACCESSORIES (FACTORY INSTALLED)

- › CO monitoring system
- › B-Kool (floor mount only)
- › H₂S monitoring system with audible alarm

SYSTEM FOOTPRINT

- VERTICUS:**
VAC5 - VAC26
DIMENSIONS L X W X H inches (mm)
 › 55” x 35” x 70” (1397mm x 737mm x 1778mm)
WEIGHT pounds (kg)
 › 1000 - 1400 lb (453.6 - 635 kg)

TECHNICAL DATA

Model	Charging Rate ¹		Number of Stages	Motor		FAD ²	RPM	Purification System
	SCFM	L/MIN		HP	kW			
5000 PSIG (345 BAR)								
VAC8-E1/E3	8.4	238	3	7.5	5.6	7	1250	P2 B-SECURUS
VAC20-E3	21	595	4	15	11	17.5	1300	P5 B-SECURUS
VAC26-E3	26.4	748	4	20	15	22	1350	P5 B-SECURUS
6000 PSIG (414 BAR)								
VAC5-E1/E3	5	142	3	5	3.7	4	1050	P2 B-SECURUS
VAC10-E1/E3	9.7	275	4	7.5	5.6	8.1	1180	P2 B-SECURUS
VAC13-E1/E3	13	368	4	10	7.5	10.8	1420	P2 B-SECURUS
VAC18-E3	18	510	4	15	11	15	1325	P5 B-SECURUS
VAC25-E3	25.2	714	5	20	15	21	1300	P5 B-SECURUS

1) Based on recharging an 80 cubic foot tank from 500 to 3000 psig.
 2) Compressor capacity referenced to standard inlet conditions.
 3) 30 HP units are in a cabinet other than depicted.
 E1= Single phase electric, 230 VAC/60 Hz. E3=Three phase electric, 208/230/460 VAC/60 Hz. Other voltages available on request. Dimensions and weight are approximate and are subject to change.

PLUS MODULE

3 AND 4-STAGE MULTI-FUNCTIONAL HIGH PRESSURE BREATHING AIR COMPRESSORS VERTICUS® PLUS

The same package amenities found in the VERTICUS high pressure breathing air compressor system, plus a free standing aesthetically pleasing Multi-functional fill station module are combined to create the BAUER VERTICUS PLUS. BAUER'S performance proven CFS5.5-2S NFPA compliant containment fill station; two (2) bank dual function cascade controls; integral air storage rack with two (2) UN/ISO code air storage cylinders; 3-way selector valve to select either air from the compressor or on-board air storage system all come together creating the ultimate fill station. Install the two (2) modules side by side as an all-in-one configuration or apart based on the installation site specifics. Flexibility is the key, look to BAUER to unlock the possibilities.

› CONFIGURATION 1

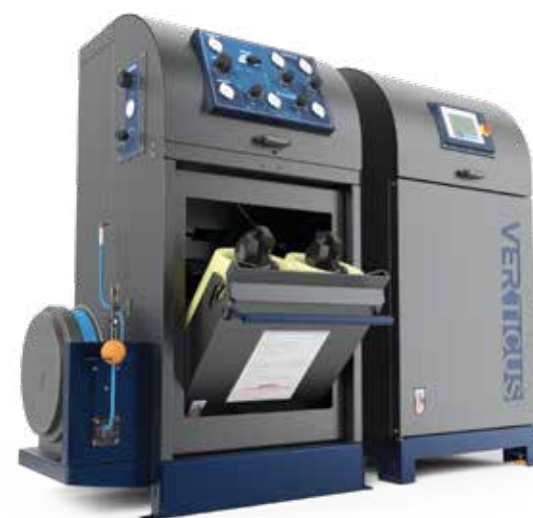
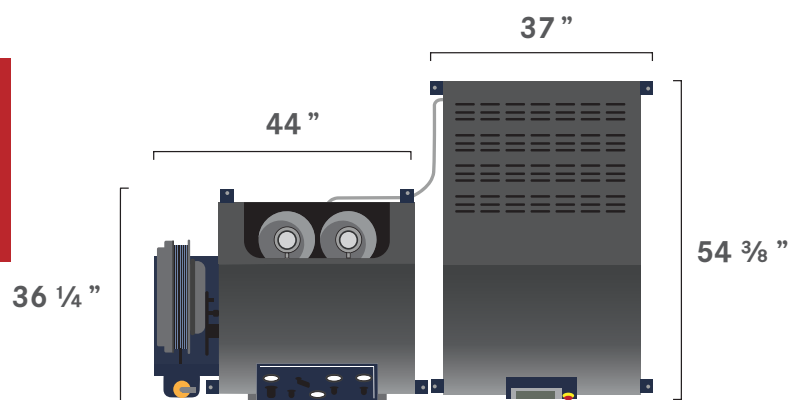

Fill station module showing optional hose reel

› CONFIGURATION 2

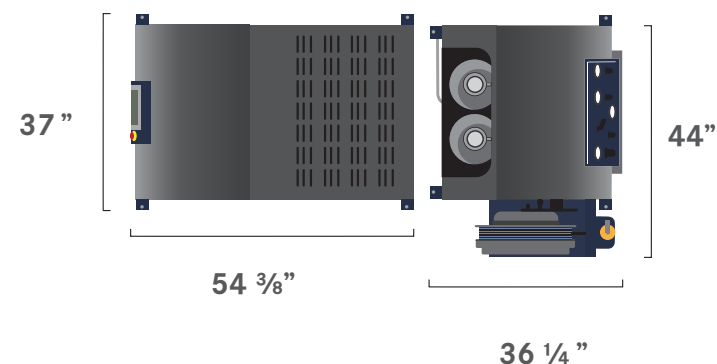

Fill station module showing optional hose reel

NOW AVAILABLE IN TWO NEW EXCITING OFFERINGS!

VERTECON® PLUS

BAUER'S series of high pressure breathing air compressor systems have been an industry leader for many years. An economical design featuring the latest BAUER technological enhancements and unsurpassed maintenance accessibility are incorporated within the simplistic platform. The series now features an integral base which eliminates the guess work of product placement, insuring the system has been installed correctly for system ventilation and maintenance accessibility.

Matched with the VERTECON Compressor is the CFS5.5-2/PLUS: A two position Fully NFPA Compliant (1901 & 1989) SCBA/ SCUBA Fill Station. The CFS5.5-2/PLUS includes an attractive, ergonomically designed, two bank Cascade Fill Control Panel as well as an integral air storage system consisting of two 6000 PSIG UN/ISO air storage cylinders. The VERTECON PLUS System can be further enhanced by the substitution of ASME air storage cylinders in lieu of UN and the addition of the optional Regulated Remote Fill Outlet including a High-pressure Hose Reel and 100 ft. of 6000 PSIG High-Pressure Hose!



Fill station module showing optional hose reel

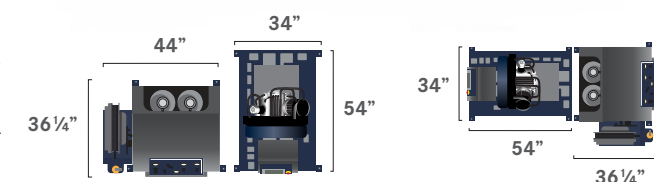

› CONFIGURATION 1

› CONFIGURATION 2

LEGACY PLUS

The new LEGACY Series built in the rugged and proven VERTECON Frame offers "Back To Basics Simplicity" while still incorporating PLC Control! Replacing the HMI / Touchscreen will be a simple, illuminated On/ Off Switch and a set of flashing indicator lamps; the lamps will flash a code representing fault warnings and shutdowns.

Matched with the LEGACY Compressor is the CFS5.5-2/PLUS: A two position Fully NFPA Compliant (1901 & 1989) SCBA/ SCUBA Fill Station. The CFS5.5-2/PLUS includes an attractive, ergonomically designed, two bank Cascade Fill Control Panel as well as an integral air storage system consisting of two 6000 PSIG UN/ISO air storage cylinders. The LEGACY PLUS System can be further enhanced by the substitution of ASME air storage cylinders in lieu of UN/ISO and the addition of the optional Regulated Remote Fill Outlet including a High-pressure Hose Reel and 100 ft. of 6000 PSIG High-Pressure Hose!



Fill station module showing optional hose reel

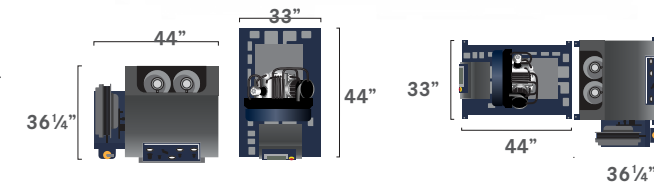

› CONFIGURATION 1

› CONFIGURATION 2

FIRE

FIRE

OPEN DESIGNS

4 AND 5-STAGE HIGH PRESSURE BREATHING AIR COMPRESSORS

Open packages in horizontal or vertical configurations combine compressor and air purification system in a space saving design. These compressors set the standard for larger capacity requirements.

- › **PRESSURE:**
Up to 6000 PSIG (414 BAR)
- › **CHARGING RATE:**
35.9 to 145 SCFM
(1017 to 4106 L/MIN)
- › **POWER:**
30 to 100 HP (22 to 75 kW)



› K42-E3

STANDARD SCOPE OF SUPPLY

- › BAUER breathing air purification system
- › BAUER PLC base controller with four line text display
- › NEMA 4 rated electrical enclosure with UL® listed control panel
- › Compressor low oil pressure and high temperature safety shutdowns
- › Emergency stop push button
- › Automatic condensate drain system with non-corrosive condensate reservoir and integrated float sensor and automatic “Full” indication and compressor shutdown
- › Beltguard designed to meet OSHA guidelines
- › Soft start, isolation contactor, and circuit breaker providing instantaneous short circuit protection
- › Interstage pressure gauges (locally mounted)

AVAILABLE ACCESSORIES (FACTORY INSTALLED)

- › CO monitoring system
- › B-SECURUS - Electronic moisture monitoring for the purification system (K42V-E3 and K42-E3 only)

TECHNICAL DATA

Model	Charging Rate ¹		Number of Stages	Motor		FAD ²	RPM	Purification System
	SCFM	L/MIN		HP	kW			
5000 PSIG (345 BAR)								
K42V-E3 ³	42	1190	4	30	22	35	1300	P10
K42-E3 ³	42	1190	4	30	22	35	1300	P10
K60V-E3	60	1700	4	40	30	50	1350	P12 B-SECURUS
K60-E3	60	1700	4	40	30	50	1350	P12 B-SECURUS
K80-E3	80.4	2277	4	60	45	67	1225	P14 B-SECURUS
K145-E3	145	4106	4	100	75	121	1125	P14 B-SECURUS
6000 PSIG (414 BAR)								
H35V-E3	35.9	1017	4	30	22	29.8	1200	P10 B-SECURUS
H35-E3	35.9	1017	4	30	22	29.8	1200	P10 B-SECURUS
H80-E3	80.4	2277	5	60	45	67	1180	2x P10 B-SECURUS
H96-E3	96	2718	5	75	56	80	1100	2x P10 B-SECURUS

¹ Based on recharging an 80 cubic foot tank from 500 to 3000 psig.
² Compressor capacity referenced to standard inlet conditions.
³ SECURUS electronic moisture monitoring is not standard.
 E3=Three phase electric, 208/230/460 VAC/60 Hz. Other voltages available on request. KV/HV= VERTICAL. K/H= HORIZONTAL. Dimensions and weight are approximate and are subject to change.

FIRE

FIRE

UNICUS® 4

4 AND 5-STAGE ALL-IN-ONE HIGH PRESSURE BREATHING AIR COMPRESSORS

A modern upgrade with the simplicity of analog controls; Aesthetically pleasing yet robust design found only in the UNICUS 4 All-In-One platform. The system is available in either 5000 or 6000 PSIG with discharge capacities ranging from 13 SCFM charge rate to 26 scfm charge rate. Unsurpassed maintenance accessibility abounds as we have provided all access doors with Snap pin technology – pull the pin and lift the door, no hand tools are required. Should you require accessibility to the back of the operations panel, no problem, we have your back, the panel tilts forward. All requisite panels are equipped with sound attenuated material. An integral rack built to accommodate four (4) storage cylinders is standard, along with the piping. Additionally, we provide two (2) ASME coded air storage cylinders as a part of the standard scope of supply. If you want to dress your unit up in concert with the Fire Department theme, ask about our Fire Edition package. When your department needs the best All-In-One compressor system on the market today and backed by our global network of service partners look to BAUER.

- › **PRESSURE:**
Up to 6000 PSIG
(414 BAR)
- › **CHARGING RATE:**
13 to 25 SCFM
(368 to 714 L/MIN)
- › **POWER:**
10 to 20 HP
(7.5 to 15 kW)



UNICUS® 4
FIRE EDITION
OPTIONAL FIRE EDITION PAINT SCHEME
(SHOWN HERE)

STANDARD SCOPE OF SUPPLY

- › BAUER breathing air purification system with B-SECURUS
- › BAUER PLC based controller with 7" color HMI touchscreen display
- › NEMA 4 rated electrical enclosure with UL® listed control panel
- › Compressor low oil pressure and high temperature safety shutdowns
- › Emergency stop push button
- › Hinged cascade fill control panel with Lexan laminate air flow/fill schematic
- › Audible alarm on safety shutdowns
- › Inlet filter maintenance indicator
- › Automatic condensate drain system with non-corrosive condensate reservoir and integrated float sensor and automatic "Full" indication and compressor shutdown
- › Two (2) ASME code stamped air cylinders installed in an integral rack designed to hold four cylinders
- › Sound attenuating enclosure with slam-action latches and lift-off type hinges
- › NFPA 1901 2016 edition compliant 3 position containment fill station accommodates SCBA or SCUBA cylinders up to 31" overall length

AVAILABLE ACCESSORIES (FACTORY INSTALLED)

- › CO monitoring system
- › H₂S monitoring system with audible alarm
- › 100 ft high pressure cabinet enclosed hose reel
- › Additional air storage cylinders
- › Panel mounted remote fill hose connection
- › Dual Fill/3 position
- › Tri Fill/3 position

TECHNICAL DATA

Model	Charging Rate ¹		Number of Stages	Motor		FAD ²	RPM	Purification System
	SCFM	L/MIN		HP	kW			
5000 PSIG (345 BAR)								
UN 4/20-E3	21	595	4	15	11	17.5	1300	P5 B-SECURUS
UN 4/26-E3	26.4	748	4	20	15	22	1350	P5 B-SECURUS
6000 PSIG (414 BAR)								
UN 4/13H-E1/E3	13	368	4	10	7.5	10.8	1420	P2 B-SECURUS
UN 4/18H-E3	18	510	4	15	11	15	1325	P5 B-SECURUS
UN 4/25H-E3	25.2	714	5	20	15	21	1300	P5 B-SECURUS

1) Based on recharging an 80 cubic foot tank from 500 to 3000 psig.
2) Compressor capacity referenced to standard inlet conditions.
E1=Single phase electric, 230 VAC/60 Hz. E3=Three phase electric, 208/230/460 VAC/60 Hz. Other voltages available on request. Dimensions and weight are approximate and are subject to change.

FIRE

OPTIONAL

INNOVATION AT YOUR FINGERTIPS

Lab on Locale 2™ (OPTIONAL)

Analyzes, stores and transmits gas-sample readings via internet to an accredited A2LA lab, to satisfy quarterly air-sample testing & data reporting requirements prescribed by NFPA 1989.

BAUER Gas-Tek™ (OPTIONAL)

State-of-the-Art gas-sensor technology integrated with the HMI display detects trace amounts of harmful gases (CO, O₂, H₂S, CO₂) and automatically shuts off unit, while displaying an alarm.



HMI / Interactive Touch-Screen

Facilitates intuitive control of the entire system, including:

- › Automatic air-storage cascading
- › SCBA-filling
- › Desired regulated fill-pressure

CFS 5.5 BAUER COMPRESSORS

RFID Reader (OPTIONAL)

Data-logging interface, automatically reads & records 6 data-points from the RFID-equipped SCBA cylinders; in accordance with NFPA 1989 data-collection requirements.

WARNING

BEFORE PERFORMING ANY BOTTLE CHARGE, MAKE SURE OF THE FOLLOWING:
FOR HIGH PRESSURE AND PURE BREATHING AIR

- 1. EVERY SCBA BOTTLE IS MARKED ON CONTAINER WITH HIGH PRESSURE RISK
- 2. THE SAFETY RISK OF PRESSURE ACCUMULATION AND EXCESSIVE PRESSURE FOR THE COMBUSTIBLE
- 3. THE BOTTLE MUST BE FREE FROM INTERNAL CORROSION

UNICUS® 4i

4 AND 5-STAGE HIGH PRESSURE BREATHING AIR COMPRESSORS

This game-changing filling station employs our state-of-the-art control system centered around a 15-inch HMI touch screen interface, which allows the operator to manage the entire system from the single-point touch screen. UNICUS® 4i has several innovative optional features including BAUER Gas-Tek™ monitoring system, Lab On Locale 2™ and RFID Reader.

- › **PRESSURE:**
5000 to 6000 PSIG
(345 to 414 BAR)
- › **CHARGING RATE:**
13 to 26.4 SCFM
(368 to 748 L/MIN)
- › **POWER:**
10 to 20 HP
(7.5 to 15 kW)



› UNICUS 4i



› UNICUS 4i
(SHOWING INSIDE FRONT)



› UNICUS 4i
(SHOWING INSIDE BACK)

STANDARD SCOPE OF SUPPLY

- › BAUER breathing air purification system with B-SECURUS
- › **BAUER 15-inch HMI touch-screen** interface
- › Solid state auto cascade system
- › Compressor low oil pressure and high temperature safety shutdowns
- › Emergency stop push button
- › Ergonomic system-operations panel
- › Ergonomically designed stainless steel fill adaptors with integral bleed valve
- › Automatic condensate drain system with non-corrosive condensate reservoir and integrated float sensor and automatic “Full” indication and compressor shutdown
- › Two (2) ASME code stamped air cylinders installed in an integral rack designed to hold four cylinders
- › NFPA 1901 2016 edition compliant 3 position containment fill station accommodates SCBA or SCUBA cylinders up to 31” overall length

AVAILABLE ACCESSORIES (FACTORY INSTALLED)

- › **BAUER Gas-Tek™** gas monitoring system
- › **Lab on Locale 2™** accredited remote air testing system
- › **RFID Reader** which reads and records data from the RFID equipped cylinders
- › Hose reel for 100’ of high pressure breathing air hose
- › Reg/RF
- › Dual Fill/3 position
- › Tri Fill/3 position
- › Additional air storage cylinders

SYSTEM FOOTPRINT

- DIMENSIONS L x W x H inches (mm)**
- › 38” x 101” x 80” (2565mm x 965mm x 2032mm)
- WEIGHT pounds (kg)**
- › 4350 - 4550 lb (1973 - 2064 kg)
- *Weights are based on a unit equipped with 4 ASMEs

TECHNICAL DATA

Model	Charging Rate ¹		Number of Stages	Motor		FAD ²	Purification System
	SCFM	L/MIN		HP	kW		
5000 PSIG (345 BAR)							
UNICUS 4i -26 - E3	26.4	748	4	20	15	22	P5 B-SECURUS
UNICUS 4i -20 - E3	21	595	4	15	11	17.5	P5 B-SECURUS
6000 PSIG (414 BAR)							
UNICUS 4i -13- E1/E3	13	368	4	10	7.5	10.8	P2 B-SECURUS
UNICUS 4i -18- E3	18	510	4	15	11	15	P5 B-SECURUS
UNICUS 4i -25- E3	25.2	714	5	20	15	21	P5 B-SECURUS

1) Based on recharging an 80 cubic foot tank from 500 to 3000 psig.
2) Compressor capacity referenced to standard inlet conditions. Tolerance +/- 5%

F
I
R
E

F
I
R
E

ENGINE DRIVEN

4 AND 5-STAGE HIGH PRESSURE BREATHING AIR COMPRESSORS

The ENGINE DRIVEN compressor for recharging SCBA or SCUBA cylinders combines compressor, purification system and engine drive. The frame's rugged design is specific to the requirements of the engine drive/compressor block assembly.

- › **PRESSURE:**
Up to 6000 PSIG (414 BAR)
- › **CHARGING RATE:**
13 to 60 SCFM
(368 to 1700 L/MIN)
- › **POWER:**
18 to 60 HP (13 to 45 kW)



› H25-D

STANDARD SCOPE OF SUPPLY

- › BAUER breathing air purification system with B-SECURUS
- › BAUER PLC base controller with four line text display
- › NEMA 4 rated electrical enclosure with hourmeter
- › Compressor low oil pressure and high temperature safety shutdowns
- › Emergency stop push button
- › Automatic condensate drain system with non-corrosive condensate reservoir and integrated float sensor and automatic "Full" indication and compressor shutdown
- › Interstage pressure gauges
- › Electric start package including electric clutch and speed control solenoid
- › Closed loop water-cooled diesel

AVAILABLE ACCESSORIES (FACTORY INSTALLED)

- › CO monitoring system

TECHNICAL DATA

Model	Charging Rate ¹		Number of Stages	Motor		FAD ²	RPM	Purification System
	SCFM	L/MIN		HP	kW			
5000 PSIG (345 BAR)								
K20-D	21	595	4	27	20	17.5	1300	P5 B-SECURUS
K26-D	26.4	748	4	27	20	22	1350	P5 B-SECURUS
K42-D	42	1190	4	44	33	35	1300	P10 B-SECURUS
K60-D	60	1700	4	60	45	50	1350	P12 B-SECURUS
6000 PSIG (414 BAR)								
H13-D	13	368	4	18	13	10.8	1420	P2 B-SECURUS
H18-D	18	510	4	27	20	15	1325	P5 B-SECURUS
H25-D	25.2	714	5	27	20	21	1300	P5 B-SECURUS
H35-D	35.9	1017	4	44	33	29.8	1200	P10 B-SECURUS

1) Based on recharging an 80 cubic foot tank from 500 to 3000 psig.
2) Compressor capacity referenced to standard inlet conditions.

SYSTEM FOOTPRINT

- H13-K26:**
DIMENSIONS L X W X H inches (mm)
› 63" x 49" x 46" (1600mm x 1245mm x 1168mm)
WEIGHT pounds (kg)
› 1300 - 3750 lb (590 - 1700 kg)
- H35-K42:**
DIMENSIONS L X W X H inches (mm)
› 52" x 95" x 49" (1320mm x 2413mm x 1245mm)
WEIGHT pounds (kg)
› 1300 - 3750 lb (590 - 1700 kg)
- K60:**
DIMENSIONS L X W X H inches (mm)
› 52" x 112" x 53" (1346mm x 2845mm x 1320mm)
WEIGHT pounds (kg)
› 1300 - 3750 lb (590 - 1700 kg)

FIRE

TCOM[®] TRAILER

4 AND 5-STAGE HIGH PRESSURE MOBILE BREATHING AIR RECHARGING SYSTEMS

When your needs require a rugged trailer built for the fire service, rather than a cheap lightweight imitation, look to BAUER. Our TCOM TRAILER designs are powered by a unique diesel/electric dual drive system. Each system is equipped with a 2 position containment fill station, an enclosed fill control panel, four ASME storage cylinders and integral SCBA storage for up to twelve SCBA cylinders all incorporated onto a heavy duty frame built by BAUER.

- › **PRESSURE:**
6000 PSIG (414 BAR)
- › **CHARGING RATE:**
13 to 25.2 SCFM (368 to 714 L/MIN)
- › **ELECTRIC MOTOR:**
10 to 20 HP (7.5 to 15 kW)
- › **DIESEL ENGINE (EPA Tier 4 Compliant):**
27 to 37 HP (20 to 27 kW)



› TCOM TRAILER

STANDARD SCOPE OF SUPPLY

- › BAUER breathing air purification system with B-SECURUS
- › BAUER PLC based controller with four line text display
- › NEMA 4 rated electrical enclosure with UL[®] listed control panel
- › Automatic condensate drain system with non-corrosive condensate reservoir and integrated float sensor and automatic “Full” indication and compressor shutdown
- › Four (4) 6000 PSIG ASME code stamped air cylinders
- › Integral SCBA storage for up to twelve (12) SCBA cylinders
- › NFPA 1901 2016 edition compliant 2 position containment fill station accommodates SCBA or SCUBA cylinders up to 31” overall length
- › Unique diesel/electrical dual drive system incorporating our exclusive automatic belt tensioning system
- › High gloss powder coat paint for a hard durable finish
- › Hydraulic surge brakes with breakaway actuator
- › Four (4) bank dual function cascade controls with air direction valve
- › Formed structural steel frame designed and built by BAUER
- › Rolled shutter door protection for the operations panel and fill station
- › Refill port
- › CO monitoring system with calibration kit
- › Lunette eye hitch

SYSTEM FOOTPRINT

- DIMENSIONS L x W x H* inches (mm)**
- › 200” x 90” x 105”* (5080mm x 2286mm x 2267mm)
- WEIGHT pounds (kg)**
- › 8400 lb (3810 kg)
- * with optional light mast

AVAILABLE ACCESSORIES (FACTORY INSTALLED)

- › **Option Package A** - Telescoping light mast with four (4) 500 watt fixtures, snorkel tube for compressor air inlet integrated with light mast and 7500 watt auxiliary generator
- › **Option Package B** - Spare tire and wheel chocks with fender well storage
- › **Option Package C** - 100 ft hose reel and interior lights
- › **Option Package D** - 2 5/16” ball hitch
- › **Option Package E** - 100 1/2” L x 5 1/2” H sign boards

TECHNICAL DATA

Model	Charging Rate ¹		Number of Stages	Motor/Engine		FAD ²	RPM	Purification System
	SCFM	L/MIN		HP	kW			
6000 PSIG (414 BAR)								
Tcom-13H	13	368	4	10 - 27	7.5 - 20	10.8	1420	P5 SECURUS
Tcom-25H	25.2	714	5	20 - 37	15 - 27	21	1300	P5 SECURUS

1) Based on recharging an 80 cubic foot tank from 500 to 3000 psig.
2) Compressor capacity referenced to standard inlet conditions.
Image shown with additional accessories. Dimensions and weight are approximate and are subject to change.

FIRE

FIRE

TCOM LITE®

4 AND 5-STAGE HIGH PRESSURE MOBILE BREATHING AIR RECHARGING SYSTEMS

If your needs do not require the amenities of the full-sized TCOM® look to the TCOM LITE®. Designed and manufactured by BAUER for the budget minded customer, the TCOM LITE® utilizes a multi-stage air-cooled compressor coupled to a water-cooled diesel engine (EPA Tier 4 compliant). Our aesthetically pleasing enclosure encompasses the compressor system from inclement weather and road debris and the heavy-duty frame provides a firm foundation for up to four air storage cylinders. The single axle design enhances mobility with most smaller vehicles.

- › **PRESSURE:**
6000 PSIG (414 BAR)
- › **CHARGING RATE:**
13 to 25.2 SCFM (368 to 714 L/MIN)
- › **POWER:**
18 to 27 HP (13.4 to 20 kW)



› TCOM LITE

STANDARD SCOPE OF SUPPLY

- › BAUER breathing air purification system with B-SECURUS
- › BAUER PLC based controller with four line text display
- › NEMA 4 rated electrical enclosure
- › Automatic condensate drain system with non-corrosive condensate reservoir and integrated float sensor and automatic “Full” indication and compressor shutdown
- › Two (2) 6000 PSIG UN code stamped air cylinders
- › Integral SCBA storage for up to twelve (12) SCBA cylinders
- › NFPA 1901 2016 edition compliant 2 position containment fill station accommodates SCBA or SCUBA cylinders up to 31” overall length
- › Unique diesel drive system incorporating our exclusive automatic belt tensioning system
- › High gloss powder coat paint for a hard durable finish
- › Hydraulic surge brakes with breakaway actuator
- › Four (4) bank dual function cascade controls with air direction valve
- › Formed structural steel frame designed and built by BAUER
- › Hypalon® type cover protection for the operations panel and fill station
- › Refill port
- › CO monitoring system with calibration kit
- › 2” ball hitch

SYSTEM FOOTPRINT

- DIMENSIONS L x W x H inches (mm)**
- › 144” x 77” x 72” (3658mm x 1956mm x 1830mm)
- WEIGHT pounds (kg)**
- › 5400 lb (2450 kg)

AVAILABLE ACCESSORIES (FACTORY INSTALLED)

- › **Option Package A** - Spare tire with cover
- › **Option Package B** - 75 ft hose reel and interior lights
- › **Option Package C** - Lunette eye hitch
- › **Option Package D** - Two (2) additional 6000 PSIG UN code stamped air cylinders

TECHNICAL DATA

Model	Charging Rate ¹		Number of Stages	Motor		FAD ²	RPM	Purification System
	SCFM	L/MIN		HP	kW			
6000 PSIG (414 BAR)								
TCL-13H	13	368	4	18	13.4	10.8	1420	P5 B-SECURUS
TCL-25H	25.2	714	5	27	20	21	1300	P5 B-SECURUS

1) Based on recharging an 80 cubic foot tank from 500 to 3000 psig.
2) Compressor capacity referenced to standard inlet conditions.
Image shown with additional accessories. Dimensions and weight are approximate and are subject to change.

FIRE

FIRE

CFS5.5®

CONTAINMENT FILL STATIONS FOR AIR AND OXYGEN

Choose from a complete line of containment fill stations suitable for SCBA or SCUBA cylinders. Whether you need a 3, 2 or single-position fill station, be assured each model was proof tested by an independent lab to safely contain fragments of a ruptured 5500 PSI 110 cu. ft. SCBA cylinder at maximum operating pressure in accordance with the 2016 Edition of NFPA 1901. Ask about our custom options to tailor a model to your specific requirements.

› **FILL POSITIONS:**

- One, two, or three
- Mobile or Stationary

› **CUSTOM DESIGNED SYSTEM:**

- Dual function cascade controls (2 or 3 position)
- Remote fill outlets



› CFS5.5-3S



› CFS5.5-3S

Shown with Cascade controls and regulated remote fill

STANDARD SCOPE OF SUPPLY

- › Complete with cylinder scuff guard, SCBA fill connection, fill hose and bleed valve
- › Fill control panel with adjustable regulator, relief valve, manual control valve and pressure gauge for each fill position (“S” version only)
- › CFS5.5 “M” versions designed for use with remote air distribution panel
- › Mounting base is standard on “S” version and optional on “M” version
- › Convenient door handle actuation
- › Bottom venting
- › Reduced footprint



› CFS5.5-1S



› CFS5.5-2S



› CFS5.5-2S/ CSCD/RF/Reg



› OXY-2S*

SYSTEM FOOTPRINT

CFS5.5-1S & OXY-1S:

DIMENSIONS L X W X H inches (mm)

- › 18” x 21” x 55” (457mm x 533mm x 1397mm)

WEIGHT pounds (kg)

- › 433 lb (196 kg)

CFS5.5-1M & OXY-1M:

DIMENSIONS L X W X H inches (mm)

- › 18” x 21” x 39” (457mm x 533mm x 990mm)

WEIGHT pounds (kg)

- › 360 lb (163 kg)

CFS5.5-2S & OXY-2S:

DIMENSIONS L X W X H inches (mm)

- › 30” x 21” x 53” (762mm x 533mm x 1346mm)

WEIGHT pounds (kg)

- › 670 lb (304 kg)

CFS5.5-2M & OXY-2M:

DIMENSIONS L X W X H inches (mm)

- › 30” x 21” x 39” (762mm x 533mm x 990mm)

WEIGHT pounds (kg)

- › 550 lb (249 kg)

CFS5.5-3S:

DIMENSIONS L X W X H inches (mm)

- › 41” x 21” x 53” (1041mm x 533mm x 1346mm)

WEIGHT pounds (kg)

- › 905 lb (411 kg)

CFS5.5-3M:

DIMENSIONS L X W X H inches (mm)

- › 41” x 21” x 39” (1041mm x 533mm x 990mm)

WEIGHT pounds (kg)

- › 740 lb (336 kg)

*All components in Oxygen stream are Oxygen cleaned in compliance with A.S.T.M. Standard G-93. Dimensions and weight are approximate and are subject to change. Images shown with additional accessories.

AIR STORAGE

UN AND ASME STORAGE SYSTEMS

BAUER high pressure air storage systems meet the code requirements of both the United Nations Model Regulations and the American Society of Mechanical Engineers. Storage cylinders and storage systems are offered for 5000, 6000 and 7000 PSIG applications. Optional mounting racks are available.

- › **PRESSURE:**
5000 PSIG (345 BAR)
6000 PSIG (414 BAR)
7000 PSIG (476 BAR)
- › **CONFIGURATION:**
Vertical
Horizontal
- › **STORAGE:**
Bulk
Bank



› UN STORAGE



› ASME STORAGE

REFERENCE ASY-0759 FOR VERTICAL CONFIGURATIONS
AND ASY-0758 FOR HORIZONTAL CONFIGURATIONS

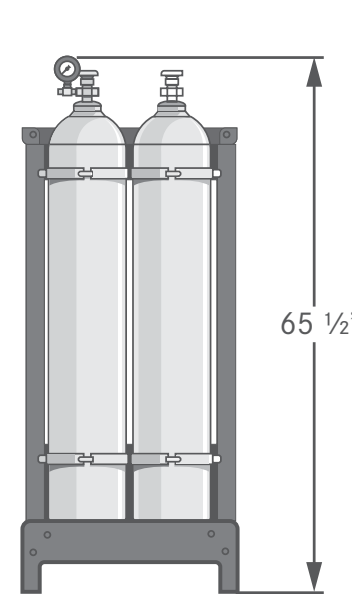

› UN STORAGE

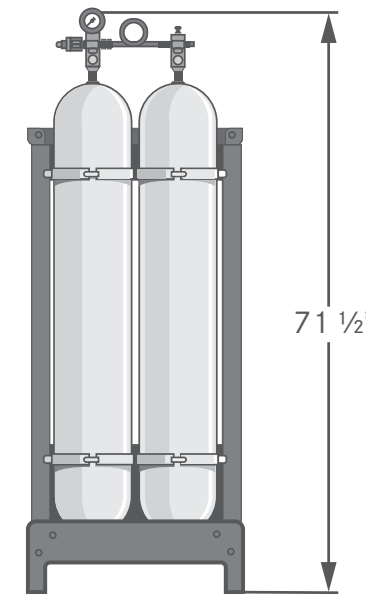

› ASME STORAGE

Model	Weight 2-Cylinder Rack	
	lbs	kg
UN 5000	475	215
UN 6000	525	238
ASME	935	424

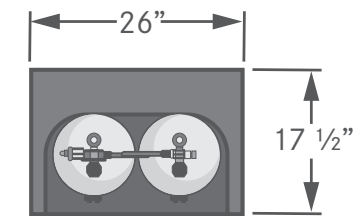

TYPICAL SYSTEMS SHOWN BELOW

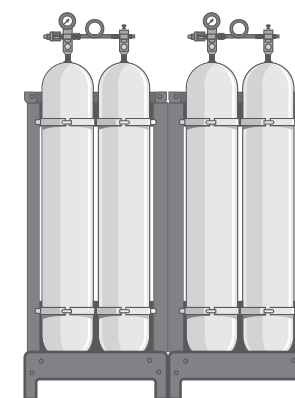

› BULK STORAGE SYSTEM
ASME 4/BANK

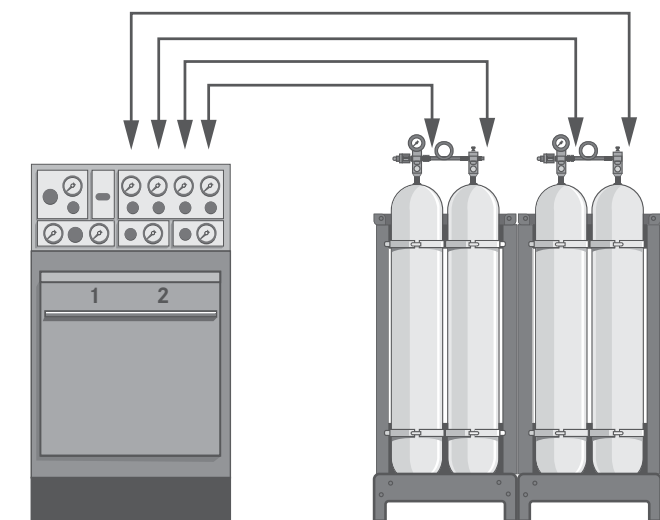

› FOUR BANK CASCADE STORAGE SYSTEM
ASME 4/BANK/1-1-1-1

BAUER RFIDPRO™

a product of
BAUER CONNECT®

RFID CAPABILITY & CONVENIENCE



BAUER RFIDPRO™ SCBA HANDHELD DATA LOGGING DEVICE

For over 75 years, BAUER has been the leader in high-pressure breathing air solutions for firefighting. When there is an opportunity to not only save time but create an even safer environment for your station we take that very seriously. Introducing our new RFIDPRO™ system from BAUER for scanning and recording SCBA data.

The Reader system comes in two options, in a handheld device no larger than a smartphone and an app-based format for mobile download. BAUER RFIDPRO™ Reader is a customer-friendly and convenient option for scanning and logging your SCBA filling events per NFPA 1989. No matter what type of SCBA you own, the BAUER RFIDPRO™ Reader will scan and record any RFID tag. Don't have RFID tags on your SCBAs currently? We can provide any tag for any cylinder to bring this technology easily to you.

The Ultimate Rugged Design:

The device is designed to withstand years of the toughest conditions. The device is virtually waterproof, drop-proof, dust-proof and tumble-proof, with a Gorilla Glass touch panel and imager window that offer maximum scratch-resistance and shatter proofing.

STANDARD FEATURES

- › Generate a report per NFPA 1989
- › Real-time Automated BAUER CONNECT® Cloud Sync¹
- › Offline storage when no connection is available
- › Tracks data per fill event
- › Cylinder inspection checklist with initials
- › Identifies out-of-hydro and/or expired cylinders
- › Warning when filling to incorrect pressure
- › RFID cylinder registration
- › Guest filling feature
- › Intuitive application design
- › Manual barcode scanning for non-RFID equipped cylinders
- › Cloud synchronization
- › Works on all SCBA manufactures RFID technology

¹ Sync when connected to WIFI (BCPROI) or Cellular signal (BCPROII)



To learn more about the BAUER RFIDPRO™ Reader, please contact our Breathing Air Sales team at bauer-connect.com/rfidpro



BAUER CONNECT® REMOTE TELEMETRY AND CONTROL VIA MOBILE APP

In today's age of technology, the saying "time is money" is often heard. Within the firefighting industry, time could mean someone's life. With your job, time is a resource that is often not addressed. What can be done to save you time, give you peace of mind and allow you more time to do what matters most? Introducing BAUER CONNECT® - IoT Solutions for Firefighting - our all-in-one, mobile telemetry solution for optimal ease-of-use and efficiency. For the first time, you can view your SCBA fill data logs, get notifications about your compressor and see and or control your BAUER compressor all under one app. The best part about BAUER CONNECT® is its ability to be tailored to fit your station's needs.

Security Features:

- › Multiple logical & physical security layers
- › Privilege and separation rights
- › AI/ML threat assessment & analysis
- › Transport layer encryption and encryption at rest
- › Extensive logging and monitoring of network, system and application events

BAUER CONNECT® - Connection that matters.

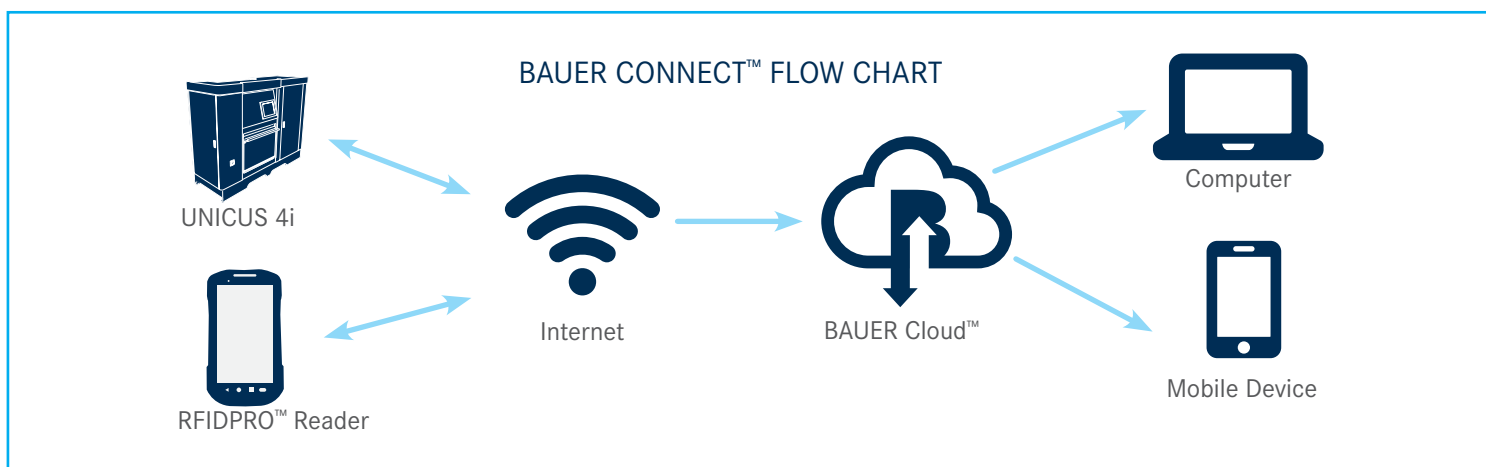

Available on



To sign up and register go to Signup.Bauer-Connect.com

BAUER CONNECT® FUNCTIONS OVERVIEW



BAUER REPORTS™

BAUER Reports™ is a function that generates custom reports tailored to the specific needs of the customer.

SCBA Management Report

- › Generate a report per NFPA 1989 data logging requirements
- › Show when your cylinders were last filled and by who etc.
- › Fill Status Warning: Lists the SCBA the cylinder in inventory that have not been filled within the year
- › Fill activity: Lists the SCBA cylinders serial number, Person filling, RFID serial, cylinder pressure and dates of fill
- › Personnel: List or edit admin, users with privilege to log in to BAUER CONNECT®



Compressor Reports

- › Temperature Trendline Report: Reports ambient temperature as well as temperature of every stage in the compressor



BAUER REMOTE HMI™

- › Live connect and remotely control any BAUER compressor(s) in your station
- › Secure log-ins - Only approved team members can access and control your compressor system
- › Saves time and money with instant control no matter your location



MOBILE DASHBOARDS

- › Quick reference of all of your BAUER compressors at your fingertips
- › Does not require password validation every time app is used
- › Total visual without the Remote HMI control capability (view-only option)
- › Dashboards can be customized to specific customer needs



NOTIFICATIONS

- › Fault on machine
- › Out of Date or Expired SCBA or SCUBA Cylinders
- › Text, email or push notification alarm(s)
- › Allows for instant, proactive steps to be taken if needed



BAUER PREDICTIVE ANALYTICS™

The BAUER Predictive Analytics™ capability provides a new proactive dimension to perpetually maintaining customers' compressor systems at peak conditions with minimum downtime. BAUER's Predictive Analytics algorithm uses artificial intelligence to analyze the collected breathing air system information on the BAUER Cloud™ to predict upcoming maintenance requirements and preventive actions to avoid unplanned shutdowns.



Key Features:



Compressor Features



BAUER Cloud™ RFID Features

QUICK REFERENCE GUIDE

Model	Block	ACD	Gauges	Purification	Visual CO/ Moisture IND	Fill Assembly	Electrical Start	Hourmeter	Working Pressure
DIVE MATE BASE									
DMT08-E1/E3	IK120II	–	–	P31	S	O	–	S	5000 PSIG
DMT08-GK	IK120II	–	–	P31	S	O	–	S	5000 PSIG
DMT08-DH	IK120II	–	–	P31	S	O	–	S	5000 PSIG
DMT10-E1/E3	IK12.14II	–	–	P31	S	O	–	S	6000 PSIG w/P41
DMT10-GK	IK12.14II	–	–	P31	S	O	–	S	6000 PSIG w/P41
DIVE MATE ELITE									
DMT08-E1/E3	IK120II	S	S	P31	S	O	–	S	5000 PSIG
DMT08-GK	IK120II	S	S	P31	S	O	S	S	5000 PSIG
DMT08-DH	IK120II	S	S	P31	S	O	S	S	5000 PSIG
DMT10-E1/E3	IK12.14II	S	S	P31	S	O	–	S	6000 PSIG w/P41
DMT10-GK	IK12.14II	S	S	P31	S	O	S	S	6000 PSIG w/P41

Model	Block	ACD	Gauges	Purification	Securus	CO Mon	H ₂ S Mon	Fill Assembly	Electric Start	Working Pressure
VERTICUS										
VAC5-E1/E3	IK100-420	S	S	P2S	S	O	O	–	–	6000 PSIG
VAC8-E1/E3	IK120II	S	S	P2S	S	O	O	–	–	5000 PSIG
VAC10-E1/E3	IK12.14	S	S	P2S	S	O	O	–	–	6000 PSIG
VAC13-E1/E3	IK12.14	S	S	P2S	S	O	O	–	–	6000 PSIG
VAC18-E3	IK15.11II	S	S	P5S	S	O	O	–	–	6000 PSIG
VAC20-E3	IK180II	S	S	P5S	S	O	O	–	–	5000 PSIG
VAC25-E3	IK18.11II	S	S	P5S	S	O	O	–	–	6000 PSIG
VAC26-E3	IK12.180	S	S	P5S	S	O	O	–	–	5000 PSIG

Model	Block	ACD	Gauges	Purification	Securus	CO Mon	H ₂ S Mon	Fill Assembly	Electric Start	Working Pressure
VERTECON										
VEC05-E1/E3	IK100-420	S	S	P2	O	O	O	O	–	6000 PSIG
VEC08-E1/E3	IK120II	S	S	P31	w/P2	O	O	O	–	5000 PSIG
VEC10-E1/E3	IK12.14II	S	S	P2	O	O	O	O	–	6000 PSIG
VEC13-E1/E3	IK12.14II	S	S	P2	O	O	O	O	–	6000 PSIG
VEC18-E1/E3	IK15.11II	S	S	P5	O	O	O	O	–	6000 PSIG
VEC20-E1/E3	IK150II	S	S	P5	O	O	O	O	–	5000 PSIG
VEC25-E1/E3	IK18.11II	S	S	P5	O	O	O	O	–	6000 PSIG
VEC26-E1/E3	IK180II	S	S	P5	O	O	O	O	–	5000 PSIG
OPEN DESIGNS										
K42-E3/42V-E3	IK22.0	S	S	P10	O	O	O	–	–	5000 PSIG
K60-E3/60V-E3	IK23.0	S	S	P12S	S	O	O	–	–	5000 PSIG
K80-E3	IK25.0	S	S	P14S	S	O	O	–	–	5000 PSIG
K145-E3	IK28.0	S	S	P14S	S	O	O	–	–	5000 PSIG
H35-E3/35V-E3	IK22.42	S	S	P10S	S	O	O	–	–	6000 PSIG
H80-E3	IK25.9	S	S	2x P10S	S	O	O	–	–	6000 PSIG
H96-E3	IK25.18	S	S	2x P10S	S	O	O	–	–	6000 PSIG
ENGINE DRIVEN										
H13-D	IK12.14II	S	S	P2S	S	O	O	–	S	6000 PSIG
H18-D	IK15.11II	S	S	P5S	S	O	O	–	S	6000 PSIG
K20-D	IK150II	S	S	P5S	S	O	O	–	S	5000 PSIG
H25-D	IK18.11II	S	S	P5S	S	O	O	–	S	6000 PSIG
K26-D	IK180II	S	S	P5S	S	O	O	–	S	5000 PSIG
H35-D	IK22.42	S	S	P10S	S	O	O	–	S	6000 PSIG
K42-D	IK22.0	S	S	P10S	S	O	O	–	S	5000 PSIG
K60-D	IK23.0	S	S	P12S	S	O	O	–	S	5000 PSIG

Model	Block	Gauges	Purification	Storage Type	Storage Quantity	Add'l Storage	CO Mon	H ₂ S Mon	Remote Fill	Hose Reel	Working Pressure
VERTICUS PLUS AND UNICUS 4											
VT-P 05-E1/E3	IK100-420	S	P2S	UN	2	–	O	O	O	O	6000 PSIG
VT-P 08-E1/E3	IK120II	S	P2S	UN	2	–	O	O	O	O	5000 PSIG
VT-P 10-E1/E3	IK12.14II	S	P2S	UN	2	–	O	O	O	O	6000 PSIG
VT-P13-E1/E3	IK12.14II	S	P2S	UN	2	–	O	O	O	O	6000 PSIG
UN 4/10-E1/E3	IK12.14II	S	P2S	ASME	2	O	O	O	O	O	6000 PSIG
UN 4/13-E1/E3	IK12.14II	S	P2S	ASME	2	O	O	O	O	O	6000 PSIG
UN 4/18-E1/E3	IK15.11II	S	P5S	ASME	2	O	O	O	O	O	6000 PSIG
UN 4/20-E1/E3	IK180II	S	P5S	ASME	2	O	O	O	O	O	5000 PSIG
UN 4/25-E1/E3	IK18.11II	S	P5S	ASME	2	O	O	O	O	O	6000 PSIG
UN 4/26-E1/E3	IK1180II	S	P5S	ASME	2	O	O	O	O	O	5000 PSIG

S standard O optional – option not available

PARTS



QUALITY AND RELIABILITY

Our factory-original replacement parts assures you that when maintenance or repair is performed, you are restoring the unit to its original specifications and performance.

- 1. Purification
- 2. Gaskets and Seals
- 3. Lubricants
- 4. Fill Hose and Assemblies
- 5. Valves
- 6. Air Intake Filters
- 7. All 10,000+ Parts



7 **PLUS, OVER 10,000 OEM PARTS**

COMPATIBILITY

We configure our designs with interchangeability and our end user in mind. You can count on parts being available for all BAUER models.

PartsSales@BauerComp.com or 1-(844)-500-5822

GLOBAL SERVICE



- B** BAUER Germany & BAUER Norfolk
- BAUER Branches
- BAUER Service Centers/Distributors



SERVICE AND SUPPORT

Our compressors are designed with you in mind. Easy to use manuals guide you through clear, mechanically accessible repairs. Our worldwide distribution network was developed to assist in after-sales support, along with product and maintenance parts assistance.

FROM THE SOURCE

BAUER Compressors Inc., is certified with ISO 9001:2015 quality processes providing you with confidence that cannot be duplicated by sub-standard after-market parts and service.



TRAINING



BAUER Compressors Inc. offers a variety of on site & off site Training Schools. Our on site classes are held at our BAUER Training Facility and are taught by the same people that help manufacture, test and service our products. From electrical systems to hands-on break downs, we cover all areas of compressor operation.

TRAINING TOPICS

Basic mechanical theory, control system theory (electric and pneumatic) along with troubleshooting for all BAUER systems.

Class schedule and course registration at:

www.BauerCustomerTraining.com



BAUER HELPDESK



MECHANICAL & ELECTRICAL

Total customer satisfaction is our top priority. BAUER provides 24-7 phone tech and **troubleshooting** support at our BAUER Helpdesk. Our support continues throughout our warranty period and beyond.

»»» For BAUER Helpdesk please email:
CustomerService@BauerComp.com
or call at:

1-(844)-500-5822



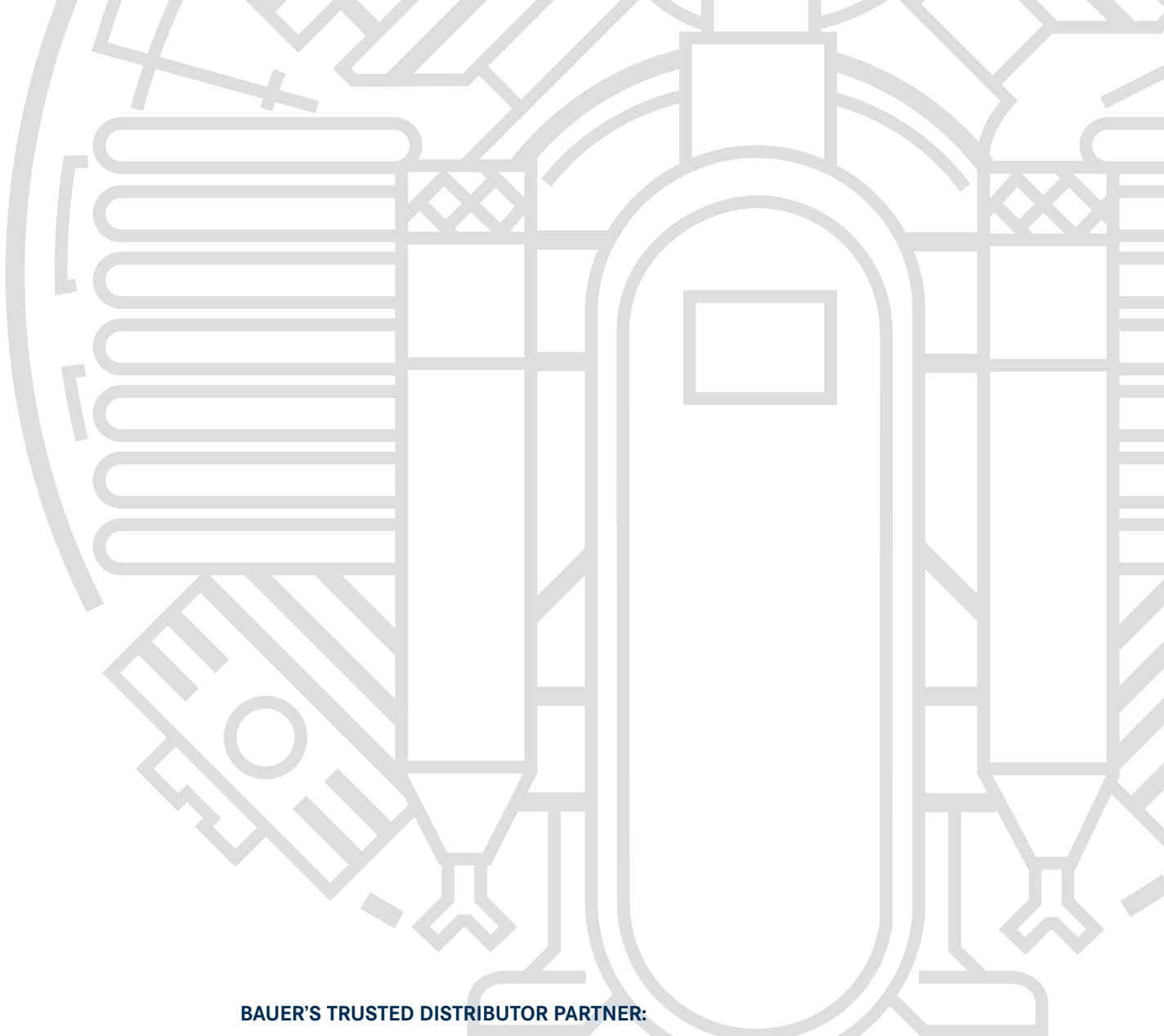

BAUER'S TRUSTED DISTRIBUTOR PARTNER:

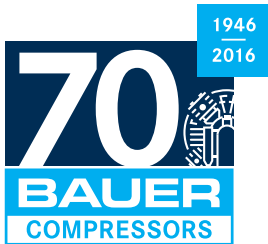

U.S. HEADQUARTERS:
BAUER COMPRESSORS, INC.
1328 Azalea Garden Road
Norfolk, VA 23502
Tel. +1 (757) 855-6006
Fax +1 (757) 857-1041
SLS@BauerComp.com
www.BauerComp.com

U.S. BRANCHES:
BAUER MIAMI
Tel. +1 (954) 746-2504
Fax +1 (954) 746-2510
BFLSales@BauerComp.com

BAUER SAN FRANCISCO
267 East Airway Boulevard
Livermore, CA 94551
Tel. +1 (925) 449-7210
Fax +1 (925) 449-7201
BauerSF@BauerComp.com

BAUER NORTHEAST
2124 State Route 89
Seneca Falls, NY 13148
Tel. +1 (315) 568-5520
Fax +1 (315) 568-5520
Tim.Burgess@BauerComp.com

www.BauerBreathingAir.com

1118.01.20.2000AP
Subject to technical changes