



a q u a t e c

## Permeate Pump Installation Instructions

1. Inspect **Permeate Pump** (Figure 1) and **Optional** items, i.e. 4 fittings, Permeate Mounting Clip Kit, and Retrofit Kit. Remove the plugs from the 4 ports and make sure there is no foreign material in the ports.
2. If you have ordered John Guest stem fittings (optional), firmly attach the 4 fittings to the 4 John Guest ports. Be sure each stem bottoms out in the port.
3. **Mounting of Permeate Pump:** Two methods are commonly used. If you ordered Part Number 25-021 Permeate Mounting Clip Kit, (includes clip and 2 #10 x 3/4" self tapping screws) mount the clip on the system's bracket or other suitable location using the two screws provided. Also available, upon factory request, is a retrofit kit consisting of a membrane housing clip with nut and screw (Figure 3). Drill a #10 hole in the center of the base of the Permeate Pump Mounting Clip and join the two clips (Permeate Pump and membrane housing) at their bases using the screw and nut provided. The Permeate Pump mounts onto the R.O. membrane housing using the clip assembly.
4. The label clearly show the location of each port. Mount the Permeate Pump with Outlets (both brine and permeate) **Positioned Up**. This step is **VERY IMPORTANT** to rid any entrapped air.
5. Shut off feed water and turn off product tank valve. Bleed residual pressure by opening the faucet.
6. Locate the "**BRINE TO DRAIN**" tube. it is extremely important that the flow restrictor is in front of (before) the "brine inlet" to the **Permeate Pump**. The pump **will not operate** if the restrictor is in the "**BRINE OUT**" line leading to the drain.
  - a. If you cut the tube, be sure the cut is **after** the flow restrictor. Insert tube firmly **into "BRINE IN"** fitting on the **Permeate Pump**. Be sure tube bottoms out in the fitting.
  - b. Connect a new length (long enough to reach the air gap drain) of tubing to the "**BRINE OUT**" fitting on the **Permeate Pump**. Be sure tube bottoms out in the fitting. This tube connects directly to the air gap drain.
7. Locate the product water (permeate) tube exiting (after) the membrane leading to the inlet side of the hydraulic shut-off valve. The outlet tube from the hydraulic shut-off valve leads to the TEE on the inlet side of the post-filter which leads to the product water tank and the product delivery faucet as shown in Figure 4.
  - a. Disconnect the tube from the inlet side of the hydraulic shut-off valve and connect the tube to the "**PERMEATE IN**" fitting on the **Permeate Pump**. Be sure the tube bottoms out on the fitting.
  - b. Connect a new tube from the "**PERMEATE OUT**" fitting on the **Permeate Pump** to the inlet side of the hydraulic shut-off valve as shown in Figure 5. Be sure the tube bottoms out on the fitting. If it is desired not to use the hydraulic shut-off valve, connect the permeate pump as shown in Figure 6 (see installation notes).
8. Turn on feed water supply and open product tank valve. The **Permeate Pump** should begin cycling. An audible clicking sound will be heard as the pump operates. Be sure to point this out to your customer so that he understands that this is normal. This will avoid a service call later.

**Important:** If pump is not cycling (clicking), make sure all connections are made correctly and that all entrapped air has been bled from the lines by just cracking open the faucet.

**Note:** The attached specification sheet shows a typical R.O. system diagram for reference. If you want to retrofit another type of R.O. unit (a manifold type) or if your system has another configuration of hydraulic shut-off valve, or if you are using an electric booster pump, consult factory for instruction.

## Technical Specifications (dimensions are in inches)

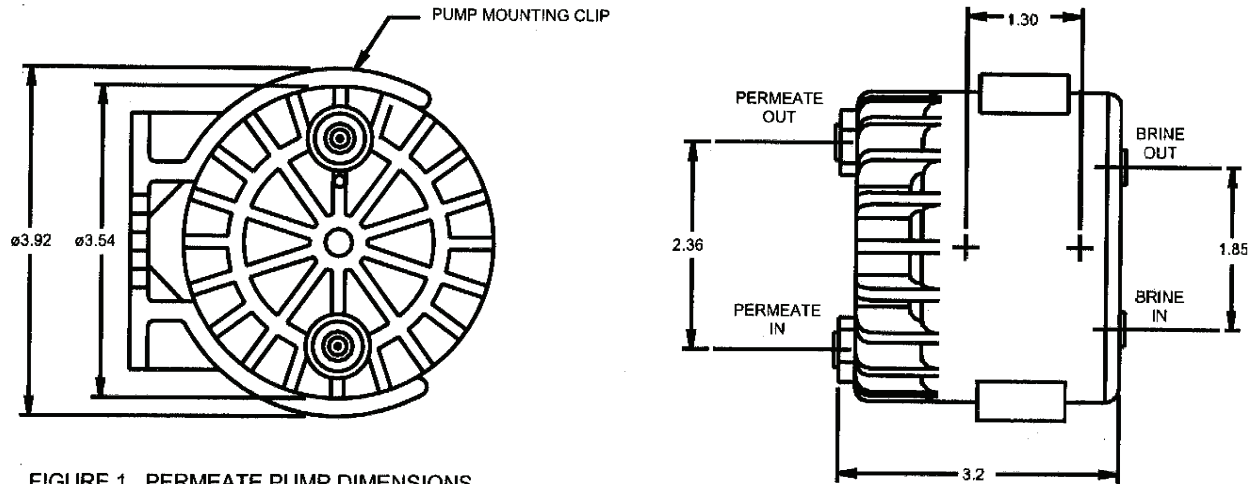

FIGURE 1. PERMEATE PUMP DIMENSIONS

### Installation Notes

As shown in Figure 6, the hydraulic shut off valve may be removed from the system and the Permeate Pump will operate as the shut off valve. This configuration may be used only if a substantial volume of water is drawn from the tank each time. The benefit is that the system will produce more water than with the shut off valve installed. If however, the amount of water withdrawn is small (a cup at a time), it is recommended that the hydraulic shut off valve be retained as shown in Figure 5. This will reduce TDS creep of the RO membrane. The addition of the Permeate Pump decreases the time to fill the tank, but it does not reduce the amount of water produced. For manifold type RO systems, contact the factory for installation recommendations.

### Technical Specifications

- Part number:** ERP 500 – For systems rated up to 50 GPD  
ERP 1000 – For systems rated 50 to 100 GPD
- Pump Type:** Positive displacement, reciprocating, single action diaphragm, hydraulically driven
- Weight:** 1 lb.
- Materials:** Wetted Materials: NSF listed and/or FDA approved
- Fittings:** John Guest® quick disconnect ports - Optional John Guest® elbow fittings (Figure 2)
- Mounting:** Always mount with outlet ports up. Mounting clip (ABS) with (2) #10 S.S. screws available
- Retrofit Mounting:** Order membrane clip if required (Figure 3). Base of Membrane clip attaches to base of Permeate Pump clip with supplied fastener. Permeate Pump can then be mounted to membrane with clip assembly as shown in Figures 5 & 6.
- Hydraulic:** Maximum Pressure - 100 PSI brine and 100 PSI permeate side
- Environmental:** 0 - 100% humidity, 32 - 140 degrees F ambient; water temp, 32 - 140 degrees F

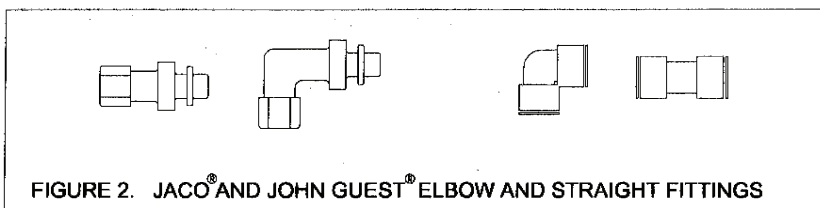

FIGURE 2. JACO® AND JOHN GUEST® ELBOW AND STRAIGHT FITTINGS

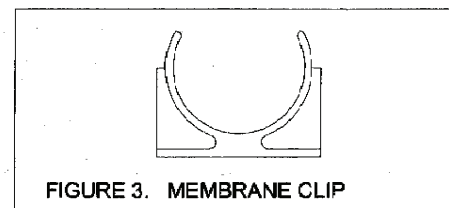

FIGURE 3. MEMBRANE CLIP

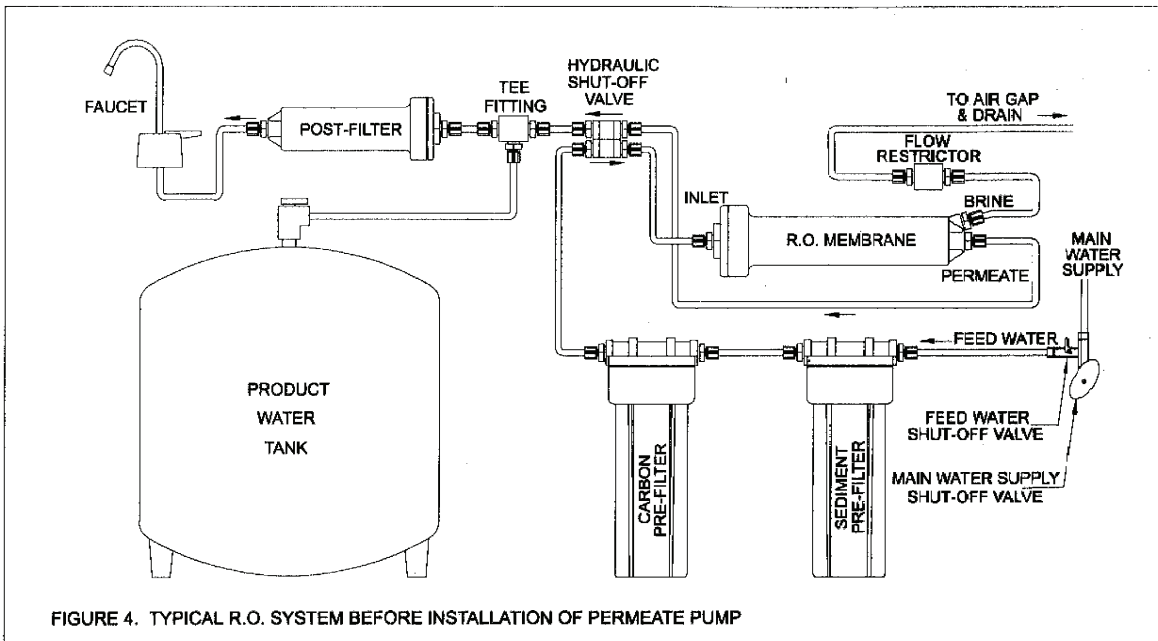

FIGURE 4. TYPICAL R.O. SYSTEM BEFORE INSTALLATION OF PERMEATE PUMP

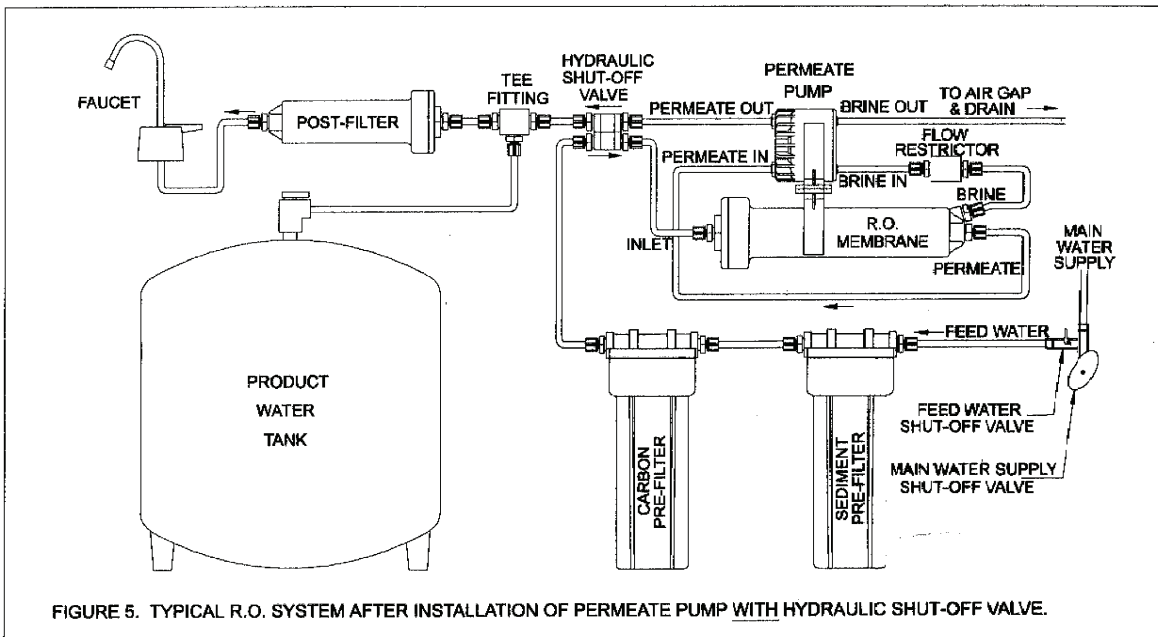

FIGURE 5. TYPICAL R.O. SYSTEM AFTER INSTALLATION OF PERMEATE PUMP WITH HYDRAULIC SHUT-OFF VALVE.

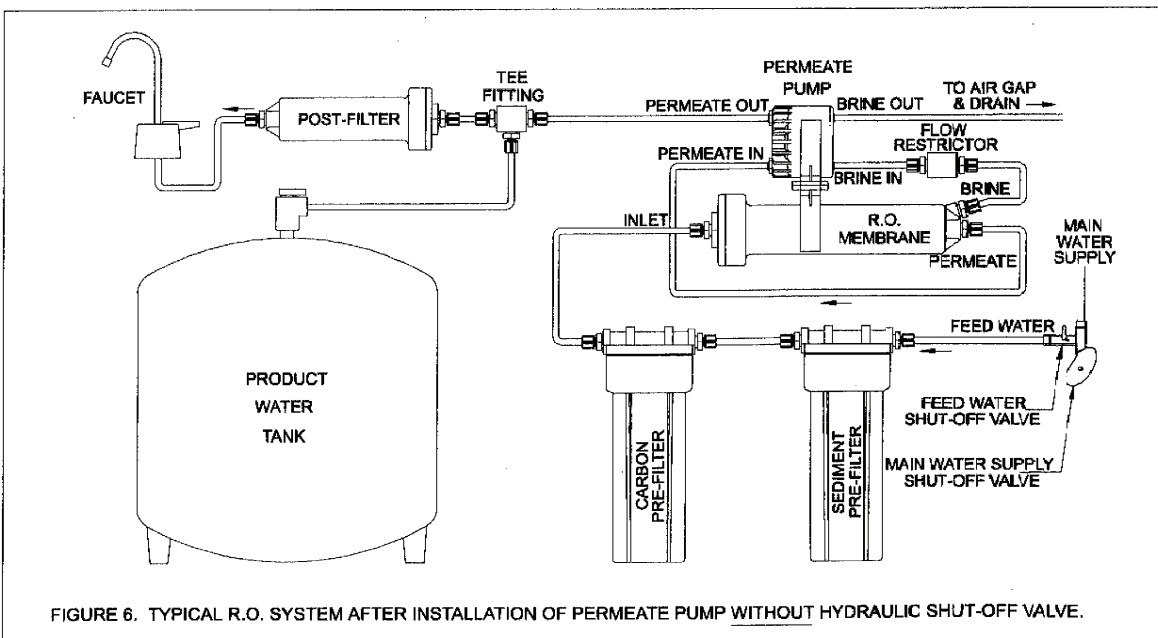

FIGURE 6. TYPICAL R.O. SYSTEM AFTER INSTALLATION OF PERMEATE PUMP WITHOUT HYDRAULIC SHUT-OFF VALVE.

## PERMEATE PUMP INSTALLATION INSTRUCTIONS

This is the side of the pump that the brine ( waste water) connections are made.

After your flow restrictor on the waste line on the way to the drain you install this side of the pump. Run a tube from the flow restriction on your unit to the brine in port on the pump. Then run a tube from the brine out port of the pump to the drain.

Remember the out port must be up when compared to the in port. With the out port in the up position no air can remain trapped in the pump.

The ports are marked check the pump label.



This is the permeate ( pure water ) side of the pump. This side is installed between the membrane and the final filter or the storage tank.

Permeate ( pure water ) from the membrane is connected to the permeate in port. The permeate out port connects to one side of the final filter or to the storage tank. Most systems have a tee on the inlet of the final filter connect to that tee.

When you combine the white clip with the black clip you can mount the pump directly onto the membrane housing.

You may use fittings to make the connection or you can simply push tubing into the ports.

These are push-in fittings and you just firmly push the tube into place.

If you want to remove the tube, First push in on the tube, hold down on the fitting collar with your thumb nail and pull lightly on the tube. If you have properly held the collar down then the tube will slip out pretty easily.

