



Applications:

Suitable for commercial, retail and institutional applications including gymnasiums, factories and warehouses.

Features

- Sealed die-casting profile for indoor and outdoor applications.
- Voltage is 120-277V&347-480V.
- Lumen output from 13000-25000lm with efficacy up to 146lm/W.
- Superior colour rendition index compared to HPS.
- Increase energy savings with bi-level Motion sensor.
- Replacing 250W MH and 400W MH.
- Operating temperature is -40°C to 55°C (-40°F to 131°F).
- UL/cUL and DLC premium qualified.
- Hook mount, pendant mount and surface mount available.



Housing

One piece die cast housing better waterproofing ,suitable for both indoor and outdoor application.

Mounting Bracket

Suitable for hook mount. And the installation steps are simple and safe.

Lens

Polycarbonate optical lens with heat resisting.

PIR Sensor

Optional PIR sensor allows for security and energy saving.



PERFORMANCE DATA

PERFORMANCE DATA			4000K(70CRI)		5000K(70CRI)	
SYSTEM WATTS	PHOTOMETRY	VOLTAGE	LUMENS	LPW	LUMENS	LPW
90W	High Bay	347-480V	13000lm	144lm/W	13000lm	144lm/W
100W	High Bay	120-277VAC	14000lm	140lm/W	14000lm	140lm/W
140W	High Bay	347-480V	20500lm	146lm/W	20500lm	146lm/W
180W	High Bay	120-277VAC	25000lm	139lm/W	25000lm	139lm/W

ELECTRICAL DATA

Number Of Drivers	Driver Current (mA)	Nominal Power (W)	INPUT VOLTAGE (V)	CURRENT (Amps)
2	2400	90	347	0.26
		90	480	0.19
1	2600	100	120	0.83
		100	208	0.48
		100	240	0.42
		100	277	0.36
2	3700	140	347	0.40
		140	480	0.29
1	4540	180	120	1.50
		180	208	0.87
		180	240	0.75
		180	277	0.65

DIMENSION

unit: inch/mm

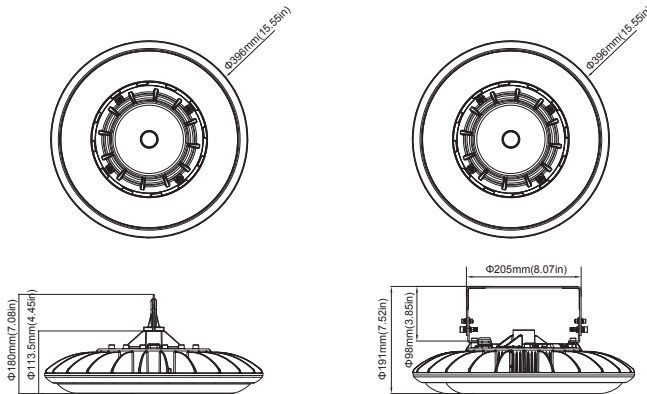

Weight:
100W: 8.3lb
180W: 9.5lb

PHOTOMETRICS

General

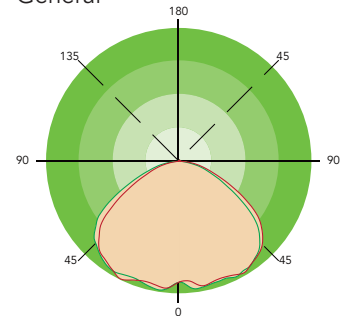

ORDERING GUIDE

Example: MHB02100W27V50KY

Fixture Type	Wattage	Voltage	CCT	Finish	Sensor (Option)
<input type="checkbox"/>	<input type="checkbox"/>	<input type="checkbox"/>	<input type="checkbox"/>	<input type="checkbox"/>	<input type="checkbox"/>
MHB02 High Bay Series	90 90W 100 100W 140 140W 180 180W	27V 120-277V 48V 340-480V	40K 4000K 50K 5000K	D Dark Bronze B Black W White	M4 347-480V motion sensor M With Sensor Blank Without Sensor

DLC Model NO.

SYSTEM WATTS	VOLTAGE	CCT	Dimmable	DLC NO.	DLC Classification
100W	120-277V	4000K	YES	MHB02100W27V40K[B,D,W][Blank,M]	Premium
		5000K	YES	MHB02100W27V50K[B,D,W][Blank,M]	Premium
180W	120-277V	4000K	YES	MHB02180W27V40K[B,D,W][Blank,M]	Premium
		5000K	YES	MHB02180W27V50K[B,D,W][Blank,M]	Premium