

Project: _____
 Product: _____
 Notes: _____



Description

Falkor Lighting's Gas Station Canopy is designed to replace existing under canopy metal halide light fixtures in gas stations. Our Gas station canopy provides longer life, lower energy consumptions and better lighting while eliminating maintenance with our 75,000 hour rated lamp life.

Features:

- Samsung Chips
- Mean Well Driver
- 0-10v Dimmable Product
- Operating Temperature -20°C To 50°C (-4°F To 122°F)
- Suitable For Damp Locations
- L70 Lumen Maintenance Of 100,000 Hours
- 7 Year Limited Warranty / 75,000 Hours



Ordering Guide			
Series	From Factor	Wattage	CCT
C - Canopy	03 - Square Shape	100W - 100 Watts	5000K
		150W - 150 Watts	

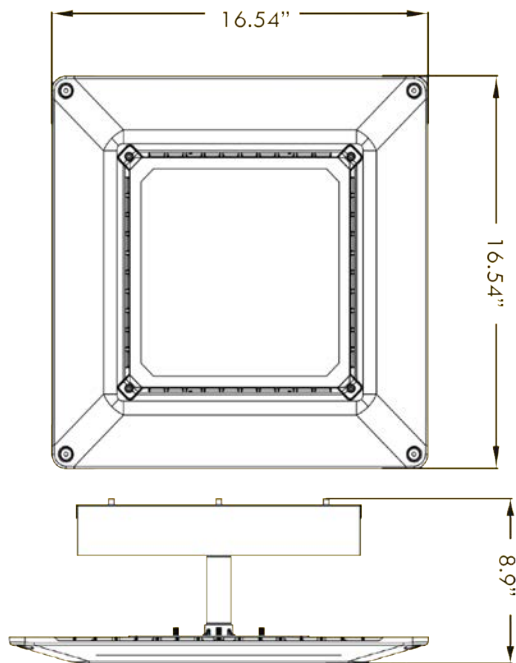

Application

A wide variety of utility applications including gas stations, parking garages, stairwells, pathway and ceiling lighting.

Construction

Manufactured with a housing that is constructed of heavy-duty aluminum, Our gas station canopy comes with a durable matt white polyester powder coating to ensure weather proofing. The optical assembly is sealed with a silicone gasket and are DLC certified with an IP65 rating.

Electrical & Operations

The Gas Station canopy series comes standard with a multi-volt (120-277V) premium driver equipped with 0-10V dimming capability. Nominal temperature operation is -20°C to 50°C. This fixture offers high-efficacy LEDs in either 4000k or 5000K

Warranty

7 year warranty with a 75,000 hour rated L70. See warranty documentation for more detail information.

Carton Dimensions

Model	Carton	Weight	Pieces Per Box
Canopy 100W-150W	18.90" x 18.90" x 6.69"	18.53 lbs	1 Piece Per Box

PERFORMANCE DETAILS

From Factor	Catalog	Rated Wattage	Efficacy	Total Lumens	THD	CRI	PF
3	ETH-C03-100W	100W	152 lm/W	15352	<20%	80	>0.9
3	ETH-C03-150W	150W	130 lm/W	18980	<20%	80	>0.9