

Neck Details:

T: \varnothing 1.725 +/- .015 in (43.815 mm)
 E: \varnothing 1.631 +/- .015 in (41.43 mm)
 I: \varnothing 1.475 +/- .012 in (37.465 mm)
 H: \varnothing .403 +/- .015 in (10.236 mm)
 S: .058 +/- .015 in (1.473 mm)

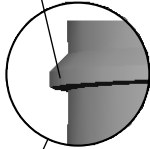

M-style, thread profile



DETAIL A
SCALE 2 : 1



Approximate
Fill Level
225cc (225ml)

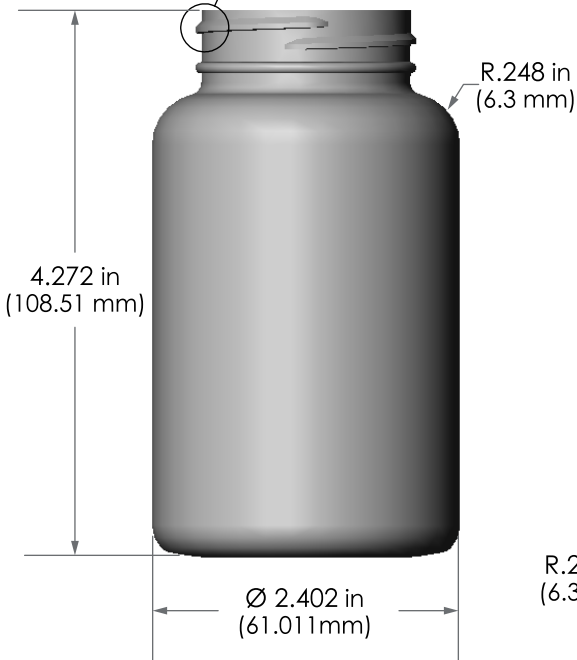

Label Specs
see below

R.248 in
(6.3 mm)

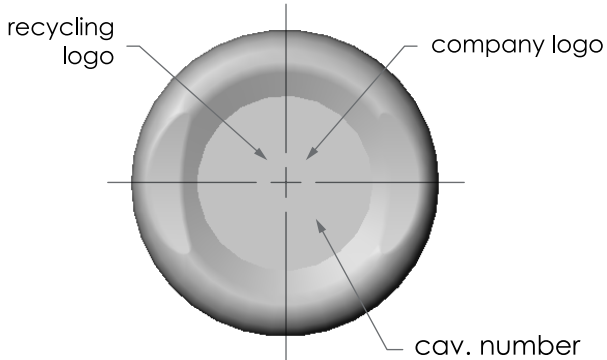

Target Weight: 23 +/- 2g

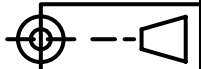

Revised:	
Revised: 11/2/23	Logo, Label specs

225cc HDPE Packer (45-400)

Material: High Density Polyethylene (HDPE)	
Neck: 45-400	Fill Vol: 225cc (225ml)
Scale: 1 : 1.5	Overflow: 260ml +/- 7ml



Aaron Packaging
 4000 150th Avenue Court East
 Sumner, WA 98390
 360-889-0152
 www.aaronpackaging.com

Unless otherwise specified, all dimensions are in inches.

Tolerances :
 angular \pm 3°
 x.xx \pm 0.060"
 x.xxx \pm 0.050"

NOTE: SIZES ARE PRELIMINARY AND SUBJECT TO DEVELOPMENT

Label Specs:

7.421 in (188.493 mm) L x 2.972 in (75.489 mm) H x .08 in (2.03 mm) CR
 Note: Length accounts for .125 in space between label ends.

Drawn by: DC	Dwg. no. : 3713
Created: 01/20/17	