

**Notes:**

M-Style thread, 6TPI, 1 turn  
The height of bottle is adjusted to adapt to caps.

**Neck Details:**

- T:  $\varnothing$  2.049 +/- .015 in (52.045 mm)
- E:  $\varnothing$  1.934 +/- .015 in (49.124 mm)
- I:  $\varnothing$  1.60 +/- .012 in (40.64 mm)
- H:  $\varnothing$  .645 +/- .015 in (16.002 mm)
- S:  $\varnothing$  .046 +/- .015 in (1.168 mm)
- J:  $\varnothing$  .422 +/- .015 in (10.719 mm)

Approximate  
Fill Level  
8 oz (237 ml)

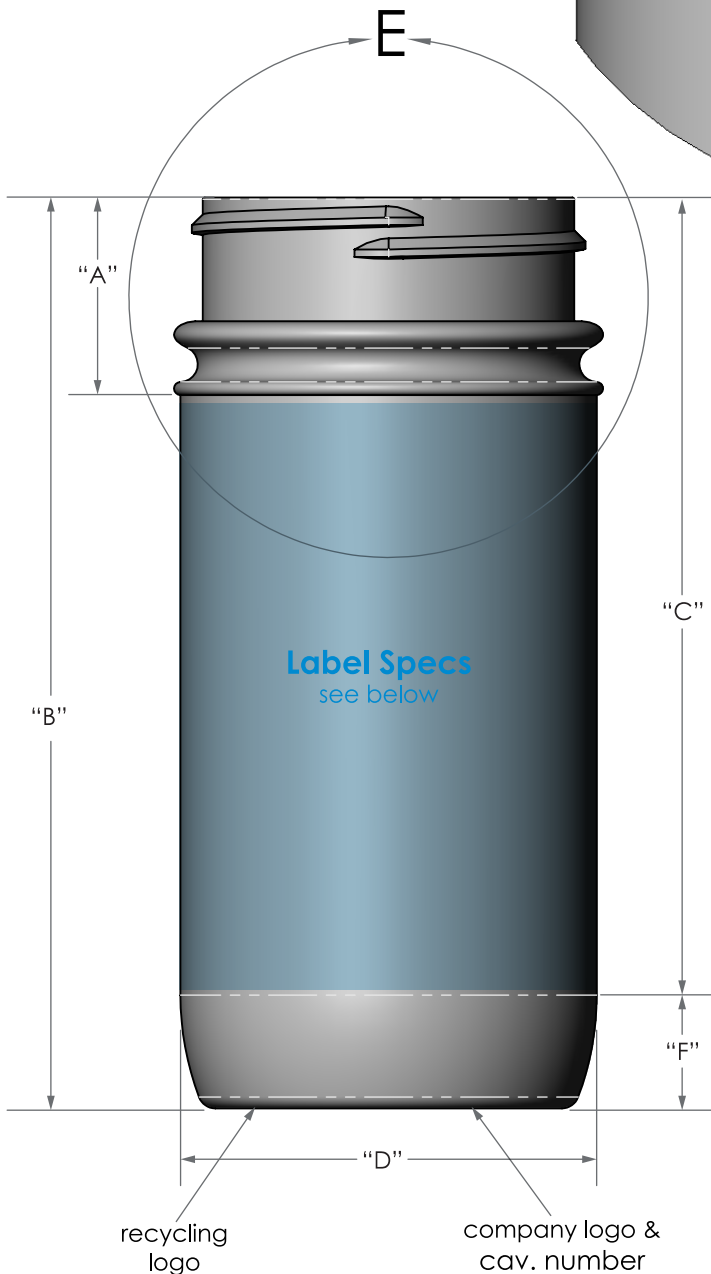
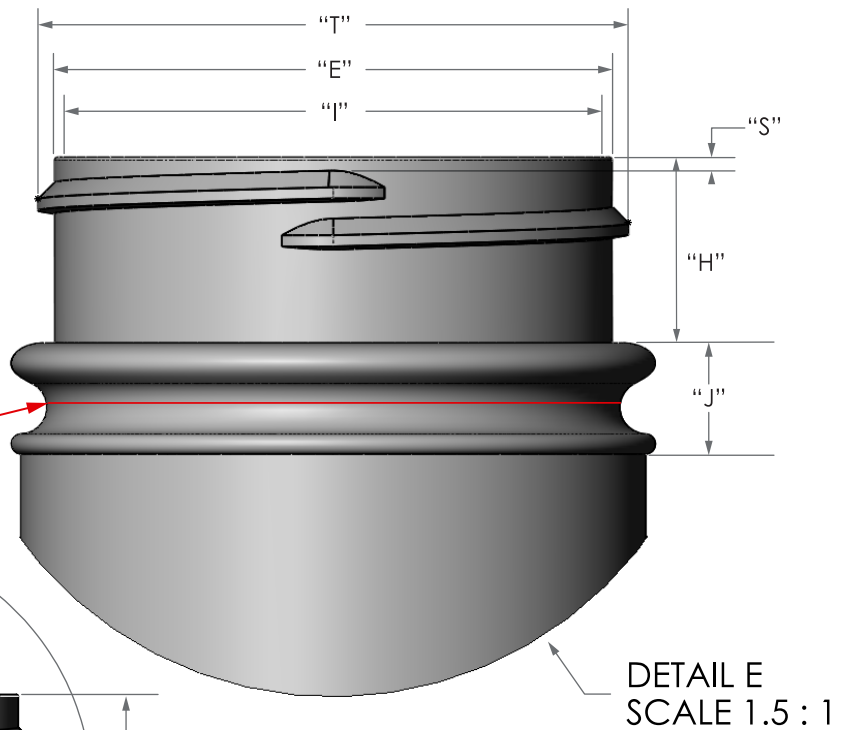

**Body Details:**

- A:  $\varnothing$  1.030 +/- .015 in (26.162 mm)
- B:  $\varnothing$  4.745 +/- .012 in (120.523 mm)
- C:  $\varnothing$  4.070 +/- .012 in (103.378 mm)
- D:  $\varnothing$  2.25 +/- .015 in (57.15 mm)
- F:  $\varnothing$  .65 +/- .015 in (16.51 mm)

Unless otherwise specified, all dimensions are in inches.

Tolerances :  
angular  $\pm 3^\circ$   
x.xx  $\pm 0.060$ "  
x.xxx  $\pm 0.050$ "

NOTE: SIZES ARE PRELIMINARY AND SUBJECT TO DEVELOPMENT

Target Weight: 23 +/- 2 g

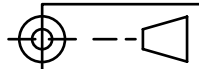

Revised:	
Revised:	
Revised:	
Revised: 11/14/23	logo, label specs

**8oz PP Spice Bottle (53-485)**

Material: Polypropylene (PP)	
Neck: 53-485	Fill Vol: 8 oz (237 ml)
Scale: 1 : 1 (1.5)	Overflow: 248 ml +/- 8 ml



**Aaron Packaging**  
4000 150th Avenue Court East  
Sumner, WA 98390  
360-889-0152  
www.aaronpackaging.com

Drawn by: WC	Dwg. no. : 4012-08
Created: 12/15/22	Mold no. :

**Label Specs:**

6.827 in (173.406 mm) L x 2.925 in (74.295 mm) H x .08 in (2.03 mm) CR  
Note: Length accounts for .125 in space between label ends.