

Neck Details:

T:	4.314 in	(109.58 mm)
E:	4.23 in	(107.45 mm)
I:	3.97 in	(100.84 mm)
H:	.61 in	(15.50 mm)
J:	.862 in	(21.90 mm)
K:	3.5 in	(88.90 mm)
L:	1 in	(25.40 mm)

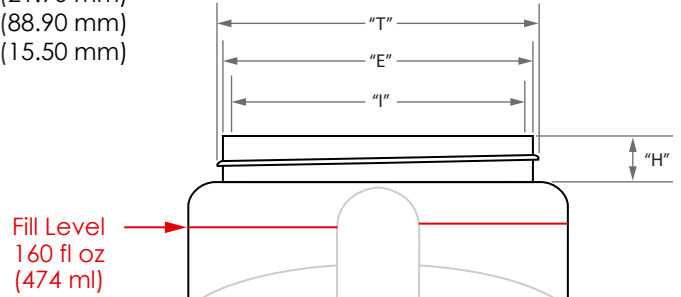

Corner Radius
1 in
(24.5 mm)

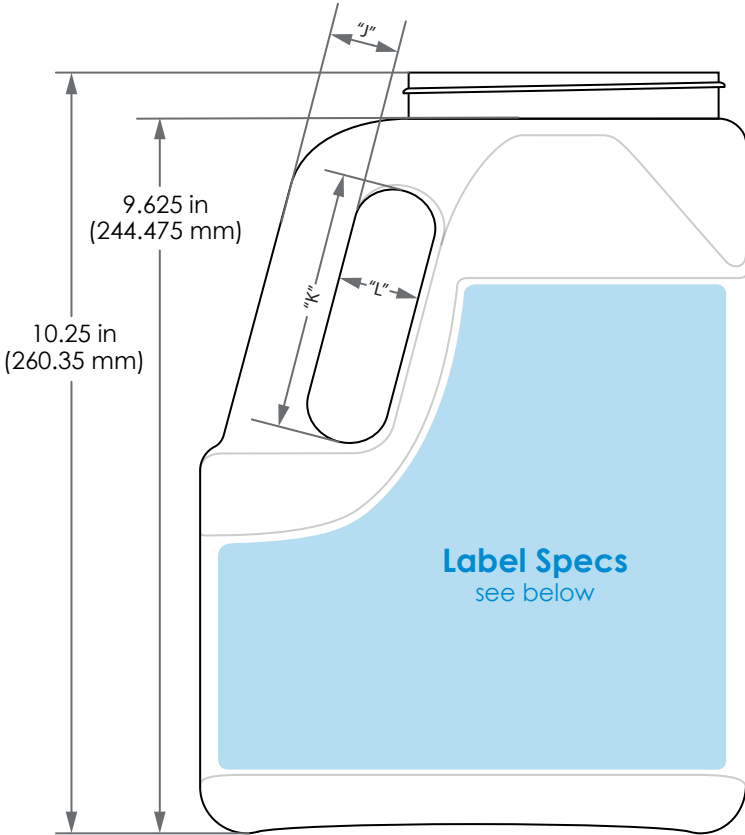
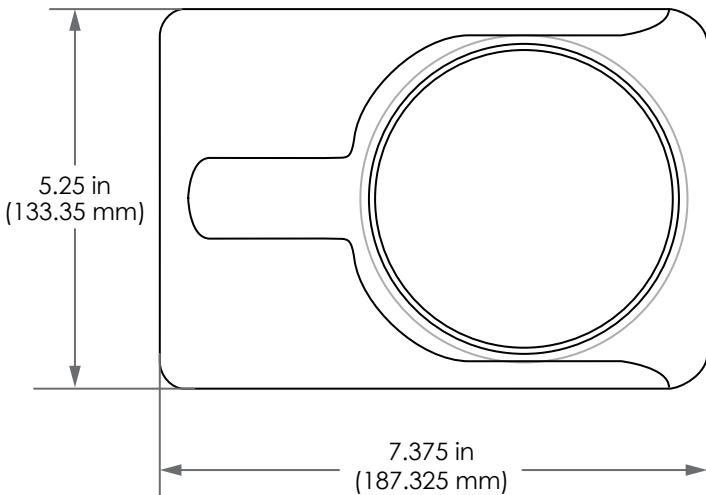

Target Weight: 195g

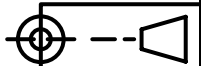

Revised: 9/26/23	label specs, weight
Revised: 9/29/22	specs, logo

160 oz HDPE Square Jug (110-400)	
Material: High Density Polyethylene (HDPE)	
Neck: 110-400	Fill Vol: 160 fl oz (474 ml)
Scale: .375 : 1	Overflow: 526ml +/- 8ml



Aaron Packaging
4000 150th Avenue Court East
Sumner, WA 98390
360-889-0152
www.aaronpackaging.com

Drawn by: DC	Dwg. no. : 17-01
Created: 10/30/17	

NOTE: SIZES ARE PRELIMINARY AND SUBJECT TO DEVELOPMENT

Label Specs:

6.865 in (174.371 mm) L x 6.56 in (166.624 mm) H x .375 in (9.525 mm) CR

DieLine is 100% Actual Size
This is the RIGHT side label panel.
To get the LEFT side label panel, simply flip the Die Line, and copy it.

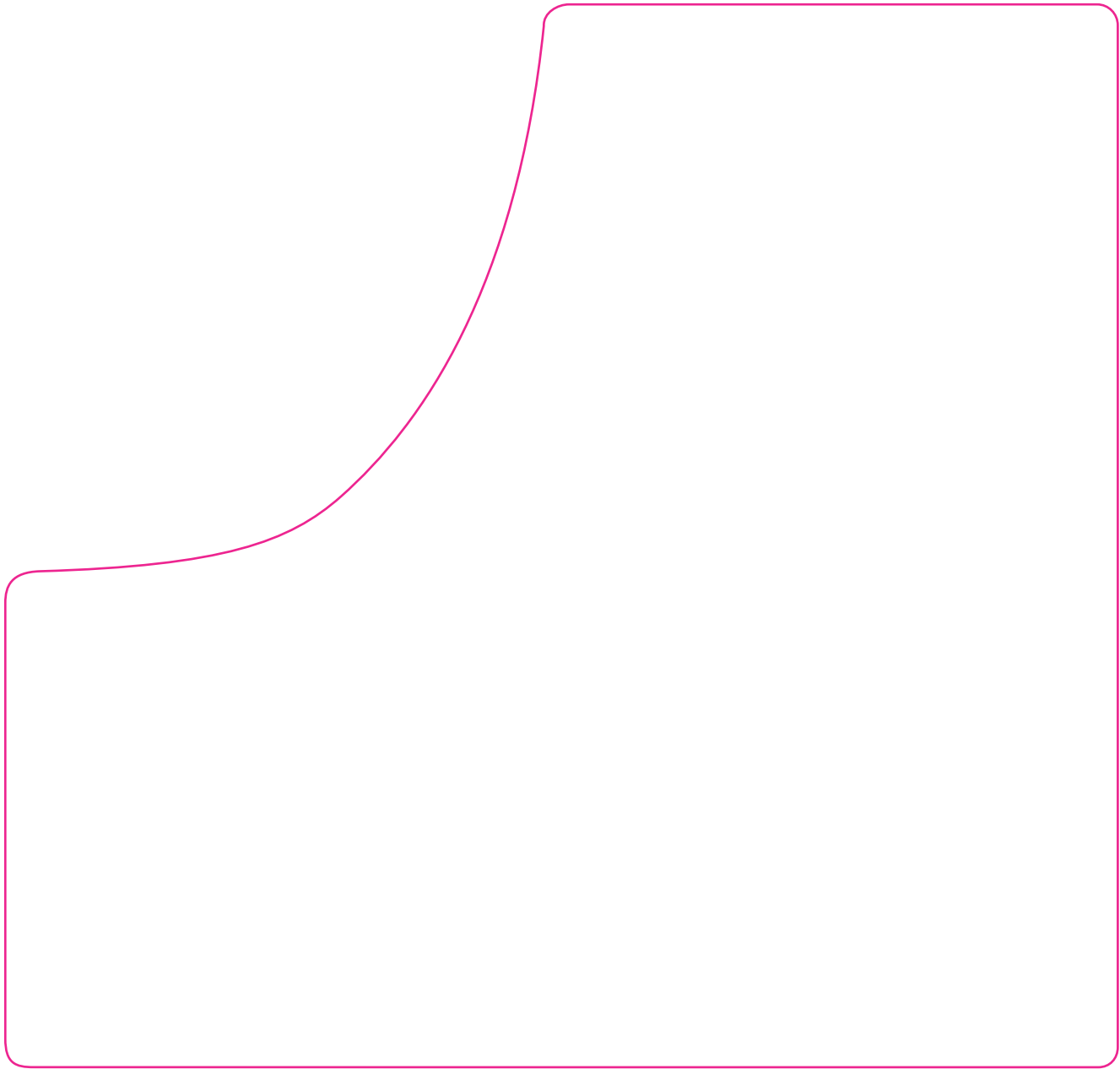

Label Die Line

Project name : 160 oz Square Jug

Scale: 1 : 1

Dwg. no: 17-01-DieLine



Aaron Packaging

4000 150th Avenue Court East

Sumner, WA 98390

360-889-0152

www.aaronpackaging.com

Drawn by: D. Church

Date: 10/30/2017