

Approximate
Fill Level
275cc (275ml)

M-style, 6 TPI, 1 turn

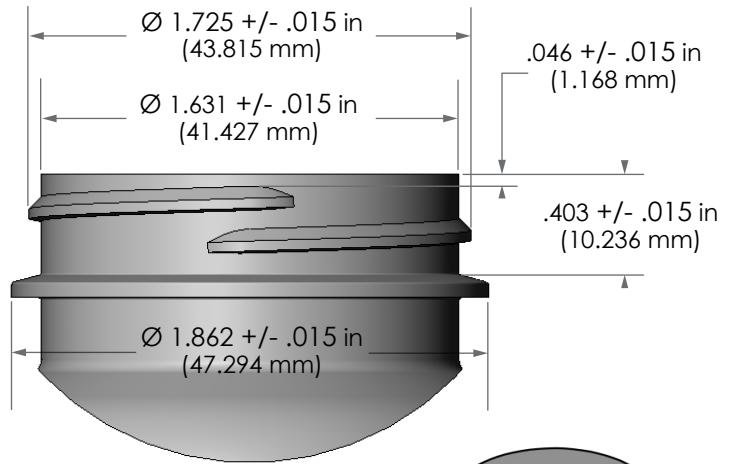

DETAIL A
SCALE 4 : 3

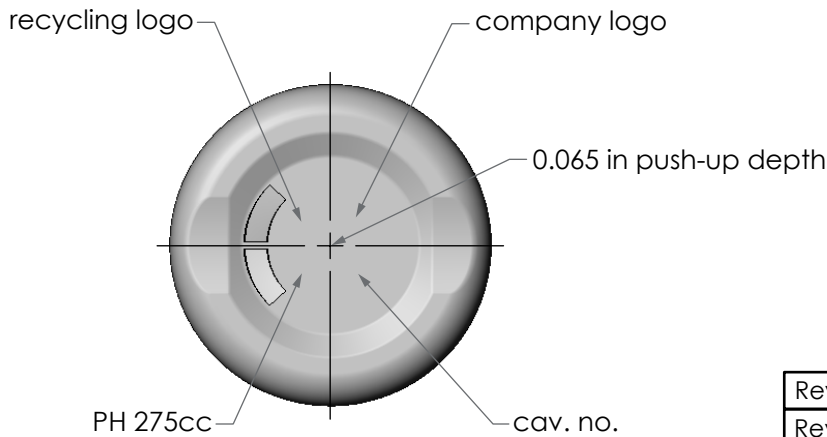

Target Weight: 29 +/- 2 g

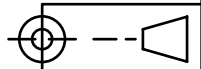

Revised:	
Revised:	
Revised: 11/02/23	gram weight
Revised: 10/09/23	logo, label specs

275cc HDPE Packer (45-400)

Material: High Density Polyethylene (HDPE)	
Neck: 45-400	Fill Vol: 275 cc (275 ml)
Scale: 2 : 3 (4:3)	Overflow: 290.8 cc +/- 9cc



Aaron Packaging
4000 150th Avenue Court East
Sumner, WA 98390
360-889-0152
www.aaronpackaging.com

Drawn by: WC	Dwg. no. : 4034
Created: 09/25/23	Mold no. :

Unless otherwise specified, all dimensions are in inches.

Tolerances :
angular ± 3°
x.xx ± 0.060"
x.xxx ± 0.050"

Note: Sizes are preliminary and subject to development.

Label Specs:

7.751 in (196.875 mm) L x 3.352 in (85.141 mm) H x .08 in (2.03 mm) CR
Note: Length accounts for .125 in space between label ends.