

# DryBuddy**FLEX** INSTRUCTION MANUAL

Important Safety Instructions for Transceiver (Consignes de sécurité importantes)

1. Read these instructions carefully. (Lisez ce attentivement les instructions.)
2. Keep these instructions for later reference. (Conserver ces instructions pour référence ultérieure.)
3. All cautions and warnings should be followed. (Toutes les précautions et les avertissements doivent être suivies.)
4. The rating of the equipment is input & output (La note de l'équipement est entrée & sortie):  
**INPUT for Power Supply: 110-120V ~ 60Hz 300mA 20W or 220-240V ~ 50Hz 150mA 20W**  
**ALIMENTATION électrique: 110-120V ~ 60Hz 300mA 20W ou 220-240V ~ 50Hz 150mA 20W**  
**OUTPUT for Transceiver (Puissance de sortie pour émetteur-récepteur): 12V DC 500mA 6W**

5. The socket-outlet shall be installed near the equipment and shall be easily accessible. (La prise de courant doit être installée près de l'équipement et doit être facilement accessible)
6. The equipment shall be used at maximum 40°C ambient temperature. (L'équipement doit être utilisé à C ambiante. la température maximale de 40)
7. Do not open the equipment to reduce the risk of electrical shock. For safety reasons it is only allowed to be opened by qualified service personnel. (Ne pas ouvrir l'appareil pour réduire le risque de choc électrique. Pour des raisons de sécurité, il est seulement permettre d'être ouvert par un personnel qualifié.)
8. Protect equipment from humidity. (Équipement de protection contre l'humidité.)
9. Equipment has to be protected from objects falling through or liquids dripping through the openings. This could cause a fire or electrical shock. (Équipement doit être protégé contre les chutes d'objets ou de liquides par gouttes à travers les ouvertures. Cela pourrait provoquer un incendie ou un choc réchaud électrique)
10. Disconnect equipment from power supply before cleaning. Do not use any liquid or aerosol cleaner. Use only moistured cloth. (Débranchez les appareils de l'alimentation avant le nettoyage. Ne pas utiliser de nettoyant liquide ou aérosol. Utilisez uniquement un chiffon détrempe.)

11. If the equipment is not used for long time, disconnect the equipment from power supply to avoid being damaged by voltage peaks or lightning strike. (Si l'équipement n'est pas utilisé pendant longtemps, de le débrancher de l'alimentation pour éviter d'être endommagés par des pics de tension ou la foudre.)

12. If one of the following situations arise, equipment has to be checked by qualified service personnel (Si l'une des situations suivantes se posent, de l'équipement doit être vérifié par un personnel qualifié)

- Plug is damaged. (la fiche est endommagé.)
- Liquid has penetrated into the equipment. (Un liquide a pénétré dans l'appareil.)
- Equipment has been exposed to humidity. (L'équipement a été exposé à l'humidité.)
- Equipment has obvious sign of breakage. (Matériel présente des signes évidents de rupture.)
- Equipment does not work well or you cannot get it working according to user's manual. (Équipement ne fonctionne pas bien ou vous ne pouvez pas le faire fonctionner conformément au manuel de l'utilisateur.)

13. The equipment shall not be exposed to dripping or splashing and no object filled with liquids, such as vases, shall be placed on the equipment. (L'équipement ne doit pas être exposé à des gouttes ou des éclaboussures et aucun objet rempli de liquides, tels que des vases, doit être placé sur l'équipement.)

14. For indoor use only. (Pour une utilisation en intérieur.)
15. Polarity of DC output Jack: Center is anode. (Polarité de la prise de DC sortie: Center est anode.)

16. The appliance is designed to supply information technology equipment and similar electrical appliances. (L'appareil est conçu pour fournir l'équipement de technologie de l'information et appareils électriques similaires)

17. This product must not be disposed together with the domestic waste. This product has to be disposed at an authorized place for recycling of electrical and electronic appliances. By collecting and recycling waste, you help save natural resources, and make sure the product is disposed in an environmental friendly and healthy way. (Ce produit ne doit pas être évacué avec les ordures ménagères. Ce produit doit être éliminé dans un lieu autorisé pour le recyclage des appareils électriques et électroniques. Par collecte et de recyclage des déchets, vous aider à économiser les ressources naturelles, et s'assurer que le produit est éliminé d'une manière respectueuse de l'environnement et la santé.)

## DryBuddy**FLEX** Quick-Use Instructions

For detailed instructions and diagrams, please refer to the Instruction Manual.

### Setting Up the DryBuddy**FLEX**.

The DryBuddy**FLEX** system is ready-to-use out of the box.

1. Place the Transceiver on a bed-side table or other convenient location.
2. Plug the power supply into an AC power socket.
3. Plug the power cord into the Power In socket at the rear of the Transceiver.
4. Turn the Transceiver ON by pressing the Power button on the Transceiver OR by pressing the ON button on the Remote. A green light will show on the Transceiver.
5. Press the + or – button on the Transceiver. The alarm will sound, and a red light will flash on the Transceiver. Adjust the volume by pressing the + or – buttons.
6. Change the sound (trumpet fanfare of Berlin siren) by poking a paper clip into the Sound Switch hole on the side of the Transceiver.
7. Stop the Alarm by pressing the OFF button on the Remote OR the ALARM button on the Transceiver.
8. The Transceiver is now set and ready for use.
9. To switch the DryBuddy**FLEX** system OFF, press the OFF button on the Remote or the POWER button on the Transceiver. Now no light will show on the Transceiver.

### Using the DryBuddy**FLEX**.

1. Attach the Sensor to Regular cotton briefs by using its Cap (see diagrams in sections 1 and 2), OR to DryBuddy wetness sensing briefs (see diagrams in sections 1 and 2).
2. With regular cotton briefs, position the sensor to be at the expected point of urination. Please remember that unless the urine reaches the sensor where the two magnets are closest, the sensor cannot sense the wetness and trigger the alarm.
3. The wetness sensing briefs provide a very large area on which the urine can fall and trigger the alarm.
4. Turn the DryBuddy**FLEX** ON by pressing the ON button on the remote OR the POWER button on the Transceiver. A green light will show on the Transceiver.
5. When the alarm sounds, make certain that the patient (or child) is awake and gets out of bed before turning the alarm OFF. Turn the alarm OFF by pressing the OFF button on the Remote or the POWER button on the Transceiver. The green light indicates that the system is again ready for use.
6. If the DryBuddy**FLEX** system is not being used, you can turn the system completely OFF by again pressing the OFF button on the Remote or on the Transceiver so that no lights are on.

### Using the DryBuddy**FLEX** Sensor.

The DryBuddy**FLEX** Sensor is designed to provide 3,000 triggers (switched ON). It is triggered when an electric short occurs across its magnets or snaps. When urine (or salt water for testing) wets the cotton briefs at the point where the two magnets are closest, or when urine on the DryBuddy wetness sensing briefs makes a connection between two adjacent sewed-in wires, a short occurs and the sensor is triggered and transmits its signal.

1. Please note that after the Sensor is triggered, the Sensor will be switched OFF for two (2) minutes. This allows the Sensor to be cleaned and re-set without wasting the Sensor's battery. The sensor will not trigger or work till the two minutes are over.
2. Clean the Sensor and its Cap using warm or cold water and soft soap. Dry the Sensor and cap using soft cloth.
3. For DryBuddy Wetness Sensing Briefs, when using new briefs for the first time, please wash gently by hand using a soft soap or detergent. This will allow the new briefs to become wetness absorbent. Wash the briefs gently using a soft soap or detergent. Dry by air drying or in the air/warm cycle of a dryer. Do not use hot water or hot air. Do not use any treatment.

### Synchronizing the DryBuddy**FLEX** System.

Synchronizing is needed whenever a NEW Transceiver, Sensor or Remote is to be used, or an additional Transceiver is added to the system, or if synchronization has been lost for any reason.

1. Attach ALL system Transceivers to their power supplies and turn all of them ON by pressing the Power buttons.
2. On ALL Transceivers press the + and – buttons at the same time. A beep will sound and a blue light will show on the transceiver(s).
3. While the blue light is showing, short the sensor by placing a clean knife, key or other metallic object across the two sensor magnets. A beep will sound.
4. Then press the OFF button on the Remote. A beep will sound.
5. The blue light will be turned off and the green light will be ON. The system is now synchronized.

## Caution when Using the DryBuddy**FLEX**:

1. The DryBuddy**FLEX** alarm is intended for use as a bed-wetting and enuresis alarm by children of age five and older, or as recommended by a medical authority. It can be used by older patients as a urine sensor and wetness alarm.
2. Do not use as a potty training aid for babies, toddlers and young children.
3. Make certain that no parts of the DryBuddy**FLEX** or sensor are put in the mouth for any reason as this could cause choking or other harm.
4. Observe all sanitary precautions to keep the sensor clean and the alarm parts clean and dry.
5. Do not use the sensor for more than one user without thorough cleaning.
6. Do not strike the magnetic sensor or cap on hard surfaces or make them hot as this can reduce magnetism.
7. The DryBuddy**FLEX** is designed to sense urine or salty water. It is less effective in sensing plain water.

# DryBuddy**FLEX**

## 1 The DryBuddy**FLEX** consists of three important parts:

1. The DryBuddy**FLEX** Sensor,
2. The DryBuddy**FLEX** Remote, and
3. The DryBuddy**FLEX** Transceiver.

### The DryBuddy**FLEX** Sensor

The Sensor is the part that detects urine or other body fluids when used appropriately. To sense when a patient urinates, the user has the flexibility to use the Sensor in one of two ways:

1. The Sensor is attached to standard cotton briefs using the magnets on one side of the Sensor and a magnetic Cap which clamps the sensor to the briefs at the point of urination.

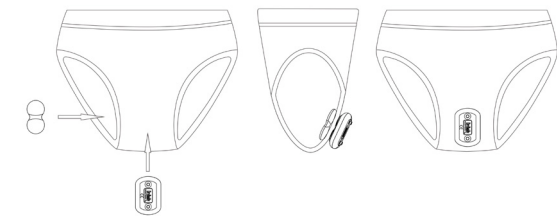

2. The Sensor is attached to special DryBuddy wired briefs using the snaps on one side of the Sensor. These wired briefs are used in place of standard briefs.



Depending on how the Sensor will be used, a Cap and/or special wired Briefs will be needed to allow the Sensor to detect urination

## 2 Using the Sensor with its Cap

The sensor must be on the outside of the briefs at the point of urination, with its circular magnets pointing towards the body. The magnetic cap is placed on the inside of the briefs and directly opposite the magnets, so that the briefs are clamped between the sensor and its cap. See the following illustration for an example.

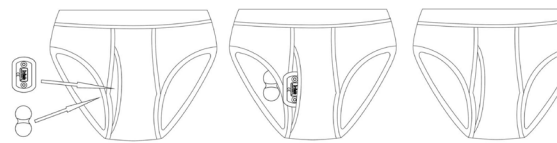

When the patient urinates, the urine is absorbed by (soaks into) the cotton briefs. When the material of the briefs between the two magnets is wet, the sensor will be triggered and a wireless ON signal sent to the Transceiver. Removing the Sensor's magnets from the wet briefs stops further transmission.

### Using the Sensor with DryBuddy Wired Briefs

After the patient wears the DryBuddy wired Briefs, the Sensor's male snaps are inserted into the female snaps of the Briefs till they are firmly attached, and the Velcro on the briefs attached around the Sensor to help keep it firmly in place.

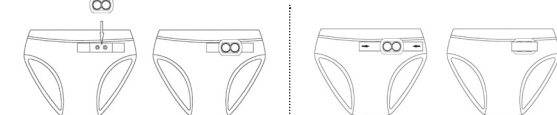

When the patient urinates, the urine is absorbed by (soaks into) the cotton briefs. When the material of the briefs between two adjacent wires is wet, the sensor will be triggered and a wireless ON signal sent to the Transceiver. Removing the Sensor from the wet briefs stops further transmission.

**Note:** Whenever the Sensor is triggered, there will be a three minutes delay before the Sensor can be triggered again. Please remember this during Setup and Use. **Note:** For cleaning the sensor, rinse in cold or warm water and dry with a soft cloth. Do not use hot water or any abrasive substance.

## 3 The DryBuddy**FLEX** Remote

The purpose of the DryBuddy**FLEX** Remote is to make using the DryBuddy**FLEX** system convenient for the caregiver/parent, and thereby help the patient (child).

The DryBuddy**FLEX** Remote is used to remotely turn the Transceiver(s) ON to their READY state. When the Transceiver(s) are OFF, pressing the Remote ON button once, will turn ALL Transceivers ON to their READY state.

When the alarms are sounding, pressing the OFF button on the Remote once will turn ALL alarms OFF. This applies to ALL alarms attached to ALL Transceivers. The Transceivers are now silent but in their READY state.

When the Transceivers are not sounding their alarms, pressing the OFF button on the Remote will turn ALL Transceivers completely OFF. The Transceivers will need to be turned ON to their READY state to be used further.

### General Note

When the Sensor senses wetness, it transmits the ON signal for a fraction of a second. This is sufficient to trigger the wireless DryBuddy**FLEX** Transceiver(s) and generate the alarm, which will stay ON till turned OFF. The Sensor stays in a sleep state for three minutes, after which time it will again transmit the ON signal if it senses wetness. This will be repeated two (2) times, after which the sensor will stop sending any further ON signals. However, to sense the urine and transmit a signal, the Sensor must sense a quick increase in the wetness level for about one second to be certain that the wetness is being caused by urine and not perspiration or some other gradual factor. The Transceiver(s) only need the first ON signal from the Sensor to cause it/them to generate an alarm, and will continue to generate the alarm until the Transceiver(s) is/are turned OFF. Further transmission by the Sensor is not needed, and it is advisable to disconnect the sensor from the wet briefs so that the Sensor's battery power is not wasted with repeated transmissions for the same incident. We recommend that the sensor be promptly removed from the wet briefs. Before washing/cleaning the Sensor, please be certain to turn the entire system OFF by pressing the Remote's OFF switch twice (2 times), or manually pressing the MPS button on ALL of the Transceivers.

## 4 The DryBuddy**FLEX** Transceiver

The DryBuddy**FLEX** Transceiver receives signals from the DryBuddy**FLEX** Sensor, DryBuddy**FLEX** Remote, and other DryBuddy**FLEX** Transceivers that are part of the installed DryBuddy**FLEX** system. Each DryBuddy**FLEX** system uses a specific and original code associated with its Sensor and Remote. Each DryBuddy**FLEX** Transceiver in the system is pre-set to link with (be synchronized with, or work with) this specific Sensor and Remote. If the Sensor or Remote are changed, or if any Transceiver is changed or added to the system, the Transceiver(s) must be re-set to link with the specific Sensor and Remote that are being used.

### DryBuddy**FLEX** Transceiver Setup

SEE INSTALLATION INSTRUCTIONS BEFORE CONNECTING TO THE POWER SUPPLY. (VOIR LA NOTICE D'INSTALLATION AVANT DE RACCORDER AU RÉSEAU.)

Plug the Power Supply into a typical wall electric power outlet. For the U.S., Canada and some other countries this will be 110-120V 60Hz AC. For Europe and some other countries this will be 220-240V 50Hz AC. The Power Supply provided will work at both sets of voltages, but will have different shaped prongs to plug into the local outlet. Then insert the power feed plug at the end of the 2 meters cable into the 12V DC Power In socket at the rear of the Transceiver.

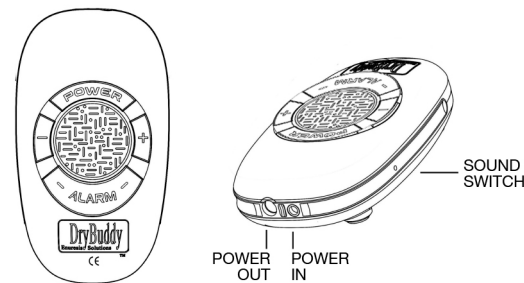

## 5 The DryBuddyFLEX Transceiver

1. To turn the Transceiver ON, manually press the POWER switch on the Transceiver once, or press the ON button of the Remote (the smaller, lower button). A single beep will sound, and the LED at the bottom right of the ALARM button will turn Green. This single Green light indicates that the Transceiver is in its READY state, and can receive the Sensor signal which would turn its alarm(s) on.
2. To turn the Transceiver OFF, manually press the POWER switch once, or press the OFF button of the Remote (the larger, upper button). The Green light on the ALARM button will turn off. The Transceiver is now OFF, and will not receive Sensor signals or activate any alarms. If the POWER switch is pressed when the Transceiver is ON in any way, the Transceiver will be switched completely OFF.
3. To set the Volume of the Transceiver's built-in speaker, the Transceiver must be ON, and the Green light showing. Press the + button (on right side) or the - button (on left side). The speaker/alarm will sound. Each time the + button is pressed, the volume increases by one step till its maximum volume. Each time the - button is pressed, the volume decreases by one step till its minimum volume. Pressing the POWER button on the Transceiver, or the OFF button on the Remote, takes you out of the Volume set program and back into the READY state with the Green light showing.
4. Accessory alarms can be added to each DryBuddyFLEX Transceiver. Each Transceiver has one 12V DC 500ma power outlet on the rear (Power Out). Any accessory which works with this power and has a suitable power plug can be attached. As examples, DryBuddy provides as optional accessories a *Bed Shaker* and an *Audio Alarm*, which use this 12V power outlet and can be set under or next to the patient's pillow. These alarms would supplement the alarm sounding from the Transceiver. When the Transceiver's alarm is turned ON or OFF, these attached alarms will also be turned ON or OFF (See the next drawing).
5. The ALARM Test Switch is used to test the Transceiver's alarm and all attached alarms, by providing power to them and turning them all ON. The ALARM switch will need to be depressed for a few seconds. At this time, the LED under the ALARM switch will blink Red. The accessory audio alarm volume control can be adjusted at this time. When in the ON mode, the built-in speaker's volume cannot be adjusted, and this speaker's volume must be adjusted when out of the ON mode by using the + or - button as described in 3. You must exit the ON mode by pressing the Transceiver ALARM button once or the Remote OFF button once. This will again place the Transceiver in its READY state, and the Green LED will light.

## 6

An optional Audio Alarm or a Bed Shaker can be connected to and used with the Transceiver.

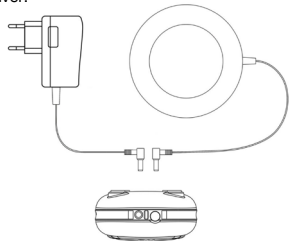

6. Multiple (additional) Transceivers can be used with the DryBuddyFLEX. Additional Transceivers may be placed in the caregiver's (parent's) room, or elsewhere in the house to alert the caregiver. A maximum of five (5) Transceivers can be used in a DryBuddyFLEX system and synchronized to the same system. Sensor and Remote. Each Transceiver can have its volume set as described in 3. To test or set the volume of its accessory alarms, use its ALARM button.
7. Note for the POWER button: Pressing the POWER button ONLY turns the local Transceiver ON or OFF, placing that Transceiver in its READY state or turning it OFF.
8. Note for the ALARM button: Pressing the ALARM button turns ON ALL alarms for ALL Transceivers. Pressing the POWER button on a Transceiver only turns OFF the alarms at that single Transceiver. To manually turn OFF the alarms on ALL Transceivers, each Transceiver's POWER button must be pressed.
9. To turn alarms OFF: When the alarms are ON, to switch ALL alarms OFF on ALL Transceivers, it is necessary to use the OFF button on the Remote. Individual Transceivers can be turned off by manually pressing the POWER button.
10. The Sound Switch on the side of the Transceiver can be activated by pushing a strong thin item into it (a paper clip or thin screw driver). It switches the sound between a Trumpet Fanfare and a Police Siren. When the switch is depressed, the sound will be heard. To change the sound, depress the switch again.

## General Information about DryBuddyFLEX Transceivers & Power Supplies:

FOR INDOOR USE ONLY, DRY LOCATION ONLY  
DRY LOCATION USE ONLY  
OPERATING TEMPERATURE 0°C—40°C  
OPERATING HUMIDITY 15%—95%RH  
STORAGE TEMPERATURE -20°C—70°C  
STORAGE HUMIDITY 15%—95%RH

### Maximum Number of Transceivers in a DryBuddyFLEX system: Five (5)

The wireless transmission range of a Transceiver in a house is up to 95 feet(29 meters). The actual transmission range can vary, be higher or lower, depending upon the materials in the space between adjacent Transceivers. Metal objects in/on the walls, furniture, appliances, etc. in the direct line between Transceivers can reduce the transmission range.

DryBuddyFLEX Transceivers in a system interact with one another interactively, with no constraints or priorities for specific Transceivers. If each Transceiver is within transmission/reception range of any other Transceiver in the system, all Transceivers will function properly. Consequently, for the system to receive a signal from the Sensor or the Remote, having any one Transceiver within receiving range is satisfactory.

## 7 Using The DrybuddyFLEX Transceiver and Initial System Setup:

If you receive the Sensor, Remote and a Transceiver in one pre-packaged box, all of these items will have been synchronized before shipping. Additional or new Transceivers, Sensor or Remote (packed in separate boxes, or obtained as replacements) will need to be synchronized so that all parts of the DryBuddyFLEX system will work properly together. This synchronizing procedure is described in the later section of this instruction manual (Page 11) *Synchronizing The DrybuddyFLEX Sensor, Remote and Transceiver(s)*.

1. Test that the Sensor, Remote and Transceivers are synchronized between themselves by placing the Transceiver(s) in wall outlets in the same room
2. Set the volume of each Transceiver to the desired level. (See page 5, #3)

## 8

3. Turn all of the Transceivers to their READY state by pressing the ON button on the Remote. Every Transceiver's Green LED should light. This indicates that the Remote is synchronized with the Transceivers.
4. Test that the Transceivers can transmit/receive signals from one-another by pressing the ALARM button on one of the Transceivers. If all Transceiver alarms sound and they show a blinking Red light, the Transceivers are synchronized.
5. Turn them OFF by pressing the OFF button on the Remote. The alarms should stop, and every Transceiver will show a Green LED.
6. Take the Sensor, and electrically short the two magnets (or the two male snaps on the other side of the Sensor) by laying a clean conductor such as a key across both magnets or both snaps. This short needs to be in place for about one second or a little more before the Transceiver(s) will respond. If the Transceivers' alarms sound, the Sensor is synchronized with the Transceiver(s). Please note there is a two minute delay before the sensor can be triggered again.
7. Once you have verified that all items are synchronized and work, take the sensor to the location/room where it will be used. Typically, this is where the patient (child) will be sleeping. Place the Power Supply in a wall power outlet and plug its DC power socket into the back of the Transceiver. Place the Transceiver near the patient (for example, on a bed-side table) so that the patient will hear the alarm and wake up. Set the Transceiver into its READY state by pushing the POWER button on the Transceiver or pressing the ON button on the Remote. Verify that the Transceiver will receive the Sensor's transmission by shorting the two magnets or the two snaps on the sensor. The Transceiver's alarm should sound.
8. If you are using a second or additional Transceivers, set one in the room where the caregiver (or parent) will be sleeping, and plug it into a wall outlet. Other Transceivers can be plugged into wall electric outlets where needed. Take the remote to the spot where the caregiver is likely to be when using the Remote. Turn the Transceiver(s) alarms on by pressing the ALARM button on a Transceiver, or shorting the Sensor. All Transceivers should sound. Pressing the OFF button on the Remote should turn all alarms OFF.

The DryBuddyFLEX system has now been set up and is ready for use.

## 9 DryBuddyFLEX Specifications

### Sensor

- Can be used as a "magnetic attachment" sensor when used with its magnetic cap.
  - Can be used as a "wired briefs" sensor when used with the DryBuddy wired briefs.
  - Typical transmission distance within a house is about 90 feet (27 meters). The actual successful transmission distance between the sensor and Transceiver can vary depending on what materials and objects are between the sensor and Transceiver.
  - Sealed unit with non-replaceable battery.
  - Designed and tested to transmit over 3,000 times under typical and proper use.
  - Certifications: FCC RHU-DBFLS02; IC 10836A-DBFLS02
- CE ESTBA150801214R
- RoHS compliant.

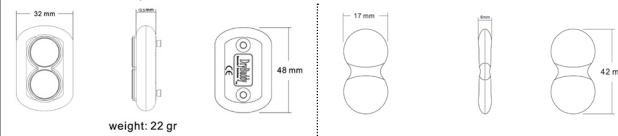

### Remote

- Typical transmission distance within a house is about 90 feet (27 meters). The actual successful transmission distance between the remote and Transceiver can vary depending on what materials and objects are between the Remote and Transceiver.

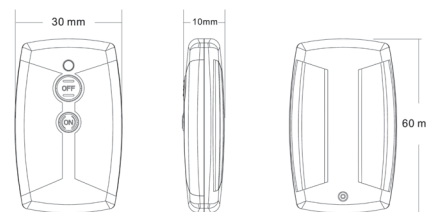

## 10

- Replaceable CR2032 3-volts battery.
  - Certifications: FCC RHU-DBFLM01; IC 10836A-DBFLM01
- CE ESTBA150801212R
- RoHS compliant.
- ### Transceiver
- Typical transmission distance between two Transceivers within a house is about 105 feet (32 meters). The actual successful transmission distance between two Transceivers can vary depending on what materials and objects are between the Transceivers.
  - Uses 12V DC 1 Amp input, provided by a Power Supply.
  - Power Supply uses 110-120V 60Hz AC (UL listed) or 220-240V 50Hz (CE listed).
  - Has one (1) switched power outlet providing 12V DC 500ma. Outlet socket is 1.5mm x 2.5mm barrel sockets, internal positive.
  - Certifications: FCC RHU-DBFLR02; IC 10836A-DBFLR02
- CE ESTBA150801213R
- RoHS compliant.

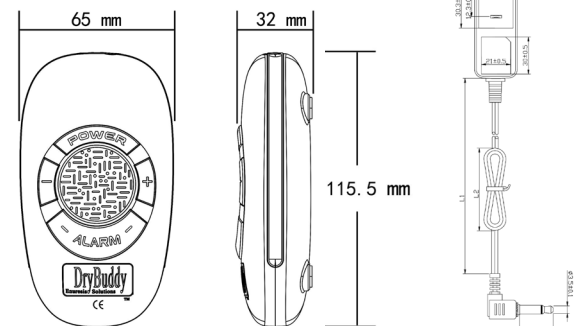

## 11 Synchronizing The DrybuddyFLEX Sensor, Remote and Transceiver(s)

### Setting Addresses for More Than One Transceiver:

Multiple transceivers need to have their addresses set if you are using more than one Transceiver. If you have only one Transceiver, you may skip over this section.

### You will have to set the addresses of the Transceivers if:

1. You have more than one Transceiver, and they have not been synchronized at the factory.
2. You get a new/replacement Transceiver, either as a purchase or an exchange for a defective Transceiver.

### To synchronize the Transceivers:

1. Attach all Transceivers to a power source. Doing this in one room will be more convenient.
2. Press the POWER switch on every Transceiver, so that each Transceiver beeps once and a Green LED lights on every Transceiver(to the right of the ALARM button). Now you know that that all Transceivers are in the READY state.
3. For each Transceiver, press the POWER and ALARM switches simultaneously (at the same time) till you hear one beep and the Green LED starts flashing.
4. The one beep indicates that the first Transceiver is set to address 1. For the second Transceiver press the + button once and you will hear 2 beeps, setting it to address 2. For the third transceiver press the + button twice and you will hear 3 beeps, setting it to address 3. And so on for a maximum of 5 Transceivers in total. The Green LED will be flashing on all Transceivers. It is important that all of the Transceivers have a flashing Green light.
5. After about one minute, the Green LEDs will stop flashing. Note that all Transceivers need to have their addresses set (have flashing Green lights simultaneously) within this one minute. As an option, if you wish to stop the synchronization earlier, press the POWER button once on every Transceiver so that the Green LED no longer flashes.
6. The Transceivers are now synchronized with each other.

## 12 Synchronizing the Sensor and Remote with the Transceiver(s):

### You will need to synchronize the Sensor and the Remote with the Transceiver(s) if:

1. The Sensor and/or Remote were not synchronized with the Receiver(s) at the time of purchase.
2. You get a new or replacement Sensor, Remote or Transceiver.

### Note: The Sensor and Remote must be synchronized with ALL transceivers being used.

Do the following for ALL Transceivers that requires to be synchronized with the Sensor and Remote. All Transceivers must be synchronized at the same time. Placing the transceivers together in the same room will facilitate matters:

1. Plug in the Power Supply to the AC power source and connect to the Transceiver. Press the POWER button on the Transceiver(s). You will hear a beep and the Green LED will light for the Transceiver(s).
2. On the Transceiver(s), press the + and - buttons simultaneously (at the same time) for a few seconds, till you hear a beep and see a Blue flashing LED on the Transceiver(s).
3. While the Blue light is flashing you can synchronize the Remote and the Sensor with the Transceiver(s).
4. To synchronize the Remote, while the Blue light is flashing on the Transceiver(s), press the ON or OFF button on the Remote. The Transceiver(s) will beep once.
5. To synchronize the Sensor, while the Blue light is flashing on the Transceiver(s), short the Sensor by placing a clean key or similar conducting material across the two magnets or across the two snaps on the other side of the Sensor. The Transceiver(s) will beep once.
6. When both the Remote and the Sensor are synchronized, the flashing Blue light will change to a steady Green.
7. If after the sensor and Remote have been synchronized, the flashing Blue light has not changed to a steady Green, an error has occurred in the synchronizing. Please start the process again at step 1 above.
8. When synchronization is complete, press the Power switch on the Transceiver(s) once to turn OFF the Transceiver(s). Pressing the OFF button on the Remote will also turn all Transceivers OFF.
9. Note: You can synchronize the Remote and immediately follow it with the Sensor or vice-versa. At the end of the synchronization the Transceiver(s) should have a steady Green light, and can be turned OFF with the Remote.

Your DryBuddyFLEX Sensor and Remote are now synchronized with the Transceiver(s).

## FCC Warning:

The grantee is not responsible for any changes or modifications not expressly approved by the party responsible for compliance. Such modifications could void the user's authority to operate the equipment.

This equipment has been tested to comply with the limits for a Class B digital device, pursuant to Part 15 of the FCC Rules. These limits are designed to provide reasonable protection against harmful interference in a residential installation.

This device complies with Part 15 of the FCC Rules. Operation is subject to the following two conditions: (1) This device may not cause harmful interference, and (2) this device must accept any interference received, including interference that may cause undesired operation.

## IC Note:

This device complies with Industry Canada Licence-exempt RSS Standard(s). Operation is subject to the following two conditions: (1) this device may not cause harmful interference, and (2) this device must accept any interference received, including interference that may cause undesired operation.

## Information IC:

Cet appareil est conforme a la norme / aux normes RSS sans licence d'Industrie Canada.

Son fonctionnement est soumis aux deux conditions suivantes:

1. ce dispositif ne doit pas occasionner d'interférences nuisibles, et
2. cet appareil doit accepter toute interférence reçue, y compris les interférences pouvant entrainer le fonctionnement indésirable de l'appareil.



# DryBuddyFLEX™

**Affordable Innovations in Bed Wetting and Enuresis Alarm Systems. Raising the Standards for Convenience, Quality, and Value.**

**Enuresis Solutions, LLC**  
51 W. Fairmont Avenue, Suite 2  
Savannah, GA 31406 USA  
912-352-8854  
service@drybuddy.com