

## INSTALLATION GUIDE

Item No.:RR1 BLACK

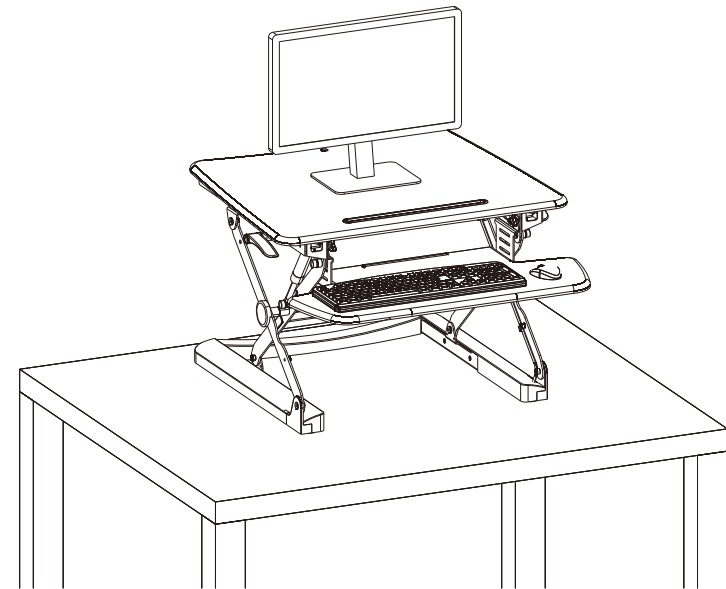

### CAUTION

Please read all instruction carefully before using this product.  
Retain this manual for future reference.  
The specifications of this product may vary slightly from the illustrations and are subject to change without notice.

### CAUTION



Please do not put hands near the supporting bars, as they change during adjusting and may hurt you.

### CAUTION



Please make sure all installed equipment on the table, and not sticking out of the edge, or it may harm or cause damage.

### CAUTION



Adhesive buckle helps to make the cables tidy and clean. Please leave enough length of cable for height adjustment function, otherwise it may cause unexpected lost.

### CAUTION



Please first adjust it to the highest, then remove equipment to avoid harm or damage.

### CAUTION



Please move it by two persons, or parts may collide and cause damage.

## Technical Data

**WARNING** Please do not exceed the maximum bearing weight

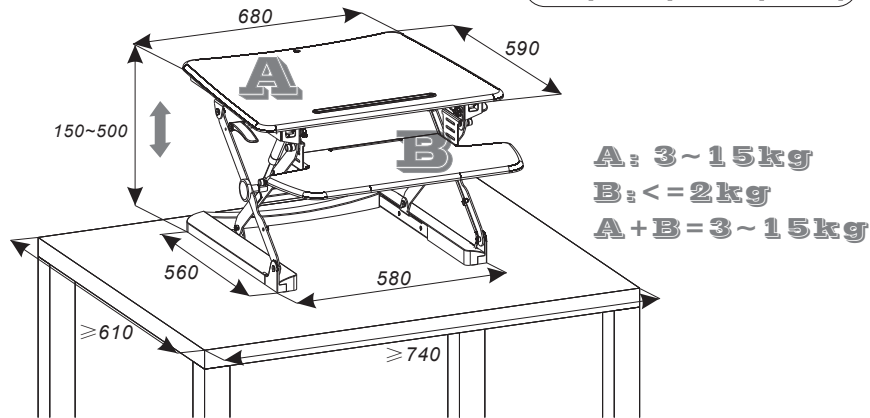
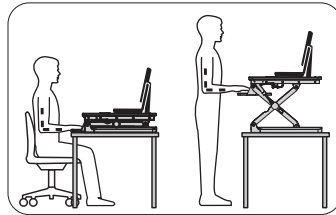

## Accessory Package List

Note: The drawings below are only for reference and may be slightly different with the object, please in kind prevail. Any tools missing or installation problems, please contact the customer service freely.

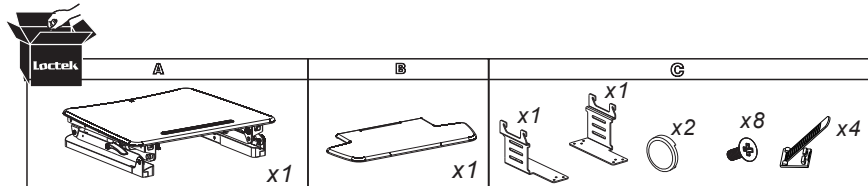

## TOOLS

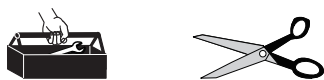

## ASSEMBLY STEP 5

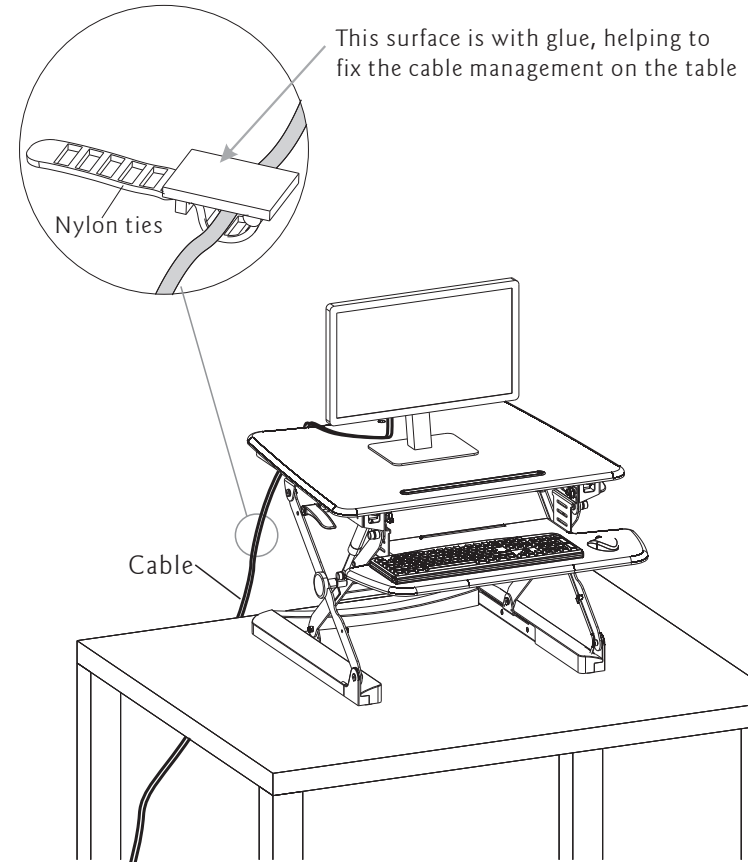

## CAUTION

Adhesive buckle helps to make the cables tidy and clean. Please leave enough length of cable for height adjustment function, otherwise it may cause unexpected lost.

#### ASSEMBLY STEP 4

Please put the devices onto the top of the workstation.

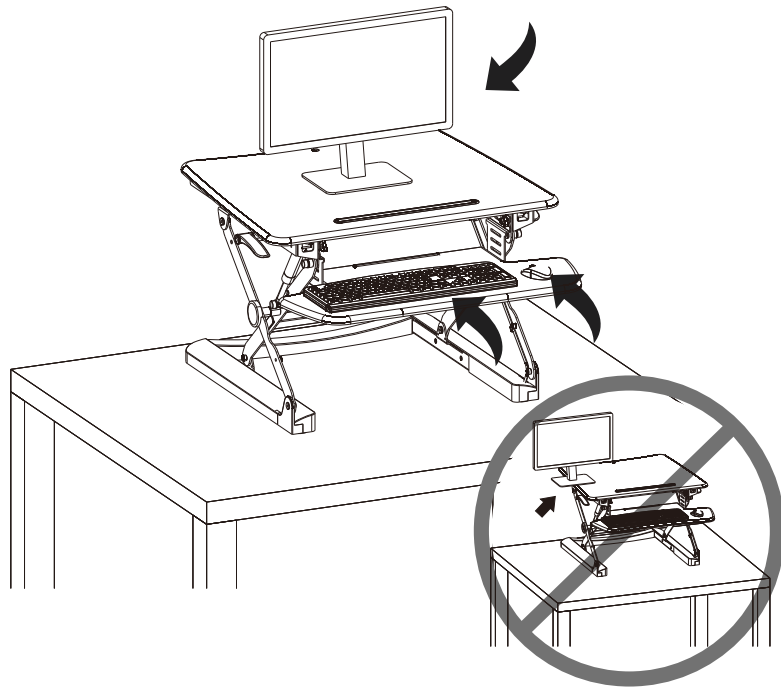

#### ⚠ CAUTION

Please make sure all installed equipments are on the table, and not sticking out of the edge, or it may harm or cause damage.

#### ASSEMBLY STEP 1

Please take the packaging carton apart, take out the product and place it on the table.

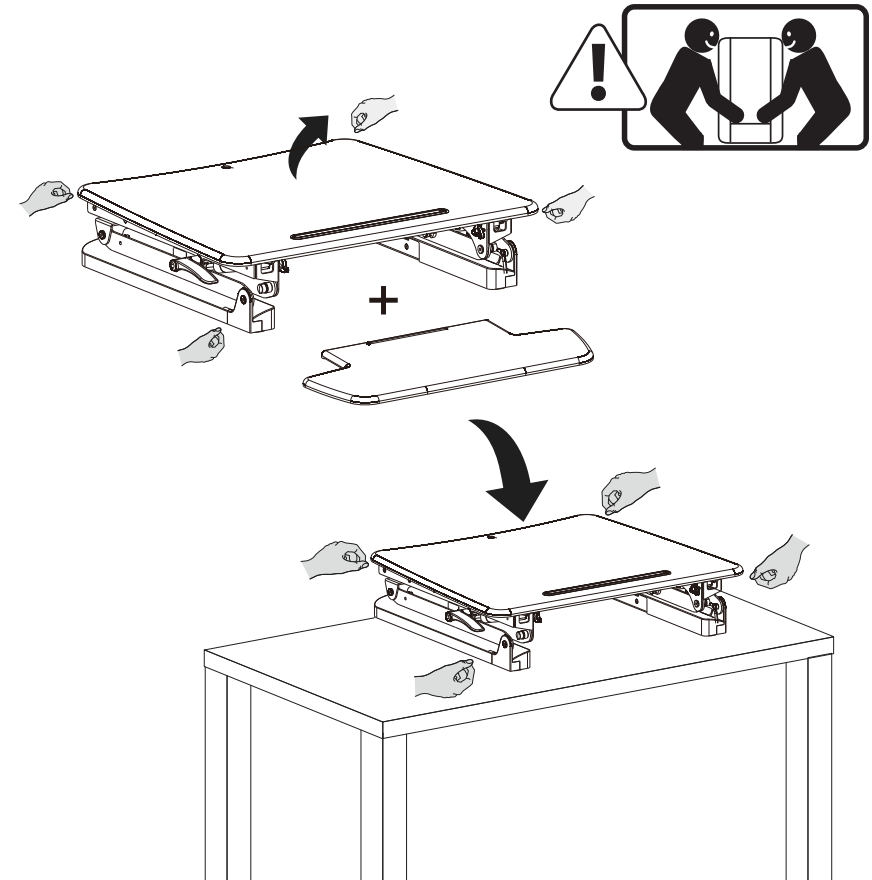

#### ⚠ CAUTION

Please place the product properly according to size of it, or it may harm or cause damage.

## ASSEMBLY STEP 2

- a** : Buckle decorative cover to the connecting arm.
- b** : Connect and fix the junction plate and keyboard tray by 8 screws and use the cross screwdriver to fasten afterwards.
- c,d**: Hang the junction plate on the knob assembled and then tighten the knob.

**Note:** Loosen bolts to make sure the keyboard sits securely before tightening

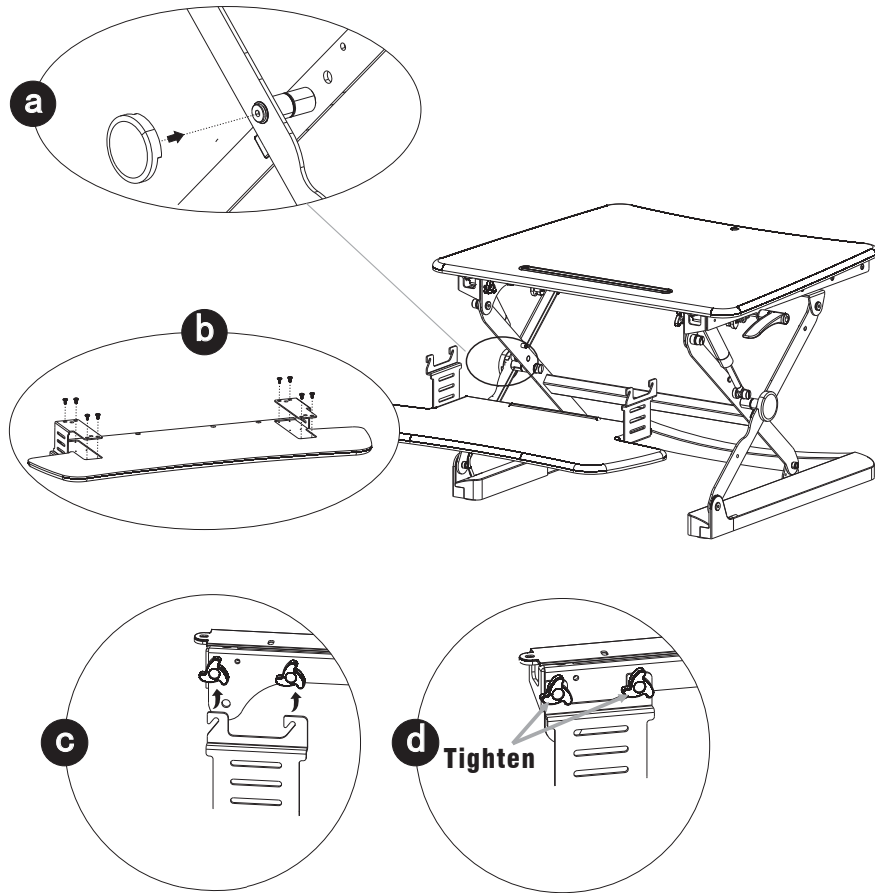

## ASSEMBLY STEP 3

Based on the actual usage, press the handle grips both sides simultaneously, and adjust the workstation to the proper height.

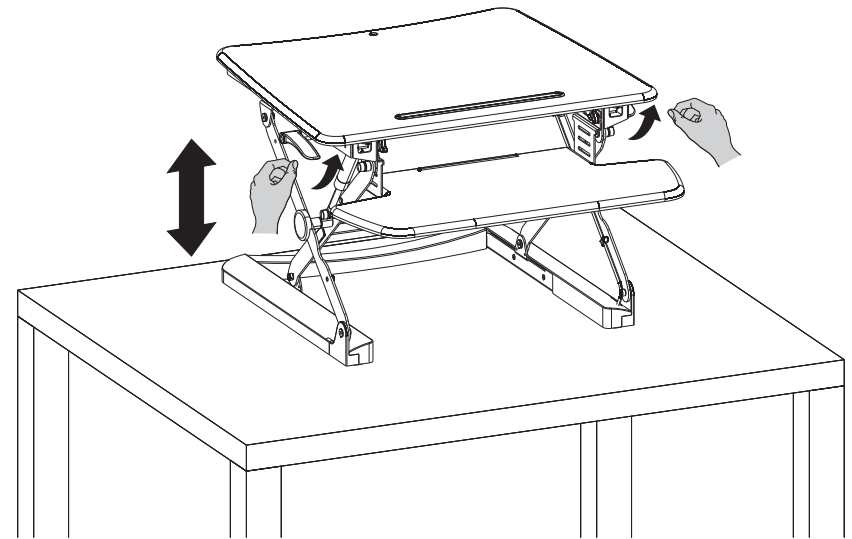

### WARNING

Please do not put hands near the supporting bars, as they change during adjusting and may hurt you.