



PRE-DELIVERY CHECKLIST



□ Delivery:

Please note that the Aqua Tank delivery truck and trailer is LARGE (22m long, 3.1m wide and requires a height clearance of at least 5 metres).

Where practical, our driver may attempt to off-load your tank as close to the prepared site as possible, however this will be at the customer's risk. If delivery cannot be made to your site via truck and trailer – a crane or other equipment hire is at the customer's expense.

If possible, please have someone available onsite to help our drivers off-load your tank.

Our drivers will aim to contact our customer 1-2 hours before delivery to confirm details. They will advise an approximate delivery time. If our driver is unsuccessful in contacting our customer the driver will off-load the tank in a convenient location on site. It will be the responsibility of the customer to then relocate the tank to the required location.

If you have additional delivery information, please contact the Aqua Tank Team on 0800 370 007.

□ Delivery Times:

Please note that all tanks are dispatched from our East Tamaki, Auckland manufacturing plant. Estimated delivery times maybe given, however please consider conditions that may delay these times EG: Weather, Accidents and other deliveries prior to your location.

□ Site Access:

We require suitable access to a flat area to roll the tank off our vehicle. If this requirement is not met then it is your responsibility to arrange suitable lifting equipment to be on site. We will require a turning circle of at least 24 metres or clear access for reversing. Contact us for options.

Prior to delivery check gates, roads, roundabouts, crossings, bridges and overhanging trees on and near your property and advise us in advance of any access problems, including good ground clearance for trailers.

Please note a minimum width clearance of 3.1m is required.

You are responsible for providing safe access by ensuring that the area to unload the tank is level and clear of any building materials, vehicles, or debris or sharp objects that may damage the tank.

□ Organise Assistance:

Our driver may need you to assist in unloading the tank therefore you are required to make sure someone is on site at time of delivery. In the case of larger tanks several able-bodied people may need to be on hand. If this assistance cannot be provided then the availability and operating of lifting equipment is your responsibility.

□ Secure Your Tank:

When your tank is unloaded it must be secured either by filling with water about 100mm deep or with ropes or straps to stop the tank rolling or blowing away. – this is your responsibility. Any damage resulting from failure to secure is not covered by warranty.

□ Location:

Locating your tank in a shady area will help keep the water cool and extend the life of your tank. In deciding where to best place your tank be mindful of proximity to buildings and other structures. All tanks placed in open areas where livestock have access must be fenced (refer to full installation instructions provided with your tank).

□ Preparing your tank site:

If you are preparing your tank site base prior to your tank being delivered, or before you receive the full installation instructions, please note the following:

All tanks from 5,000 litres and above must sit on a flat, level bed of compacted sand or Gap 7 of at least 100mm deep. This bed must be contained with either timber or concrete nib wall and must extend a minimum of 300mm greater than the diameter of the tank. All sharp objects, obstructions and tree roots. must be removed before placing bedding, and check again before placing the tank on this base.

Tanks may be placed on a smooth concrete base pad providing this is constructed such that it will support the tank weight (full of water) without the possibility of cracking or sheering ultimately causing damage or failure of the tank. This occurrence will not be covered by warranty.

In considering your plumbing requirements please be aware all tanks must have overflow pipes fitted that are at least 25mm larger in diameter than any inlet pipe size. These must be piped a minimum distance of 300mm away from the contained base area with clear free drainage to ensure the base material cannot be eroded. Failure to comply with this requirement will void your warranty.

If you are wanting to partly bury your tank, please check with us first.

Full installation and plumbing requirements are covered in the Installation Instructions supplied with your tank, or you can view on our website www.aquatanks.co.nz.

Before carrying out your tank installation please read the instructions and ensure all requirements will be met. Failure to comply will compromise any warranty offered with your water tank.

□ Your Safety:

When trying to move your tank never work alone. Never enter the tank alone.

Please Note: if our driver is unable to successfully deliver your tank because these requirements have not been met a restocking fee and an additional fee to cover the second delivery may apply.

If you have any further questions before we deliver your tank or have problems complying with these requirements please contact us immediately – Phone 0800 370 007



INSTALLATION INSTRUCTIONS

Above ground water tanks

It is important You Read and Understand this Information Before Installing Your Tank

1.Location:

Locating your tank in a shady area may help keep the water cool and your tank cooler. In deciding where to best place your tank be mindful of proximity to buildings and other structures. Owners are advised not to enclose tanks following installation, or install such that sufficient expansion of the tank will be restricted (i.e., do not place tanks hard up against fixed walls, fences, or structures. **Doing so will void your warranty).**

All tanks placed in open areas where livestock have access must be fenced to a minimum of 1.0 metre from the tank to avoid any possible damage to the tank wall. In areas prone to strong or gusty winds (e.g., hilltop locations) stabilising wires must be located through the lifting eyes in the top roof ribs and secured to the ground, particularly where the water level in the tank may vary considerably. **Failure to meet these requirements will void the warranty.**

In areas prone to rabbit or other burrowing animals wire mesh will be required to be erected in a narrow trench around the foundation perimeter to a minimum depth of 600mm. **Failure to do so will void the warranty.**

2.Site Preparation:

Firm flat level ground foundations are required. Ensure the platform for the tank is on solid (compacted) stable free draining ground. The level site must extend a minimum of 300mm greater than the diameter of the tank and must be cleared of any sharp projections such as rocks, stones, or roots. Because ribbed tank walls allow for the weight to be distributed over the largest possible area (31,000 litres = 31 metric tonnes) the tank must sit on a level flat site. If you are placing a smaller tank on an elevated structure (i.e., deck or tower) an engineer's report must be made available to the tank manufacturer for approval prior to installation. Always check with your local council to ensure you meet current requirements.

A uniform 100mm minimum depth compacted sand or Gap 7 bedding must be contained such that it cannot be washed or eroded away. A timber or concrete retaining nib wall is required to retain the bedding. **Failure to do so will void the warranty.**

Where the tank is being placed on sloping ground a flat level area at least 600mm greater than the tank diameter must be excavated and a retained sand bed as described above constructed. The high side of the bank must be retained to hold soil from collapsing against the tank. Drain coil or similar drainage material must be used around the wall face and drain away from the tank site to ensure the tank base material is not eroded. **Failure to do so will void the warranty.**

Tanks exceeding 10000lts may be buried up to a maximum of 700mm (2nd rib) providing all other criteria relating to the installation and site preparation have been met.

Placing the tank on a level concrete pad is acceptable, however the pad must be suitably constructed such that it will support the tank weight (full of water, (1000ltrs = 1000kgs) without the possibility of cracking or sheering and ultimately presenting an uneven surface to the bottom of the tank which could ultimately result in its failure. **This occurrence will not be covered by warranty.**

3.Tank Installation:

Once the tank has been carefully placed in position without disturbing the compacted sand base ensure that there are no visible gaps between the bedding sand and bottom of the tank – if so, fill the gaps.

IMPORTANT:

When using lifting equipment **ensure all tank lifting points are used with an angle of less than 90° at the apex of lifting ropes or chains.** Always lift the tank empty. Failure to do so will cause damage and void the warranty.

(Refer drawing on next page)

Tanks must be empty prior to lifting. Occupational Safety and Health regulations must be used when lifting tanks. All 4 lifting lugs must be used with an angle of less than 90° at the apex

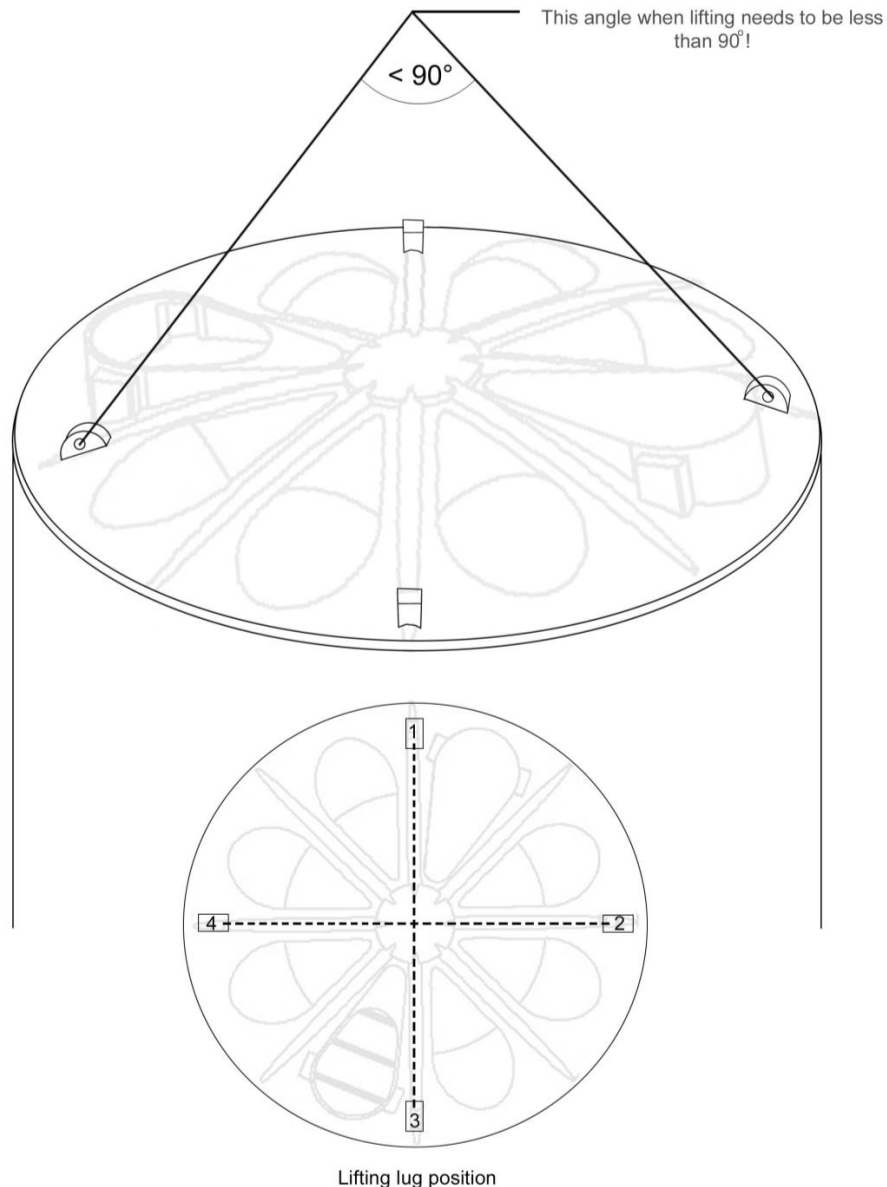

All tanks whether gravity-fed or pressure-fed through a ball valve, float, or other such system must be fitted with an overflow pipe, or pipes to equate to a size greater than 25mm diameter more than the inlet pipe(s) – a minimum of one overflow must be fitted for each inlet pipe. In all installations the overflow pipe(s) must be at a point lower than the inlet pipe(s) to allow the overflow to operate prior to the tank overfilling. **Failure to meet these requirements will void the warranty.**

All inlets and outlets must be cut out with a hole-saw in the designated areas (i.e., in either of the two manhole riser structures). All external pipework must be fully supported. Do not allow the weight of suspended pipework to rest on the wall or roof of the tank without being adequately supported. Do not allow the weight of any pipework to bear on the pre-threaded outlet without being adequately supported (refer instructions on outlet flexible hose). **Failure to meet these requirements will void the warranty.**

All overflow pipes must be plumbed to run water at least 300mm away from the contained base material area to where sand and soil are not likely to be eroded or undermined. **Failure to do so will void the warranty.**

Note: The mesh air vent fitted to the riser on AQ16000, AQ21000, AQ25200 and AQ31000 is **NOT** an overflow. Do not cut any holes or mount any fixture in the tank walls or domed roof other than the designated reinforced areas described above, without prior written approval from the manufacturer. All holes for inlets and overflows must be cut using correct tools (hole-saw). **Failure to do so will void the warranty.**

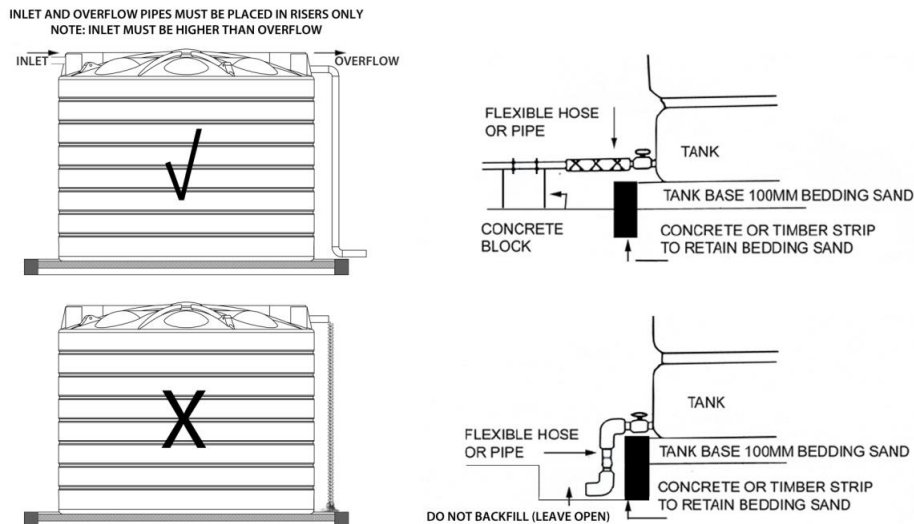

4. Connecting the Tank Outlet:

BSPT (tapered) fittings must be used when connecting to the outlet. It is recommended that a thread sealing tape be used on all threads to avoid leaks and subsequent foundation erosion. Care must be taken when tightening all fittings – do not over tighten (over tightening of tapered thread fittings may result in stripped threads or undue expanded stress on the fittings and/or the tank material). Always secure the pre-threaded tank outlet fitting with a spanner when tightening other fittings into this aperture.

A section of flexible hose must be used between the tank outlet fitting and main feed line away from the tank. Ensure all above ground pipe work is supported level with outlet fitting as shown (refer diagrams below). If buried Alkathene pipe is to be used then a section of flexible pipe must be fitted immediately from the tank outlet before the main line is buried. Any pressure, loading, twisting or bending on the outlet pipe work or tank fitting area must be avoided and may result in tank failure. **This occurrence will not be covered by warranty.**

5. Safety:

Tanks, including domed roof areas are not designed to be walked on other than to enter the man hole entrance, regularly checking inlets, overflows, and breathers are clear of debris or to fit a water vane. Do not enter the tank if working alone. **Do not allow children to climb or play on tanks. . For safety reasons it is recommended that the lid is secured with the screw that is supplied to stop unauthorised entry to your tank**

6. Ongoing Maintenance:

Should the foundation settle slightly when the tank is initially filled with water, and in many cases it will, polyethylene is sufficiently elastic to conform to the ground shape without damage to the tank. However, erosion of the bedding sand from around the wall edges must be replaced and the cause of such erosion eliminated. **This could cause failure of the tank and void the warranty.**

Ensure overflow pipes and breather pipes never become restricted or blocked as excessive pressure build up in the tank could cause failure of the tank. (If you are situated in an area with excessive or extreme rainfall patterns additional overflow pipes and breathers are recommended to help relieve your tank in these instances. **Failure to meet these requirements will void the warranty.**

As part of your regular on-going maintenance programme check for any obvious signs of damage to the tank, foundation, and pipe work and attend to any repairs that may be necessary as quickly as possible. The majority of water tank failures are as a direct result of poor or incorrect installation and/or lack of regular maintenance. It is your responsibility to look after the product and to hold any warranty and purchase information in a safe place. In the event of a problem, you will be asked to provide specific information and photographic evidence as part of a claim process. Failure to supply this information may compromise any claim.

7. Tank Use:

Your Aqua tank is designed for everyday use but in situations where your tank fills and empties on a regular basis such as irrigation or continual cycling it is recommended that an additional breather kit be fitted as failure to do so may void your warranty. An additional Breather Kit is available from your Aqua Tank agent or directly from the manufacturer (0800 370 007). This is also recommended for tanks that have larger than standard outlets i.e., greater than 50mm (2").