

HEN MAX SERIES

HEN30000-35000

PNEUMATIC CLUTCH

Air pressure range (bar)	1~8
Ventilation volume (L/min)	1

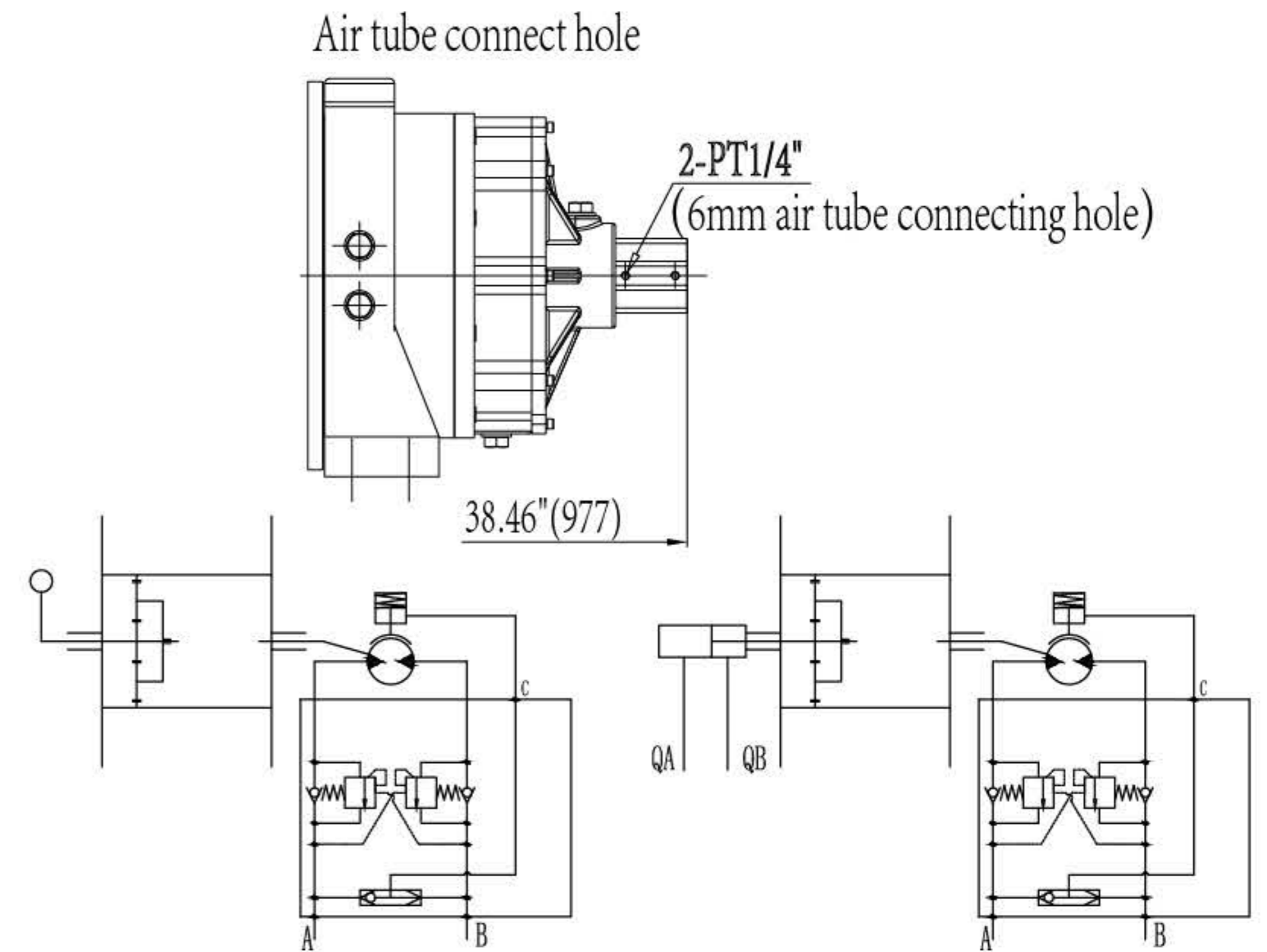
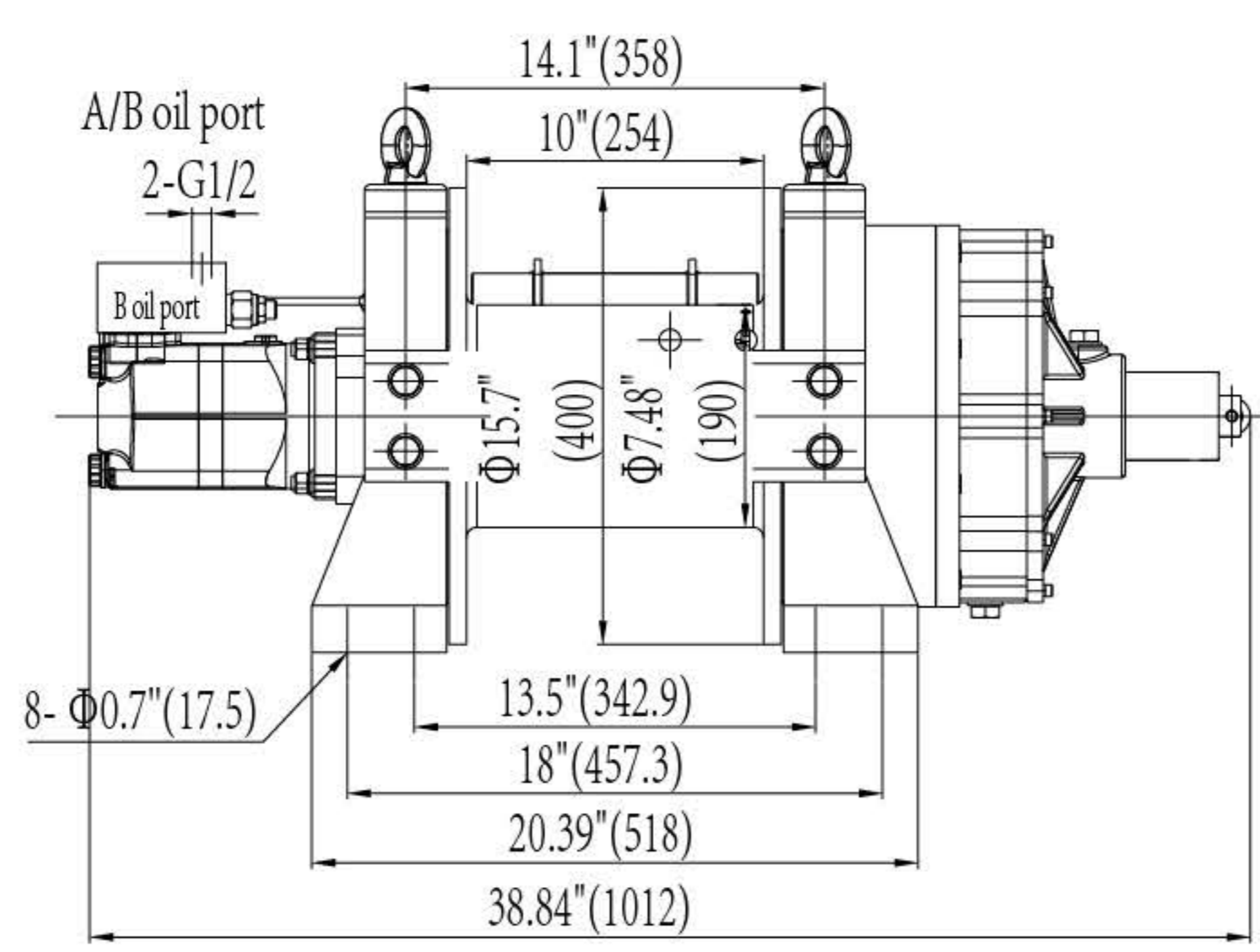
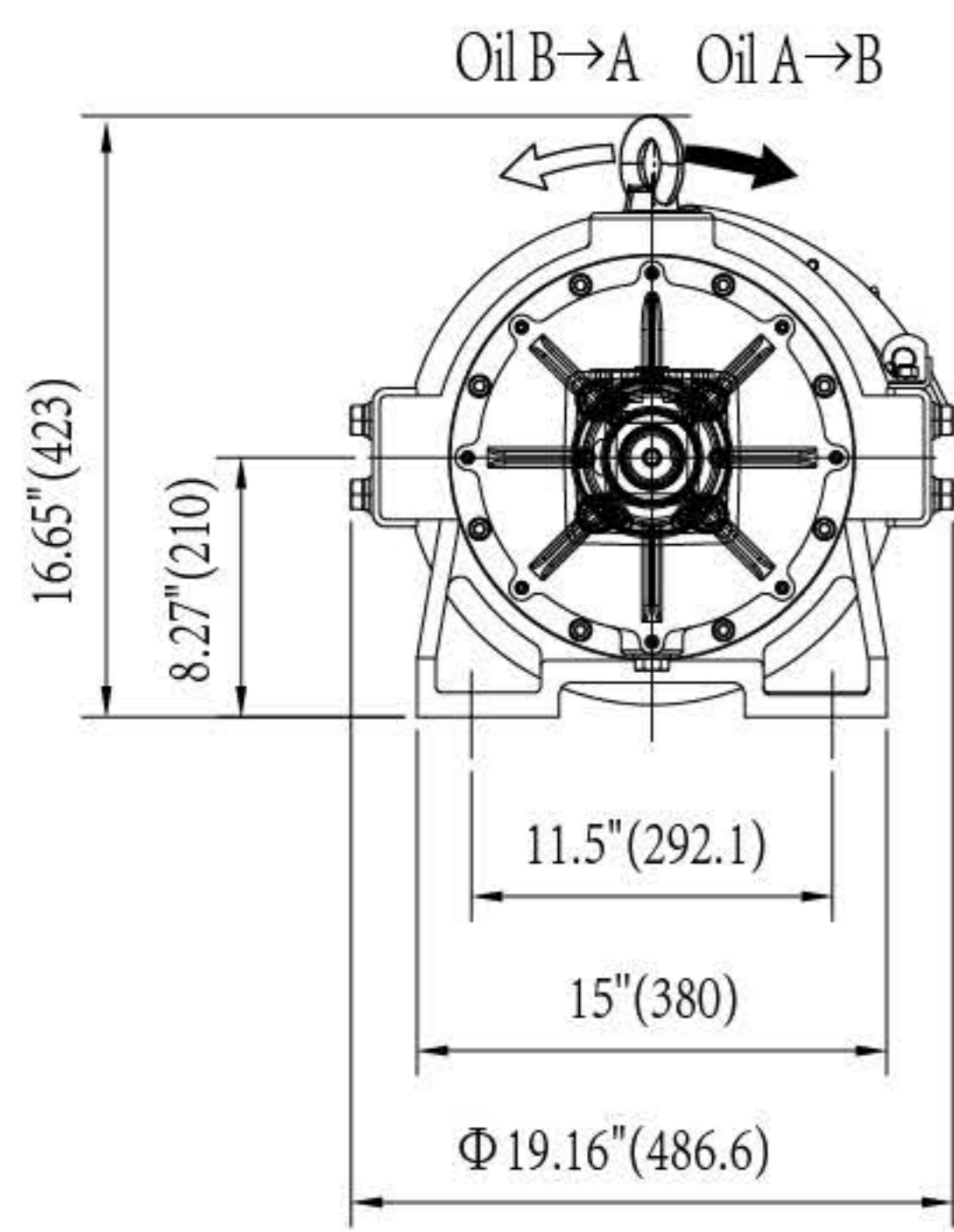

SPECIFICATION

Model	First layer line pull		First layer line speed		Working pressure diff.		Oil flow supply	Gear ratio
	lbs	kg	fpm	mpm	psi	MPa	l/min	
HEN30000	30000	13608	15.1	4.6	2465	17	70	30.39:1
HEN35000	35000	15876	15.1	4.6	2465	17	70	30.39:1

Model	Wire rope dia.		Layer	Wire rope capacity	
	inch	mm		ft	m
HEN30000	$\Phi 3/4''$	$\Phi 18$	5	170.6'	52
HEN35000	$\Phi 3/4''$	$\Phi 18$	5	170.6'	52

PERFORMANCE

Model	Layer of cable	Rated line pull per layer		Line speed		Wire rope capacity per layer	
		lbs	kg	fpm	mpm	ft	m
HEN30000	1	30000	13608	15.1	4.6	22.9'	7
	2	25578	11600	17.4	5.3	52.5'	16
	3	22288	10108	19.7	6.0	91.8'	28
	4	19750	8957	22.0	6.7	134.5'	41
	5	17728	8040	24.3	7.4	170.6'	52
HEN35000	1	35000	15876	15.1	4.6	22.9'	7
	2	29836	13533	17.4	5.3	52.5'	16
	3	26000	11793	20.0	6.1	91.8'	28
	4	23038	10450	22.6	6.9	134.5'	41
	5	20682	9381	25.3	7.7	170.6'	52

NET WEIGHT(WITHOUT WIRE ROPE)

Model	Weight	
	lbs	kg
HEN30000	573	260
HEN35000	573	260

WARNING:

1. Do not use winch to hoist people or objects over people.
2. Do not use clutch under load.
3. Winch system must include a relief valve.

NOTE:

1. Recommended oil flow supply range is 35-90 l/min.
2. Independent oil supply system with relief valve is recommended.