



Pioneer Pro User Manual Contents:

Section 1 Introduction	4
Section 2 Specifications	5
Laser Specifications 2.0	5
Delivery System Specifications 2.1	6
Warranty 2.2	6
Parts List 2.3	6
Section 3 Laser Assembly Instructions	6
Instructions on Unpacking & Dealer Assistance 3.0.1	6
Shipping Container Information 3.0.2	6
Contents of Shipping Container 3.0.3	6
Power Cord Installation 3.1.1	7
Power Fan Switch 3.1.2	7
Laser Key Switch 3.1.3	7
Wireless Receiver Installation 3.1.4	7
Remote Interlock 3.1.5	7
Foot Pedal Battery Installation Instructions 3.1.6	8
Emergency Shutdown Switch 3.1.7	9
Installing the Disposable Fiber Cartridge 3.1.8	9
Settings 3.1.9	9
Visual Assembly Aides	10-13
Facility and Environmental Considerations 3.2	14
Power Requirements 3.2.1	14
Heating and Ventilation 3.2.2	14
Combustible Chemical Gases 3.2.4	14
Vacuum and Filtration 3.2.5	14
Access and Visual 3.2.6	14
Channel Programming 3.2.7	14-15
Laser Frequency 3.2.8	16
Section 4 Safety Considerations	16
Food and Drug Administration 4.0	16
Wireless Technology 4.1	16
Statutory Licensure 4.2	17
OSHA Provisions 4.3	17
Laser Safety Program 4.4	17
Continuing Education 4.5	17
In-Office Safety Issues 4.6	17
Lighting 4.6.1	17
Safety Eyewear 4.6.2	18
Test Firing 4.6.3	18
Power Changes with Fiber Changes 4.6.4	18
Fiber Preparation 4.6.5	18
Laser Sinage 4.6.6	18
Sharps Disposal and Sponge Disposal 4.6.7	18
Plume Evacuation 4.6.8	18
Key Switch and Mode Selection 4.6.9	18
Safety Education 4.6.10	18
Laser Security 4.6.11	18
Emergency Shutdown Options 4.6.12	19
Hard Tissue Procedures 4.6.13	19
ANSI Standards 4.7	19

Section 5 Operating the Laser	19
Standby and Ready Status 5.0	19
Continuous Wave (CW) Mode 5.1	19
Pulsed Energy Mode 5.2	20
Tissue Response to Laser Energy 5.3	20
Fiber and Handpiece Care 5.4	20
Warning Do Not Autoclave 5.5	20
System Procedures 5.6	21
Treatment Area Requirements 5.6.1	21
Foot pedal 5.6.2.....	21
Fiber Cartridge 5.6.3.....	21
Fiber Preparation 5.6.4	21
Emergency Shutdown Button 5.6.5.....	21
Key Switch 5.6.6	21
Setting Parameters 5.6.7.....	21
Power Selection 5.6.8.....	21
Selecting Programs 5.6.9.....	21
Aiming Beam 5.6.10	22
Examine the Fiber Tip 5.6.11	22
Clinical Procedures 5.7	22
Self Diagnostic and Monitoring 5.8.....	23
Section 6 System Components	24
Preparation, Care and maintenance 6	24
Disposable Fiber Cartridge 6.0.....	24
Replacing the Fiber Cartridge 6.0.1	24
Fiber Preparation 6.1	24
Jacket 6.1.1	24
Cladding 6.1.2.....	24
Quartz / Silica Fiber 6.1.3	24
Stripping the Fiber 6.1.4	25
Cleaving the Fiber 6.1.5.....	25
Initiating the Fiber 6.1.6.....	26
Fiber Disinfection 6.1.7.....	26
Laser Maintenance 6.2.....	26
Chassis Disinfection 6.2.1	26
Calibration 6.2.2.....	26
Handpiece Preparation 6.3	27
Autoclavable 6.3.1.....	27
Handpiece Components 6.3.2.....	27
Rocker Switch 6.3.3.....	27
Disposable Tips 6.3.4.....	27
Prepare the Fiber 6.3.5.....	27
Mounting the Tip 6.3.6.....	27
Section 7 Labels, Signs, Warnings and Manufacturer's Information.....	28
Federal Compliance 7.1.....	28
Danger, Warnings and Caution 7.2 – 7.13.....	28-29
Nominal Ocular Hazard Distance 7.11	29
Section 8 Servicing	29
Warranty Policy 8.1	29
Repairs and Returns 8.1.2	30
FDA and Laser Standards	31
Troubleshooting	32

SECTION 1 – INTRODUCTION

Pioneer Lasers, LLC has developed the Pioneer Pro, the most practical and least invasive technology available for performing soft tissue surgical procedures. Pioneer Pro reduces wound healing time^[1] and lets you perform procedures in a conservative, less traumatic manner. The laser's energy is delivered through a 400 micron silica filament, giving you control over the depth and width of areas being excised while providing simultaneous hemostasis. Weighing 5.5 pounds, the Pioneer Pro is controlled by a wireless foot switch that offers maximum flexibility in unit positioning. *Footnote [1]: WOUNDS A Compendium of Clinical Research and Practice:Volume 16, Number 12:December 2004:Papillion etal*

The Pioneer Pro is FDA cleared for use in dental and oral procedures on soft tissues for the actions of removing lesions, making excisions or incisions, vaporizing and ablating tissue, and for hemostasis.

Device Features:

- Wireless Foot Switch, maximum flexibility in placement
- 400 Micron Fiber Tip, precise target area
- Easy to operate intuitive program
- Lightweight easy to move, 5.5 pounds
- Small size, easy to position 5.5" X 6.25" X 8.75"
- Retractable fiber delivery system gives you freedom to position yourself
- 810 nm wavelength for soft tissue surgery, reduces healing time^[1]
- Aiming Beam 630nm wavelength provides illumination to working site
- Adjustable power .1 to 5.0 Watts allows extraordinary flexibility in procedures and uses
- Balanced ergonomic pen like fiber optic delivery

The major components of the Pioneer Pro are semiconductor "chips" that are commonly referred to as AlGaAs. They are activated or "pumped" by passing an electrical current through the diode to produce an elliptical shaped display of monochromatic light that can be focused into a very small point and placed into the delivery fiber. Pioneer Pro generates energy in two wavelengths, 810 nm and 630 nm. The energy produced at 810 nm is used as a soft tissue surgical laser; it is invisible non-ionizing radiation that does not create changes in cellular DNA. The energy produced at 630 nm is a substantially lower energy level and is used to illuminate the site as an aiming beam.

This device is intended for use only by a licensed and trained dental professional in a controlled dental operatory environment. This device is intended for use for procedures of removal of lesions, excision, incision, vaporization, ablation, hemostasis, and photocoagulation.

CAUTION:

US Federal law restricts the device to sale by or on the order of a licensed professional.

SAFETY

Laser safety is of paramount importance and each office should quickly develop and implement a laser safety program and identify a "Laser Safety Officer" to be responsible for the laser. The LSO's duties include management of the laser and all accessories as well as training office personnel in all aspects of laser safety.

ALWAYS test fire the laser away from tissue before using it on a patient. The doctor, staff, patient and anyone present in the operatory should be wearing the appropriate safety eyewear whenever the laser is being operated. Strict adherence to protocols for safe laser use is essential.

SECTION 2 – SPECIFICATIONS

2.0 Laser Specifications

Weight	5.5 lbs
Dimensions in inches (H x W x L)	5.5" x 6.25" x 8.75"
Laser Classification: (Per IEC 60825)	
Laser Diode	Class 4 Laser Device
Wavelength:	
Laser	810 nm ± 20nm
Aiming Beam	630 nm – 660 nm ± 15 nm
Beam Divergence	13 degrees ± 1 degree
Power Range	100 mW to 5.0 Watts
Hertz Rate in Pulsed Mode - fixed	10.0 Hz
Pulse Duration - fixed	0.05 seconds
Duty Cycle	
Pulsed Mode	50%
Continuous Wave	100%
Aiming Beam (3 mW)	Yes
Audible Notification	Yes
Visual Notification	Yes
Power Requirements	110 – 120 VAC @ 60 Hertz 220 – 240 VAC @ 50 Hertz
Amperage	1.5 Amps @ 110 – 115 V AC 0.75 Amps @ 210 -230 V AC
Cordless Foot Pedal:	
Frequency	2.4 GHz
Battery	9 volt Lithium

2.1 Delivery System Specifications

2.1.1 Quartz Silica Fiber

1 Cartridge - Approximately 20' (6 meters) of Silica fiber

Fiber Diameter 400 microns

Autoclavable No

2.2.2 Handpiece

Autoclavable 2

2.2.3 Tips for Handpiece

Disposable 20 per pack

2.2 Warranty

Laser Unit 2 years parts and labor

SECTION 3 – LASER ASSEMBLY INSTRUCTIONS

3.0 Removing the Laser from the Packaging

3.0.1 – Instructions on Unpacking & Dealer Assistance

Do not attempt to unpack the laser and install the various components without reading the manual first.

If you are unsure about any aspect of the assembly, call your authorized dealer.

3.0.2 – Shipping Container Information

Please keep the shipping box. If you need to return the laser, repack it in the original box.

3.0.3 – Contents of Shipping Container

- 1 Pioneer Pro Unit with 400 Micron Fiber Cartridge System
- 1 Fiber Stripper Tool
- 1 Fiber Cleaving Tool
- 3 Protective Glasses
- 2 Package (20) Handpiece Tips straight
- 1 Package (20) Handpiece Tips 60°
- 2 Handpieces, autoclavable
- 1 Laser Key
- 1 Wireless Foot Pedal
- 1 Wireless Receiver
- 1 9 Volt Battery
- 1 Power Cord
- 1 Pioneer Pro Owner's Manual
- 1 Laser Safety Sign

3.1 Assembling the Laser

3.1.1 Power Cord Installation (see Figure 3.0 on page 10)

- Remove the power cord from the Pioneer Pro package
- Plug the power cord into the appropriate receptacle on the back of the laser
- To prevent power surges due to electrical storms or spikes in line voltage, use a power strip with a circuit breaker or unplug the laser when you are not present
- Plug the power cord into a 110 Volt AC outlet rated at 60Hz.

3.1.2 Power/Fan Switch (see Figure 3.0 on page 10)

- The power/fan switch for the laser and fan is the first item you turn on
- The switch is located on the rear panel of the laser near the lower left hand corner

3.1.3 Laser Key Switch (see Figure 3.1 and 3.1a on page 10)

The laser key switch is the main safety switch for your laser.

- Place the laser key into the key receptacle located near the lower right corner on the front of the laser
- Check the key switch by turning the key clockwise approximately 1/4 of a turn
(This is the (ON) operating position for the key)
- The fan will start when the power/fan switch is on and the key is turned on
- Prior to leaving the office check to see that the key switch has been turned off and the key removed and stored in a safe place

3.1.4 Wireless Receiver Installation (Figure 3.0, Figure 3.3 and Figure 3.4 on page 11)

- Locate the wireless transmitter receptacle on the back of the laser
- Insert the wireless transmitter adapter into the marked receptacle on the back of the laser
- Make sure it is securely locked
- An extra 9 volt Lithium battery should be kept in your office inventory as the foot pedal battery should be replaced every 100 hours of continued operation

3.1.5 Remote Interlock

The Pioneer Pro is equipped with a Remote Interlock Jack. The Remote Interlock Jack is provided so that a clinician may install the laser in a dedicated laser treatment room such that the laser will be interlocked with the entrance door of the room. In such an interlocked installation, the laser would shut off anytime the door is opened to protect the eyes of the person who is entering the room. It is recognized that such installment is not facilitated or practical in many operatories or clinics. To that end, the Remote Interlock is available to any practitioner that requires it. The Remote Interlock Jack is located and clearly labeled on the rear of the laser. The mini phono jack is wired in the normally closed position; meaning that no further action is required to operate the laser without the interlock loop. If the interlock loop is desired you may purchase the loop from a local electronics store. You need only inform the local electronics store that you require a mini (1/8") mono-phono jack wired into a normally closed momentary switch and select the switch design that best suits your needs. To install the loop, install the switch on the door and simply plug the mini phono jack into the Remote Interlock Jack on the rear of the laser.

3.1.6 Foot Pedal Battery Installation Instructions

1. Make sure the laser is completely turned off before placing the battery in the foot pedal

2. Place the pedal face down on a hard, clean surface (Figure 1)



Figure 1

3. Use a philips-head screwdriver to remove the two screws securing the battery cover. Turn the screwdriver counterclockwise until the screws comes out completely (Figure 2)

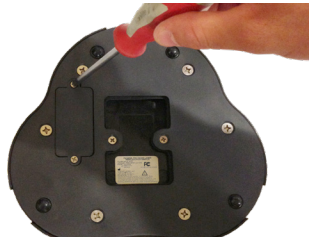

Figure 2

4. Push down on one end of the battery cover while simultaneously lifting up on the other end to remove the battery cover (Figure 3)



Figure 3

5. Detach the existing battery from the connector. Do not pull on the wires to detach the connector. Lift up on the black connector itself.

6. Remove the battery from its packaging and attach the battery to the terminal (Figure 4)



Figure 4

7. Place the battery in the well with the connector to the same side as the wire leads emerge from the housing (Figure 5)



Figure 5

8. Replace the battery cover

9. Replace the screws. Turn the screwdriver clockwise to tighten the screws. The screws are sufficiently secure once they no longer turn with gentle finger-applied force. Do not over-tighten. (Figure 6)

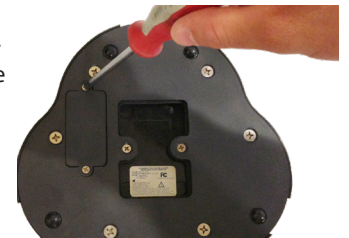

Figure 6

NOTE: It is recommended to use a 9 volt Lithium battery to power the cordless foot pedal. This type of battery has been tested to last for over 100 hours of foot pedal operation. When the battery voltage begins to drop, the foot pedal will begin to beep, signaling that you have approximately 2 hours of operating time left before the battery life is completed.

NOTE: A 9 volt alkaline battery may be used; however the life expectancy of an alkaline battery is less than 35 hours of operating time.

3.1.7 Emergency Shutdown Switch (see Figure 3.5 and 3.6 on page 12)

If the shutdown switch is locked down, the laser will not turn on. Before you can activate the laser, you must first check to see if the emergency shutdown switch has been depressed prior to shipment and locked in the off position.

- The switch is the red button located on the top of the laser.
- Release the switch by grasping it between your thumb and index finger, and gently depress it as you turn the button 1/4 turns clockwise.
- You will feel it “click” or release and the spring loaded button will pop back up.
- The display on the control panel should now illuminate.
- If the cartridge lock plate is not fully engaged, this will also prevent the display from illuminating.
- If you find the display is still not operational, check all attachments, keys and switches to see that they are securely installed and that you have an active wall plug for electricity.
- If the laser can not be activated, please contact the manufacturer.

3.1.8 Installing the Disposable Fiber Cartridge

The unit comes with a disposable fiber cartridge installed with 20 feet of fiber. The fiber cartridge may be removed and replaced when the optical fiber has been consumed. A white mark on the fiber indicates 6’ of fiber remaining on the cartridge. At this point, a new fiber cartridge should be ordered.

Note: Retain the cartridge lock, do not discard.

To install a new cartridge, carefully remove the new fiber cartridge from the packing.

- Make sure the laser is switched off and the power cord has been unplugged.
- Remove the cartridge lock by pressing on the tab and sliding the lock plate to the side.
- While grasping the fiber connector, press in and rotate counter clockwise. Then pull the connector straight back.
- Pull the cartridge straight up, out of the bay.
- Using a completely dry air spray or canned air, lift down the black flap and blow air into the connector receptacle in the side of the housing. This will remove any dust particles that may be present.
- Slide the new cartridge down into the bay and press it firmly in place. (FIGURE 3.8 and 3.9 and 3.11)
- Remove the plastic cap from the end of the connector. CAUTION: Avoid placing your finger on the terminal end of the connector.
- While opening the door on the laser aperture with one hand, insert the end of the new fiber into the laser aperture (Figure 3.13)
- Be careful to align the slot on the fiber end with locking hub aperture. (FIGURE 3.14)
- Once inserted, turn the fiber locking hub to the right (clockwise) to lock the fiber securely into the connection.
- Once connected, replace the cartridge lock to secure the fiber cartridge. The laser will not operate until the lock is firmly latched in place.
- Turn the key switch and power/fan switch to the “on” position
- Test your power connection by advancing the fiber, using the rocker switch on the top of the cartridge. Depress the switch at its most anterior point to see if it moves the fiber forward.
- Select a low power to check transmission of energy (1 Watt – 1.5 Watt)
- Put on safety eyewear
- Place laser in “Ready” mode
- Depress the foot pedal to activate the laser while holding the fiber approximately 2-4 mm away from a piece of paper with printing on it.
- Aim at the printing, the paper will begin to burn in 1-2 seconds
- You should be able to see the aiming beam on the paper and the fiber tip should produce enough heat to let you know it is installed properly and the fiber is sound.
- You do not want to use an initiated fiber for this check because the energy would stop at the tip.

3.1.9 Summary: Laser Assembly Instructions

1. Attach the laser’s power cord and place the plug into the wall receptacle.
2. Attach the foot pedal – wireless receiver.
3. Install the foot pedal battery.
4. Attach remote interlock, if desired.
5. Check the emergency shutdown switch to see that it has been released.
6. Install the fiber cartridge and attach the fiber to the ST connector and lock the locking hub.
7. Place the key into the key switch receptacle (Figure 3.1a) and turn the key to the right. The console should light up.
8. The light on the console indicating the operating status should be in the standby mode.

NOTE: When the power cord is plugged in, the fan/power motor switched on, the wireless foot pedal receiver attached and the emergency shutdown released, the key will turn the laser on.

Visual Assembly Aides

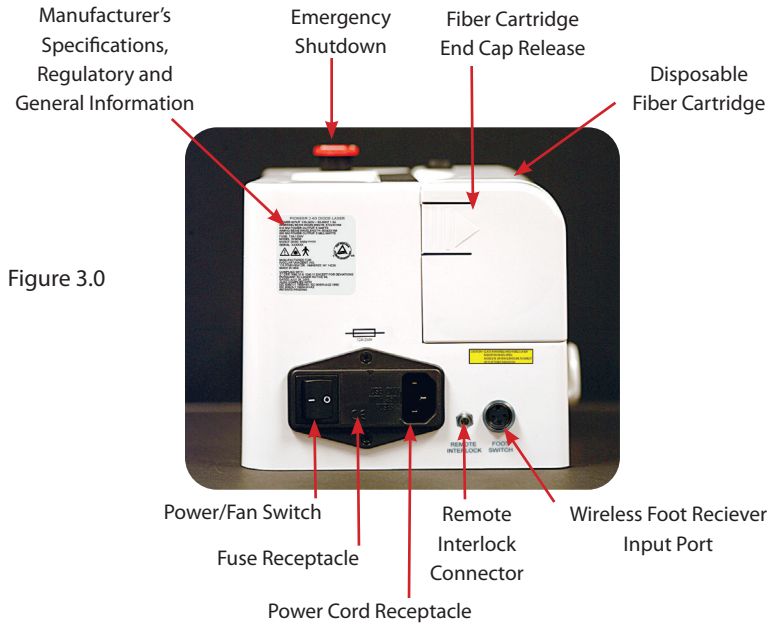

Figure 3.0

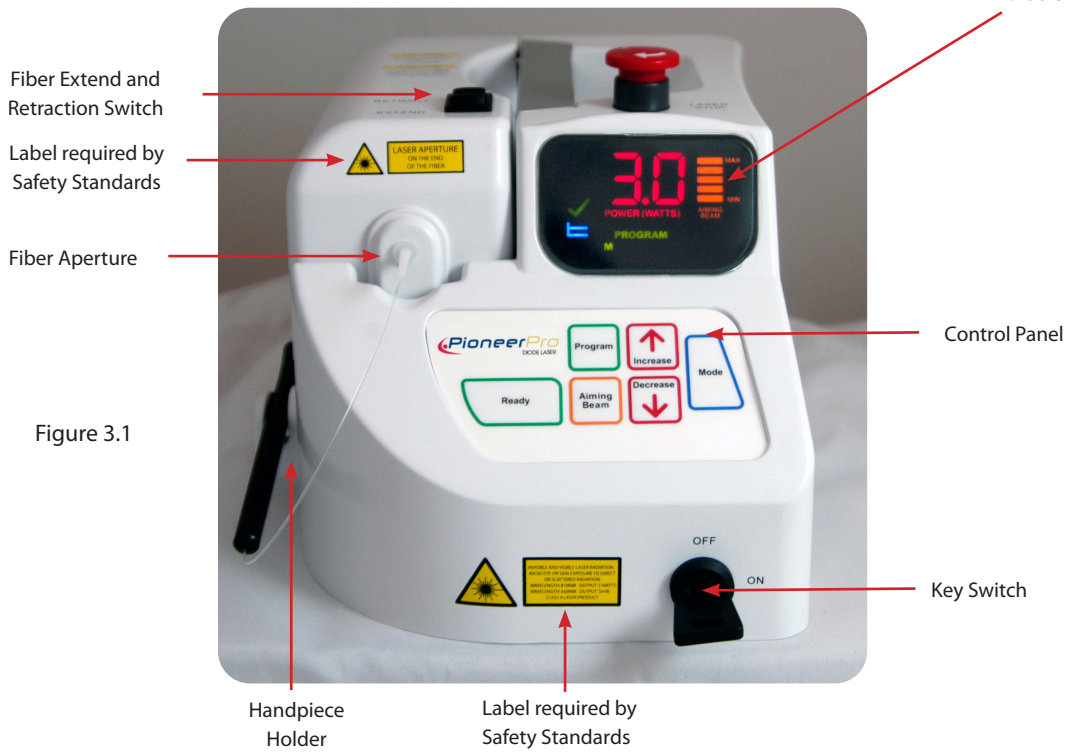
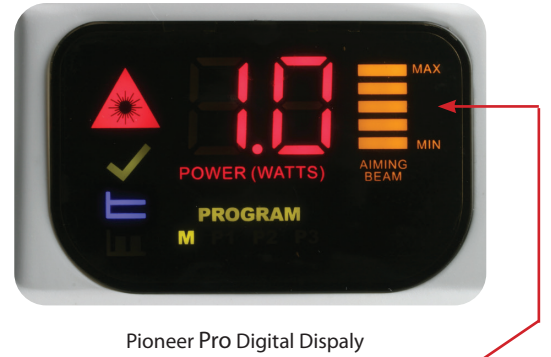
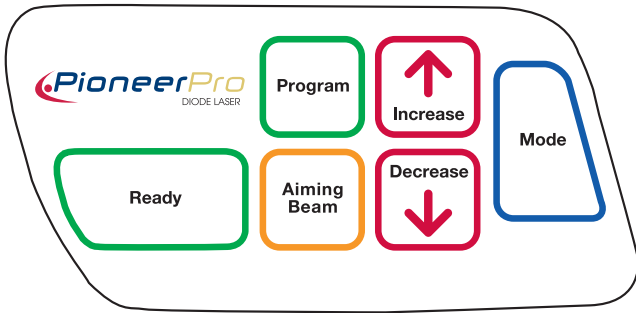

Figure 3.1



Figure 3.2 - Control Pad Settings



Mode: Press this key to select Continuous or Pulse mode.

Aiming Beam: Use these to adjust the aiming beam power.

Program: Press this key to select either manual (M) or one of three user defined programs (P1, P2, P3). Each program will save the parameters – working beam, aiming beam and mode of operation.

The settings can be changed as desired for any of the program modes. To set the user defined program modes, choose P1, P2 or P3, set your preferred settings and push the ready button. Upon activating the ready button, the new settings will be retained.

Increase and Decrease: Use these to adjust the power setting from 0.1 to 5 watts. Hold the desired key to rapidly change the value.

Figure 3.2a - Display Indicators

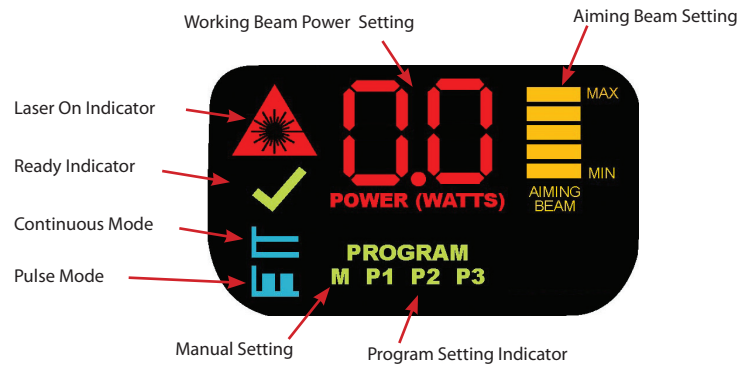

Laser On: This illuminates when the foot pedal is depressed, this indicates that the working beam (810 nm) energy is being emitted.

Ready Indicator: This illuminates when the READY key is pressed. It will blink for 3 seconds, and then remain steady. Once it is steady on, the aiming beam will be activated.

Continuous and Pulse Mode: This illuminates when the unit is in continuous mode. Use the MODE key to toggle back and forth between Continuous and Pulse.

Working Beam Setting: Indicates the working beam power output setting.

Adjustable Aiming Beam: The Pioneer Pro is actually two lasers in one, the infrared 810 nanometers wavelength laser which performs the actual treatment of the soft tissue and the 630 nanometers “laser pointer” which illuminates the direction where the laser will be used. Each bar represents 20% of maximum intensity. Thus 0 bars means the aiming beam is shut off.

Program Setting Indicator: Shows the current program mode that is selected. Pressing the PROGRAM button will cycle through the programs left to right, then back to manual “M”.

Figure 3.3 - Wireless Foot Switch Receiver Port

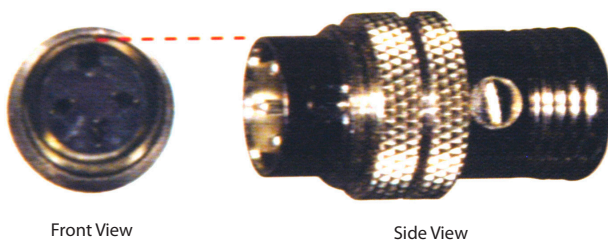

Align the lip on the proximal end of the wireless receiver with the notch at the top of the input port.

Figure 3.4 - Wireless Foot Switch



Check The Emergency Shutdown System

1. Depress the red button on the top of the system to shutdown (feel the click), the unit is OFF in the down position Emergency Shutdown Switch.
2. Depress slightly and turn right ¼ of a turn to release. The emergency stop will pop up and the LED screen will light.



Figure 3.5 Shutdown

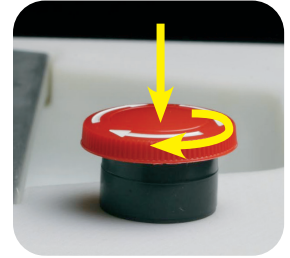

Figure 3.6 Release

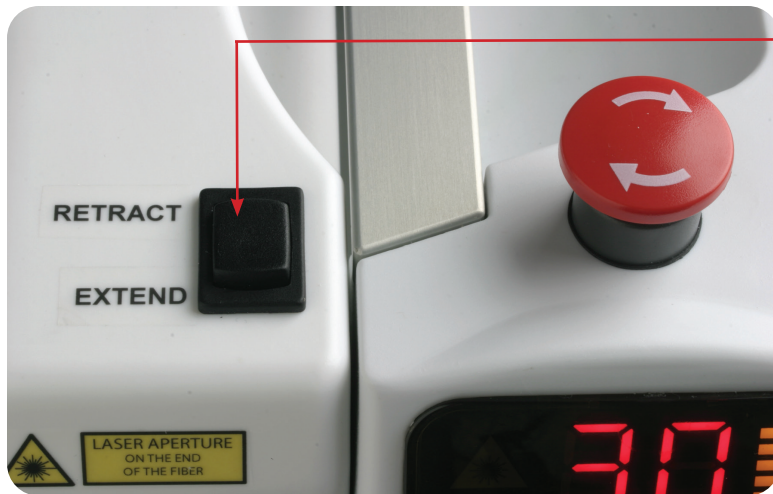

Figure 3.7 Top View

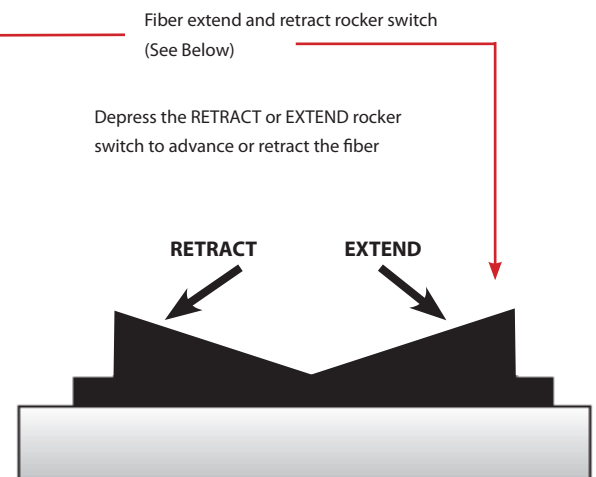

Figure 3.7a Rocker Switch Activation

Receiver for the Fiber Cartridge end cap locking device

Laser Aperture with ST Connection:

The proximal end of the fiber inserts here and is locked by turning the locking hub to the right

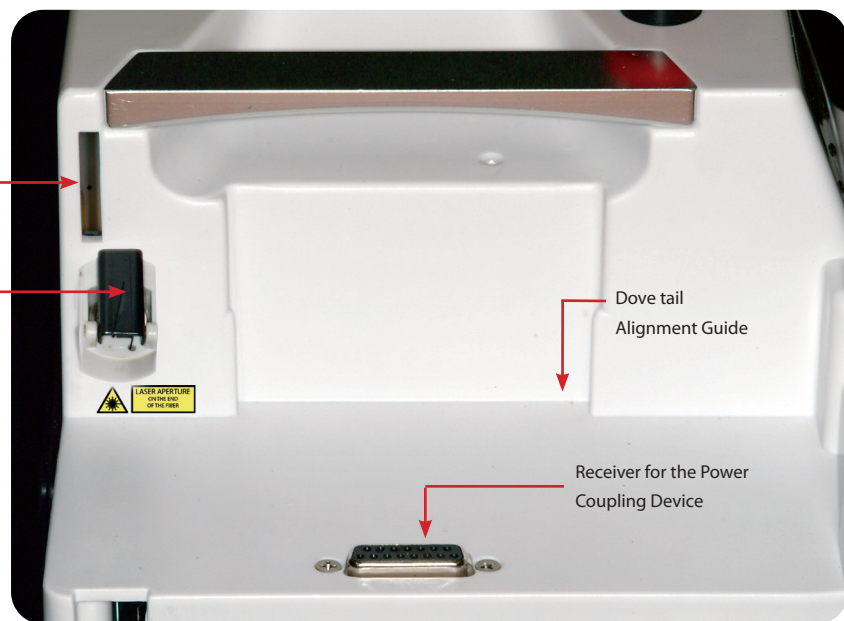

Figure 3.8 Laser Aperture (ST adapter) and power receiver for the power coupling device on the base of the cartridge.

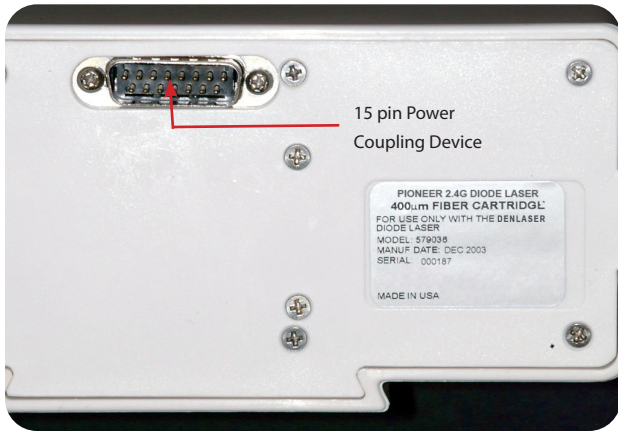

Figure 3.9 Base of the Fiber Cartridge and the 15 Pin Power Coupling Device

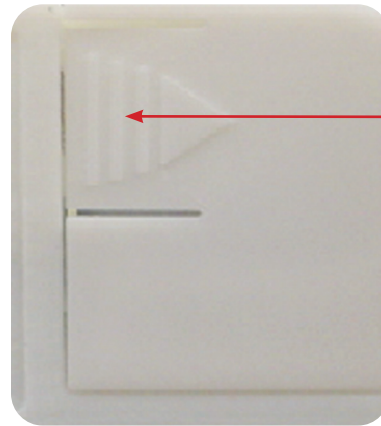

Figure 3.10 Removable End Cap of the Fiber Cartridge



Figure 3.11 Disposable Fiber Cartridge without the End Cap

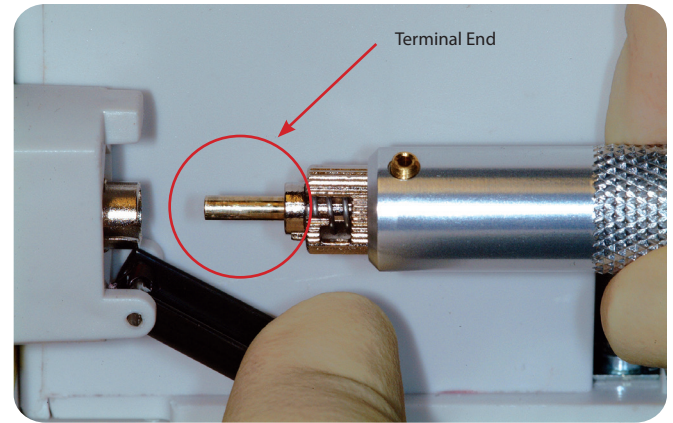

Figure 3.12 Fiber exit from the Disposable Fiber Cartridge

The terminal end of the fiber extends from the internal wall of the fiber cartridge and must be attached to the laser by inserting it into the Laser Aperture (ST adapter).

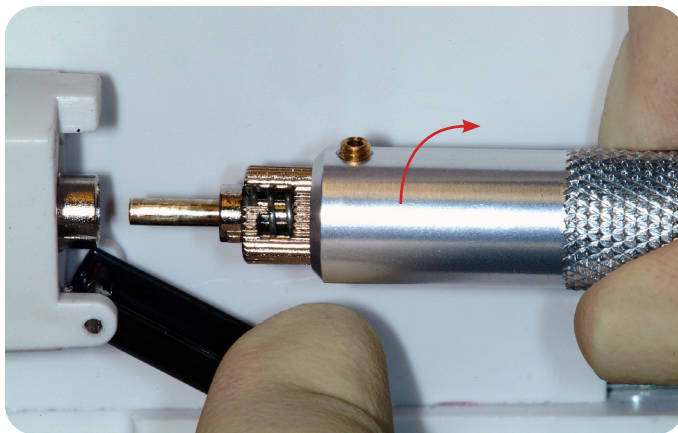

Figure 3.13 Locking Hub

Once it is inserted into place, it is locked by turning the locking hub approximately 1/8 turn to the right.

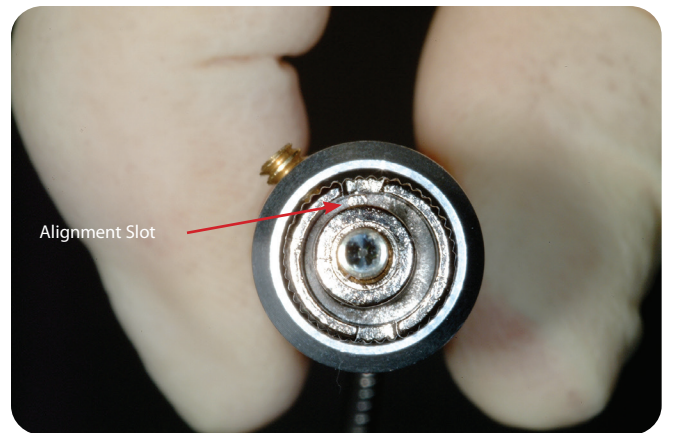

Figure 3.14 Alignment Slot - Frontal View

3.2 Evaluating the Facility and Environmental Considerations (United States)

In order to insure the safe use of the laser in your facility, please check to make sure that the proposed location has the following:

3.2.1 Power Requirements

110 – 2400 V AC±10 %

3 Amps

Frequency range 45-63 Hz

9 volt Lithium battery

3.2.2 Heating and Ventilation

The room where the laser is used should have good cooling and heating system so that the laser can be operated within the optimum range of 20° - 30°C (68° - 86°F). Avoid storing or transporting the laser in temperatures below 0° Celsius (32° F).

3.2.3 Lighting

Overhead lighting should provide enough illumination to see properly, accessory lighting devices may also be used.

3.2.4 Combustible Chemical and Gases

All gases that are combustible or support combustion and are used in the operatroy area where the laser is in use must be turned off during the procedure. Cleaning supplies or other flammable chemical compounds should be stored in an area away from the surgical site in order to avoid possible combustion.

3.2.5 High Speed Vacuum Systems

Plume evacuation is a priority when vaporizing tissues, use of a high volume vacuum system and high filtration masks that are suitable for virus and bacterial control should be used at all times.

3.2.6 Access and Visual

Access to the treatment area should allow the team to restrict entry while the laser is in use. There should be a Laser In Use Safety Sign placed in a designated area adjacent to the entry into the treatment area. (See Figure 7.1)

3.2.7 Channel Programming Procedure

There is no concern if two or more Pioneer Pro lasers in the same office are set to the same channel. Each laser and its corresponding pedal have additional programming that is unique to the pair. The pedal from one laser will not activate any other laser. However, if units on the same channel are near each other, the transmissions from one may interfere with the signal from another and thus prevent the second laser system from operating properly. It may become necessary to change the channels on one or more units to minimize interference.

Channel Programming Procedure

1. Make sure the unit is off before going forward with the programming procedure. Do not press the foot pedal for at least 30 seconds before proceeding.

2. Before turning the unit on. Press and hold PROGRAM.

3. While holding the program key down, turn on the unit, the display will briefly show “=P”, then show “c1 for channel 1. “c2” for channel 2, up to channel 8 (depending on what programmed channel the unit is already on). Release the PROGRAM key.

4. Press the INCREASE key to scroll up through the channels, from 1 to 8. Press the DECREASE button to scroll from 8 back to 1 to select the desired channel.

5. Once the desired channel is selected, press PROGRAM again, The unit will beep the same number of times as the channel selected. After a few moments the display will show “- -”.

6. With the main unit in this condition “- -”, press the pedal. While the pedal is pressed, the display will change to “-I-”.

The pedal is now set to the same channel and is matched with this laser. When the pedal is released, the display will return to “- -”. This indicates that the channel change was successful and the new channel is saved in the memory.

7. If any problems occur during this process, the display will show “E r”. If this occurs, turn the unit off, then on again. The original channel should be restored.

8. Once channel programming is complete, turn the unit back power fan switch off, then on again. The laser display should return to a laser power setting.



Step 1

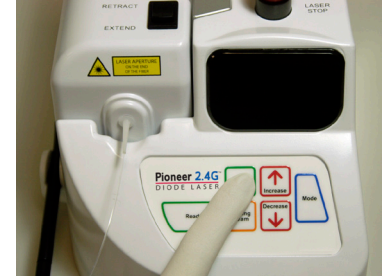

Step 2



Step 3

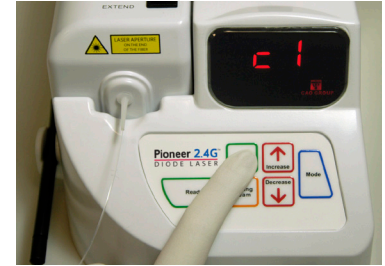

Step 3 (continued)



Step 4



Step 5



Step 6

3.2.8 Pioneer Pro Diode Laser Frequency:

The 2.4GHz frequency is popular for networks and other wireless devices that share similar technology. The nature of spread-spectrum modulation in the 2.4GHz frequency means that a multitude of devices can co-exist in the same 2.4GHz spectrum.

Since the 2.4GHz wireless receivers used in the Pioneer Pro have a much lower power output, it is unlikely that they would “interfere” with higher-power devices. If this were to occur, the higher-power devices would quickly switch to another channel to achieve uninterrupted operation.

The 2.4GHz wireless receiver uses an entirely different modulation scheme, and can not de-modulate (receive) data from Wi-Fi or Bluetooth devices. The converse is also true; their modulation methods are incompatible.

Pioneer Pro is electronically coded: each pedal and Pioneer Pro share a UNIQUE SERIAL NUMBER INTERLOCK protocol for reliable operation:

- The Pioneer Pro pedal communicates with only one Pioneer Pro diode laser, there is a 2-way electronic code which must be verified for easy transmission and acknowledgement. The pedal and laser unit are interlocked to only each other’s electronic codes.
- If data from one Pioneer Pro pedal is ever received, embedded verification measures ensure that it is always ignored and discarded.
- If data were ever received from another wireless device with a compatible modulation scheme (2.4GHz frequency), it would immediately be discarded in the same way.

In summary the wireless receivers in the Pioneer Pro have less than 2% of the output power of typical Bluetooth or Wi-Fi devices, and therefore can not mistakenly receive data from such devices.

SECTION 4– SAFETY CONSIDERATIONS

The safe use of the Pioneer Pro is the responsibility of the entire team including the doctor, staff and Laser Safety Officer. Protocols for the safe use of lasers have been developed by a combination of medical and dental professionals working in concert with educators at the university level, scientists and laser manufacturers. Sound judgment and the concern for patient safety should be the basis of all laser care. The following entities have influence over laser use.

4.0 Food and Drug Administration

Manufacturers of products subject to performance standards under the Federal Food, Drug and Cosmetic Act, Chapter V, Subchapter C – Electronic Product Radiation Control are required to demonstrate compliance with the regulations and furnish various reports to the Center for Devices and Radiological Health (CDRH). For medical laser manufacturers, additional review by the FDA of the safety and effectiveness of the device is required. Companies who intend to market a medical laser today must receive clearance from the FDA to permit the device into commercial distribution. There are two forms of pre-market clearance procedures. The premarket notification (510(k) procedure is principally used for those devices that are documented to be substantially equivalent to legally marketed Class I and Class II devices. For new devices not equivalent to legally marketed devices, a more complex PMA is required.

4.1 Wireless Technology

In order to promote efficient use of the radio spectrum in various global markets, the US FCC (Federal Communications Commission) and other international government agencies have developed technical standards for devices that are capable of emitting radio frequency energy when in use such as wireless data cards. These products need to receive certain identification numbers in accordance with the Commission Equipment Authorization rules prior to marketing in US markets. The FCC certification is similar to the CE certificate for the European markets. The Code of Federal Regulations, Title 47 (47 CFR), Part 15 covers the rules for the operation of unintentional, intentional or incidental radiators. Any electrical or electronic devices incorporating a digital circuitry and operating with an oscillator or clock speed of greater than 9kHz requires approval to this rule. There are various types of FCC Part 15 approvals, depending on the nature of the product and its intended use. In Canada, IC –RSS 210 (Radio Standards Specification) sets out the requirements for license exempt low-power international radiators. This standard is very closely harmonized in terms of permitted frequencies, types of operation, and other technical requirements to

the FCC requirements, but a separate certification application is required for Canada. In the European Community, compliance with several safety directives and testing to EN 300 328, EN 60950 and EN 301 489 is required for this type of device, The manufacturer is required to provide a Declaration of Conformity as evidence of its compliance with the various regulatory requirements.

4.2 Statutory Licensure

Check with your state board to confirm requirements for licensure and use of the Pioneer Pro.

4.3 OSHA and its Provisions

Worker safety is the responsibility of the employer and is regulated by OSHA (Occupational Safety and Health Administration), a division of the U.S. Department of Labor. OSHA has issued no specific standard for safe use of lasers but recognizes ANSI standard Z136.1 as a source for analyzing safety with respect to medical lasers. For more information see OSHA Technical Manual (TED 1-0.15A) Section III, Chapter 6, 1999. Pioneer Lasers, LLC recommends implementation of a Laser Safety Program for the safety of you patients and office staff in connection with the use of the Pioneer Pro.

4.4 Laser Safety Program

Pioneer Lasers, LLC recommends implementation of a Laser Safety Program appropriate for your office.

The plan should include the following:

- Delegation of authority and responsibility for supervision and control of the laser to a designated Laser Safety Officer
- Minimum Training requirements for users of lasers
- Security preventing unauthorized use of the laser
- Standard operating procedures to regulate the work environment in order to protect the patient and office staff from laser hazards.

The safe use of a laser is the responsibility of the Laser Safety Officer (LSO). It is their responsibility to train the staff, maintain records concerning training, the laser's performance, perform safety checks and prepare the laser for use on a daily basis. The LSO must keep records of any incidents that relate to the failure of the laser or any adverse effects related to laser therapy and report such incidents as prescribed by law. The LSO assures that a medical follow-up has been sought or has occurred following any adverse incident during treatment. The LSO is responsible for the training of all office personnel who are involved with the laser preparation and use. Daily checks of the facility and equipment are also the LSO's responsibility. The LSO should test fire the laser each day prior to beginning each treatment procedure. For more information on the contents of a Laser Safety Plan you can review ANSI Standard Z136.3 for Safe User of Laser in Health Care Facilities or TR IEC 60825-8 Guidelines for the Safe Use of Medical Laser Equipment.

4.5 Continuing Education

The Laser Safety Officer should insure that the operator and staff attend laser courses taught by qualified laser educators. Ongoing reviews of laser safety procedures should be a part of normal office routine.

4.6 In-Office Safety Issues

4.6.1 Lighting

Always use the Pioneer Pro in a well lit and ventilated area. Make certain that chemicals or gases capable of supporting or causing combustion are not present when using the laser. Use high volume vacuum to remove the laser "plume" and provide high filtration masks for all people present in the treatment area during lasing.

4.6.2 Safety Eyewear

While using the Pioneer Pro doctors, auxiliary staff, patients and anyone attending them in the operatory must wear the appropriate safety eyewear that has been designed for the use with the 810 nm wavelength. Never point the laser tip directly at the face, eyes or skin of anyone while emitting energy. The aiming beam is also capable of causing eye damage.

4.6.3 Test Firing the Laser

Always test-fire the Pioneer Pro prior to using it. To test fire the laser:

- Using a power of 1 Watt continuous wave or less, place the laser in the ready mode.
- Activate the laser for 1-2 seconds while aiming the fiber onto a 2x2 gauze sponge wetted with water. Do not use alcohol or any other combustible material to wet the 2x2 sponge as it may ignite.

4.6.4 Power Changes with Fiber Changes

Switching to a smaller diameter fiber will increase the density of the power at the fiber tip. As a result, you may need to adjust your power downward. Increasing the power may be required when switching to a larger diameter fiber. A smaller diameter fiber will require less power and conversely, a larger diameter will require more power.

4.6.5 Fiber Preparation

After cleaving and stripping the fiber, photo-initiation of the fiber tip will allow the operator to remove tissue more rapidly when contact procedures are indicated. Any debris on the tip will retain the heat and it should be removed. The tip will begin to blacken and deteriorate as it retains the heated debris and can break if not removed by cleaving. Clean the tip after using a 2X2 gauze sponge moistened with water. Do not use combustible liquids to moisten the 2X2.

4.6.6 Danger - Laser in Use Signage

Each area where a Pioneer Pro is used should have a "Laser In Use" sign placed at the entrance when a procedure is in progress, this will help eliminate eye damage caused by inadvertent exposure to laser energy.

4.6.7 Sharps Disposal and Sponge Removal

Remove cleaved fiber remnants and place them into a sharps container for disposal, All sponges used for cleanup of lasers and fibers should be disposed of in a biohazard bag for contaminated soft products.

4.6.8 Plume Evacuation

Use high volume evacuation suction during procedures to remove laser smoke of "plume" debris. Use masks suitable for viral filtration, Caution – Laser plume may contain viable tissue particulates.

4.6.9 Key Switch and Mode Selection

When the key switch is in the ON position (turn to the right), the laser has been enabled and can be activated while in the READY status. When not in use, insure the key has been turned off or that the laser is placed in the STANDBY status.

4.6.10 Safety Education

Provide comprehensive safety procedure training for all office personnel and include the staff in all outside laser courses when possible. Be certain that all members of the team understand how the laser works.

4.6.11 Laser Security

To prevent the unauthorized use of the laser while not in use, the key should be removed from the unit and maintained by the Laser Safety Officer.

4.6.12 Emergency Shutdown Options

Any of these mechanisms can be used to shut down the emission of the laser energy in a real or perceived emergency.

1. Depress the emergency shutdown button
2. Foot Pedal - remove your foot to stop lasing
3. Key – Turn off the key
4. Switch the Power/Fan to the off position (O)
5. Power Cord – Unplug from the wall outlet

4.6.13 Hard Tissue Procedures

The Pioneer Pro is not an appropriate laser for hard tissue procedures. The diode laser is attracted to melanin, hemoglobin and to some extent water and oxygenated hemoglobin.

4.7 American National Standards Institute (ANSI) – Safety Standards

ANSI is a non-governmental, non-profit agency that has established guidelines and safety standards for the use of lasers and other electro-optics. ANSI establishes guidelines for safety eyewear and classifies all lasers based on their potential for damage to eyes or tissue. You will also find information concerning lasers at Lasermet.com

SECTION 5 – OPERATING THE LASER

The Pioneer Pro will deliver energy in either a continuous wave (CW) mode or in a pulsed mode which are called temporal emission modes (time related modes). Selecting the appropriate mode is a factor in controlling target tissue temperatures and the efficiency of energy delivered. The pulse duration (0.05 seconds) and the number of pulses per second (10) have been fixed by the manufacturer using a 50% duty cycle and you will therefore need only to change the power and mode.

5.0 Standby and Ready Status

Once you have turned on the power /fan switch on the back of the laser and the key switch on the front, you will see the laser's LED screen light up. The status of the laser will be in "Standby" which is a non-active status. The laser will not emit energy while in Standby; even if you depress the foot pedal. Press the READY button to place the unit in the ready status. When this button is pressed, whatever settings are displayed on the unit will be saved into the unit's memory for the program setting shown. The settings saved into the three programmable modes will be retained even if the laser is turned off. Any adjustments to the manual settings after the laser is in the ready status will now be saved to memory. The laser will now be ready to emit energy as you depress the foot pedal.

5.1 Continuous Wave (CW) Mode (see Figure 3.2 and 3.2a)

The Continuous Wave (CW) mode, will deliver the amount of energy in joules in one second that you have set the laser for (i.e., set the laser for 2 Watts CW and while in the ready mode, the laser will deliver 2 joules of energy per second as long as you have the foot pedal depressed.) The Continuous Wave mode is generally the fastest way to ablate tissues; however heat may build up and cause collateral damage to the target and adjacent tissues. You may use water or air to cool areas that experience prolonged exposure to the laser's beam. Avoid using compressed air when you have an opening in soft tissue adjacent to, or within the surgery site. An air embolism may occur as a result of air captured within the tissue during the cooling process.

5.2 Pulsed Energy Mode

Pulsing the laser will allow some cooling of the tissue in between emissions of energy. The “duty cycle” is the percentage of the time in each second that the laser is emitting energy. The pulses per second, the duty cycle and the energy intensity per pulse will determine your average power. In the pulse mode the Pioneer Pro is programmed to deliver 10.0 pulse per second with each pulse lasting for 0.05 seconds. The duty cycle is set for 50% so you will have 1 energy pulse with 1 period of rest with no energy between each pulse. If the laser is producing energy at 10 times per second for 0.05 seconds per pulse, you will be producing energy for a total of 0.5 seconds for every 1 second the laser is active. The result will be an average power per second that will be 50% of what you have set the laser for. Therefore, when using pulsed energy, you will have to adjust your power upward in order to achieve the same rate of work as the same power set in CW. 2 Watts of Pulsed energy will be the same average power output as 1 Watt CW.

5.3 Tissue Responses to Laser Energy

Maximum results will be achieved by regulating the power and the speed that the operator moves the fiber tip. Tissue charring is an undesirable after effect of too much power or the tip moving too slowly. Always use the least amount of power necessary to complete your procedure. The ideal tissue response will show little or no discoloration after lasing and there will be less residual damage and faster healing. Avoid penetrating or damaging bone. Check to make sure you have a good cleave of the fiber so that no shard is present on the tip. A shard may act as a miniature scalpel and damage small blood vessels, thus preventing homeostasis and coagulation.



Figure 5.1 Fiber with a shard (a bad cleave)

5.4 Fiber and Handpiece Care

Do not continue to use the fiber tip once you have observed that the tip has a blackened appearance that is greater in length than 2-4 mm from the previous cleave spot. The protein debris of soft tissue accumulates on the tip during surgery and retains extreme heat that can cause rapid tip deterioration and subsequent breakage. This is especially important when using the laser in contact mode procedures. Clean the tip often using a sponge or cloth moistened with water. Do not use alcohol or other combustible liquids and do not use the sponge while the tip is hot. Always use a cold disinfectant solution to wipe off the fiber jacket before retracting the fiber. The fiber cartridge is a removable assembly with a plug-in capability that provides power for the internal retraction device. This cartridge is disposable after all fiber has been used. This cartridge is not autoclavable. The handpiece should be autoclaved after each patient and a new disposable tip applied. Dispose of the cleaved tip in a “Sharps” waste receptacle. Be advised about the potential hazards when inserting, steeply bending, or improperly securing the fiber optics to the chassis. Radiation exposure may occur in these instances which could be harmful to yourself, you staff and your patient. Special care should be taken not to break or snap the fiber. As the aiming beam passes down the same delivery system as the Working Beam, it provides a good method of checking for integrity of the delivery system. If the aiming beam spot is not present at the distal end of the delivery system, its intensity is reduced or it looks diffused, this is a possible indication of a damaged or not properly working delivery system.

5.5 WARNING

DO NOT PLACE THIS FIBER AND FIBER CARTRIDGE IN THE AUTOCLAVE TO STERILIZE THE SYSTEM. USE COLD DISINFECTING SOLUTIONS TO WIPE DOWN THE FIBER AND THE EXTERIOR OF THE LASER FIBER CARTRIDGE.

5.6 Systems Procedures

5.6.1 Treatment Area Requirements

The laser should be placed in an area with good ventilation and lighting. The electrical service required is a 110 Volt AC outlet-60Hz. The area where the laser is placed should be free of standing water. Combustible gases should be turned off and all flammable materials or chemicals stored in the area should be removed.

5.6.2 Foot Pedal

It is recommended to use a 9 volt Lithium battery to power the cordless foot pedal. This type of battery has been tested to last for over 100 hours of foot pedal operation. When the battery voltage begins to drop, the foot pedal will begin to beep, signaling that you have approximately 2 hours of operating time left before the battery life is completed. Note: A 9 volt Alkaline battery may be used; however the life expectancy of an Alkaline battery is less than 35 hours of operating time.

5.6.3 Fiber Cartridge

Before using the laser, check the fiber cartridge to see that it is firmly seated, Depress the extend/retract rocker switch on the cartridge to see that it is functioning properly. After checking the fiber cartridge power, extend some fiber from the cartridge.

5.6.4 Fiber Preparation (see Figure 3.7 and 3.7a on page 12)

You will want to have approximately 3 feet (1 meter) of fiber available to strip the fiber, cleave the fiber, initiate the fiber and disinfect the fiber. When the fiber is prepared the handpiece and tip should be attached. Once prepared place the handpiece into the holder on the side of the laser. The rocker switch for fiber cartridge operation should not be depressed during laser operation.

5.6.5 Emergency Shutdown Button

Check the Emergency Shutdown Button to see that it has not been depressed. If it has, release it by depressing it slightly as you turn it ¼ turn to the right.

5.6.6 Key Switch

Turn the Key Switch on the front of the laser to the “on” position by turning it approximately ¼ turn to the right (clockwise). The control panel should light up and show the laser is in the Standby Mode.

5.6.7 Setting Parameters (see Figure 3.2a on page 11)

Review your power and mode requirements and then depress the mode button to select either Continuous (CW) or pulsed-mode. The mode you have selected will be displayed just below the LED screen and will be designated by a small light in the corner of either of the pulse or CW panel Display.

5.6.8 Select Your Power

Press the up or down arrow until you have reached the desired Wattage. Beginning with a low of 0.1 Watts, the power increases in increments of 100 mW up to a maximum of 5.0 Watts (CW). By holding the up or down arrow, you can have an un-interrupted increase until you reach your desired power.

5.6.9 Selecting Programs

Press this key to select either manual (M) or one of three user defined programs (P1, P2, P3). Each program will save all of the parameters – working bean, aiming beam and mode of operation. The settings can be changed as desired for any of the program modes. To set the user defined program modes, choose either P1, P2, or P3, set your preferred settings and push the ready button. Upon activating the ready button, the new settings will be saved in the unit's memory.

5.6.10 Aiming Beam

The aiming beam can be turned on and off by pressing the aiming beam button on the laser control panel. Press this button to progressively increase the aiming beam intensity from O (off) to full intensity. Press the key once more to cycle back to O. Each bar represents approximately 20% of the aiming beam output.

Note: Adjusting the intensity of the aiming beam has no effect on the output power of the primary laser.

5.6.11 Examine the Fiber Tip

Insure that you have not created a fiber tip shard during the cleaving process, the shard can act like a miniature scalpel and cause damage while diffusing the light beam and lowering the laser's power.

5.6.12 Depress the Ready Button

When you depress the ready button, the aiming beam should light after a 2 second delay. Select either CW or pulse mode.

5.6.13 Test Fire the Laser

Away from tissue, test fire the laser on a 2X2 gauze sponge that has been wetted with water.

5.6.14 Depress the Foot Pedal

Make short quick strokes at the lowest power to remove target tissue while lightly contacting it.

5.6.15 Remove Your Foot

Remove your foot from the foot pedal and use a clean 2X2 wetted gauze to remove debris from the fiber tip.

5.6.16 Place the Laser in Standby Mode

Until you are ready to start another procedure, keep the laser in standby mode.

5.6.17 Cleave used Fiber Tip

Discard all cleaving and used fiber tips in a bio-waste disposal.

5.7 Clinical Procedures

The following table identifies the preferred laser settings for performing the procedures this device is cleared for. The clinician should exercise professional judgement and adjust the settings as appropriate according to the circumstances of each individual patient. Factors such as pigmentation, capillary perfusion, tissue thickness and health, and others will impact the way the tissue responds to the laser energy.

Procedure	Fiber Preparation	Technique	Mode	Power (W)
Contouring	Initiated	Contact	Continuous	1.2
Crown Lengthening	Initiated	Contact	Continuous	1.2
Curettage	Initiated	Contact	Pulse	1.4
Distal Wedge	Initiated	Contact	Continuous	1.5
Emergence Profile	Initiated	Contact	Continuous	0.8
Frenectomy	Initiated	Contact	Continuous	1.0
Gingivectomy	Initiated	Contact	Continuous	1.0
Gingivitis	Un-initiated	Contact	Pulse	0.8
Hemostasis	Initiated	Non-contact	Continuous	0.8
Implant Exposure	Initiated	Contact	Continuous	1.0
Lesion	Un-initiated	Contact	Continuous	0.8

Procedure	Fiber Preparation	Technique	Mode	Power (W)
Operculectomy	Initiated	Contact	Continuous	1.5
Ovate Pontic	Initiated	Contact	Continuous	1.0
Periimplantitis	Initiated	Contact	Pulse	1.5
Smile Design	Initiated	Contact	Pulse	1.8
Troughing	Initiated	Contact	Continuous	0.8

Table 5.1. Recommended settings for clinical procedures.

5.8 Self Diagnostic and Monitoring

When the Pioneer Pro's microprocessor detects an issue with performance it will immediately notify you by way of an audible beep. There are two different ways in which the Pioneer Pro will alert you to any issues:

1. Continuous audible beep when foot pedal is engaged. If you are operating the Pioneer Pro with the foot pedal engaged and the Pioneer Pro emits a constant audible beep and stops the beep when you release the foot pedal, the microprocessor has determined that the laser power output has fallen below the set level. In this event the Pioneer Pro should be turned off and allowed to sit for 5 minutes then turned on again. If the Pioneer Pro then performs without beeping, the microprocessor has been able to make operational adjustments to the laser and the unit will perform its functions. If, however, upon restart the unit continues to beep when the foot pedal is engaged, the microprocessor was unable to adjust the unit enough and the unit will need to be sent in for adjustment. (Section 6)
2. Continuous audible beep when the unit is turned on. If you are operating the Pioneer Pro and it emits a constant audible beep whether or not the foot pedal is engaged, the microprocessor has determined that the laser has either low power or a general fault has occurred. In this event the Pioneer Pro should be turned off and allowed to sit for 5 minutes and turned on again. If the Pioneer Pro then performs without beeping, the microprocessor has been able to make operational adjustments to the laser and the unit will perform its functions. If, however, upon restart the unit continues to beep, the microprocessor was unable to adjust the unit enough and the unit will need to be sent in for adjustment. (Section 6)

SECTION 6 – SYSTEM COMPONENTS PREPARATIONS, CARE AND MAINTENANCE

The fiber optic element of a laser is responsible for carrying the light from the diode array to the tissue being treated. Laser fibers are usually made of quartz, sapphire, silica or a combination of those elements. Quartz/silica is the most popular product used in diode lasers. Be advised about the potential hazards when inserting, steeply bending or improperly securing the fiber optics to the chassis. Radiation exposure may occur in these instances which could be harmful to yourself, you staff and your patient. Special care should be taken not to break or snap the fiber. As the Aiming Beam passes down the same delivery system as the Working Beam, it provides a good method of checking for integrity of the delivery system. If the aiming beam spot is not present at the distal end of the delivery system, its intensity is reduced or it looks diffused, this is a possible indication of a damaged or not properly working delivery system.

6.0 Disposable Fiber Cartridge

The fiber cartridge is a removable assembly with a plug-in capability that provides power for the internal retraction device. This cartridge is disposable after all fiber has been used. This cartridge is not autoclavable.

6.0.1 Replacing the Fiber Cartridge

A black mark on the fiber indicates 6' of fiber remaining on the cartridge. At this point, a new fiber cartridge should be ordered. When the cartridge is empty, it should be released from the laser aperture and gently removed. Slowly lift the cartridge up using the dove tail as a guide. The fiber cartridge can be thrown away.

Note: Retain the end cap; do not discard the end cap. Review the installation procedure in Section 3.1.8

6.1 Fiber Preparation

The fiber cartridge contains approximately 20' (6 meters+) and is wound onto a spool. The fiber itself has three components

- Jacket
- Cladding
- 400 micron quartz/silica fiber

6.1.1 Jacket

This is the protective cover for the fiber system and usually is made of a synthetic material that is clear or white in color, there are no standardized color systems to denote the diameter of the fiber or its use.

6.1.2 Cladding

This is the material on the outside of the quartz/silica fiber that is used to block the lateral escape of the laser energy as it traverses the fiber. During stripping you may "nick" the cladding and you will likely see the red aiming beam light as it escapes the site of the damage. This is not a danger if all people in the area have the appropriate safety eyewear.

6.1.3 Quartz/Silica Fiber

The fiber is fairly flexible but can be broken if bent into a small circle or bent as an angle of 90°. The cladding will burn as protein from the tissue accumulates on the fiber and will deteriorate the tip. It can fracture if not cleaved once the blackened area has reached 3-4 mm. Stop lasing and wipe off the tip regularly as you work to avoid accumulation of protein debris. Use water on a 2X2 gauze sponge to clean the tip. Do not use flammable materials like alcohol products when cleaning a hot tip. Dispose of all small fiber remnants after you have cleaved the fiber. They should be kept in a small box with a lid until they can be properly disposed of in the "sharps" container.

6.1.4 Stripping the Fiber

The fiber's jacket is removed using the fiber stripping tool. Once a fiber tip is initiated and begins retaining debris from the tissues during lasing, you will get a deterioration of the fiber tip. When you have a blackened tip that extends 3-4mm up the fiber shaft, it is time to cleave the fiber and strip the jacket to prepare for the next procedure. Begin by selecting enough jacket so that when it is removed, you will have approximately 3/8" of bare fiber exposed. Place the fiber in the stripper and grasp that portion of the fiber that will have the jacket removed between your thumb nail and index finger (SEE FIGURE 6.0). Grasp the fiber with the stripper by applying pressure to the handles. With a slow steady force, remove the jacket by pulling the fiber away from the stripper.

(SEE FIGURE 6.1 and 6.1a)

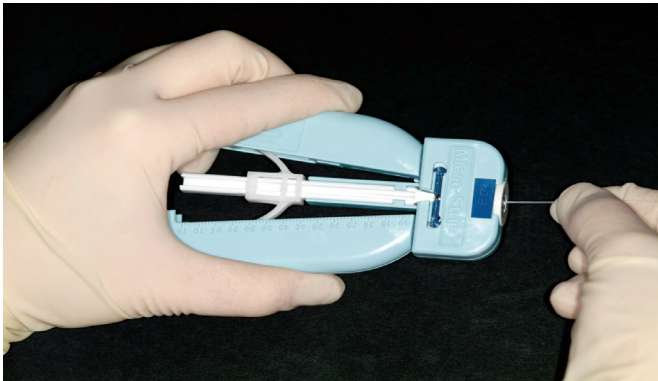

Figure 6.0 Adjustable Fiber Stripper Tool

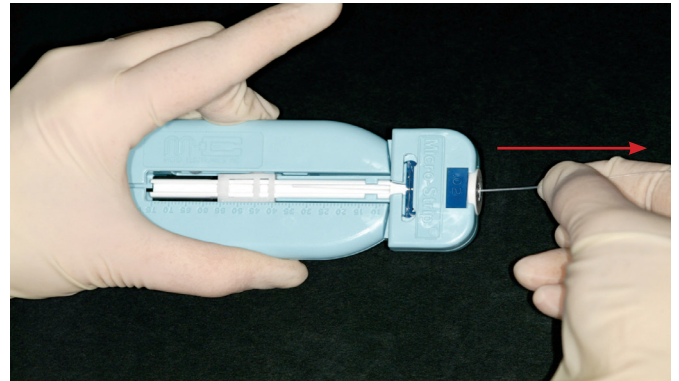
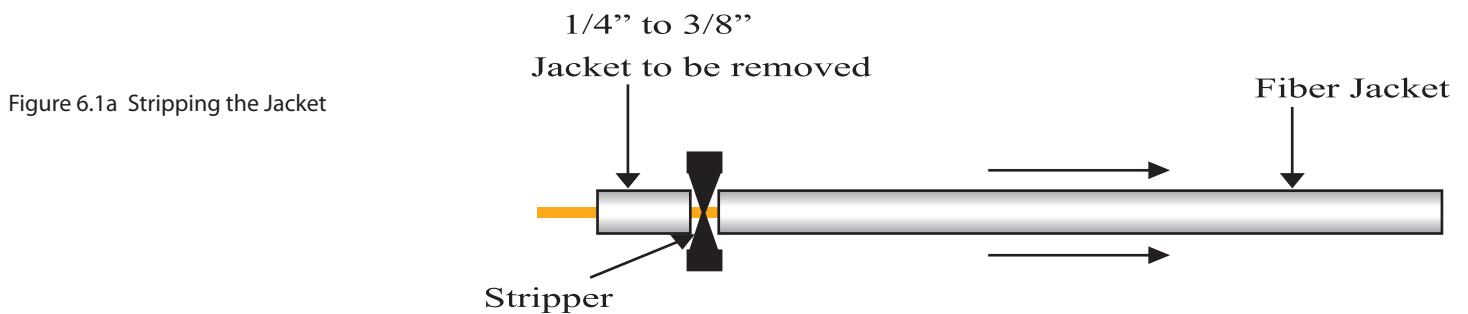

Figure 6.1 Removing Jacket with Stripper Tool



6.1.5 Cleaving the Fiber:

As the tip deteriorates, it is more likely to fracture and could fall into the area you are lasing. To avoid this, it is prudent to periodically "cleave" the discolored tip. The cleave is made after stripping off the jacket to expose approximately 1-4" – 3/8" of bare fiber. The cleave should be made at a point approximately 1/2" (8 – 10mm) from the site of the previous cleave so that there is no visible discoloration of the tip. The operator should place their index finger at the spot of the proposed cleave so as to stabilize the fiber. Using the pen style cleaver, draw the cleave blade across the top of the fiber with enough pressure to "score" the fiber. (See Figure 6.2). With the thumb and index finger of each hand holding the fiber at a spot approximately 1/2" on either side of the cleave mark, break the fiber against the cleave (See FIGURE 6.2a). After you have cleaved the fiber, point it perpendicular to a piece of white paper and place the laser in READY mode. Hold the tip approximately 1/2" from the paper and you should see a near perfect circle of red light, If you have a large comet effect radiating from the circle, you have not obtained a good cleave. If the circle has just a small comet effect, it should work appropriately. (See FIGURE 6.3 and 6.4)

WARNING: Always dispose of the fiber tip remnants in the "Sharps" container immediately after cleaving the fiber.

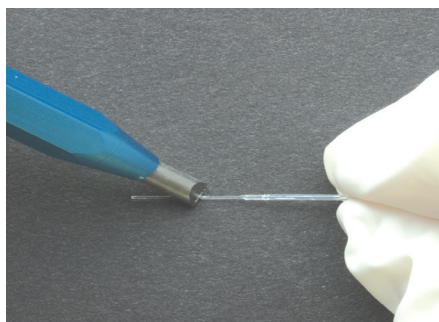

Figure 6.2 Scoring & Cleaving

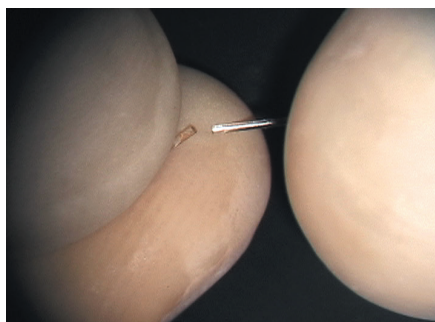

Figure 6.2a Break the fiber against the cleave



Figure 6.3
Good Cleave



Figure 6.4
Bad Cleave

6.1.6 Initiating the Fiber

The tip of the fiber should be cleaved to provide a flat surface that can be prepared to retain heat by introducing it to a dark material like ink, blood or water color paints. The easiest way to prepare the tip is to lightly move the flat surface of the tip across a piece of articulating paper, the tip will retain the ink and ink will make the tip glow. Prolonged heating will accelerate the deterioration of the tip. (See FIGURE 6.5)

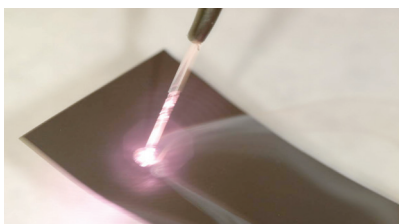

Figure 6.5

Move the tip left or right while lightly touching the paper

WARNING: Using too much power can start a fire on the articulating paper

6.1.7 Fiber Disinfection

The fiber and spool remain in the fiber cartridge and are not autoclavable while in the cartridge. Once stripped, cleaved and initiated, the tip will reach temperatures of several hundred degrees centigrade. Wipe the jacket down using Birex™, Cidex™ or a comparable product that can disinfect the jacket. Dry the jacket using a clean 2X2 sponge prior to retracting the fiber into the fiber cartridge. (See section 6.0)

6.2 Laser Maintenance

6.2.1 Laser Chassis Disinfection

The exterior of the laser should be cleaned using a liquid disinfectant similar to Birex™, Cidex™. Do not spray the disinfectant directly on the chassis. Apply with a gauze sponge or wipe. Do not use abrasive materials to clean the system. Place a barrier material similar to cellophane over the control panel and LED screen prior to treating the next patient.

6.2.2 Calibration

The Pioneer Pro is calibrated at the factory, and requires no user adjustment or periodic calibration once the unit is in use. The laser contains internal calibration programming that continuously monitors and adjusts the working beam power relative to the factory established reference points, ensuring that the laser continuously provides the power output indicated on the display to an accuracy of $\pm 20\%$, regardless of how long the unit has been in use.

The Pioneer Pro uses solid-state circuitry to continuously monitor the power output, and adjusts the power supplied to the laser module to keep the output consistent with the user defined setting. If output levels are more than $\pm 20\%$ of the set value, the unit is designed to shut down power to the laser, and an audible alarm will sound. If this happens, the unit should be turned off and allowed to sit for 5 minutes and turned on again. If the laser then performs without beeping, the microprocessor has been able to make operational adjustments and the unit will perform its functions. If, upon restart, the unit continues to beep, the unit will need to be sent in for adjustment by Pioneer Lasers, LLC.

It is suggested that your practice establish an internal calibration verification program for your laser. Verification is recommended a minimum of once per year based on average usage. Verification may be performed by the manufacturer by returning the unit. As an alternative, you may purchase a calibrated hand held power meter approved for use with 810nm devices to check power output. The laser should be set at 1, 3, and 5 Watts with output checked at each level. The output display should be within 20% of the meter reading. If not, re-cleave the fiber and re-check. If the output display is still outside the 20% tolerance, return the unit to the manufacturer for recalibration. There are no methods available for the user to adjust the calibration of the unit and the unit chassis must not be removed by the user for any reason.

6.3 Handpiece Preparation

6.3.1 Autoclavable

The handpiece is an autoclavable material that should be cleaned with warm soapy water, rinsed, bagged and autoclaved after each patient.

6.3.2 Handpiece Components

The handpiece has three (3) components:

1. Body
2. Disposable Tip
3. Fiber Locking Cap

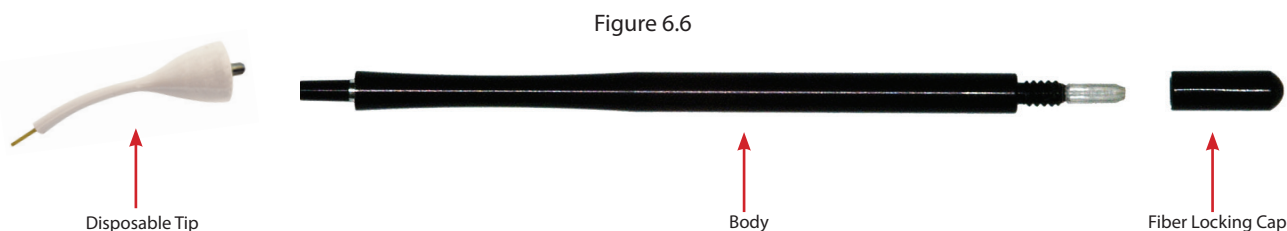

6.3.3 Rocker Switch

Using the rocker switch on the top of the fiber cartridge, press the switch to the extend position (toward the front of the laser). Extend 3-4 feet of fiber and feed it through the fiber locking collar after you have loosened the collar. The fiber should extend about 1 foot beyond the distal end of the handpiece so that you can strip the fiber and place the disposable tip.

6.3.4 Disposable Tips

The disposable tips can be shaped to provide the clinician with any degree of access required.

6.3.5 Prepare Fiber

Using your stripper, remove approximately 1/4 - 3/8 inch of jacket from the distal end of the fiber. Cleave the fiber and examine the results by turning the laser to the READY status. The aiming beam should create a near perfect circle when directed onto a white surface from about 1/4 - 3/8 inch above the paper. (See FIGURES 6.3 and 6.4) Once cleaved, the fiber tip should be disinfected. (Section 6.1.7)

6.3.6 Mounting the Tip

After selecting your tip, straighten it using your thumb and index finger. Begin at the proximal end of the tip and feed the stripped end of the fiber through the straightened tip until only bare fiber is extending beyond the disposable tip. Gently slide the disposable tip onto the distal end of the handpiece and pull the fiber from the proximal end until the disposable tip is almost seated on the handpiece body. Seat the disposable tip securely on the handpiece body and tighten the locking collar. You may now shape the disposable tip to the desired form. Press the rocker switch to make sure the fiber moves freely. You should now initiate the fiber tip if your procedure calls for it.

SECTION 7 – LABELS, SIGNS, WARNINGS AND MANUFACTURER’S INFORMATION

7.1 Federal Compliance

The Pioneer Pro has been designed to comply with the latest safety standards applicable to medical lasers in the US and Canada including IEC 60825, IEC 60601-2-22, IEC 60601-1 and the Food and Drug Administration’s Laser Performance Standard (21 CFR 1040.10 and 1040.11) The laser has also been certified and tested according to the telecommunications regulations for the US (FCC Part 15), Canada (IC RSS 210) and the European Community (EN 300 328, and EN 301 489). Various labels are included on the laser and the wireless footswitch as evidence of conformity to these requirements. The labels on the unit are required under these standards for safety purposes and should not be removed. Please review all labels prior to using the laser. (SEE FIGURES 7.0.1, 7.0.2, 7.0.3 and 7.0.4)

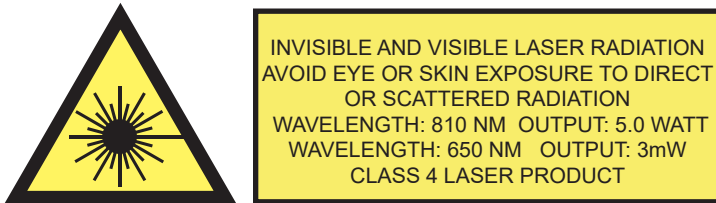

Figure 7.0.1 Label required under FDA laser notice 50

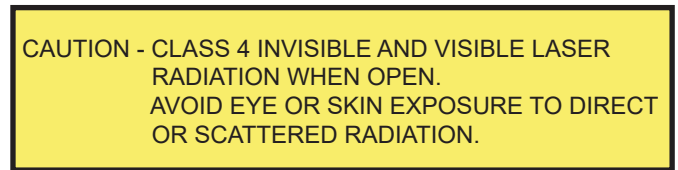

Figure 7.0.2 Label required under FDA laser notice 50

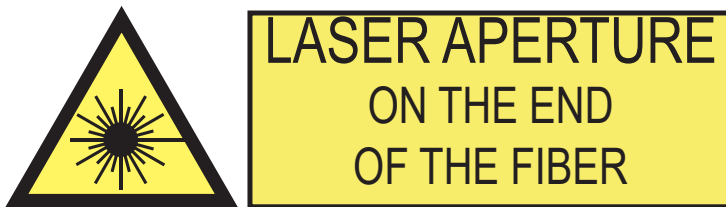

Figure 7.0.3 Laser Aperture Label

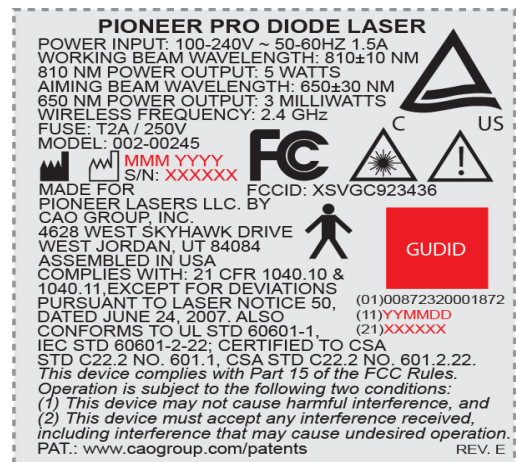

Figure 7.0.3 Rating Label with serial number



Figure 7.1

7.2 Danger Laser in Use

Each treatment area should have a “laser in use” warning sign posted at the entrance to the treatment area. This signage serves to warn people to not enter the treatment area without proper safety eyewear and protective clothing when the laser is in use. (See Figure 7.1)

7.3 Class 4 Laser Product – (treatment laser) 810 nm 5 W

7.4 Aiming Beam Laser – 630 – 660 nm 2 mW

7.5 CAUTION:

Changes or modifications not expressly approved by Pioneer Lasers, LLC could void the user’s authority to operate the equipment.

7.6 CAUTION:

Laser Radiation – Avoid exposure to the eyes or skin from direct or scattered radiation.

7.7 CAUTION:

This product contains no user serviceable components within the chassis. Visible and invisible radiation may be present when the cover is removed.

7.8 CAUTION:

US Federal law restricts the device to sale by or on the order of a licensed professional.

7.9 CAUTION:

Eyewear that protects your eyes from wavelengths other than 810 nm do not provide proper protection for use with this laser , Damage to the retina or corneal may be irreparable if exposed to direct, reflected or scattered radiation.

7.10 CAUTION:

Use of controls or adjustments, or performance of procedures other than those specified herein may result in hazardous radiation exposure.

7.11 Nominal Ocular Hazard Distance (NOHD)

The NOHD is the distance beyond which the exposure during normal operation is not to exceed the appropriate Maximum Permissible Exposure (MPE). The NOHD for persons wearing safety glasses is shown in Table 1 below. The Nominal Hazard Zone (NHZ) is the area where the laser source within which exposure levels exceeds the MPE (which is the highest level of laser radiation to which a person may be exposed without hazardous effects or adverse biological changes in the eyes or skin). The outer limit of the MHZ is the NOHD. Eye Protection within the NHZ is mandatory.

Source of Radiation	MPE (mWcm ²)	Divergence angle (degrees)	NOHD (inches)	
			No Eyewear inches/cm	With Eyewear (OD=4) inches c/m
Fiber optic devices	1.66	9	107/272	1.07/2.72
Reflection from Tissue	1.66	N/A	0.030/0.076	0.0003/0.00076

Assumptions: Maximum Laser Power = 5 Watts Direct viewing angle =0, reflectance viewing angle =20°, reflectance coefficient of tissue = 0.001

Table 1 - Nominal Ocular Hazard Distance (NOHD) for various viewing conditions while wearing eye protection.

NOTE: This equipment has been tested and found to comply with the limits for a Class A digital device, pursuant to Part 15 of the FCC Rules. These limits are designed to provide reasonable protection against harmful interference when the equipment is operated in commercial environment. This equipment generates, uses, and can radiate radio frequency energy and, if not installed and used in accordance with the instruction manual, may cause harmful interference to radio communications. (Operation of this equipment in a residential area is likely to cause harmful interference in which case the user will be required to correct the interference at his own expense).

7.12 Warning and Safety Notices:

WARNING: To avoid the risk of electrical shock, this equipment must only be connected to a supply main with protective earth.

7.13 Environmental protection disposal of the equipment:

This is a medical laser device; dispose of this device and all accessory items in accordance with state, local and federal rules on the disposal of laser equipment.

SECTION 8 – SERVICING

8.1 Limited Warranty:

Pioneer Lasers hereby warrants against defects in materials and workmanship of the following portions/aspects of the Pioneer Pro diode laser along with its components and accessories (collectively referred to herein as Product):

- 24 months for the laser unit and foot pedal;
- 6 months for the fiber cartridge;

This warranty shall be in effect as of the date of purchase only by the original end user of the respective items. This warranty shall include the cost of labor associated with addressing the defect in materials or workmanship.

This warranty does not include, cover, or apply to the following:

- All other accessories and single-use, consumable, or disposable accessories or aspects of the Product;
- The cost of freight/postage associated with movement of the Product for the purposes of fulfilling this warranty;
- Damage to the Product resulting from accident, misuse, alteration, or failure to follow the instructions contained within this document;
- Courtesy review, examination, or calibration of the Product not related to a declared defect;
- Ordinary wear to the Product consistent with natural aging, use and handling, and/or as a result of following the cleaning, care and maintenance instructions of this document;
- Damage incurred in transit due to failure to package the Product in its original factory packaging;

This warranty does not cover, and Pioneer Lasers is not liable for, any loss of revenue incurred due to the Product requiring replacement, repair, or servicing. The owner/user of the Product is required to read this document in full prior to use of the Product, and the owner/user accepts all liabilities and risks associated with use of the Product. This warranty is valid only to the original end-use purchase and is not transferrable.

If upon examination of the Product, within the timeframes specified above, the Product is found to be defective in materials or workmanship, Pioneer Lasers shall repair or replace at its discretion such defects in materials or workmanship and shall not charge the owner/user only for materials associated with such repair or replacement. Pioneer Lasers reserves the right to make changes in design or to modify the Product subsequent to its original manufacture. If upon examination the Product is found to be free of the claimed defects in materials or workmanship to which application under this warranty is lodged, the user/owner shall be charged for the labor necessary to perform the examination of the Product. This warranty is voided if anyone other than a Pioneer Lasers authorized service center performs service, calibration, or repair of the Product not described in this document.

In the event that the owner/user informs Pioneer Lasers of Product defects and the owner/user of the Product does not cooperate with Pioneer Lasers to accommodate repair, servicing, or replacement of the defects, this warranty shall be voided relative to such original defects and to all subsequent defects resulting from the continued presence of the original defects or continued use of the product with the original or new defects. Additionally, Pioneer Lasers is not liable for any death, injury, or property damage due to continued use of the Product with a defect present that is knowingly unaddressed by the owner/user. This warranty holds supremacy to any other agreement, guarantee or warranty, oral or written, expressed or implied, except such written agreements issued directly by the Pioneer Lasers and mutually entered into between the Pioneer Lasers and the ultimate owner/user of the Product.

8.1.2. Repairs & Returns

If you are not satisfied with the Pioneer Pro, Pioneer Lasers extends the opportunity to obtain a full refund of the purchase price of the Product (not including fees, shipping, etc.) when ALL of the following conditions are met:

- The Product is returned to and arrives at Pioneer Lasers within 30 calendar days from the date of purchase;
- The Product is returned with all accessories and packaging originally shipped with the Product (minus consumables that may have been used); and
- All aspects of the Product, including accessories, documentation, and packaging are free from any damage;

If slight damages or a significant reduction in consumable items are identified, a refund may be provided for the purchase price discounted by 15% to cover reconditioning, replenishment of consumables, replacement of damaged items and restocking. If extensive damage is identified, the refund may be further discounted to offset the cost of damages.

Notwithstanding, no refund is offered if more than 30 days has passed since the date of purchase.

Send repair and returns to Pioneer Lasers, LLC. Should the laser fail to operate correctly and your local dealer representative is unable to assist you, please call Pioneer Lasers, LLC Customer Service (1-877-236-4402) to obtain a Return Material Authorization (RMA) number for shipping purposes. Please insure that the RMA number is clearly marked on the box used to return the laser. Please clearly state the reasons for return.

Send returns to:

In the United States
Pioneer Lasers, LLC
Attn: Service Department
4628 West Skyhawk Drive
West Jordan, UT 84084

CAUTION! Use of controls or adjustments or performance of procedures other than those specified herein may result in hazardous radiation exposure.

CAUTION! Do not attempt to remove the cover from the laser chassis for the purpose of repairing the laser. Serious Injury from an electrical shock or laser radiation could occur. Removing the cover on the laser chassis will void the warranty.

REGULATORY INFORMATION:

Food and Drug Administration

The Pioneer Pro is FDA 510(k) approved and follows all appropriate regulations.

The Pioneer Pro is indicated for the procedures of removal of lesions, excision, incision, vaporization, ablation, hemostasis, and photocoagulation on soft tissue in the fields of dentistry and oral surgery.

Medical Laser Standards

The Pioneer Pro has been designed to comply with the latest safety standards applicable to medical lasers in the US and Canada including IEC 60825, IEC 60601-2-22, IEC 60601-1 and the Food and Drug Administration's Laser Performance Standard (21 CFR 1040.10 and 1040.11), US (FCC Part 15), Canada (IC RSS 210) and the European Community (EN 300 328, and EN 301 489). Various labels are included on the laser and the wireless foot switch as evidence of conformity to these requirements. The labels on the units are required under these standards for safety purposes and should not be removed. Please review all labels prior to using the laser.

Wireless Technology

This device complies with Part 15 of the FCC Rules. Operation is subject to the following two conditions: (1) this device may not cause harmful interference, and (2) this device must accept any interference received, including interference that may cause undesirable operation.

The wireless footswitch complies with US FCC, Title 47 (47 CFR); Canada, IC-RSS 210 (Radio Standards Specification); and European Community, EN 300 328, EN 60950 and EN 301 489.

1. This device may not cause harmful interference, and
2. This device must accept any interference received, including interference that may cause undesired operation.

NOTE: This equipment has been tested and found to comply with the limits for a Class A digital device, pursuant to Part 15 of the FCC Rules. This equipment generates, uses, and can radiate radio frequency energy and, if not installed and used in accordance with the instruction manual, may cause harmful interference to radio communications.

(Operation of this equipment in a residential area is likely to cause harmful interference in which case the user will be required to correct the interference at his own expense).

OSHA and its Provisions

Worker safety is the responsibility of the employer and is regulated by OSHA (Occupational Safety and Health Administration), a division of the U.S. Department of Labor. OSHA has issued no specific standard for safe use of lasers but recognizes ANSI standard Z136.1 as a source for analyzing safety with respect to medical lasers. For more information see OSHA Technical Manual (TED 1-0.15A) Section III, Chapter 6, 1999. LLC recommends implementation of a Laser Safety Program for the safety of your patients and office staff in connection with the use of the Pioneer Pro Diode Laser.

American National Standards Institute

(ANSI) - Safety Standards ANSI is a non-governmental, non-profit agency that has established guidelines and safety standards for the use of lasers and other electro-optics. The provisions of ANSI Z 136.3 outline standards for lasers used in medicine and the assessment of laser risks. ANSI establishes guidelines for safety eyewear, and classifies all lasers based on their potential for damage to eyes or tissue.

TROUBLESHOOTING:

PROBLEM	CAUSE	SOLUTION
The unit does not appear to have any power.	The unit is not plugged in	Make sure the main switch is off. Plug the unit into the wall supply. Turn the main switch and key switch on.
	The main switch is off	Press the main switch (I) on the back of the unit.
	The key switch is off	Insert the key and turn the switch to the "On" position.
The fan can be heard, but there is no display.	The emergency switch is engaged.	Rotate the emergency switch cap in the direction shown by the arrows on the cap. If the switch was engaged, the button should pop up.
	The cartridge lock is dislodged	Push the cartridge lock towards the side of the housing, and make sure it is fully seated against the side of the housing, and the back of the cartridge.
	Remote interlock loop is open.	If a connection is plugged into the Remote Interlock receptacle on the back of the laser, check to make sure the door is closed. If this does not solve the problem, briefly disconnect the remote interlock. If the unit's display illuminates, turn the unit off and do not use the laser until a qualified electrician can inspect the remote interlock switch connections.
No aiming beam is visible	Aiming beam is set too low	Press the "Aiming Beam" button to increase the aiming beam setting.
The foot pedal does not respond.	The laser is not in "Ready" mode	Look at the display, and make sure the "Ready" indicator is illuminated. If not, press the READY key.
	There are other wireless devices causing interference	Turn off the laser's key switch or main switch. Wait 1-2 minutes, then turn the unit on and try again. If this doesn't work, turn off the laser and move the laser and foot pedal to a different location in the room. Try changing the wireless channel.
	There are large metal surfaces between the laser and foot pedal	Turn off the laser and move the laser and foot pedal to a different location in the room, or remove the metal surface that is between the laser and foot pedal.
	The battery in the foot pedal is low.	Replace the battery.
Foot pedal beeps	Battery is low.	Replace the battery.
Display shows "Er" and the laser beeps continuously.	Program malfunction	Turn off the main switch or key switch immediately. Wait 1-2 minutes, and then turn the unit back on. If the error repeats, turn the unit off and contact the dealer or place of purchase.
Working beam indicator is lit, but the laser does not cut or seem to work	Power is set too low	Release the foot pedal, press "Ready" to place the laser out of ready status. Increase the working beam power setting, and then try again. If no results occur when the laser is set above 3 watts, turn the unit off and contact the dealer.
	Fiber connector is not properly engaged	Turn off the main power to the laser. See "Installing the Disposable Fiber Cartridge", and carry out steps 1, 2, 3, and 5. Then replace the connector going through steps, 3, then 2, then 1
	Fiber tip is blocked or dirty	Use the fiber cleaver to create a fresh, clean fiber end.
Power output indicated does not match the results from a power meter	Power meter is not appropriate for 810nm measurements.	Make sure the power meter used is rated to measure wavelengths in the 810nm range.
Fiber will not extend	Fiber cartridge is not seated properly.	Press down on the fiber cartridge, and make sure it is fully seated in the housing bay.
	Cartridge is out of fiber	Press the "Retract" and "Extend" buttons in that order, and confirm the fiber feed is still functional. If so, contact your dealer to order a replacement cartridge.

REORDER PART NUMBERS:

002-00246	Pioneer Pro 400 Micron Fiber Cartridge
002-00028	Fiber Stripper Tool
002-00027	Fiber Cleaving Tool
002-00271	Protective Glasses, Solid Sided
002-00272	Protective Glasses, Window Sided
002-00256	Package of (20) Handpiece Tips straight
002-00257	Package of (20) Handpiece Tips 60°
002-00025	Handpiece, autoclavable
002-00030	Laser Key
002-00247	Wireless Foot Pedal
002-00056	Wireless Receiver
01156	9 Volt Battery
002-00081	Power Cord
002-00034	Laser Safety Sign

**THIS PAGE INTENTIONALLY
LEFT BLANK**

**THIS PAGE INTENTIONALLY
LEFT BLANK**

Learn more about Pioneer Pro at www.pioneerlasers.com

PIONEER LASERS, LLC.
4628 West Skyhawk Drive
West Jordan, UT 84084

Call us toll free at 1-877-236-4402 in the U.S.

©2021 Pioneer Lasers, LLC. Pioneer Pro is a registered trademark of Pioneer Lasers, LLC.