

2022



For Maintenance and Safety

# OWNER'S MANUAL

PRO XD

**POLARIS**  
Think Outside



## WARNING

Read, understand, and follow all of the instructions and safety precautions in this manual and on all product labels.

Failure to follow the safety precautions could result in serious injury or death.



## WARNING

Operating, servicing, and maintaining a passenger vehicle or off-road vehicle can expose you to chemicals including engine exhaust, carbon monoxide, phthalates, and lead, which are known to the State of California to cause cancer and birth defects or other reproductive harm. To minimize exposure, avoid breathing exhaust, do not idle the engine except as necessary, service your vehicle in a well-ventilated area and wear gloves or wash your hands frequently when servicing your vehicle.

For more information go to [www.P65Warnings.ca.gov/passenger-vehicle](http://www.P65Warnings.ca.gov/passenger-vehicle).



*For videos and more information  
about a safe riding experience with  
your Polaris vehicle, scan this QR  
Code® with your smartphone.*



***2022 Owner's Manual***

***Pro XD Full-Size***

Unless noted, trademarks are the property of Polaris, Inc.

Loctite® is a registered trademark of Henkel Corporation. NYOGEL® is a registered trademark of Nye Lubricants, Inc. Tread Lightly® is a registered trademark of the United States Department of Agriculture. QR Code® is a registered trademark of DENSO WAVE INCORPORATED. WD-40® is registered to WD-40 Manufacturing Company. Bluetooth® is a registered trademark of Bluetooth Sig, Inc.

Copyright 2021 Polaris, Inc. All information contained within this publication is based on the latest product information at the time of publication. Due to constant improvements in the design and quality of production components, some minor discrepancies may result between the actual vehicle and the information presented in this publication. Depictions and/or procedures in this publication are intended for reference use only. No liability can be accepted for omissions or inaccuracies. Any reprinting or reuse of the depictions and/or procedures contained within, whether whole or in part, is expressly prohibited.

The original instructions for this vehicle are in English. Other languages are provided as translations of the original instructions.

Printed in U.S.A.

9940401 R02



Thank you for purchasing a POLARIS vehicle, and welcome to our world-wide family of POLARIS enthusiasts. Be sure to visit us online at [www.polaris.com](http://www.polaris.com) for the latest news, new product introductions, upcoming events, career opportunities and more.

Here at POLARIS we proudly produce an exciting line of utility and recreational products. We believe POLARIS sets a standard of excellence for all utility and recreational vehicles manufactured in the world today. Many years of experience have gone into the engineering, design, and development of your POLARIS vehicle.

For safe and enjoyable operation of your vehicle, be sure to follow the instructions and recommendations in this owner's manual. Your manual contains instructions for minor maintenance, but information about major repairs is outlined in the POLARIS Service Manual and can be performed by a factory certified Master Service Dealer (MSD) technician.

Your POLARIS dealer knows your vehicle best and is interested in your total satisfaction. Your POLARIS dealership can perform all of your service needs during and after the warranty period.

For the most up-to-date owner's manual visit <https://www.polaris.com/en-us/owners-manuals>.

WELCOME

---

---

<b>Introduction . . . . .</b>	<b>7</b>
<b>Safety . . . . .</b>	<b>11</b>
<b>Features and Controls . . . . .</b>	<b>31</b>
<b>Operation . . . . .</b>	<b>65</b>
<b>Winch Guide. . . . .</b>	<b>85</b>
<b>Emission Control Systems . . . . .</b>	<b>95</b>
<b>Maintenance . . . . .</b>	<b>97</b>
<b>Specifications . . . . .</b>	<b>151</b>
<b>POLARIS Products . . . . .</b>	<b>157</b>
<b>Troubleshooting . . . . .</b>	<b>159</b>
<b>Warranty . . . . .</b>	<b>163</b>
<b>Maintenance Log . . . . .</b>	<b>173</b>





# INTRODUCTION

## IMPORTANT INFORMATION

 **WARNING**

Failure to follow the warnings contained in this manual can result in severe injury or death.

This vehicle is not a toy and can be hazardous to operate. This vehicle handles differently than other vehicles. A collision or rollover can occur quickly, even during routine maneuvers, if you fail to take proper precautions.

- Read this owner's manual. Understand all safety warnings, precautions and operating procedures before operating the vehicle. Keep this manual with the vehicle at all times.
- This vehicle is an **ADULT VEHICLE ONLY**. You **MUST** be at least 16 years of age and have a valid driver's license to operate this vehicle.
- No person under the age of 12 may ride as a passenger in this vehicle.
- Never permit a guest to operate this vehicle unless the guest has read this manual and all product labels.
- Always keep hands, feet, and all other body parts inside the vehicle at all times.
- Always wear the proper clothing when operating or riding in this vehicle. All riders should wear substantial footwear, long pants, and a close-fitting shirt. A hard hat or helmet and approved eye protection are recommended when appropriate for riding or working conditions.
- Never operate this vehicle under the influence of drugs or alcohol, as these conditions impair judgement and the operator's ability to react.

## INTRODUCTION

---

### SAFETY SYMBOLS AND SIGNAL WORDS

The following signal words and symbols appear throughout this manual and on your vehicle. Your safety is involved when these words and symbols are used. Become familiar with their meanings before reading the manual.

#### DANGER

DANGER indicates a hazardous situation which, if not avoided, WILL result in death or serious injury.

#### WARNING

WARNING indicates a hazardous situation which, if not avoided, COULD result in death or serious injury.

#### CAUTION

CAUTION indicates a hazardous situation which, if not avoided, COULD result in minor to moderate injury.

#### NOTICE

NOTICE provides key information by clarifying instructions.

#### IMPORTANT

IMPORTANT provides key reminders during disassembly, assembly, and inspection of components.

The Prohibition Safety Sign indicates an action NOT to take in order to avoid a hazard.



The Mandatory Action Sign indicates an action that NEEDS to be taken to avoid a hazard.



## VEHICLE IDENTIFICATION NUMBERS

Record your vehicle's identification numbers in the spaces provided. The engine serial number is located on the side of the engine, below the injection pump.

All keys have the number 4083. Remove the spare key and store it in a safe place. Additional pre-cut keys for your vehicle can be ordered.

The engine serial number can be found on a decal applied to the front of the engine crankcase ① or stamped into the crankcase on the PTO side of the engine ②.

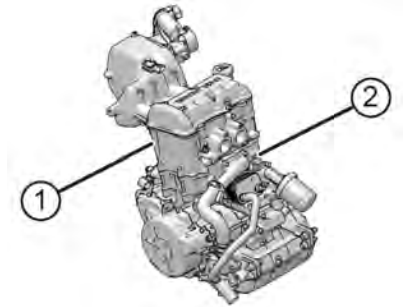

The VIN can be found stamped on a portion of the left rear frame ①, above the PVT cover.

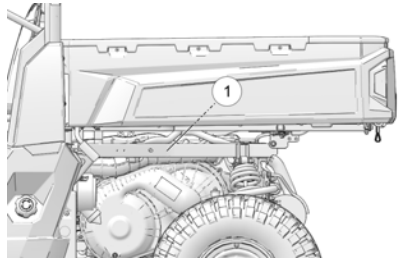

Vehicle Model Number	
Vehicle Identification Number (VIN) ①	
Engine Serial Number ②	
Key Number	4083



## SAFETY

### PERSONAL PROTECTIVE EQUIPMENT

Always wear the proper clothing when operating or riding in this vehicle. All riders should wear substantial footwear, long pants and a close-fitting shirt. A hard hat or helmet and approved eye protection are recommended when appropriate for working or riding conditions. POLARIS recommends wearing approved eye protection bearing markings such as VESC 8, V-8, Z87.1 or CE. Never operate or ride in this vehicle while barefoot or while wearing sandals or tennis shoes.

Workplace safety regulations may require the use of safety glasses, safety shoes and a hard hat or helmet. Familiarize yourself with local requirements, be prepared for operating conditions and wear the appropriate safety gear.

Department of Transportation (DOT) approved helmets are required for all riders when operating at 30 MPH or above. Approved helmets in the USA and Canada bear a U.S. Department of Transportation label.



### RIDER COMFORT

Under certain operating conditions, heat generated by the engine and exhaust system can elevate temperatures in the driver and passenger cab area. The condition occurs most frequently when a vehicle is being operated in high ambient temperatures at low speeds and/or high load conditions for an extended period of time. The use of certain windshield, roof and/or cab systems may contribute to this condition by restricting airflow. Any discomfort due to heat buildup in this area can be minimized by wearing proper riding apparel and by varying speeds to increase airflow.

## SAFETY

---

### SAFETY LABELS AND LOCATIONS

Warning labels have been placed on the vehicle for your protection. Read and follow the instructions of the labels on the vehicle carefully. If any of the labels depicted in this manual differ from the labels on your vehicle, always read and follow the instructions of the labels on the *vehicle*.

If an informational or graphic label becomes illegible or comes off, contact your POLARIS dealer to purchase a replacement. Replacement *safety* labels are provided by POLARIS at no charge. The part number is printed on the label.

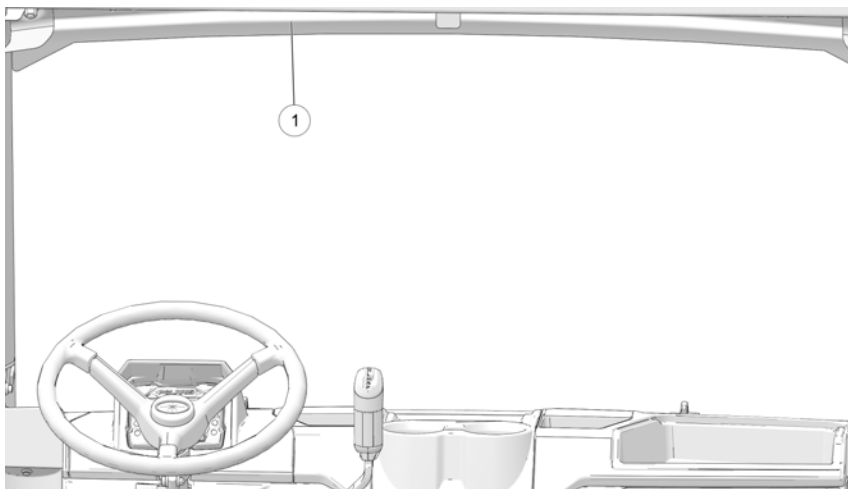

The seat belt/drive responsibly warning label, the proper use warning label, and the payload warning are located on the front ROPS, above the driver's head ①.

### SEAT BELT / DRIVE RESPONSIBLY WARNING

#### WARNING

**Part Number: 7300410**

**IMPROPER VEHICLE USE CAN RESULT IN SERIOUS INJURY OR DEATH**

**NEVER OPERATE:**

- At speeds too fast for your skills or the conditions.
- After or while using Alcohol or Drugs.
- Across slopes (Avoid side hilling).
- On public roads. This vehicle is for off-highway use only. Driving on public roads could be a violation of law and may be hazardous.

- With more passengers than described in the Operation & Maintenance Manual, with children under the age of 12, and passengers who cannot comfortably reach the floor and hand holds with back against the seat.
- With unapproved accessories - they may seriously affect stability.

### **LOCATE AND READ OPERATION & MAINTENANCE MANUAL. FOLLOW ALL INSTRUCTIONS AND WARNINGS.**

#### **ALWAYS:**

- Wear head protection - such as a hard hat or helmet - as appropriate for conditions and usage. Consult manual for more information.
- Wear your seatbelt. Vehicle rollover could cause serious injury or death.
- Wear eye protection and keep hands and feet in vehicle at all times.
- Reduce speed and use extra caution when carrying passengers.
- Avoid sharp turns or turns while applying heavy throttle.
- Operate slowly in reverse - avoid sharp turns or sudden braking.
- Make sure passengers read and understand all warning labels.
- Watch for branches or other hazards that could enter vehicle.
- Use caution while operating vehicle on private paved surfaces. Pavement can alter handling and may cause loss of control.

#### **Be Sure Riders Pay Attention and Plan Ahead**

If you think or feel the vehicle may tip or roll, reduce your risk to injury:

- Keep a firm grip on the steering wheel or handholds and brace yourself.
- Do not put any part of your body outside of the vehicle for any reason.

Rollovers have caused severe injuries and death, even on flat, open areas.

## PROPER USE WARNING (2-SEAT)

### WARNING

**Part Number: 7300098**

#### **Require Proper Use of Your Vehicle**

Do your part to prevent injuries:

- Do not allow careless or reckless driving.
- Make sure operators are 16 or older with a valid driver's license.
- Do not let people drive or ride after using alcohol or drugs.
- Do not allow operation on public roads (unless designated for off-highway vehicle access) - collisions with cars and trucks can occur.
- Do not exceed seating capacity: 2 occupants.

## PROPER USE WARNING (4-SEAT)

### WARNING

**Part Number: 7300099**

#### **Require Proper Use of Your Vehicle**

Do your part to prevent injuries:

- Do not allow careless or reckless driving.
- Make sure operators are 16 or older with a valid driver's license.
- Do not let people drive or ride after using alcohol or drugs.
- Do not allow operation on public roads (unless designated for off-highway vehicle access) - collisions with cars and trucks can occur.
- Do not exceed seating capacity: 4 occupants.



## PAYLOAD WARNING

### **⚠ WARNING**

Part Number: 7300640

WARNING		
MODEL	NEVER EXCEED	IF TOTAL PAYLOAD EXCEEDS
Full-Size Diesel	25 mph (40 kph)	860 lbs. (376 kg)
Full-Size Diesel Crew	25 mph (40 kph)	860 lbs. (376 kg)
Full-Size Gas	25 mph (40 kph)	1250 lbs. (567 kg)
Full-Size Gas Crew	25 mph (40 kph)	1250 lbs. (567 kg)

## FUEL TRANSPORT WARNING

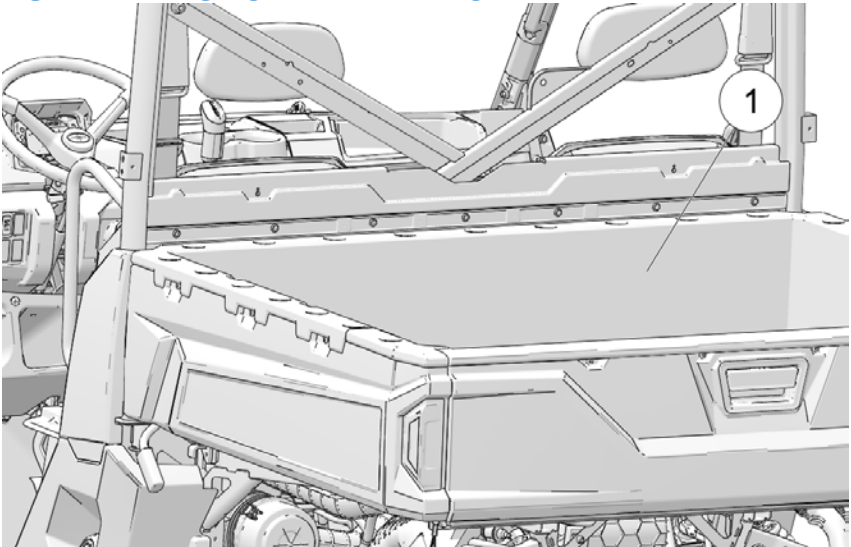

The fuel transport warning label ① is located in the cargo box.

### **⚠ WARNING**

Part Number: 7186122

NEVER carry fuel or other flammable liquids on this vehicle.

Failure to follow this instruction could lead to serious burn injuries or death.

# SAFETY

## LOAD/PASSENGER/TIRE PRESSURE WARNING

The load/passenger/tire pressure warning label is located next to the fuel transport warning label in the cargo box.

### WARNING

Part Number: 7300637

### WARNING

FALLING OFF CARGO BOX CAN CAUSE SERIOUS INJURY OR DEATH

- Never carry riders in cargo box.

OVERLOADING OR IMPROPER TIRE PRESSURE CAN CAUSE TIPPING OR LOSS OF CONTROL RESULTING IN SERIOUS INJURY OR DEATH

- Never exceed load capacities.
- Reduce speed and allow greater distance for braking when carrying cargo.
- Carrying tall, off-center, or unsecured loads will increase your risk of losing control. Center and secure loads as low as possible in box.
- Reduce speed and cargo on rough or hilly terrain.
- Check for proper tire pressures.

MODEL NUMBER	FULL-SIZE DIESEL	FULL-SIZE DIESEL CREW	FULL-SIZE GAS	FULL-SIZE GAS CREW
<b>MAXIMUM CARGO BOX LOAD</b>	1250 lbs. (566 kg)	1250 lbs. (566 kg)	1250 lbs. (566 kg)	1250 lbs. (566 kg)
<b>TIRE PRESSURE IN PSI (KPa)</b>	FRONT 24 (165) REAR 24 (165)	FRONT 24 (165) REAR 24 (165)	FRONT 5 (34) REAR 20 (138)	FRONT 10 (69) REAR 20 (138)
<b>VEHICLE RATED CAPACITY</b> INCLUDES WEIGHT OF OPERATOR, PASSENGER, CARGO, AND ACCESSORIES.	1900 lbs. (861 kg)	2075 lbs. (941 kg)	1900 lbs. (861 kg)	2075 lbs. (941 kg)

MODEL NUMBER	FULL-SIZE DIESEL	FULL-SIZE DIESEL CREW	FULL-SIZE GAS	FULL-SIZE GAS CREW
GVWR	3600 lbs. 1632 kg	4000 lbs. 1814 kg	3600 lbs. 1632 kg	4000 lbs. 1814 kg
Read Operation & Maintenance Manual for more detailed loading information.				

## CLUTCH COVER WARNING

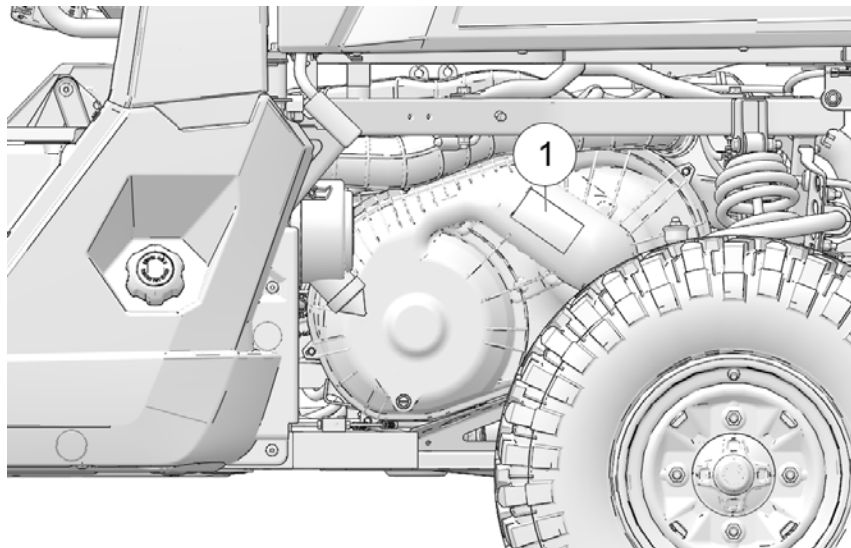

The clutch cover warning ① is located on the clutch cover.

### **⚠ WARNING**

**Part Number: 7182350**

Improper service or maintenance of this CVT system can result in vehicle damage, SEVERE INJURY or DEATH.

Always look for and remove debris inside and around clutch and vent system when replacing belt.

Read owner's manual or see an authorized service dealer.

## SAFETY

---

### SHIFT CAUTION

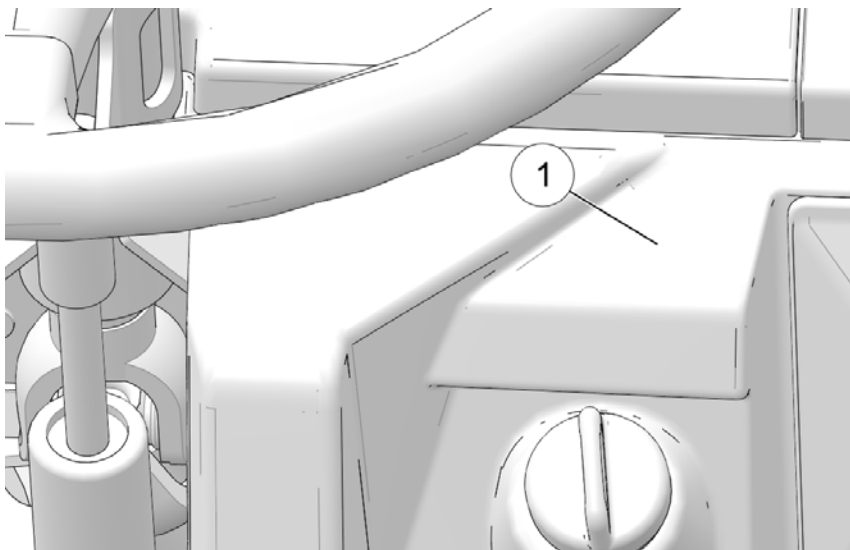

The shift caution ① is located above the ignition switch.

#### **⚠ CAUTION**

**Part Number: 7300087**

To avoid transmission damage, shift only when vehicle is stationary and at idle. When vehicle is stopped, place gear selector in PARK.

### TRAILER/HITCH CAPACITY

The trailer/hitch capacity label is located on the rear hitch bracket.

#### **⚠ CAUTION**

**Part Number: 7300095**

#### **CAUTION:**

HOT SURFACE. DO NOT TOUCH.

**TRAILER MAX. WEIGHT: 2500 LBS. (1134 kg)**

**HITCH MAX. VERTICAL WEIGHT: 250 LBS. (114 kg)**

---

## OPERATOR SAFETY

 **WARNING**

Serious injury or death can result if you do not follow these instructions and procedures, which are outlined in further detail within your owner's manual.

- Read this entire manual and all labels carefully. Follow the operating procedures described.
- Never allow anyone under the age of 16 to operate this vehicle and never allow anyone without a valid driver's license to operate this vehicle.
- Do not carry a passenger until you have at least two hours of driving experience with this vehicle.
- No person under the age of 12 may ride as a passenger in this vehicle.
- Always keep hands and feet inside the vehicle at all times. Always keep both hands on the steering wheel (driver) and both feet on the floorboards of the vehicle during operation.
- Never permit a guest to operate this vehicle unless the guest has read this manual and all product labels.
- Always make sure the seat belts are secured for operator and passenger before operating.
- Never exceed the stated load capacity for this vehicle. Cargo should be properly distributed and securely attached. Reduce speed and follow the instructions in this manual for hauling cargo or pulling a trailer. Allow a greater distance for braking.
- Always be sure there are no obstacles or people behind your vehicle when operating in reverse. When it's safe to proceed in reverse, move slowly. Avoid turning at sharp angles in reverse.
- Always use the proper size and type of tires specified in this manual. Always maintain proper tire pressure as specified on safety labels.
- Never modify this vehicle through improper installation or use of non-POLARIS-approved accessories.
- Always remove the key when leaving the vehicle unattended.
- Never consume alcohol or drugs before or while operating this vehicle.
- Never operate at excessive speeds. Always operate at a speed that's appropriate for the traffic, the visibility and operating conditions, your skills and your passengers' skills.
- Always inspect the vehicle before each use to make sure it's in safe operating condition. Always follow the inspection procedures described in this manual.
- Always travel slowly and use extra caution when operating on unfamiliar terrain. Be alert to changing terrain.
- Always follow proper procedures for turning. Make turns slowly, especially when the ground is wet, greasy, bumpy or sloping. Never turn the steering wheel abruptly when driving at high speed.

## SAFETY

---

- Always have this vehicle checked by an authorized POLARIS dealer if it has been involved in an accident.
- Always be alert for obstacles when operating this vehicle. Never attempt to operate over obstacles.
- Never operate this vehicle on steep hills.
- Never operate on excessively rough, slippery or loose terrain.
- Always be careful of skidding or sliding. On slippery surfaces such as ice, travel slowly and exercise caution to reduce the chance of skidding or sliding out of control.
- Always be sure there are no obstacles or people behind your vehicle when operating in reverse. When it's safe to proceed in reverse, move slowly. Avoid turning at sharp angles in reverse.
- Always stop the engine before refueling. Remove flammable material containers from the box before filling them with fuel. Make sure the refueling area is well ventilated and free of any source of flame or sparks.

## PROPER OPERATION

Failure to operate the vehicle properly can result in a collision, loss of control, accident or rollover, which may result in serious injury or death. Heed all safety warnings outlined in this section of the owner's manual. See the OPERATION section of the owner's manual for proper operating procedures.



## OPERATING WITHOUT INSTRUCTION

Operating this vehicle without proper instruction increases the risk of an accident. The operator must understand how to operate the vehicle properly in different situations and on different types of terrain. All operators must read and understand the Owner's Manual and all warning and instruction labels before operating the vehicle.



## AGE RESTRICTIONS

This vehicle is an **ADULT VEHICLE ONLY**. NEVER operate this vehicle if you are under age 16 and NEVER operate without a valid driver's license. Never operate with a passenger under the age of 12. All riders must be able to sit with backs against the seat, both feet flat on the floor and both hands on the steering wheel (if driving) or on a passenger hand hold (if equipped).



## SAFETY

---

### USING ALCOHOL OR DRUGS

Never consume alcohol or drugs before or while operating this vehicle.

Operating this vehicle after consuming alcohol or drugs could adversely affect operator judgment, reaction time, balance and perception.



### FAILURE TO INSPECT BEFORE OPERATING

#### WARNING

Failure to inspect and verify that the vehicle is in safe operating condition before operating increases the risk of an accident. Always perform the Pre-Ride Inspection outlined in the Operation chapter before each use of your vehicle to make sure it's in safe operating condition. Always follow the inspection and maintenance procedures and schedules described in this owner's manual. See the Periodic Maintenance section of the Maintenance chapter.

### SEAT BELTS

Riding in this vehicle without wearing the seat belt increases the risk of serious injury in the event of rollover, loss of control, other accident or sudden stop. Seat belts may reduce the severity of injury in these circumstances.

All riders *must* wear seat belts at all times.





## OPERATING WITH A LOAD ON THE VEHICLE

The weight of the cargo, operator, and passengers impacts vehicle operation and stability. For your safety and the safety of others, carefully consider how your vehicle is loaded and how to safely operate the vehicle. Follow the instructions in this manual for loading, tire pressure, gear selection and speed.

- **Do not exceed vehicle weight capacities.** The vehicle's maximum weight capacity is listed in the specifications section of this manual and on a label on the vehicle. When determining the weight you are adding to the vehicle, include the weight of the operator, passengers, accessories, loads in the rack or box and the load on the trailer tongue. The combined weight of these items must not exceed the maximum weight capacity.
- The recommended tire pressures are listed in the specifications section of this manual and on a label on the vehicle.

**Always follow these guidelines:**

UNDER ANY OF THESE CONDITIONS:	DO ALL OF THESE STEPS:
Operator and/or cargo exceeds half the maximum weight capacity	<ol style="list-style-type: none"> <li>1. Slow down.</li> <li>2. Verify tire pressure.</li> <li>3. Use extra caution when operating.</li> </ol>
Operating in rough terrain	
Operating over obstacles	
Climbing an incline	
Towing	

## IMPROPER TIRE MAINTENANCE

### WARNING

Operating this vehicle with improper tires or with improper or uneven tire pressure could cause loss of control or accident. Always use the size and type of tires specified for your vehicle. Always maintain proper tire pressure as described in the owner's manual and on safety labels.

## OPERATING AT EXCESSIVE SPEEDS

### CAUTION

Operating this vehicle at excessive speeds increases the operator's risk of losing control. Always operate at a speed that's appropriate for the terrain, the visibility and operating conditions and your skills and experience.

## SAFETY

---

### JUMPS AND STUNTS



Exhibition driving increases the risk of an accident or rollover. DO NOT do power slides, “donuts”, jumps or other driving stunts. Avoid exhibition driving.

### TURNING IMPROPERLY



Turning improperly could cause loss of traction, loss of control, accident or rollover. Always follow proper procedures for turning as described in this owner's manual.

Avoid sharp turns. Never turn while applying heavy throttle. Never make abrupt steering maneuvers. Practice turning at slow speeds before attempting to turn at faster speeds.

### IMPROPER HILL CLIMBING



Improper hill climbing could cause loss of control or rollover. Use extreme caution when operating on hills. Always follow proper procedures for hill climbing as described in this owner's manual.

### DESCENDING HILLS IMPROPERLY



Improperly descending a hill could cause loss of control or rollover. Always follow proper procedures for traveling down hills as described in this owner's manual.

### CROSSING HILLSIDES



Driving on a sidehill is not recommended. Improper procedure could cause loss of control or rollover. Avoid crossing the side of any hill unless absolutely necessary. If crossing a hillside is unavoidable, always follow proper procedures as described in this owner's manual.

## STALLING WHILE CLIMBING A HILL

### CAUTION

Stalling or rolling backwards while climbing a hill could cause a rollover.  
Maintain a steady speed when climbing a hill.

*If you lose all forward speed:*

Apply the brakes gradually until the vehicle is fully stopped. Place the transmission in reverse and slowly allow the vehicle to roll straight downhill while applying light brake pressure to control speed.

*If you begin rolling downhill:*

Never apply engine power. Apply the brakes gradually until the vehicle is fully stopped. Place the transmission in reverse and slowly allow the vehicle to roll straight downhill while applying light brake pressure to control speed.

## OPERATING IN UNFAMILIAR TERRAIN

### CAUTION

Failure to use extra caution when operating on unfamiliar terrain could result in an accident or rollover.

### CAUTION

Unfamiliar terrain may contain hidden rocks, bumps, or holes that could cause loss of control or rollover.

Travel slowly and use extra caution when operating on unfamiliar terrain. Always be alert to changing terrain conditions.

## OPERATING IMPROPERLY IN REVERSE

### CAUTION

Improperly operating in reverse could result in a collision with an obstacle or person. Always follow proper operating procedures as outlined in this manual.

Before shifting into reverse gear, always check for obstacles or people behind the vehicle. When it's safe to proceed, back slowly.

## SAFETY

---

### SKIDDING OR SLIDING

#### CAUTION

Failure to use extra caution when operating on excessively rough, slippery or loose terrain could cause loss of traction, loss of control, accident or rollover. Do not operate on excessively slippery surfaces. Always slow down and use additional caution when operating on slippery surfaces.

#### CAUTION

Skidding or sliding due to loss of traction can cause loss of control or rollover (if tires regain traction unexpectedly). Always follow proper procedures for operating on slippery surfaces as described in this owner's manual.

### OPERATING OVER OBSTACLES

#### CAUTION

Improperly operating over obstacles could cause loss of control or rollover. Before operating in a new area, check for obstacles. Avoid operating over large obstacles such as large rocks and fallen trees. Always follow the proper procedures outlined in this manual when operating over obstacles.

### OPERATING THROUGH WATER

#### CAUTION

Operating through deep or fast-flowing water can cause loss of traction, loss of control, rollover or accident. Never operate in fast-flowing water or in water that exceeds the floor level of the vehicle.

Always follow proper procedures for operating in water as described in this owner's manual.

Wet brakes will have reduced stopping ability. After leaving water, test the brakes. Apply them lightly several times while driving slowly. The friction will help dry out the pads.

## OPERATING ON FROZEN BODIES OF WATER

### WARNING

Serious injury or death can result if the vehicle and/or the operator fall through the ice. Never operate the vehicle on a frozen body of water unless you have first verified that the ice is sufficiently thick to support the weight and moving force of the vehicle, you and your cargo, together with any other vehicles in your party.

Always check with local authorities and residents to confirm ice conditions and thickness over your entire route. Vehicle operators assume all risk associated with ice conditions on frozen bodies of water.

## OPERATING A DAMAGED VEHICLE

### CAUTION

Operating a damaged vehicle can result in an accident. After any rollover or other accident, have a qualified service dealer inspect the entire machine for possible damage, including (but not limited to) seat belts, rollover protection devices, brakes, throttle, and steering systems.

## IMPROPER CARGO LOADING

Overloading the vehicle or carrying cargo improperly may cause changes in stability and handling, which could cause loss of control or an accident.

- Always follow the instructions in this owner's manual for carrying cargo.
- Never exceed the stated load capacity for this vehicle.
- Cargo should be properly distributed and securely attached.
- Reduce speed when carrying cargo or pulling a trailer. Allow a greater distance for braking.

## POOR VISIBILITY

### CAUTION

Operating this vehicle in darkness or inclement weather could result in a collision or accident, especially if operating on a road or street. This vehicle is not equipped with highway-approved lights. Operate this vehicle off-road only. Use caution and drive at reduced speeds in conditions of reduced visibility such as fog, rain and darkness. Clean headlights frequently and replace burned out headlamps promptly.

### HOT EXHAUST SYSTEMS

#### WARNING

Exhaust system components are very hot during and after use of the vehicle. Hot components can cause burns and fire. Do not touch hot exhaust system components. Always keep combustible materials away from the exhaust system.

Use caution when traveling through tall grass, especially dry grass and when traveling through muddy conditions. Always inspect the underside of the vehicle and areas near the exhaust system after driving through tall grass, weeds, brush, other tall ground cover, and muddy conditions. Promptly remove any grass, debris or foreign matter clinging to the vehicle and pay particular attention to the exhaust system area.



### EXPOSURE TO EXHAUST

#### CAUTION

Engine exhaust fumes are poisonous and can cause loss of consciousness or death in a short time. Never start the engine or let it run in an enclosed area. Operate this vehicle only outdoors or in well-ventilated areas.

### UNAUTHORIZED USE OF THE VEHICLE

Leaving the keys in the ignition can lead to unauthorized use of the vehicle by someone under the age of 16, without a drivers license, or without proper training. This could result in an accident or rollover. Always remove the ignition key when the vehicle is not in use.

---

## EQUIPMENT MODIFICATIONS

Your POLARIS vehicle is designed to provide safe operation when used as directed. Modifications to your vehicle may negatively impact vehicle stability. Failure of critical machine components may result from operation with any modifications, especially those that increase speed or power. This vehicle may become less stable at speeds higher than those for which it is designed. Loss of control may occur at higher speeds.

Do not install any non-POLARIS-approved accessory or modify the vehicle for the purpose of increasing speed or power. Any modifications or installation of non-POLARIS-approved accessories could create a substantial safety hazard and increase the risk of bodily injury.

The POLARIS limited warranty on your POLARIS vehicle will be terminated if any non-POLARIS approved equipment and/or modifications have been added to the vehicle that increase speed or power.

The addition of certain accessories, including (but not limited to) mowers, blades, tires, sprayers, or large racks, may change the handling characteristics of the vehicle. Use only POLARIS-approved accessories, and familiarize yourself with their function and effect on the vehicle.

The addition of certain accessories, including (but not limited to) overhead audio speakers, may change the forward clearance in the vehicle. Polaris recommends selecting a helmet that is compatible with the equipment on your vehicle and provides the greatest amount of forward clearance. Always wear a helmet that meets or exceeds the specifications in this owner's manual. Refer to the Safe Riding Gear section of this owner's manual for more information. Use only POLARIS-approved accessories.

**FOR MORE INFORMATION ABOUT SAFETY IN THE UNITED STATES call POLARIS at 1-800-342-3764.**





# FEATURES AND CONTROLS

## COMPONENT LOCATIONS

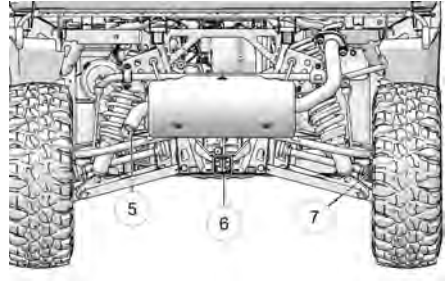
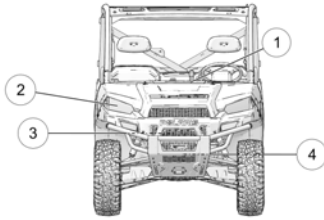

- ① Console
- ② Headlights
- ③ Radiator
- ④ Front Bumper / Brush Guard

- ⑤ Muffler (Spark Arrester)
- ⑥ Receiver Hitch
- ⑦ CV Boot / Rear Caliper

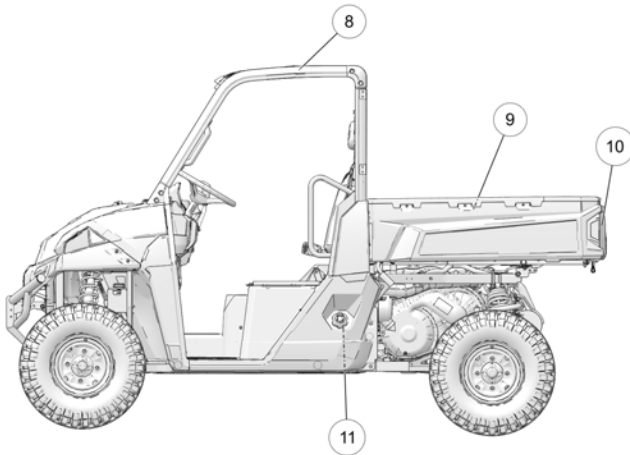

- ⑧ ROPS Cab Frame
- ⑨ Cargo Box
- ⑩ Tailgate
- ⑪ Fuel Cap

### CONSOLE

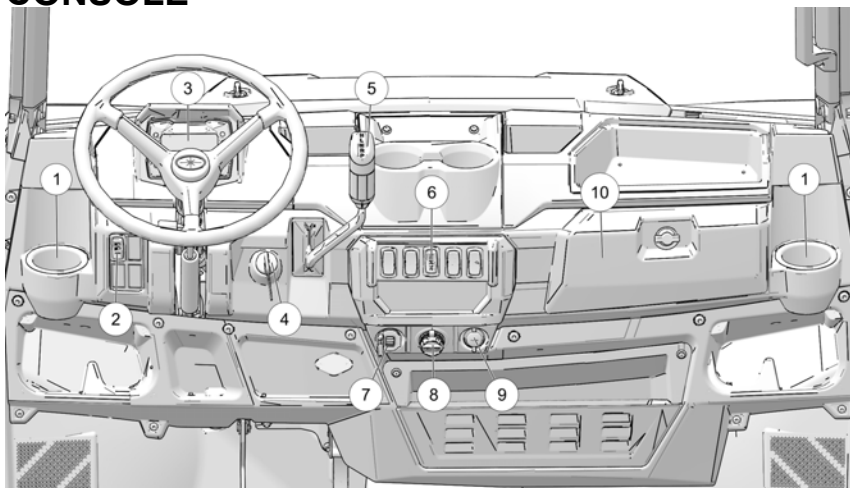

- ① Cup Holder
- ② Light Switch
- ③ Instrument Cluster
- ④ Ignition Switch
- ⑤ Gear Selector (Shifter)
- ⑥ AWD Switch
- ⑦ USB Charging Outlets
- ⑧ Battery Trickle Charging Outlet
- ⑨ Auxiliary Outlet
- ⑩ Storage Compartment

### USB OUTLETS

The USB outlets can be used to power accessories like a cell phone charger or a Bluetooth® speaker.

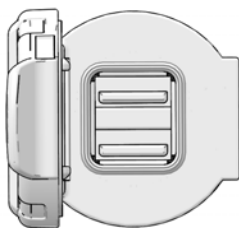

### BATTERY TRICKLE-CHARGING OUTLET

The vehicle is equipped with a dedicated outlet for trickle-charging the battery during periods of extended inactivity.

If you do not drive the vehicle for more than TWO WEEKS, Polaris recommends using a BatteryMINDer® 2012 AGM - 2 AMP charger, which can be ordered through your dealer, if available.

Polaris provides a charging accessory with your vehicle that allows easy connection to the battery through the Battery Trickle-Charging Outlet, located on the dash. While charging, place the charger outside of the vehicle and protect it from moisture.



### AUXILIARY OUTLET

The auxiliary outlet can be used to power standard 12V accessories like a cell phone charger or a power inverter up to 120 watts. Crew models have a second auxiliary outlet on switched power located in the center console between the rear seats. The passenger side outlet (and the rear outlet on crew models) switch on and off with the vehicle. These outlets cannot be used to charge the battery because they disconnect when the vehicle is off.



### ADJUSTABLE STEERING WHEEL

The steering wheel can be tilted upward or downward for rider preference. Lift and hold the adjustment lever ① toward you while moving the steering wheel upward or downward. Release the lever when the steering wheel is at the desired position.

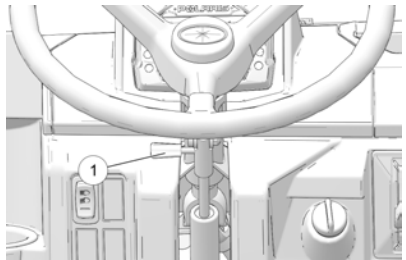

## FEATURES AND CONTROLS

---

### GEAR SELECTOR

Low gear is the primary driving range for the *PRO XD*. High gear is intended for use on hard-packed surfaces with light loads. Using high gear for heavy loads, hilly terrain or in wet, muddy conditions will increase the chance of drive belt spinning. An alarm will sound if the vehicle detects belt spin. See the Drive Belt Wear/Spin section on page 159.

H: High Gear

L: Low Gear

N: Neutral

R: Reverse

P: Park

To shift gears, brake to a complete stop. When the engine is idling, move the lever to the desired gear.

#### NOTICE

Shifting gears with the engine speed above idle or while the vehicle is moving could cause transmission damage. Always shift when the vehicle is stationary and the engine is at idle.

#### TIP

Maintaining shift linkage adjustment is important to assure proper transmission function. See your dealer if you experience any shifting problems.

### **USING LOW RANGE**

Always shift into low gear for any of the following conditions.

- Operating in rough terrain or over obstacles
- Loading the vehicle onto a trailer
- Towing loads
- Driving frequently at low RPM or at ground speeds below 7 mph (11 km/h)

### **REVERSE ALERT BEEPER (IF EQUIPPED)**

Putting the vehicle into reverse will automatically activate the reverse alert beeper.

## SWITCHES

### IGNITION SWITCH

The ignition switch is a three-position, key-operated switch. The key can be removed from the switch when it is in the OFF position.

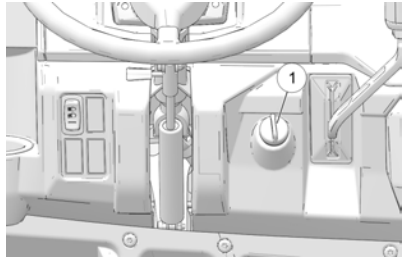

OFF	The engine is off. Electrical circuits are off, except for the driver's side auxiliary outlet and the Pulse Bar.
ON	Electrical circuits are on. Electrical equipment can be used.
START	Turn the key to the START position to engage the electric starter. The key returns to the ON position when released.

### LIGHT SWITCH

The ignition switch key must be in the ON/RUN position to operate the headlights. Press the top of the switch to place the headlights on high beam. Move the switch to the center position to place the headlights on low beam. Press the bottom of the switch to turn off the headlights.



## FEATURES AND CONTROLS

### DRIVELINE MODE SWITCH

The Driveline Mode Switch has three positions: All Wheel Drive (AWD), Differential Lock/Two Wheel Drive (2WD) and Off (Turf Mode).

- ① **AWD:** Press the top of the switch to engage All Wheel Drive (AWD).
- ② **2WD:** Move the switch to the center position to lock the differential and operate in two wheel drive (2WD).
- ③ **TURF Mode:** Press the bottom of the switch for Turf Mode (unlocked differential power). In Turf Mode, the rear drive wheels operate independently (1WD) depending on tire traction. This mode of operation is well suited to turf driving or when active traction is not needed.

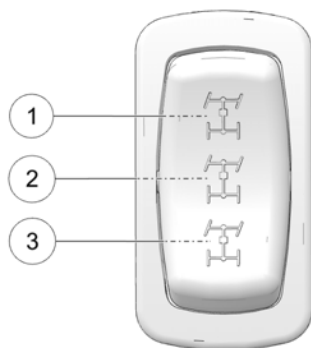

### HEATER CONTROL PANEL (IF EQUIPPED)

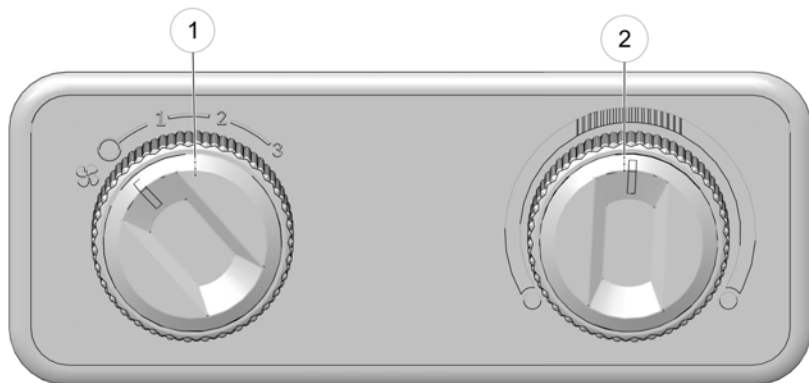

To operate the cab heater, rotate the fan control ① to the desired fan speed setting. The far left setting turns the fan off. Adjust the temperature by rotating the temperature control ② to the desired heat setting. Rotate the control clockwise to increase heat or counter-clockwise to decrease heat.

### PULSE BAR

The Pulse Bar ① is located under the hood and can be used to connect any Pulse Bar accessory to the vehicle. The Pulse Bar receives constant and switched power from the battery, so that accessories may be powered whether the vehicle is on or off.

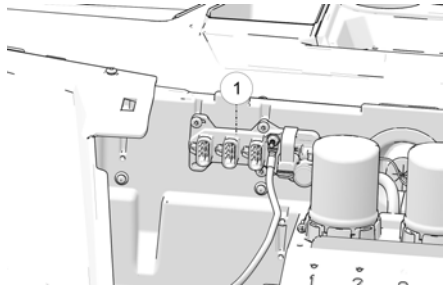

### FOOT PEDALS

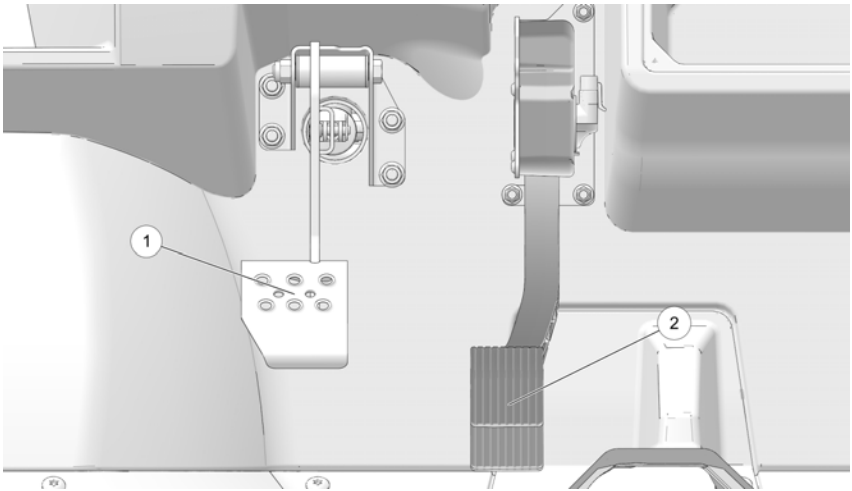

### BRAKE PEDAL

Depress the brake pedal ① to slow or stop the vehicle. Apply the brakes while starting the engine.

When the brake pedal is depressed, the brake light comes on. Check the brake light before each ride.

1. Turn the ignition switch to the ON position.
2. Apply the brakes. The brake light should come on after about 0.4 in (10 mm) of pedal travel.

## FEATURES AND CONTROLS

---

### THROTTLE PEDAL

Push the throttle pedal ② down to increase engine speed. Spring pressure returns the pedal to the rest position when released. Always check that the throttle pedal returns normally before starting the engine.

### TRAILER HITCH BRACKET

This vehicle is equipped with a receiver hitch bracket for a trailer hitch. Trailer towing equipment is not supplied with this vehicle.

To avoid injury and property damage, always heed the warnings and towing capacities.

### SEAT AND STORAGE COMPARTMENTS

The electrical compartment is located under the center rear-most seat. Never use this area for storage. Storage compartments are located under all other seats. Remove the storage bin under the right rear-most passenger seat to access the battery.

Always make sure all seats are properly installed before operating. Push down firmly on the rear of each seat until the latch pins are fully seated into the grommets.

### DRIVER'S SEAT

To access the storage area under the driver's seat, reach behind the driver's seat and pull up on the latch. Roll the bottom of the seat forward toward steering wheel.

### PASSENGER'S SEAT

To access the storage area under the passenger seat, lift up on the front of the passenger seat and raise it to the upright position.



### **ELECTRONIC POWER STEERING (EPS) (IF EQUIPPED)**

Electronic power steering engages when the ignition key is turned to the ON position. EPS remains engaged whether the vehicle is moving or idle.

To conserve battery power, the EPS will shut down 5 minutes after the engine is stopped if the key remains in the ON position. The EPS warning indicator will illuminate to indicate the EPS has shut down. See your POLARIS dealer, or other qualified person, as soon as possible for repair. Continued operation could result in permanent damage to the EPS unit and increased steering effort.

### **BELT SPIN ALARM**

The Belt Spin Alarm will sound if the vehicle senses or detects belt spin (engine RPM without ground speed). The instrument cluster will also scroll the message "belt damage occurring". If the alarm continues to sound frequently, shift to low gear.

### **FUEL CAP**

The fuel tank filler cap ① is located on the left-hand side of the vehicle near the driver's seat. To close, tighten the fuel cap until it clicks twice. When refueling, always use either leaded or unleaded gasoline with a minimum pump octane number of 87 R+M/2 octane. Do not use fuel with ethanol content greater than 10 percent, such as E-85 fuel. Always ensure that the fuel tank filler cap is fully tightened and secure before operating or transporting the vehicle.

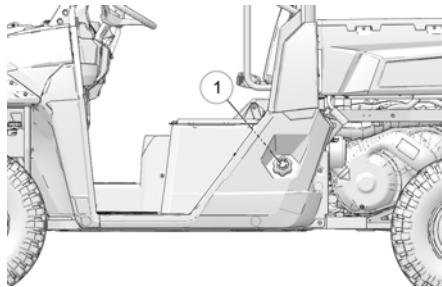

## FEATURES AND CONTROLS

---

### **OCCUPANT PROTECTION STRUCTURE (OPS)**

The Occupant Protection Structure (OPS) on this vehicle meets ANSI/OPEI B71.9 standards. Always have your authorized dealer thoroughly inspect the OPS if it ever becomes damaged in any way.

*No device can assure occupant protection in the event of a rollover. Always follow all safe operating practices outlined in this manual to avoid vehicle rollover.*



Vehicle rollover could cause serious injury or death. Always avoid operating in a manner that could result in vehicle rollover.

### **HOOD LATCHES**

To remove the hood, rotate the hood latches ① 1/4-turn and lift the hood away from the vehicle.

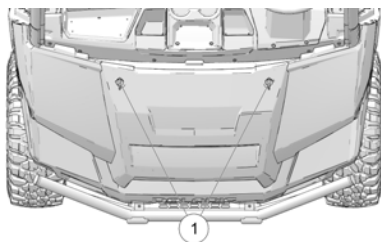



### SEAT BELTS

This POLARIS vehicle is equipped with three-point lap and diagonal seat belts on all seats. Always make sure the seat belts are secured for all riders before operating. The driver's seat belt is equipped with a seat belt interlock. Vehicle speed will be limited to 15 mph (24 km/h) if the seat belt is not secured.

#### WARNING

Falling from a moving vehicle could result in serious injury or death. Always fasten your seat belt securely before operating or riding.

To wear the seat belt properly, follow this procedure:

1. For 3-point belts with D loops , pull the seat belt latch downward and across your chest toward the buckle  at the inner edge of the seat. The belt should fit snugly across your hips and diagonally across your chest. Make sure the belt is not twisted.
2. Push the latch plate into the buckle until it clicks.
3. Release the strap, it will self-tighten.
4. To release the seat belt, press the square red button in the buckle's center.

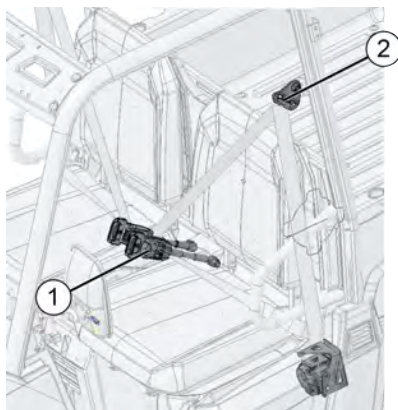

### SEAT BELT INSPECTION

Inspect all seat belts for proper operation before each use of the vehicle.

1. Push the latch plate into the buckle until it clicks. The latch plate must slide smoothly into the buckle. A click indicates that it's securely latched.
2. Push the red release latch in the middle of the buckle to make sure it releases freely.
3. Pull each seat belt completely out and inspect the full length for any damage, including cuts, wear, fraying or stiffness. If any damage is found, or if the seat belt does not operate properly, have the seat belt system checked and/or replaced by an authorized POLARIS dealer.
4. To clean dirt or debris from the seat belts, sponge the straps with mild soap and water. Do not use bleach, dye or household detergents.

## INSTRUMENT CLUSTER

### OVERVIEW

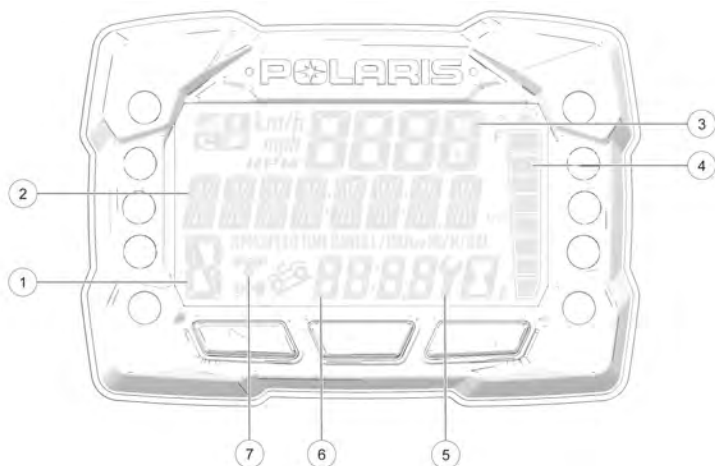

#### NOTICE



The use of a high pressure washer may damage the instrument cluster. Wash the vehicle by hand or with a garden hose using mild soap. Do not use alcohol to clean the instrument cluster. Do not allow insect sprays to contact the lens. Immediately clean off any gasoline that splashes on the instrument cluster.

DISPLAY AREA	FUNCTION
① Gear Indicator	H = High Gear L = Low Gear N = Neutral R = Reverse Gear P = Park – = Gear Signal Error (or shifter between gears)
② Display Area 2	This area displays odometer, trip meter, trip meter 2, voltage, engine temperature, engine hour meter, programmable service hour interval, ground speed, or engine RPM.
③ Display Area 1	This area displays engine RPM, ground speed, or coolant temperature.



## FEATURES AND CONTROLS

DISPLAY AREA	FUNCTION
④ Fuel Gauge	The segments of the fuel gauge show the level of fuel in the fuel tank. When the last segment clears, a low fuel warning is activated. All segments including the fuel icon will flash. Refuel immediately.
⑤ Service Indicator	A flashing wrench symbol alerts the operator that the preset service interval has been reached. Your POLARIS dealer can provide scheduled maintenance. See page 55 for more information.
⑥ Clock (if equipped)	The clock displays time in a 12-hour or 24-hour format.
⑦ AWD Indicator	Segments of the indicator illuminate based on drive mode engaged.

## INDICATOR LAMPS

Indicator	Icon	Function
Check Engine		This lamp illuminates when the ECM detects a Diagnostic Trouble Code in the engine management system. Do not operate the vehicle if this warning appears. Serious engine damage could result. Your authorized POLARIS dealer can assist. This lamp will also illuminate if the vehicle is keyed on but not started; it will turn off once the vehicle is started.
EPS Warning (if equipped)		This lamp illuminates to indicate that EPS has shut down. EPS shuts down automatically 5 minutes after the engine is turned off if the key remains in the ON position. Turn the key off and on to reset the unit. If the light remains on after starting the engine, the EPS system is inoperative. Your POLARIS dealer can assist.
Engine Hot		This lamp illuminates to indicate an overheated engine. If the indicator flashes, a severe overheating condition exists and the engine will shut down automatically. The vehicle will not start again until the engine has sufficiently cooled down. Whenever this lamp illuminates, the engine load should be reduced in any way possible to avoid overheating and shutting down the engine.

## FEATURES AND CONTROLS

Helmet/Seat Belt		This lamp flashes for several seconds when the key is turned to the ON position. The lamp will keep flashing as long as riders' seat belts are not connected.
High Beam		This lamp illuminates when the headlamp switch is set to high beam.

DISPLAY AREA 1

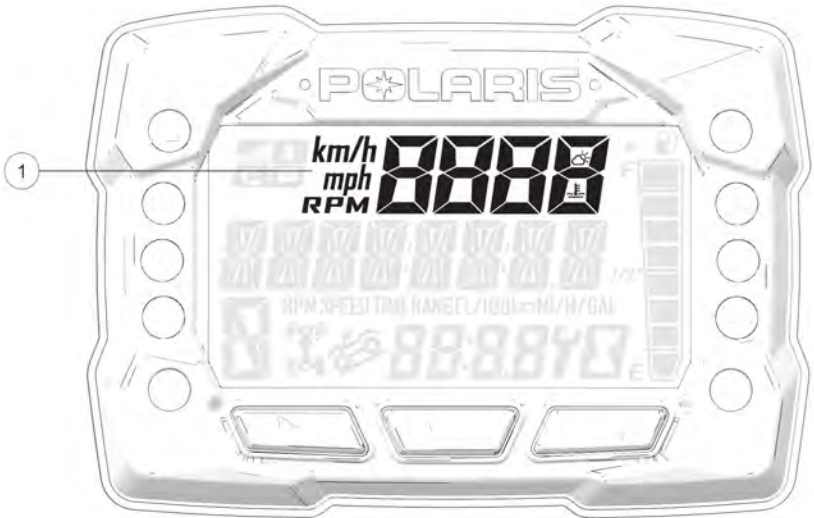

Pressing the MODE button will change the information displayed in Area 1 ①.

Speed



Engine Temperature



RPM



Ambient Temperature (Optional)



## FEATURES AND CONTROLS

### DISPLAY AREA 2

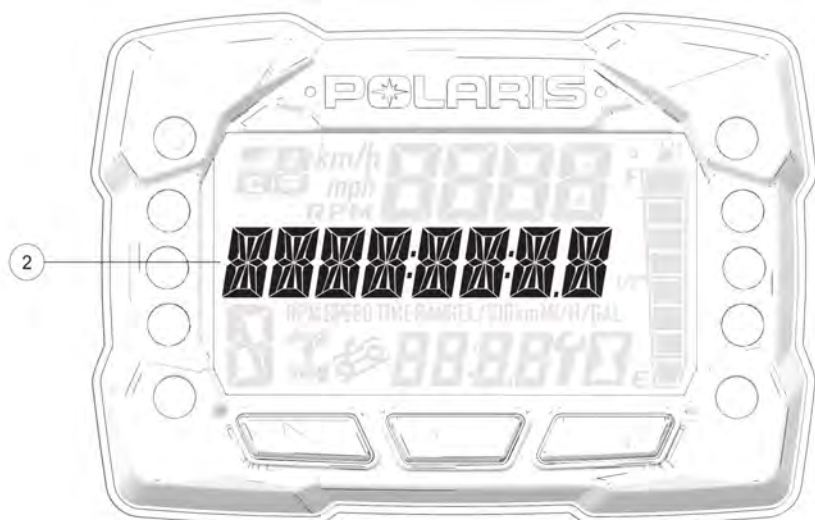

Toggle the Up/Down buttons to change the information displayed in Area 2 ②.

#### Odometer



#### Engine Temperature



#### Trip 1



#### Ambient Temperature (Optional)





Trip 2



RPM



Voltage



Speed



Engine Hours



Service Hours



### OPTIONS MENU



Press and hold the MODE button to enter the Options Menu.

OPTIONS MENU	NOTES
Diagnostic Codes	Only displays if fault codes are present or stored
Units - Distance	Select MPH or KPH
Units - Temp	Select between °F and °C
Clock	Select between 12H or 24H, and set time
Backlight Color	Select between Blue or Red
Backlight Level	Set backlight brightness level
Service Hours	View/Set Service hours
Speed Limiting(if equipped)	Set max speed
Exit Menu	Exit

**UNIT SELECTION DISTANCE**

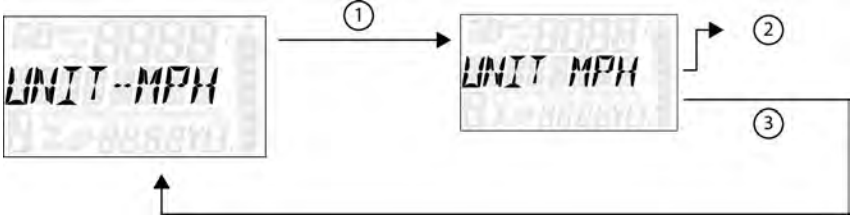

1. Press and hold the MODE button to enter the Options Menu.

**NOTICE**

"OPTIONS" will display on the screen for 3 seconds before showing first menu item.

2. Select "Units-Distance" from the Options Menu by pressing the MODE button.

Reference the image shown above:

- ① Press the MODE button.
- ② Toggle the Up/Down Buttons to change the units (MPH or KPH)
- ③ With the correct unit displayed, Press the mode button which will set the unit and return to the Options Menu.

3. To exit the Options Menu the user can select Exit Menu function from Options Menu, can hold Mode Button and exit out of Options Menu, or not press any button for 10 seconds, which will exit out of the Options Menu.

## FEATURES AND CONTROLS

### UNIT SELECTION TEMPERATURE

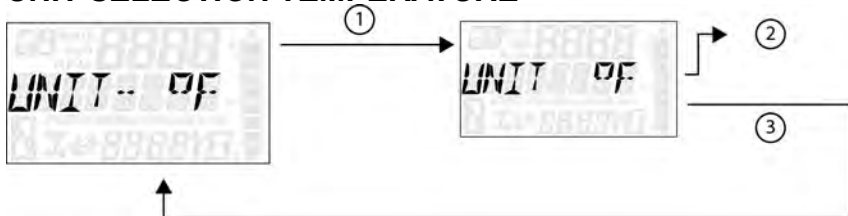

1. Press and hold the MODE button to enter the Options Menu.

#### NOTICE

"OPTIONS" will display on the screen for 3 seconds before showing first menu item.

2. Select "Units - Temp" from the Options Menu by pressing the MODE button.

Reference the image shown above:

- ① Press the MODE button.
  - ② Toggle the Up/Down Buttons to change the units (°F or °C)
  - ③ With the correct unit displayed, Press the mode button which will set the unit and return to the Options Menu.
3. To exit the Options Menu the user can select Exit Menu function from Options Menu, can hold Mode Button and exit out of Options Menu, or not press any button for 10 seconds, which will exit out of the Options Menu.

**CLOCK**

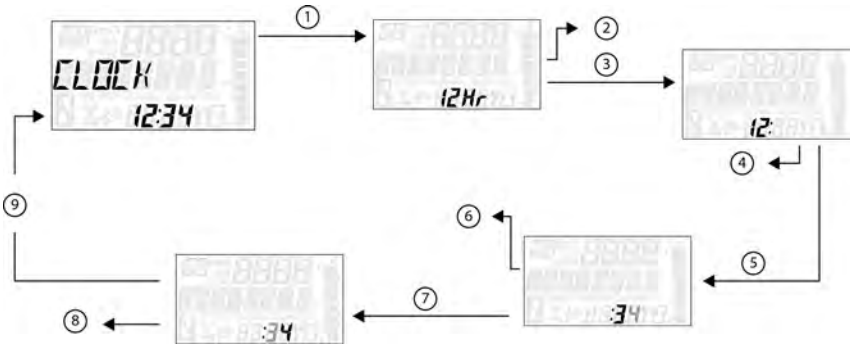

1. Press and hold the MODE button to enter the Options Menu.

**NOTICE**

"OPTIONS" will display on the screen for 3 seconds before showing first menu item.

## FEATURES AND CONTROLS

---

2. Select "Clock" from the Options Menu by pressing the MODE button.

Reference the image shown above:

- ① Press the MODE button.
  - ② Toggle the Up/Down Buttons to change the units (12H or 24H)
  - ③ With the correct unit displayed, Press the mode button which will set the unit.
  - ④ Toggle the Up/Down Buttons to change the units (Cycles Hours)
  - ⑤ With the correct unit displayed, Press the mode button which will set the unit.
  - ⑥ Toggle the Up/Down Buttons to change the units (Cycles 10s of Minutes)
  - ⑦ With the correct unit displayed, Press the mode button which will set the unit.
  - ⑧ Toggle the Up/Down Buttons to change the units (Cycles 1s of Minutes)
  - ⑨ With the correct unit displayed, Press the mode button which will set the unit and return to the Options Menu.
3. To exit the Options Menu the user can select Exit Menu function from Options Menu, can hold Mode Button and exit out of Options Menu, or not press any button for 10 seconds, which will exit out of the Options Menu.

**BACK LIGHT COLOR**

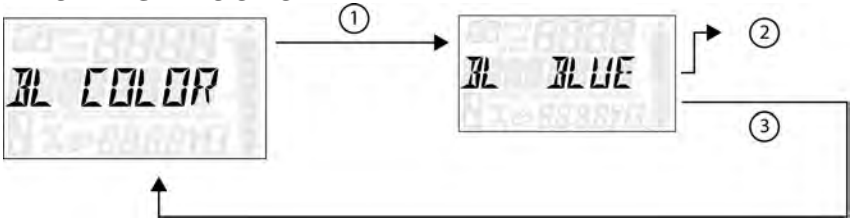

1. Press and hold the MODE button to enter the Options Menu.

**NOTICE**

“OPTIONS” will display on the screen for 3 seconds before showing first menu item.

2. Select “Backlight Color” from the Options Menu by pressing the MODE button.

Reference the image shown above:

- ① Press the MODE button.
- ② Toggle the Up/Down Buttons to change the units (Blue or Red)
- ③ With the correct unit displayed, Press the mode button which will set the unit and return to the Options Menu.

3. To exit the Options Menu the user can select Exit Menu function from Options Menu, can hold Mode Button and exit out of Options Menu, or not press any button for 10 seconds, which will exit out of the Options Menu.

### **BACK LIGHT LEVEL**

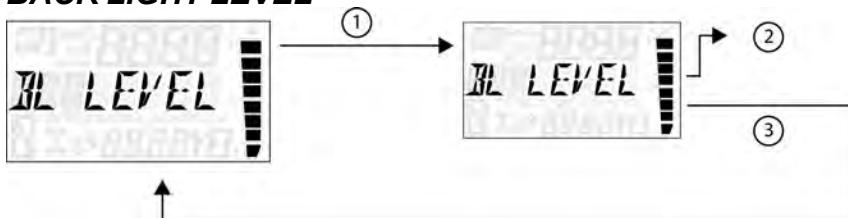

1. Press and hold the MODE button to enter the Options Menu.

#### **NOTICE**

"OPTIONS" will display on the screen for 3 seconds before showing first menu item.

2. Select "Backlight Level" from the Options Menu by pressing the MODE button.

Reference the image shown above:

- ① Press the MODE button.
  - ② Toggle the Up/Down Buttons to change the units (Increase or Decrease Level)
  - ③ With the correct unit displayed, Press the mode button which will set the unit and return to the Options Menu.
3. To exit the Options Menu the user can select Exit Menu function from Options Menu, can hold Mode Button and exit out of Options Menu, or not press any button for 10 seconds, which will exit out of the Options Menu.



## SERVICE HOURS

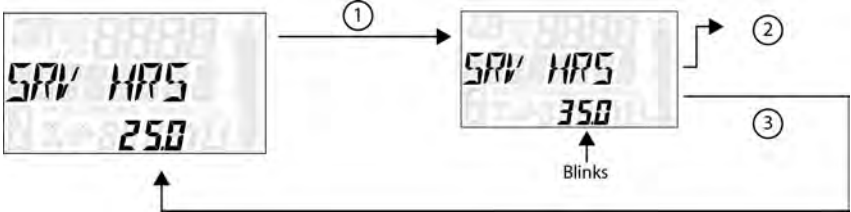

1. Press and hold the MODE button to enter the Options Menu.

### NOTICE

"OPTIONS" will display on the screen for 3 seconds before showing first menu item.

2. Select "Service Hours" from the Options Menu by pressing the MODE button.  
Reference the image shown above:

- ① Press the MODE button.
- ② Toggle the Up/Down Buttons to change the units (0, 5, 10 - 95, 100)
- ③ With the correct unit displayed, press the MODE button, which will set the unit and return you to the Options Menu.

### NOTICE

To reset service hours after they have counted down to "0.0", reselect the existing setpoint or select a new service hour value.

3. To exit the Options Menu the user can select Exit Menu function from Options Menu, can hold Mode Button and exit out of Options Menu, or not press any button for 10 seconds, which will exit out of the Options Menu.

## FEATURES AND CONTROLS

---

### **ADJUSTABLE SPEED LIMITING**



1. Press and hold the MODE button to enter the Options Menu.
2. Use the up and down buttons to navigate to SPD LMT and select it by pressing the MODE button.
3. ENTER PIN will scroll across the screen. Enter the 4-digit PIN by using the up and down buttons to change the digits and the MODE button to select each digit.
4. If the wrong PIN is entered, the screen will read WRONG PIN before going back to the ENTER PIN screen. If you forget your PIN, your authorized POLARIS dealer can provide assistance.
5. If the correct PIN is entered, you will enter the Adjustable Speed Limiting menu. The screen will read MAX SPEED and will either display the currently set max speed or the word OFF if there is no max speed currently set. From here, you can use the up and down buttons to navigate to the CHANGE PIN screen and the EXIT screen. (If you want to exit the Adjustable Speed Limiting Menu, press the MODE button on the EXIT screen.)

#### NOTE

Vehicles with Adjustable Speed Limiting equipped come with the max speed set at 25 mph (40 km/h) by default.

### WARNING

Speeds of 30 mph (48 km/h) and above require the use of a DOT-approved helmet. See page 11 for more information.

6. To change the max speed:
  - a. Press the MODE button on the MAX SPEED screen.
  - b. Use the up and down buttons to toggle between the different settings: 15 mph (24 km/h), 20 mph (32 km/h), 25 mph (40 km/h), 30 mph (48 km/h), 35 mph (56 km/h), or OFF. When MAX SPEED is set to OFF, the vehicle's max speed is 40 mph (64 km/h).
  - c. When your preferred setting is displayed on the screen, press the MODE button to select it. This will change the max speed to your selected value and return you to the Options Menu.
  - d. The max speed will remain at the selected value even if the vehicle is turned off and back on again. It does not need to be reset every time the vehicle is restarted.



## FEATURES AND CONTROLS

---

7. To change the PIN:
  - a. Press the MODE button on the CHANGE PIN screen.
  - b. ENTER NEW PIN will scroll across the screen. Enter the new 4-digit PIN by using the up and down buttons to change the digits and the MODE button to select each digit.
  - c. Once you have selected all 4 digits, NEW PIN SET will scroll across the screen. The screen will then go back to its default display.



## DIAGNOSTIC CODE

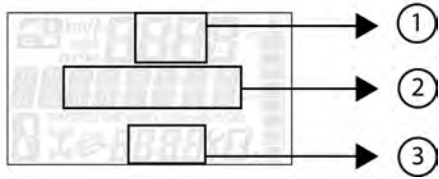

### NOTICE

Diagnostic Code Screen will show available MIL that has come on during that ignition cycle.

1. Press and hold the MODE button to enter the Options Menu.

### NOTICE

"OPTIONS" will display on the screen for 3 seconds before showing first menu item.

2. Select "Diagnostic Codes" from the Options Menu by pressing the MODE button.

Toggle the Up/Down Buttons to cycle through Code(s).

### NOTICE

This option will only be available if a fault code was set or is active during the current ignition key 'on' cycle. Turning off the ignition will clear any save fault codes from the gauge.

Reference the image shown above:

- ① Area A will Display FMI (XX)
  - ② Area B will Display SPN (XXXXXX)
  - ③ Clock Area will Display Count (XXX)
3. To exit the Options Menu the user can select Exit Menu function from Options Menu, can hold Mode Button and exit out of Options Menu, or not press any button for 10 seconds, which will exit out of the Options Menu.

# FEATURES AND CONTROLS

---

## DIAGNOSTIC DISPLAY CODE DEFINITIONS

**Open Load:** There is a break in the wires that lead to the item listed in the chart (injector, fuel pump, etc.), or the item has failed.

**Short-to-Ground:** The wire is shorted to ground between the electronic control unit and the item listed in the chart.

**Shorted Load:** The wires leading to the item listed in the chart are shorted together, or the item has shorted internally.

**Short-to-Battery:** The wire leading from the item listed in the chart to the electronic control unit is shorted to a wire at battery voltage.

DIAGNOSTIC CODES			
COMPONENT	CONDITION	SPN	FMI
Throttle Position Sensor	Voltage Too High	51	3
	Voltage Too Low	51	4
Engine Temperature Sensor	Voltage Too High	110	3
	Voltage Too Low	110	4
	Temperature Too High	110	16
	Engine Overheat Shutdown	110	0
Intake Air Temperature Sensor	Voltage Too High	105	3
	Voltage Too Low	105	4
Manifold Absolute Pressure Sensor	Voltage Too High	102	3
	Voltage Too Low	102	4
	Signal Out of Range	102	2
Crankshaft Position Sensor	Circuit Fault	636	8
	Plausibility Fault	636	2
Vehicle Speed Signal	Speed Too High	84	8
	Plausibility Fault	84	2
Gear Sensor Signal	Voltage Too Low	523	4
	Voltage Too High	523	3
	Signal Fault	523	2

# FEATURES AND CONTROLS

DIAGNOSTIC CODES			
COMPONENT	CONDITION	SPN	FMI
Injector 1 (MAG) (SDI Part Load)	Driver Circuit Open/Grounded	651	5
	Driver Circuit Short to B+	651	3
	Driver Circuit Grounded	651	4
Injector 2 (PTO) (SDI Part Load)	Driver Circuit Open/Grounded	652	5
	Driver Circuit Short to B+	652	3
	Driver Circuit Grounded	652	4
Ignition Coil Primary Driver 1 (MAG)	Driver Circuit Short to B+	1268	3
Ignition Coil Primary Driver 2 (PTO)	Driver Circuit Short to B+	1269	3
Fuel Pump Driver Circuit	Driver Circuit Open/Grounded	1347	5
	Driver Circuit Short to B+	1347	3
	Driver Circuit Grounded	1347	4
Fan Relay Driver Circuit	Driver Circuit Open/Grounded	1071	5
	Driver Circuit Short to B+	1071	3
	Driver Circuit Grounded	1071	4
Idle Air Control	Driver Circuit Open/Grounded	634	5
	Driver Circuit Short to B+	634	3
	Driver Circuit Grounded	634	4
	Position Out of Range	634	7

## FEATURES AND CONTROLS

DIAGNOSTIC CODES			
COMPONENT	CONDITION	SPN	FMI
Starter Enable Circuit	Driver Circuit Open/Grounded	1321	5
	Driver Circuit Short to B+	1321	3
	Driver Circuit Grounded	1321	4
Chassis Relay	Driver Circuit Open/Grounded	520208	5
	Driver Circuit Short to B+	520208	3
	Driver Circuit Grounded	520208	4
All Wheel Drive Control	Driver Circuit Open/Grounded	520207	5
	Driver Circuit Short to B+	520207	3
	Driver Circuit Grounded	520207	4
System Power	Voltage Too High	168	3
	Voltage Too Low	168	4
Throttle Safety Signal	Voltage Too High	520194	3
	Voltage Too Low	520194	4
	Signal Out of Range	520194	2
	Throttle Stuck	520194	7
Active Descent Control System	Driver Circuit Open/Grounded	520203	5
	Driver Circuit Short to B+	520203	3
	Driver Circuit Grounded	520203	4
Idle Speed	Speed Too High	520211	3
	Speed Too Low	520211	4
Right Hand Control	Momentary Driveline Mode Switch Press	520468	31



# FEATURES AND CONTROLS

DIAGNOSTIC CODES			
COMPONENT	CONDITION	SPN	FMI
<b>EPS MODELS ONLY</b>			
Vehicle Speed Sensor	Data Valid But Above Normal Operational Range - Most Severe Level	84	0
	Data Erratic, Intermittent Or Incorrect	84	2
	Abnormal Rate Of Change	84	10
	Received Network Data In Error	84	19
System Power	Data Valid But Above Normal Operational Range - Most Severe Level	168	0
	Voltage Above Normal, Or Shorted To High Source	168	3
	Voltage Below Normal, Or Shorted To Low Source	168	4
Engine Speed	Data Valid But Above Normal Operational Range - Most Severe Level	190	0
	Data Erratic, Intermittent Or Incorrect	190	2
	Received Network Data In Error	190	19
ECU Memory	Bad Intelligent Device Or Component	628	12
	Out Of Calibration	628	13
Calibration	Out Of Calibration	630	13
Steering Over Current Shut Down	Current Above Normal Or Grounded Circuit	520221	6
Steering Excessive Current Error	Current Above Normal Or Grounded Circuit	520222	6

## FEATURES AND CONTROLS

DIAGNOSTIC CODES			
COMPONENT	CONDITION	SPN	FMI
EPS MODELS ONLY			
Steering Torque Partial Failure	Condition Exists	520223	31
Steering Torque Full Failure	Condition Exists	520224	31
EPAS Inverter Temperature	Data Valid But Above Normal Operational Range - Most Severe Level	520225	0
	Data Valid But Above Normal Operating Range - Moderately Severe Level	520225	16
EPAS Communications Receive Data Error	Data Erratic, Intermittent Or Incorrect	520226	2
	Condition Exists	520226	31
Position Encoder Error	Root Cause Not Known	520228	11
	Bad Intelligent Device Or Component	520228	12
	Condition Exists	520228	31
EPAS Software Error	Bad Intelligent Device Or Component	520229	12
	Condition Exists	520229	31
EPAS Power Save Condition	Condition Exists	520231	31
EPS SEPIC Voltage Error	Voltage Above Normal, Or Shorted To High Source	524086	3
	Voltage Below Normal, Or Shorted To Low Source	524086	4

---

## OPERATION

### IMPORTANT INFORMATION

#### WARNING

Failure to operate the vehicle properly can result in a collision, loss of control, accident or rollover, which may result in serious injury or death. Read and understand all safety warnings outlined in the safety section of this owner's manual.

### VEHICLE BREAK-IN PERIOD

The break-in period for your new vehicle is the first 25 hours of operation. No single action on your part is as important as a proper break-in period. Careful treatment of a new engine will result in more efficient performance and longer life for the engine. Perform the following procedures carefully.

#### NOTICE

Excessive heat build-up during the first 3 hours of operation will damage close-fitted engine parts and drive components. Do not operate at full throttle or high speeds during the first 3 hours of use.

### ENGINE AND DRIVETRAIN BREAK-IN

1. Fill the fuel tank with gasoline. Always exercise extreme caution whenever handling gasoline.
2. Check the oil level. Add the recommended oil as needed to maintain the oil level in the safe operating range.
3. Complete the New Operator Driving Procedures.
4. Avoid aggressive use of the brakes.
5. Vary throttle positions. Do not operate at sustained idle.
6. Pull only light loads.
7. Perform regular checks on fluid levels, controls and areas outlined on the daily pre-ride inspection checklist.
8. During the break-in period, change both the oil and the filter at 25 hours or one month.
9. Check fluid levels of transmission and all gearcases after the first 25 hours of operation and every 200 hours thereafter.

## OPERATION

---

### **BRAKE SYSTEM BREAK-IN**

Apply only moderate braking force for the first 50 stops. Aggressive or overly forceful braking when the brake system is new could damage brake pads and rotors.

### **PVT BREAK-IN (CLUTCHES/BELT)**

Always break in the clutches and drive belt of new vehicles, as well as after a belt replacement.

A proper break-in of the clutches and drive belt will ensure a longer life and better performance. Break in the clutches and belt by operating at slower speeds during the break-in period as recommended. Pull only light loads. Avoid aggressive acceleration and high speed operation during the break-in period.

If a belt fails, always clean any debris from the PVT intake and outlet duct and from the clutch and engine compartments when replacing the belt.

### **SAFE OPERATION PRACTICES**

1. Do not allow anyone under 16 years of age or without a valid driver's license to operate this vehicle.
2. Engine exhaust fumes are poisonous. Never start the engine or let it run in an enclosed area.
3. Never operate with accessories not approved by POLARIS for use on this vehicle.
4. Use caution and drive at reduced speeds in conditions of reduced visibility such as fog, rain and darkness. Clean headlights frequently and replace burned out headlamps promptly.
5. Always operate at a speed that's appropriate for the terrain, the visibility and operating conditions and your skills and experience. Never operate at excessive speeds. Never attempt wheelies, jumps, or other stunts. Keep both hands on the steering wheel or handlebars during operation.
6. Never consume alcohol or drugs before or while operating this vehicle.
7. Always use the size and type of tires specified for your vehicle. Always maintain proper tire pressure.
8. Never operate a damaged vehicle. After any rollover or accident, have a qualified service dealer inspect the entire machine for possible damage.
9. Never operate the vehicle on a frozen body of water unless you have first verified that the ice is sufficiently thick to support the weight and moving force of the vehicle, you and your cargo, together with any other vehicles in your party.

10. Do not touch hot exhaust system components. Always keep combustible materials away from the exhaust system.
11. Always remove the ignition key when the vehicle is not in use to prevent unauthorized use.

## PRE-RIDE INSPECTION

### WARNING

Failure to inspect and verify that the vehicle is in safe operating condition before operating increases the risk of an accident. Always inspect the vehicle before each use to make sure it's in safe operating condition.

ITEM	REMARKS	PAGE
Air Filter	Inspect air filter, ensure it is properly installed; ensure air box cover is secured and fastened. Note: Air filter removal is not needed for visual inspection.	page 126
Steering System	Check for tightness/freeplay in the steering wheel when turned lock to lock	page 131
Front / Rear Suspension	Visually inspect for damages to the control arms / trailing arms / bushings; check for leaking shocks	-
Tires	Check for proper air pressure in all tires; visually inspect for damage; verify there is adequate tread depth	page 134
Wheels / Lug Nuts	Ensure rim is not cracked or bent; verify proper lug torque	page 134
Headlights / Taillights	Ensure all lights are operational; adjust headlight aim, as needed	page 136
Brake System	Check brake fluid level is between MIN and MAX; ensure brake pedal is not soft when pushed; inspect for leaks	page 130
Frame / Body Fasteners	Visually inspect for loose body / frame fasteners	-
Engine Oil Level	Verify oil level is in the SAFE range on the dipstick	page 105
Throttle	Inspect for proper operation and smooth travel	page 38
Seat Belts	Check length of belt for damage, check latches for proper operation	page 41

## OPERATION

ITEM	REMARKS	PAGE
Coolant Level	Verify coolant level is filled to the FULL COLD mark on coolant reservoir (if engine is cold); inspect hose and radiator for leaks	page 115
Chassis / Engine Bay / Exhaust	Remove grass, leaves, foreign matter, and other flammable material or debris, especially near the exhaust system.	-

## STARTING THE ENGINE

1. Position the vehicle on a level surface outdoors or in a well ventilated area.
2. Sit in the driver's seat and fasten the seat belt.
3. Place the transmission in PARK.
4. Apply the brakes. Do not press the throttle pedal while starting the engine.
5. Turn the ignition key past the ON/RUN position to START. Engage the starter for a maximum of five seconds. Release the key when the engine starts.
6. If the engine does not start within five seconds, return the ignition switch to the OFF position and wait five seconds. Repeat steps 5 and 6 until the engine starts.
7. Vary the engine RPM slightly with the throttle to aid in warm up until the engine idles smoothly.

### NOTICE

Operating the vehicle immediately after starting could cause engine damage. Allow the engine to warm up for several minutes before operating the vehicle.

## STOPPING THE ENGINE

For maximum engine life, allow the engine to idle, without load, for 5 minutes. This will allow the engine components that operate at high temperatures, such as the exhaust system, to cool slightly before the engine is shut down.

1. Release the throttle pedal completely and brake to a complete stop.
2. Place the transmission in PARK.
3. Slowly release the brake pedal and make sure the transmission is in PARK before exiting the vehicle.
4. Turn the engine off and remove the key to prevent unauthorized use.

### WARNING

A rolling vehicle can cause serious injury. Always place the transmission in PARK when stopping the engine.

## COLD WEATHER OPERATION

If the vehicle is used year-round, check the oil level frequently. A rising oil level could indicate the accumulation of contaminants such as water or excess fuel in the bottom of the crankcase. Water in the bottom of the crankcase can lead to engine damage and must be drained. Water accumulation increases as outside temperature decreases.

## OPERATION

---

### **BRAKING**

1. Release the throttle pedal completely.

**TIP**

When the throttle pedal is released completely and the engine speed drops near an idle, the vehicle has no engine braking.

2. Press on the brake pedal evenly and firmly.

**TIP**

If the throttle pedal and brake pedal are applied simultaneously, engine power may be limited.

3. Practice starting and stopping (using the brakes) until you're familiar with the controls.



## ALL WHEEL DRIVE/REAR DIFFERENTIAL SYSTEM

Your model is equipped with a lockable differential, you can choose to operate with an open differential or a closed differential.

### ENGAGING AWD

#### NOTICE

Switching to AWD while the rear wheels are spinning may cause severe drive shaft and clutch damage. Always switch to AWD while the rear wheels have traction or are at rest.

- ① All-Wheel Drive (AWD)
- ② Differential Lock
- ③ Differential Unlock

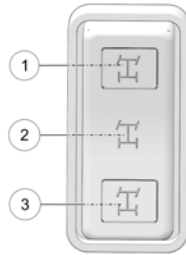

Press the top of the switch to engage All Wheel Drive (AWD). The 4X4 indicator illuminates in the rider information center to indicate that the vehicle is in AWD. When the AWD switch is on, the front gearcase will automatically engage any time the rear wheels lose traction. When the rear wheels regain traction, the front gearcase will automatically disengage. There is no limit to the length of time the vehicle may remain in AWD. Initially, the vehicle's electronic system will not enable the AWD until the engine RPM is below 3100. Once enabled, the AWD remains enabled until the AWD switch is turned off. If the switch is turned off while the front gearcase is moving, it will not disengage until the rear wheels regain traction.

Engage the AWD before getting into conditions where front wheel drive may be needed. If the rear wheels are spinning, release the throttle before switching to AWD.

## OPERATION

---

### DISENGAGING AWD

Move the AWD switch to the center or bottom position to disengage AWD. If the switch is turned off while the front hubs are driving, they will not release until the rear wheels regain traction.

In some situations, the front gearcase may remain locked after turning the AWD switch off. If this occurs, you may notice increased steering effort and some vehicle speed restriction. Perform the following procedure to unlock the front gearcase.

NOTE
All-wheel drive vehicles without an AWD switch may also get their front gearcases locked. The following procedure can be used to unlock the front gearcase on those vehicles as well.

To disengage AWD, do the following:

1. Stop the vehicle.
2. Operate in reverse for at least 10 ft (3 m).
3. Stop completely.
4. Shift into low gear and drive forward.
5. If the front gearcase remains locked after following these instructions, see your dealer or other qualified service person for service.

### LOCKING THE DIFFERENTIAL

Move the rocker switch to the center position to lock the differential and operate in two wheel drive (2WD). Locking the differential in slippery or low traction conditions helps improve traction. When the rear differential is locked, both rear wheels rotate at the same speed.

## UNLOCKING THE DIFFERENTIAL (TURF MODE)

When operating in TURF mode, the inside rear wheel will rotate independently from the outside wheel during turns. Operate in TURF mode only as needed to protect smooth, level surfaces from tire damage. DO NOT operate in TURF mode when climbing or descending hills, when sidehilling, or when operating on uneven, loose, or slippery terrain such as sand, gravel, ice, snow, obstacles, and water crossings. Always operate in AWD on these types of terrain.

### WARNING

Operating in TURF mode when on sloped, uneven, or loose terrain could cause loss of control and result in serious injury or death. One rear wheel may slip and lose traction or may lift up and grab when it touches the ground again.

Press the bottom of the switch to unlock the differential and allow the rear drive wheels to operate independently (1WD). When the rear differential is unlocked, the rear wheels can rotate at different speeds. Unlock the differential to make maneuvering easier and minimize damage to turf.

### NOTICE

Damage to the differential can occur if it is engaged while the vehicle is traveling at high speeds or while the rear wheels are spinning. Slow the vehicle to nearly stopped before engaging the differential.

### WARNING

Never operate in TURF mode while operating on a hill or other irregular terrain. Always move the AWD switch to AWD before ascending or descending a hill.

## OPERATION

---

### DRIVING PROCEDURES

1. All riders should wear substantial footwear, long pants and a close-fitting shirt. A hard hat or helmet and approved eye protection are recommended when appropriate for working or riding conditions.
2. Perform the pre-ride inspection.
3. Sit in the driver's seat and fasten the seat belt.
4. Place the transmission in PARK.
5. Start the engine.
6. Apply the service brakes and shift the transmission into gear.
7. Check your surroundings and determine your path of travel.
8. Keeping both hands on the steering wheel, slowly release the brakes and slowly depress the throttle with your right foot to begin driving.
9. Drive slowly. Practice maneuvering and using the throttle and brakes on level surfaces.
10. Do not carry a passenger until you have at least two hours of driving experience with this vehicle.

### DRIVING WITH A PASSENGER

1. Perform the pre-ride inspection.
2. Make sure all passengers are at least 12 years of age and tall enough to comfortably and safely sit in a passenger seat with the seat belt secured, put both feet on the floor and grasp the hand hold.
3. All riders should wear substantial footwear, long pants and a close-fitting shirt. A hard hat or helmet and approved eye protection are recommended when appropriate for working or riding conditions.
4. Do not carry more than the recommended number of passengers for your vehicle.
5. Allow a passenger to ride only in a passenger seat.
6. Slow down. Always travel at a speed appropriate for your skills, your passengers' skills, and operating conditions. Avoid unexpected or aggressive maneuvers that could cause discomfort or injury to a passenger.
7. Vehicle handling may change with a passenger and/or cargo on board. Allow more time and distance for braking.
8. Always follow all operating guidelines as outlined on safety labels and in this manual.

## DRIVING ON SLIPPERY SURFACES

### ⚠ WARNING

Skidding or sliding can cause loss of control or rollover (if tires regain traction unexpectedly). When operating on slippery surfaces such as ice or loose gravel, reduce speed and use extra caution to reduce the chance of skidding or sliding out of control. Do not operate on excessively slippery surfaces.

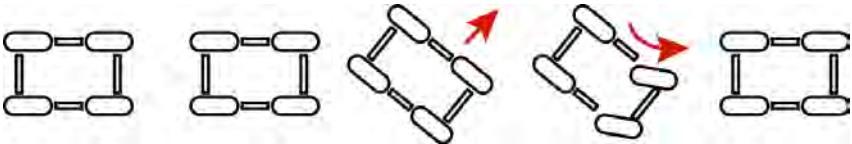

When driving on slippery surfaces such as wet trails, loose gravel, or ice, be alert for the possibility of skidding and sliding. Follow these precautions when encountering slippery conditions:

1. Do not operate on excessively rough, slippery or loose terrain.
2. Slow down before entering slippery areas.
3. Maintain a high level of alertness, reading the trail and avoiding quick, sharp turns, which can cause skids.
4. Correct a skid by turning the steering wheel in the direction of the skid. *Never apply the brakes during a skid.*

## DRIVING UPHILL

Whenever traveling uphill, follow these precautions:

1. Avoid excessively steep hills.
2. Always travel straight uphill.
3. Keep both feet on the floor.
4. Always check the terrain carefully before ascending any hill. Never climb hills with excessively slippery or loose surfaces.
5. Proceed at a steady rate of speed and throttle opening. Never open the throttle suddenly.
6. Never go over the crest of a hill at high speed. An obstacle, a sharp drop, or another vehicle or person could be on the other side of the hill.

## OPERATION

---

### **DRIVING ON A SIDEHILL (SIDEHILLING)**

Driving on a sidehill is not recommended. Improper procedure could cause loss of control or rollover. Avoid crossing the side of any hill unless absolutely necessary.

If crossing a sidehill is unavoidable, follow these precautions:

1. Slow down.
2. Exercise extreme caution.
3. Avoid crossing the side of a steep hill.

### **DRIVING DOWNHILL**

When driving downhill, follow these precautions:

1. Avoid excessively steep hills.
2. Always descend a hill with the direction selector switch on forward. Never descend a hill with the switch on neutral.
3. Drive straight downhill. Avoid descending a hill at an angle, which would cause the vehicle to lean sharply to one side. Travel straight downhill when possible.
4. Slow down.
5. Apply the brakes slightly to aid in slowing.

## DRIVING THROUGH WATER

Your vehicle can operate through water up to a maximum recommended depth equal to the floorboards.

### NOTICE

Immersion can result in major damage if the vehicle isn't serviced correctly and promptly. After immersion, always take the vehicle to your dealer service. Do not start the engine! If it's impossible to bring the vehicle to your dealer before starting the engine, perform the service outlined in the Vehicle Immersion section, and take the vehicle to your dealer at the first opportunity.

Follow these procedures when operating through water:

1. Determine water depths and current before entering water.
2. Choose a crossing where both banks have gradual inclines.
3. Proceed slowly, avoiding rocks and obstacles.
4. Avoid operating through deep or fast-flowing water.

### WARNING

The large tires on your vehicle may cause the vehicle to float in deep or fast-flowing water, which could result in loss of control and lead to serious injury or death. Never cross deep or fast-flowing water with your vehicle

5. After leaving water, always dry the brakes by applying light pressure to the pedal repeatedly until braking action is normal.

### NOTE

After running your vehicle in water, it's critical that you perform the services outlined in the Periodic Maintenance Chart. Give special attention to engine oil, transmission oil, front and rear gearcases (if equipped), and all grease fittings.

## OPERATION

---

### DRIVING IN REVERSE

#### NOTICE

Shifting into reverse automatically activates the reverse alert beeper.

Follow these precautions when operating in reverse:

1. Always check for obstacles or people behind the vehicle. Always inspect left and right fields of vision before backing.
2. Always avoid backing downhill.
3. Back slowly.
4. Apply the brakes lightly for stopping.
5. Avoid turning at sharp angles.
6. Never open the throttle suddenly.

### DRIVING OVER OBSTACLES

Follow these precautions when operating over obstacles:

1. Always check for obstacles before operating in a new area.
2. Look ahead and learn to read the terrain. Be constantly alert for hazards such as logs, rocks and low hanging branches.
3. Travel slowly and use extra caution when operating on unfamiliar terrain. Not all obstacles are immediately visible.
4. Avoid operating over large obstacles such as large rocks and fallen trees. If unavoidable, use extreme caution and operate slowly.
5. Always have all passengers dismount and move away from the vehicle before operating over an obstacle that could cause a rollover.



## **PARKING THE VEHICLE**

To park the vehicle, do the following:

1. Apply the brakes. Stop the vehicle on a level surface.
2. When parking inside a garage or other structure, be sure that the structure is well ventilated and that the vehicle is not close to any source of flame or sparks, including any appliance with pilot lights.
3. Place the transmission in PARK.
4. Turn the engine off.
5. Slowly release the brake pedal and make sure the transmission is in PARK before exiting the vehicle.
6. Remove the ignition switch key to prevent unauthorized use.

## **PARKING ON AN INCLINE**

Avoid parking on an incline if possible. If it's unavoidable, follow these precautions:

1. Apply the brakes.
2. Place the transmission in PARK.
3. Turn the engine off.
4. Slowly release the brake pedal and make sure the transmission is in PARK before exiting the vehicle.
5. Block the rear wheels on the downhill side.

### HAULING CARGO

#### WARNING

Hauling cargo improperly can alter vehicle handling and may cause loss of control or brake instability, which can result in serious injury or death. Always follow these precautions when hauling cargo:

Never exceed the maximum weight capacity of the vehicle. When determining the weight you are adding to the vehicle, include the weight of the operator, passengers, non-factory installed accessories, loads in the rack or box and the load on the trailer tongue. The combined weight of these items must not exceed the maximum weight capacity.

#### **REDUCE SPEED AND ALLOW GREATER DISTANCES FOR BRAKING WHEN HAULING CARGO.**

Always load the cargo box with the load as far forward and as low as possible. When operating over rough or hilly terrain, reduce speed and cargo to maintain stable driving conditions.

Always operate the vehicle with extreme care when hauling or towing loads. Slow down and drive in the lowest gear available. Always use LOW gear when towing or hauling heavy loads.

**SECURE ALL LOADS BEFORE OPERATING.** Unsecured loads can create unstable operating conditions, which could result in loss of control of the vehicle.

**OPERATE ONLY WITH STABLE AND SAFELY ARRANGED LOADS.** When handling off-centered loads that cannot be centered, securely fasten the load and operate with extra caution. Always attach the tow load to the hitch point designated for your vehicle.

**HEAVY LOADS CAN CAUSE BRAKING AND CONTROL PROBLEMS.** Use extreme caution when applying brakes with a loaded vehicle. Avoid terrain or situations that may require backing downhill.

**USE EXTREME CAUTION** when operating with loads that extend over the rack sides. Stability and maneuverability may be adversely affected, causing a rollover.

**DO NOT TRAVEL FASTER THAN THE RECOMMENDED SPEEDS.** Vehicle should never exceed 10 mph (16 km/h) while towing a load on a level grass surface. Vehicle speed should never exceed 5 mph (8 km/h) when towing loads in rough terrain, while cornering, or while ascending or descending a hill.

### LOAD CAPACITY

Your vehicle has been designed to carry or tow specific capacities. Always read and understand the load distribution warnings listed on the warning labels. The total load (operator, passengers, non-factory installed accessories, cargo and weight on hitch) must not exceed the maximum weight capacity of the vehicle.

**⚠ WARNING**

Driving with passengers in the cargo box can result in serious injury or death. Never allow passengers to ride in the cargo box. Passengers must always ride in the cab with seat belts fastened securely.

**TOWING LOADS****⚠ WARNING**

Towing improperly can alter vehicle handling and may cause loss of control or brake instability.

Always follow these precautions when towing:

1. Never load more than 250 lb (113.4 kg) tongue weight on the towing bracket.
2. When towing a disabled vehicle, place the disabled vehicle's transmission in neutral. Do not operate the vehicle faster than 10 mph (16 km/h) when towing.
3. Towing a trailer increases braking distance. Do not operate the vehicle faster than 10 mph (16 km/h) when towing.
4. Do not tow more than the recommended weight for the vehicle.
5. Attach a trailer to the trailer hitch bracket only. Do not attach a trailer to any other location, which could result in loss of control of the vehicle.
6. The total load (operator, accessories, cargo and weight on hitch) must not exceed the maximum weight capacity of the vehicle.

MODEL	TOTAL TOWED LOAD WEIGHT (LEVEL GROUND)	TOTAL TOWED LOAD WEIGHT (15° GRADE)	TOTAL HITCH VERTICAL WEIGHT	MAXIMUM TOWING SPEED
Polaris® PRO XD™	2500 lb (1134 kg)	850 lb (386 kg)	250 lb (113.4 kg)	10 mph (16 km/h)

### DUMPING THE CARGO BOX

To dump the cargo box, do the following:

1. Select a level site to dump the cargo box. Do not attempt to dump or unload the vehicle while parked on an incline.
2. Apply the brakes. Place the transmission in PARK.
3. Ensure that the cargo is positioned evenly or toward the front of the cargo box.
4. Release the tailgate by pulling up on the tailgate latch.

 **WARNING**

If the weight distribution on the box is located toward the rear of the box when the release lever is pulled forward, the box may dump unexpectedly and cause serious injury to the operator or bystanders. Never operate the Release Lever dump lever without ensuring that the load is positioned evenly or at the front of the box.

5. Stand clear and pull up on the cargo box release lever ①. Lift the front of the cargo box to dump the cargo.

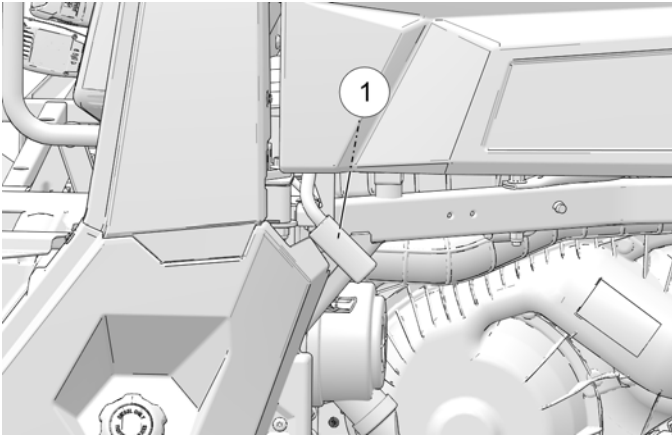

6. Lower the cargo box and push down securely to latch.

**⚠ WARNING**

Operating the vehicle while the cargo box is raised could result in serious injury. The box could close unexpectedly and cause injury to the driver or passenger. The rear tires could also catch the rear of a raised box, damaging the vehicle and creating hazardous driving conditions. Never operate this vehicle with the cargo box in the raised position.



---

## WINCH GUIDE

### WINCH SAFETY

These safety warnings and instructions apply if your vehicle came equipped with a winch or if you choose to add an accessory winch to your vehicle.

 **WARNING**

Improper winch use can result in **SEVERE INJURY** or **DEATH**. Always follow all winch instructions and warnings in this manual.

Your winch may have a cable made of either wire rope or specially designed synthetic rope. The term “winch cable” will be used for either unless noted otherwise.

### WINCH SAFETY PRECAUTIONS

1. Read all sections of this manual.
2. Never use alcohol or drugs before or while operating the winch.
3. Never allow children under 16 years of age to operate the winch.
4. Always wear eye protection and heavy gloves when operating the winch.
5. Always keep body, hair, clothing and jewelry clear of the winch cable, fairlead and hook when operating winch.
6. Never attempt to “jerk” a load attached to the winch with a moving vehicle. See the *Shock Loading* section on page 93.
7. Always keep the area around the vehicle, winch, winch cable, and load clear of people (especially children) and distractions while operating the winch.
8. Always turn the vehicle ignition power OFF when it and the winch are not being used.
9. Always be sure that at least five (5) full turns of winch cable are wrapped around the winch drum at all times. The friction provided by this wrapped cable allows the drum to pull on the winch cable and move the load.
10. Always apply your vehicle’s park brake and/or park mechanism to hold the vehicle in place during winching. Use wheel chocks if needed.
11. Always align the vehicle and winch with the load directly in front of the vehicle as much as possible. Avoid winching with the winch cable at an angle to the winching vehicle’s centerline whenever possible.

## WINCH GUIDE

---

12. If winching at an angle is unavoidable, follow these precautions:
  - a. Look at the winch drum occasionally. Never let the winch cable “stack” or accumulate at one end of the winch drum. Too much winch cable at one end of the winch drum can damage the winch and the winch cable.
  - b. If stacking occurs, stop winching. Follow step 15 of Winch Operation to feed and rewind the cable evenly before continuing the winch operation.
13. Never winch up or down at sharp angles. This can destabilize the winching vehicle and possibly cause it to move without warning.
14. Never attempt to winch loads that weigh more than the winch’s rated capacity.
15. The winch motor may become hot during winch use. If you winch for more than 45 seconds, or if the winch stalls during operation, stop winching and permit the winch to cool down for 10 minutes before using it again.
16. Never touch, push, pull or straddle the winch cable while winching a load.
17. Never let the winch cable run through your hands, even if wearing heavy gloves.
18. Never release the clutch on the winch when the winch cable is under load.
19. Never use the winch for lifting or transporting people.
20. Never use the winch to hoist or suspend a vertical load.
21. Always inspect your winch and winch cable before each use.
22. Never winch the hook fully into the winch. This can cause damage to winch components.
23. Unplug the remote control from the vehicle when the winch is not in use to prevent inadvertent activation and use by unauthorized persons.
24. Never grease or oil the winch cable. This will cause the winch cable to collect debris that will shorten the life of the cable.





## WINCH OPERATION

Read the Winch Safety Precautions in the preceding pages before using your winch.

### TIP

Consider practicing the operation and use of your winch before you actually need to use it in the field.

### ⚠ WARNING

Improper winch use can result in **SEVERE INJURY** or **DEATH**. Always follow all winch instructions and warnings in this manual.

Each winching situation is unique.

- Take your time to think through the winching you are about to do.
- Proceed slowly and deliberately.
- Never hurry or rush during winching.
- Always pay attention to your surroundings.
- You may need to change your winching strategy if it is not working.
- Always remember that your winch is very powerful.
- There are simply some situations that you and your winch will not be able to deal with. Do not be afraid to ask others to help when this happens.

1. Always inspect the vehicle, winch, winch cable and winch controls for any signs of damage or parts in need of repair or replacement before each use. *Pay particular attention to the first 3 feet (1 meter) of winch cable if the winch is being used (or has been used) for lifting an accessory plow assembly.* Promptly replace any worn or damaged cable.
2. Never operate a winch or a vehicle in need of repair or service.
3. Always apply your vehicle's park brake and/ or park mechanism to hold the vehicle in place during winching. Use wheel chocks if needed.
4. Always use the hook strap when handling the hook.



## WINCH GUIDE

### WARNING

Never put your fingers into the hook. This could lead to SEVERE INJURY.

- Attach the hook itself onto the load or use a tow strap or chain to secure the load to the winch cable.



### TIP

A “tow strap” is NOT intended to stretch. A “recovery strap” is designed to stretch.

### WARNING

Never use a recovery strap when winching due to the excessive energy that can be released if the winch cable breaks. This can result in SEVERE INJURY or DEATH. See the *Shock Loading* section on page 93.

- Never hook the winch cable back onto itself. This will damage the winch cable and may result in winch cable failure.

### WARNING

Replace the winch cable at the first sign of damage to prevent SEVERE INJURY or DEATH in the event of failure. For your safety, always replace POLARIS winch parts (including the cable) with genuine POLARIS replacement parts available at your authorized POLARIS dealer, or other qualified dealer.

- If possible, keep the winch cable aligned with the centerline of the winching vehicle. This will help the spooling of the winch cable and reduce the load on the fairlead.
- If freeing a stuck vehicle by attaching to a tree, use an item such as a tow strap to avoid damaging the tree during winch operation. Sharp cables and chains can damage and even kill trees. Please remember to Tread Lightly<sup>SM</sup> (treadlightly.org).
- Before operating the winch, be sure that the safety latch on the winch cable hook is fully seated when the load is attached.
- Never operate your winch with a damaged hook or latch. Always replace damaged parts before using the winch.

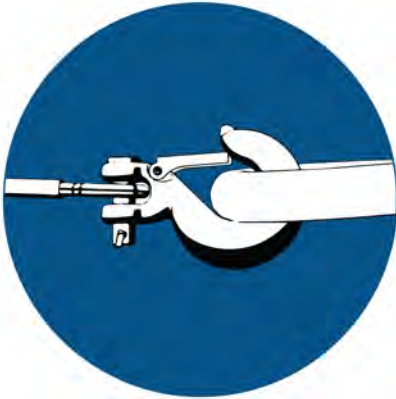

5. Never remove the hook strap from the hook.
6. Release the winch clutch and pull out the winch cable.
7. Pulling out as much cable as possible maximizes the winch's pulling capacity. Always be sure that at least five (5) full turns of winch cable are wrapped around the winch drum at all times. The friction provided by this wrapped cable allows the drum to pull on the winch cable and move the load.
8. Read and adhere to the following information for winch damping to ensure safe winch use.
  - a. In order to absorb energy that could be released by a winch cable failure, always place a "damper" on the winch cable. A damper can be heavy jacket, tarp, or other soft, dense object. A damper can absorb much of the energy released if a winch cable breaks when winching. Even a tree limb can help as a damper if no other items are available to you.
  - b. Lay the damper on top of the mid-point of the winch cable length that is spooled out.

## WINCH GUIDE

---

- c. On a long pull, it may be necessary to stop winching so that the damper can be repositioned to the new mid-point of the winch cable. Always release the tension on the winch cable before repositioning the damper.
  - d. Avoid being directly in line with the winch cable whenever possible. Also, never permit others to stand near or in line with the winch cable during winch operation.
9. Never hook the winch cable back onto itself. This will damage the winch cable and may result in winch cable failure.
10. Never use straps, chains or other rigging items that are damaged or worn.
11. The ONLY time a winch-equipped vehicle should be moving when using the winch is when that vehicle itself is stuck. The winch equipped vehicle should NEVER be in motion to “shock” load the winch cable in an attempt to move a second stuck vehicle. See the Shock Loading section on page 93. For your safety, always follow these guidelines when winching a vehicle free:
- a. Release the winch clutch and spool out the necessary length of winch cable.
  - b. Align the winch cable as close as possible to the winching vehicle's centerline.
  - c. Attach the winch cable hook to the anchor point or the stuck vehicle's frame following instructions in this manual.
  - d. Re-engage the clutch on the winch.
  - e. Slowly winch in the slack in the winch cable.
  - f. Select the proper vehicle gear to propel the stuck vehicle in the direction of winching.
  - g. Shift to the lowest gear available on the stuck vehicle.
  - h. Slowly and carefully apply vehicle throttle and winch together to free the vehicle.
  - i. Stop winching as soon as the stuck vehicle is able to propel itself without the help of the winch.
  - j. Detach the winch cable hook.
  - k. Rewind the winch cable evenly back onto the winch drum following the instructions in this manual.
12. Never attempt to winch another stuck vehicle by attaching the winch cable to a suspension component, brush guard, bumper or cargo rack. Vehicle damage may result. Instead, attach the winch to a strong portion of the vehicle frame or hitch.

13. Extensive winching will run down the battery on the winching vehicle. Let the winching vehicle's engine run while operating the winch to prevent the battery from running low if winching for long periods.
14. The winch motor may become hot during winch use. If you winch for more than 45 seconds, or if the winch stalls during operation, stop winching and permit the winch to cool down for 10 minutes before using it again.
15. After winching is complete, especially if winching at an angle, it may be necessary to re-distribute the winch cable across the winch drum. You will need an assistant to perform this task.
  - a. Release the clutch on the winch.
  - b. Feed out the winch cable that is unevenly bunched up in one area.
  - c. Re-engage the winch clutch.
  - d. Have an assistant pull the winch cable tightly with about 100 lbs. (45 kg) of tension using the hook strap.
  - e. Slowly winch the cable in while your assistant moves the end of the winch cable back and forth horizontally to evenly distribute the winch cable on the drum.
  - f. Doing this reduces the chances of the winch cable "wedging" itself between lower layers of winch cable.

### WINCH CABLE CARE

#### WARNING

Use of worn or damaged cable could lead to sudden failure and SEVERE INJURY.

For your safety, always replace POLARIS winch parts (including the cable) with genuine POLARIS replacement parts available at your authorized POLARIS dealer, or other qualified person.

1. Always inspect your winch before each use. Inspect for worn or loose parts including mounting hardware. Never use the winch if any part needs repair or replacement.
2. Always inspect your winch cable before each use. Inspect for worn or kinked winch cable.

A kinked winch cable made of wire rope is shown at right. Even after being “straightened out,” this cable has already been permanently and severely damaged. Promptly discontinue use of a winch cable in this condition.

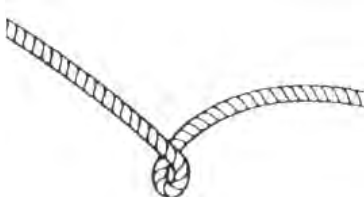

A kinked winch cable made of wire rope that has been “straightened out” is shown at right. Even though it may look usable, the cable has been permanently and severely damaged. It can no longer transmit the load that it could prior to kinking. Promptly discontinue use of a winch cable in this condition.

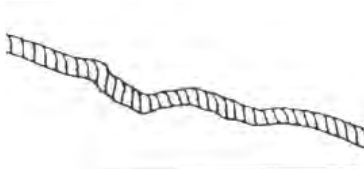

A winch cable made of synthetic rope should be inspected for signs of fraying. Replace the cable if fraying is observed (shown below). Promptly discontinue use of a winch cable in this condition. Also replace the winch cable if there are frayed or melted fibers. Such an area of the synthetic rope will be stiff and appear smooth or glazed. Promptly discontinue use of a winch cable in this condition.



## SHOCK LOADING

### WARNING

Your winch cable is very strong but it is NOT designed for dynamic, or “shock” loading. Shock loading may tension a winch cable beyond its strength and cause the cable to break. The end of a broken winch cable under such high loading can cause SEVERE INJURY or DEATH to you and other bystanders.

*Winch cables are designed to NOT absorb energy. This is true of both wire-ropes and synthetic-rope winch cables.*

1. Never attempt to “jerk” a load with the winch. For example, never take up slack in the winch cable by moving the winching vehicle in an attempt to move an object. This is a dangerous practice. It generates high winch cable loads that may exceed the strength of the cable. Even a slowly moving vehicle can create large shock loads in a winch cable.

### WARNING

SEVERE INJURY or DEATH can result from a broken winch cable.

2. Never quickly turn the winch ON and OFF repeatedly (“jogging”). This puts extra load on the winch, winch cable, and generates excessive heat from the motor. This is a form of shock loading.
3. Never tow a vehicle or other object with your winch. Towing an object with a winch produces shock loading of the cable even when towing at slow speeds. Towing from a winch also positions the towing force high on the vehicle. This can cause instability of the vehicle and possibly lead to an accident.
4. Never use recovery straps with your winch. Recovery straps are designed to stretch and can store energy. This stored energy in the recovery strap is released if a winch cable fails making the event even more hazardous. Similarly, never use elastic “bungie” cords for winching.
5. Never use the winch to tie down a vehicle to a trailer or other transportation vehicle. This type of use also causes shock loading that can cause damage to the winch, winch cable, or vehicles used.

**Your winch cable is designed and tested to withstand the loads produced by the winch motor when operated from a stationary vehicle. Always remember that the winch and winch cable are NOT designed for shock loading.**

# WINCH MAINTENANCE AND SERVICE SAFETY

 **WARNING**

Improper or lack of winch maintenance and service could lead to **SEVERE INJURY** or **DEATH**. Always follow all winch instructions and warnings in this manual.

1. Always inspect your winch before each use. Inspect for worn or kinked winch cable. Also inspect for worn or loose parts including mounting hardware.
2. Permit your winch motor to cool down prior to servicing your winch.
3. Never work on your winch without first disconnecting the battery connections to prevent accidental activation of the winch.
4. For your safety, always replace POLARIS winch parts (including the cable) with genuine POLARIS replacement parts available at your authorized POLARIS dealer, or other qualified person.
5. Some winch models use wire rope as the winch cable. Other winches use a specially designed synthetic rope as the winch cable.
6. Never replace a synthetic-rope winch cable with a consumer-grade polymer rope such as can be purchased in a hardware store. Although they may look similar, they are **NOT** alike. A polymer rope not designed for winch use will stretch and store excessive energy when winching.

 **WARNING**

Failure of a stretched rope under winching conditions will release all of the stored energy. This will increase the chances of **SEVERE INJURY** or **DEATH**.



# EMISSION CONTROL SYSTEMS

## NOISE EMISSION CONTROL SYSTEM

Do not modify the engine, intake or exhaust components, as doing so may affect compliance with U.S.A. EPA noise control requirements (40 CFR 205) and local noise level requirements.

## OPERATION ON PUBLIC LANDS IN THE U.S.A.

Your vehicle has a spark arrestor that was tested and qualified to be in accordance with the USFS standard 5100-1a. Federal law requires that this spark arrestor be installed and functional when the vehicle is operated on public lands.

Operation of off-road vehicles on public lands in the U.S.A. is regulated by 43 CFR 420. Violations are subject to monetary penalties. Federal regulations can be viewed online at <https://ecfr.federalregister.gov/current/title-43/subtitle-B/chapter-1/part-420>.

## CRANKCASE EMISSION CONTROL SYSTEM

This engine is equipped with a closed crankcase system. Blow-by gases are forced back to the combustion chamber by the intake system. All exhaust gases exit through the exhaust system.

## EXHAUST EMISSION CONTROL SYSTEM

Exhaust emissions are controlled by engine design. An electronic fuel injection (EFI) system controls fuel delivery. The engine and EFI components are set at the factory for optimal performance and are not adjustable.

The emissions label is located on the inside of the lower left frame tube (below driver's foot area).

## ELECTROMAGNETIC INTERFERENCE

This spark ignition system complies with Canadian ICES-002.

This vehicle complies with the EMC requirements of UN ECE Regulation 10.

Non-ionizing Radiation: This vehicle emits some electromagnetic energy. People with active or non-active implantable medical devices (such as heart monitoring or controlling devices) should review the limitations of their device and the applicable electromagnetic standards and directives that apply to this vehicle.



---

# MAINTENANCE

## PERIODIC MAINTENANCE OVERVIEW

Any qualified repair shop or person may maintain, replace or repair the emission control devices or systems on your vehicle. An authorized POLARIS dealer can perform any service that may be necessary for your vehicle. POLARIS also recommends POLARIS parts for emissions-related service, however equivalent parts may be used for such service.

It is a potential violation of the Clean Air Act if a part supplied by an aftermarket parts manufacturer reduces the effectiveness of the vehicle's emission controls. Tampering with emission controls is prohibited by federal law.

Owners are responsible for performing the scheduled maintenance identified in this owner's manual.

Inspection, adjustment and lubrication of important components are explained in the periodic maintenance chart.

Inspect, clean, lubricate, adjust and replace parts as necessary. When inspection reveals the need for replacement parts, genuine POLARIS parts are available from your POLARIS dealer.

Record maintenance and service in the Maintenance Log at the end of the manual.



Service and adjustments are critical. If you're not familiar with safe service and adjustment procedures, have a qualified dealer perform these operations.

Maintenance intervals in the following chart are based upon average riding conditions and an average vehicle speed of approximately 10 mph (16 km/h). Vehicles subjected to severe use must be inspected and serviced more frequently.

### Severe Use Definition

- Frequent immersion in mud, water or sand
- Prolonged low speed, heavy load operation
- Extended idle
- Short trip cold weather operation

Pay special attention to the oil level. A rise in oil level during cold weather can indicate contaminants collecting in the oil sump or crankcase. Change oil immediately if the oil level begins to rise. Monitor the oil level, and if it continues to rise, discontinue use and determine the cause or see your dealer.

# MAINTENANCE

---

## BREAK-IN PERIOD

The break-in period consists of the first 25 hours of operation. Careful treatment of a new engine and drive components will result in more efficient performance and longer life for these components.

- Drive vehicle slowly at first while varying the throttle position. Do not operate at sustained idle.
- Perform regular checks on fluid levels and other areas outlined on the daily pre-ride inspection checklist.
- Change both the engine oil and filter after 25 hours or one month.

## MAINTENANCE INTERVALS

The maintenance interval charts list required maintenance and inspection based on vehicle hours / miles. Each table states a service that corresponds to the hour / mile chart below. Some items or components may need to be serviced more often due to severe use, such as operation in water, extreme temperatures, or under severe loads.

<b>HOUR / MILEAGE</b>	<b>SERVICE</b>
First 25 hours / 200 miles (320 km)	Break-In Service — Perform the 200 Hour Check List (Table 2)
Every 50 hours / 500 miles (800 km) thereafter	See Table 1
Every 100 hours / 1000 miles (1600 km) thereafter	See Table 2
Every 200 hours / 2000 miles (3200 km) thereafter	See Table 3

## SERVICE CODES

**XU - PERFORM THESE PROCEDURES MORE OFTEN FOR VEHICLES SUBJECTED TO SEVERE USE.**

**D - HAVE AN AUTHORIZED POLARIS DEALER OR OTHER QUALIFIED PERSON PERFORM THESE SERVICES.**

**E - EMISSION CONTROL SYSTEM SERVICE (CALIFORNIA).**

## BREAK-IN SERVICE FIRST 25 HOURS / 200 MILES (320 KM)

Perform the 200 Hour Checklist (Table 3) for Break-In Service

### TABLE 1. EVERY 50 HOURS / 500 MILES (800 KM) SERVICE

CODE	ITEM	ACTION
XU / E	Engine Oil & Filter Change	Inspect oil level (Break-in oil and filter change at first 25 hrs)
XU	Brake Pads	Inspect pad wear; contact dealer to replace if worn beyond service limit
E	Fuel System	Turn key on to pressurize fuel pump; check lines and fittings for leaks and abrasion, contact dealer for any repairs
	Battery	Check terminals; clean if necessary
XU	Front Gearcase Lubricant	Inspect / add lubricant if needed
XU	Transmission Lubricant (AGL)	Inspect / add lubricant if needed
XU	Air Filter / Air Box	Inspect; replace filter as needed, or yearly (Item part of Pre-Ride Inspection)
E	Air Intake Ducts / Adapters / Engine Breather	Inspect ducts for proper sealing, and ensure clamps are tight; contact dealer for any repairs

## MAINTENANCE

**TABLE 1.**  
**EVERY 50 HOURS / 500 MILES (800 KM) SERVICE**

<b>CODE</b>	<b>ITEM</b>	<b>ACTION</b>
	Shift Cable / Linkage	Inspect; Contact dealer to adjust as needed,
	Steering	Inspect for loose components and torn boots; contact dealer to replace parts as needed
XU	Rear Stabilizer Bar	Lubricate and inspect bushings
XU	Radiator	Inspect; clean external surfaces
XU	Axles	Inspect boots for damage

**TABLE 2.**  
**EVERY 100 HOURS / 1000 MILES (1600 KM) SERVICE**

CODE	ITEM	ACTION
XU / E	Engine Oil & Filter Change	Change oil and filter.
XU	Brake Pads	Inspect pad wear; contact dealer to replace if worn beyond service limit
E	Fuel System	Turn key on to pressurize fuel pump; check lines and fittings for leaks and abrasion, contact dealer for any repairs
	Battery	Check terminals; clean if necessary
XU	Front Gearcase Lubricant	Inspect / add lubricant if needed
XU	Transmission Lubricant (AGL)	Inspect / add lubricant if needed
XU	Air Filter / Air Box	Inspect; replace filter as needed, or yearly (Item part of Pre-Ride Inspection)
E	Air Intake Ducts / Adapters / Engine Breather	Inspect ducts for proper sealing, and ensure clamps are tight; contact dealer for any repairs
	Shift Cable / Linkage	Inspect; Contact dealer to adjust as needed,
	Steering	Inspect for loose components and torn boots; contact dealer to replace parts as needed
XU	Rear Stabilizer Bar	Lubricate and inspect bushings
XU	Radiator	Inspect; clean external surfaces
XU	Axles	Inspect boots for damage

## MAINTENANCE

**TABLE 3.  
EVERY 200 HOURS / 2000 MILES (3200 KM) SERVICE**

<b>CODE</b>	<b>ITEM</b>	<b>ACTION</b>
XU / E	Engine Oil & Filter Change	Change oil and filter. (Perform a break-in oil/filter change at first 25 hrs)
	Spark Plug	Replace spark plugs
XU / D	Brake Pads / Parking Brake Pads	Inspect pad wear; replace if worn beyond service limit
D / E	Fuel System	Turn key on to pressurize fuel pump; check lines and fittings for leaks and abrasion, check for leaks at fill cap, and fuel pump.
	Battery	Check terminals; clean; test
D / E	Throttle Pedal	Inspect; replace if it sticks
E	Air Intake Ducts / Adapters / Engine Breather	Inspect ducts for proper sealing, and ensure clamps are tight; contact dealer for any repairs
XU	Air Filter / Air Box	Replace filter (Item part of Pre-Ride Inspection)
	Shift Cable / Linkage	Inspect; adjust as needed
D	Steering	Inspect for loose components and torn boots; replace parts as needed
D	Cooling System	Inspect coolant strength; pressure test system Replace coolant every 5 years.
D	Drive Belt	Inspect; replace as needed
XU	Front Gearcase Lubricant	Change lubricant - break in only requires inspection
XU	Transmission Lubricant (AGL)	Change lubricant- break in only requires inspection



**TABLE 3.  
EVERY 200 HOURS / 2000 MILES (3200 KM) SERVICE**

<b>CODE</b>	<b>ITEM</b>	<b>ACTION</b>
D	Ratcheting Cam Chain Tensioner	Check; replace as needed
XU	Radiator	Inspect; clean external surfaces
XU	Cooling Hoses	Inspect for leaks; pressure test system
XU / D	Engine Mounts	Inspect, torque to specification
XU	Engine Oil Lines / Fasteners	Inspect for leaks and loose fittings
D	Engine Valve Clearance	Check clearance; adjust as needed
	Exhaust Silencer / Pipe / Spark Arrester	Inspect, clean out, replace components as needed; Clean out after operating in mud
XU	Wiring	Inspect for wear, routing, security; inspect connectors subjected to water, mud, etc.
D	Clutches (Drive and Driven)	Inspect; clean; replace worn parts
D	Wheel Bearings	Inspect; replace as needed
XU	Tires / Wheels	Inspect tire tread; rotate as needed
XU	Shocks	Visually inspect shock seals, replace as necessary
D	Brake Fluid	Inspect level and quality, Change every 2 years (DOT 4)
D	Front Wheel Alignment	Inspect toe alignment, and adjust if necessary
	Suspension Bushings	Inspect front and rear suspension bushings; replace if necessary
XU	Rear Stabilizer Bar	Lubricate grease zerks and inspect bushings

## MAINTENANCE

**TABLE 3.**  
**EVERY 200 HOURS / 2000 MILES (3200 KM) SERVICE**

CODE	ITEM	ACTION
XU	Prop Shafts	Lubricate grease zerks
XU	Axles	Inspect boots for damage

## LUBRICATION RECOMMENDATIONS

Check and lubricate all components at the intervals outlined in the Periodic Maintenance Chart, or more often under severe use, such as wet or dusty conditions. Items not listed in the chart should be lubricated at the general lubrication interval.

ITEM	LUBE	METHOD
Engine Oil	PS-4 5W-50 4-Cycle Oil	Add to proper level on dipstick. See page 105.
Brake Fluid	DOT 4 Brake Fluid	Maintain level between fill lines. See page 130.
Transmission Oil (Main Gearcase)	AGL Gearcase Lubricant & Transmission Fluid	See page 109.
Demand Drive Fluid (Front Gearcase)	Demand Drive Fluid	See page 110.
Prop Shaft	U-Joint Grease	Locate fittings and grease.

## ENGINE OIL

Always check and change the oil at the intervals outlined in the Periodic Maintenance Chart. Always use the recommended engine oil. Always change the oil filter whenever changing oil.

Pay special attention to the oil level. A rise in oil level during cold weather can indicate contaminants collecting in the oil sump or crankcase. Change oil immediately if the oil level begins to rise. Monitor the oil level, and if it continues to rise, discontinue use and determine the cause. Your dealer can assist.

### WARNING

Vehicle operation with insufficient, deteriorated, or contaminated engine oil will cause accelerated wear and may result in engine seizure, accident and injury. Always perform the maintenance procedures as outlined in the Periodic Maintenance Chart.

## OIL RECOMMENDATIONS

POLARIS recommends the use of POLARIS PS-4 5W-50 4-Cycle Oil or a similar oil. Refer to the Specifications section for capacities.

Oil may need to be changed more frequently if POLARIS PS-4 engine oil is not used. Follow the manufacturer's recommendations for ambient temperature operation. See the Polaris Products section for part numbers.

### NOTICE

Mixing brands or using a non-recommended oil may cause serious engine damage. Always use the recommended oil. Never substitute or mix oil brands.

## OIL CHECK

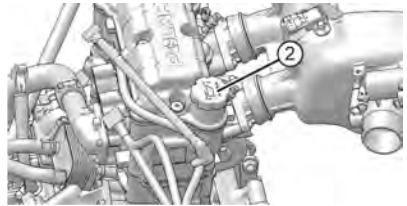
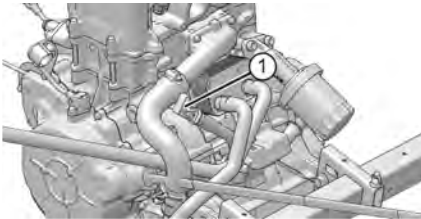

The oil dipstick is located on the engine. Access the dipstick through the right rear wheel well.

To check the oil, do the following:

1. Position vehicle on a level surface and place the transmission in PARK.
2. Stop the engine and allow it to cool down before removing the dipstick.

## MAINTENANCE

---

3. Raise the cargo box. Unlock the dipstick lever ①. Remove the dipstick and wipe it dry with a clean cloth.
4. Reinstall the dipstick and push it into place. Do not lock the dipstick.

### NOTE

Make certain the dipstick is inserted all the way into the dipstick tube to keep the depth of the dipstick consistent.

5. Remove the dipstick and check the oil level.
6. Add the recommended oil as necessary to bring the oil level within the SAFE range on dipstick. Do not overfill (see NOTE below).

### NOTE

A rising oil level between checks during cold weather operation can indicate contaminants such as gas or moisture collecting in the crankcase. If the oil level is over the upper mark, change the oil immediately.

7. With the cargo box raised, add engine oil through the oil fill cap ② located on top of the valve cover, under the cargo box.
8. When finished, reinstall dipstick and lock the lever. Lower the cargo box and secure in position.
9. Check for oil leaks.

## ENGINE OIL AND FILTER REPLACEMENT

Always change engine oil and filter at the intervals outlined in the Periodic Maintenance Chart. Always change the oil filter whenever changing the engine oil.

The engine oil dipstick is located on the right front side of the engine. The engine oil fill cap is located on top of the valve cover. Access the oil dipstick and oil fill cap by tilting the rear cargo box.

The crankcase drain plug is located on the bottom of the crankcase. Access the drain plug through the skid plate access hole located directly under the crankcase.

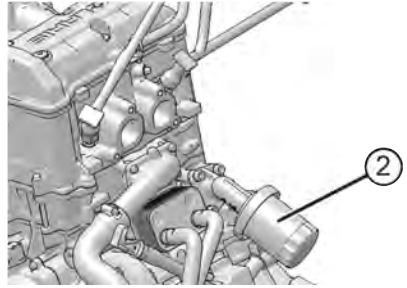
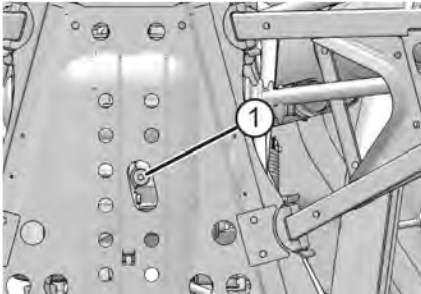

1. Position vehicle on a level surface and place the transmission in PARK.
2. Stop the engine and allow it to cool down.
3. Clean the area around the crankcase drain plug①.

**⚠ CAUTION**

Use caution when performing this procedure. Do not allow hot engine oil to come into contact with skin, as serious burns may result.

4. Place a drain pan under the engine crankcase and remove the drain plug. Allow the oil to drain completely.
5. Remove all cargo from the cargo box.

**⚠ CAUTION**

Always remove all cargo from the cargo box before lifting the box to access the engine.

6. Pull up on the cargo box release lever to tilt the box.
7. Using the Oil Filter Wrench, turn the oil filter ② counter-clockwise to remove it.

## MAINTENANCE

---

- Using a clean dry cloth, clean the filter sealing surface on the engine crankcase.
- Lubricate the O-ring on the new oil filter with a film of fresh engine oil. Check to make sure the O-ring is in good condition. Install it to specification.

### TORQUE

Oil Filter: **Turn by hand until filter O-ring contacts sealing surface, then turn an additional 3/4 turn.**

- Replace the sealing washer on drain plug.

### NOTE

The sealing surface on the drain plug should be clean and free of burrs, nicks or scratches.

- Reinstall the engine crankcase drain plug. Torque drain plug to specification.

### TORQUE

Crankcase Drain Plug: **12 ft-lbs (16 N·m)**

- Remove oil fill cap. Fill engine with recommended engine oil.
- Verify the transmission is still in PARK.
- Start the engine and allow it to idle for 30 seconds.
- Stop the engine and inspect for oil leaks. Wait at least 15 seconds before removing the dipstick.
- Unlock the dipstick lever. Remove the dipstick and wipe it dry with a clean cloth.
- Reinstall the dipstick and push it into place. Do not lock the dipstick.

### NOTE

Make certain the dipstick is inserted all the way into the dipstick tube to keep the depth of the dipstick consistent.

- Remove the dipstick and check the oil level.
- Add the recommended oil as necessary to bring the oil level within the SAFE range on dipstick. Do not overfill.
- When finished, reinstall the oil fill cap, oil dipstick and lock the lever.
- Dispose of used oil and filter properly.

## GEARCASES

### GEARCASE SPECIFICATION CHART

GEARCASE	LUBRICANT	CAPACITY	FILL PLUG TORQUE	DRAIN PLUG/ LEVEL CHECK PLUG TORQUE
Transmission (Main Gearcase)	AGL Gearcase Lubricant & Transmission Fluid	41 fl oz (1200 mL)	10–14 ft-lbs (14–19 N·m)	10–14 ft-lbs (14–19 N·m)
Demand Drive Unit (Front Gearcase)	Demand Drive Fluid	9.3 fl oz (275 mL)	8–10 ft-lbs (11–14 N·m)	11 ft-lbs (15 N·m)

## TRANSMISSION (MAIN GEARCASE)

### TRANSMISSION OIL CHECK

Always check and change the transmission oil at the intervals outlined in the Periodic Maintenance Chart. Maintain the oil level even with the bottom thread of the fill plug hole.

The fill plug is located on the rear of the gearcase. Maintain the fluid level at the bottom of the fill plug hole.

To check the transmission fluid, do the following:

1. Position the vehicle on a level surface.
2. Remove the fill plug ①.
3. Check the fluid level.
4. Add the recommended fluid to the bottom of the fill plug hole. Do not overfill.
5. Reinstall the fill plug. Torque to specification.

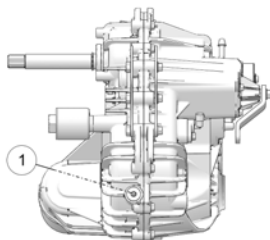

## MAINTENANCE

---

### **TRANSMISSION OIL CHANGE**

The drain plug is located on the bottom of the gearcase. Access the drain plug through the hole in the skid plate.

1. Remove the fill plug ①.
2. Place a drain pan under the drain plug ②.
3. Remove the drain plug. Allow the fluid to drain completely.
4. Clean and reinstall the drain plug. Torque to specification.
5. Add the recommended fluid to the bottom of the fill plug hole. Do not overfill.
6. Reinstall the fill plug. Torque to specification.
7. Check for leaks. Discard used fluid properly.

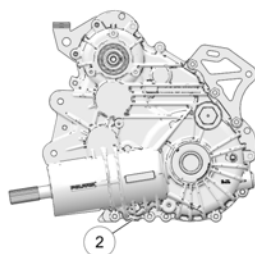

### **DEMAND DRIVE (FRONT GEARCASE) (IF EQUIPPED)**

#### **DEMAND DRIVE OIL CHECK**

Always check and change the demand drive fluid at the intervals outlined in the Periodic Maintenance Chart. Maintain the oil level even with the bottom thread of the fill plug hole. Refer to the Gearcase Specifications Chart for recommended lubricants, capacities and torque specifications.

The front gearcase fill plug ① is located on the right side of the front gearcase.

1. Position the vehicle on a level surface.
2. Remove the fill plug ①. Check the oil level.
3. Add the recommended oil as needed.
4. Reinstall the fill plug. Torque to specification.

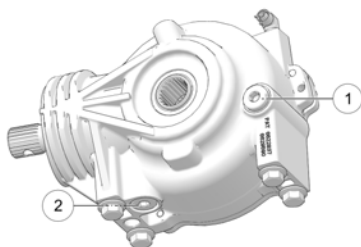



## DEMAND DRIVE OIL CHANGE

1. Support the vehicle securely with a jackstand.
2. Remove the front tire on the passenger's side for ease of access (optional).
3. Remove the fill plug.
4. Place a drain pan under the drain plug ② on the bottom right-hand side.
5. Remove the drain plug. Drain the oil.
6. Clean and reinstall the drain plug. Torque to specification.
7. Add the recommended fluid to the bottom of the fill plug hole. Do not overfill.
8. Reinstall the fill plug. Torque to specification.
9. Check for leaks.
10. Discard used oil properly.

## GREASE LUBRICATION POINTS

There are grease fittings at the rear stabilizer bar bushings and on the front propshaft yokes. Apply grease until all traces of water have been purged out at each of these areas.

ITEM	LUBE REC	METHOD	FREQUENCY
Propshaft Yoke	<b>Premium U-Joint Lubricant</b>	Grease middle ① fitting	Grease fittings every 500 miles (800 km); Grease before long periods of storage, and after thoroughly washing or submerging the vehicle
Rear Stabilizer Bar Bushings	<b>Premium All Season Grease</b>	Grease fittings ②	Grease fittings every 500 miles (800 km); Grease before long periods of storage, and after thoroughly washing or submerging the vehicle

# MAINTENANCE

## BASE

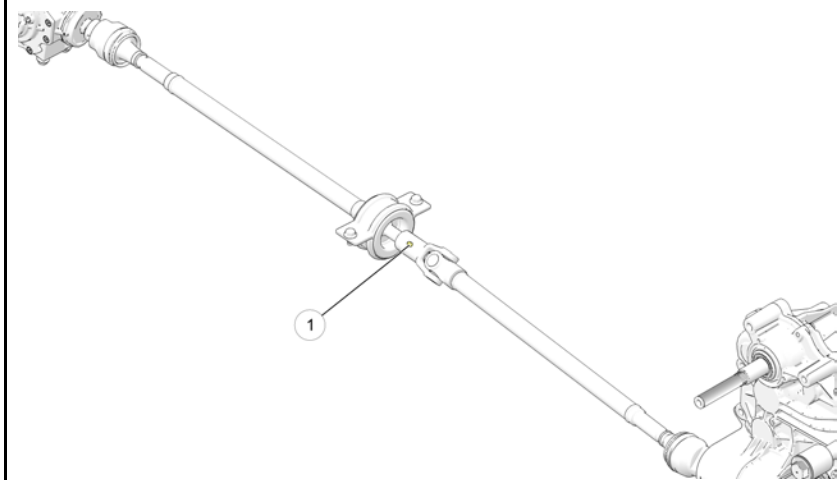

## CREW

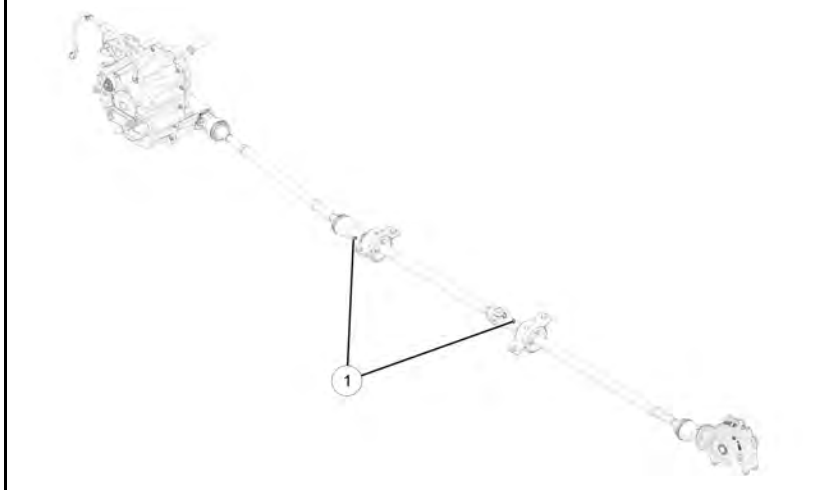

**Rear Stabilizer Bar Bushings, Right and Left Side**

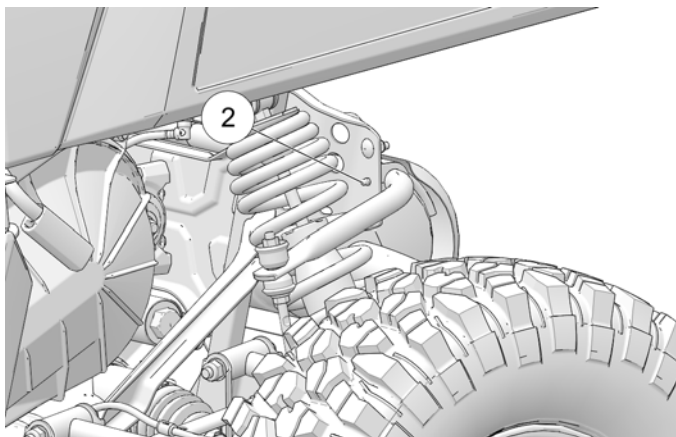

## SPARK PLUGS

### SPARK PLUG RECOMMENDATIONS

Refer to the Specifications section for the recommended spark plug type for your vehicle. Always torque spark plugs to specification.

**NOTICE**

Using non-recommended spark plugs can result in serious engine damage. Always use POLARIS-recommended spark plugs or their equivalent.

### SPARK PLUG GAP/TORQUE

ELECTRODE GAP	NEW OR USED PLUG TORQUE
0.03 in (0.85 mm)	15 ft-lbs (20 N·m)

### SPARK PLUG INSPECTION

Spark plug condition is indicative of engine operation. The spark plug firing end condition should be read after the engine is warmed up and the vehicle is driven at higher speeds. Immediately check the spark plug for correct color.

## MAINTENANCE



A hot exhaust system and engine can cause burns. Wear protective gloves when removing a spark plug for inspection.

To inspect the spark plugs, do the following:

1. Lift the cargo box to access the spark plugs.
2. Remove the spark plug cap. Using a ratchet and socket set, remove the plug by rotating it counter-clockwise.
3. Reverse the procedure for spark plug installation.
4. Torque to specification.

### **NORMAL PLUG**

The normal insulator tip is gray, tan or light brown. There will be few combustion deposits. The electrodes are not burned or eroded. This indicates the proper type and heat range for the engine and the service.

The tip should not be white. A white insulator tip indicates overheating, caused by use of an improper spark plug or incorrect throttle body adjustments.

### **WET FOULED PLUG**

The wet fouled insulator tip is black. A damp oil film covers the firing end. There may be a carbon layer over the entire nose. Generally, the electrodes are not worn. General causes of fouling are excessive oil, use of non-recommended oil or poor fuel quality.

## COOLING SYSTEM

The engine coolant level is controlled or maintained by the recovery system. The recovery system components are the overflow bottle, radiator filler neck, radiator pressure cap and connecting hose.

As coolant operating temperature increases, the expanding (heated) excess coolant is forced out of the radiator, past the pressure cap, and into the overflow bottle. As engine coolant temperature decreases, the contracting (cooled) coolant is drawn back up from the tank, past the pressure cap, and into the radiator.

Some coolant level drop on new vehicles is normal as the system is purging itself of trapped air. Observe coolant levels and maintain as recommended by adding coolant to the overflow bottle.

## ADDING OR CHANGING COOLANT

POLARIS recommends the use of POLARIS Antifreeze 50/50 Premix. This antifreeze is already premixed and ready to use. Do not dilute with water.

To ensure that the coolant maintains its ability to protect the engine, we recommend that the system be completely drained every five (5) years and fresh Antifreeze 50/50 Premix added.

Any time the cooling system has been drained for maintenance or repair, replace the coolant with fresh Antifreeze 50/50 Premix. If the recovery bottle has run dry, the level in the radiator should be inspected. Add coolant as needed.

## RADIATOR AND COOLING FAN

Always check and clean the screen and radiator fins at the intervals outlined in the Periodic Maintenance Chart. Do not obstruct or deflect air flow through the radiator by installing unauthorized accessories in front of the radiator or behind the cooling fan. Interference with the radiator air flow can lead to overheating and consequent engine damage.

### NOTICE

Washing the vehicle with a high-pressure hose could damage the radiator fins and impair the radiator's effectiveness. Using a high-pressure system is not recommended.

## MAINTENANCE

### RADIATOR COOLANT LEVEL

Always check and clean the screen and radiator fins at the intervals outlined in the Periodic Maintenance Chart. Do not obstruct or deflect air flow through the radiator by installing unauthorized accessories in front of the radiator or behind the cooling fan. Interference with the radiator air flow can lead to overheating and consequentially, engine damage.

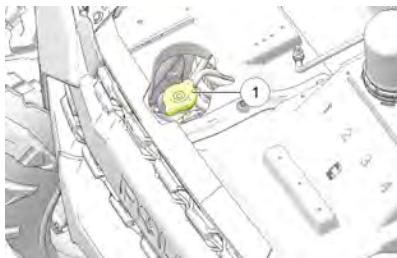

1. Lift the hood.

#### CAUTION

Escaping steam can cause burns. Never remove the pressure cap while the engine is warm or hot. Always allow the engine to cool before removing the pressure cap.

2. Slowly remove the radiator cap ①.
3. View the coolant level through the opening.
4. Use a funnel and slowly add coolant as needed.

#### TIP

This procedure is required only if the cooling system has been drained for maintenance and/or repair. But if the overflow bottle has run dry, the level in the radiator should also be inspected.

5. Reinstall the pressure cap. Use of a non-standard pressure cap will not allow the recovery system to function properly. Your POLARIS dealer can provide the correct replacement part.

## OVERFLOW BOTTLE COOLANT LEVEL

Always check and change the coolant at the intervals outlined in the Periodic Maintenance Chart. Maintain the coolant level between the minimum and maximum marks on the bottle (when the fluid is cool).

1. Position the vehicle on a level surface.
2. Lift the hood. View the coolant level in the overflow bottle ①.

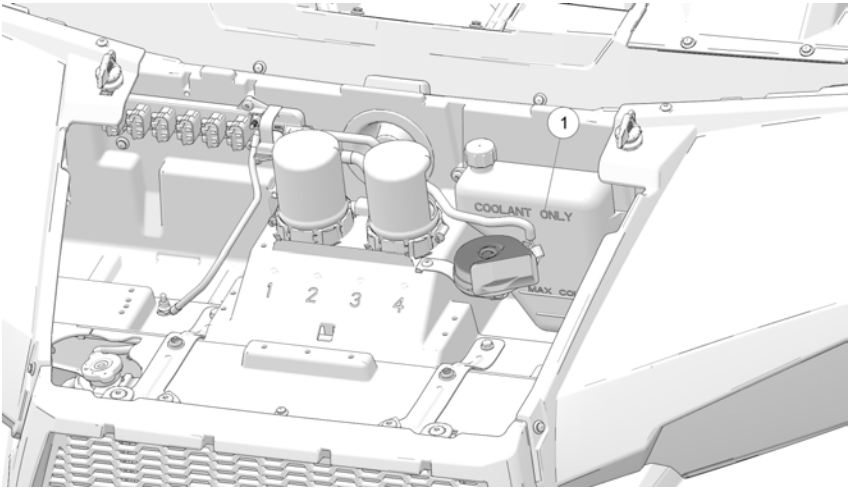

3. If the coolant level is below the safe operating range, lift the hood and locate the overflow bottle lid. Remove the cap and use a funnel to add coolant through the filler opening. Reinstall the cap.

### TIP

If coolant must be added often, or if the overflow bottle runs completely dry, there may be a leak in the system. Your dealer can inspect the cooling system.

### FUEL LEAK INSPECTION

1. Lift the driver's seat and the box to gain access fuel lines.

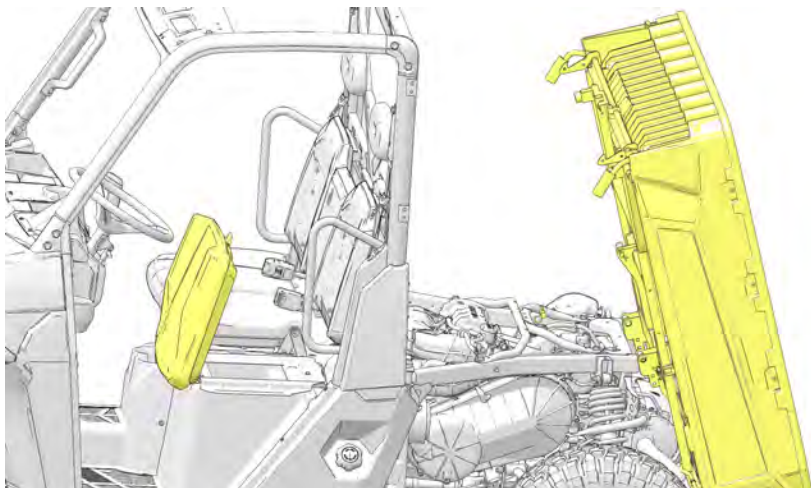

2. Inspect all fuel lines for leaks, cracks, and loose connections.

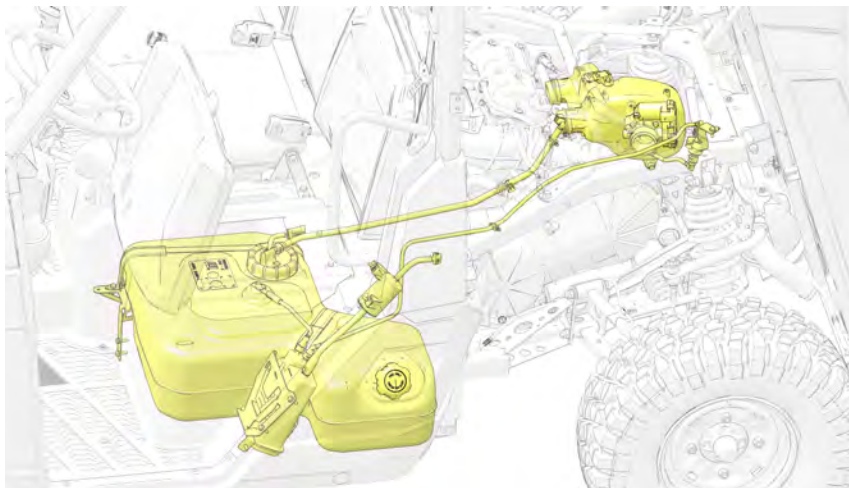



## POLARIS VARIABLE TRANSMISSION (PVT) SYSTEM

### WARNING

Failure to comply with the instructions in this warning can result in severe injury or death. Do not modify any component of the PVT system. Doing so may reduce its strength so that a failure may occur at a high speed. The PVT system has been precision balanced. Any modification will cause the system to be out of balance, creating vibration and additional loads on components.

The PVT system rotates at high speeds, creating large amounts of force on clutch components. As the owner, you have the following responsibilities for your own safety and the safety of others:

- Always follow all recommended maintenance procedures. Always look for and remove debris inside and around the clutch and vent system when replacing the belt.
- See your dealer or other qualified service person as outlined in the owner's manual.
- This PVT system is intended for use on POLARIS products only. Do not install it in any other product.
- Always make sure the PVT housing is securely in place during operation.

## MAINTENANCE

### BELT REMOVAL

If a belt fails, always clean any debris from the clutch air duct and from the clutch and engine compartments when replacing the belt.

#### WARNING

Failure to remove ALL debris when replacing the belt could result in vehicle damage, loss of control and severe injury or death.

#### NOTE

Inspect the entire clutch outlet duct (including the outlet duct screen) when replacing a drive belt. Remove any debris found in the outlet duct or outlet duct screen.

To remove the belt, do the following:

1. Remove the nine fasteners ① that retain the outer clutch cover.

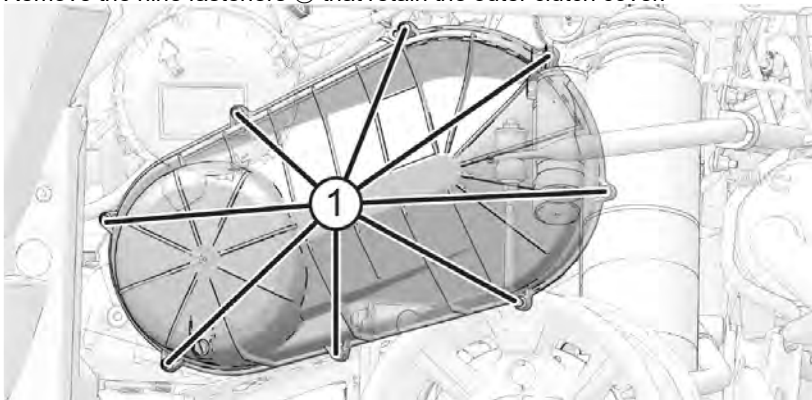

#### NOTE

Removal of left rear wheel or left rear shock is NOT necessary for belt replacement.

2. To remove the clutch cover, pull the cover (starting at the bottom), lift up over the suspension, and then out of the vehicle.

#### NOTE

Use care when lifting clutch cover upwards. Do not damage cover, intake boot, or electrical harness.

3. Mark the drive belt direction of rotation so that it can be installed in the same direction.
4. Insert clutch spreader tool ② into threaded hole on driven clutch as shown and turn clockwise to spread clutch.

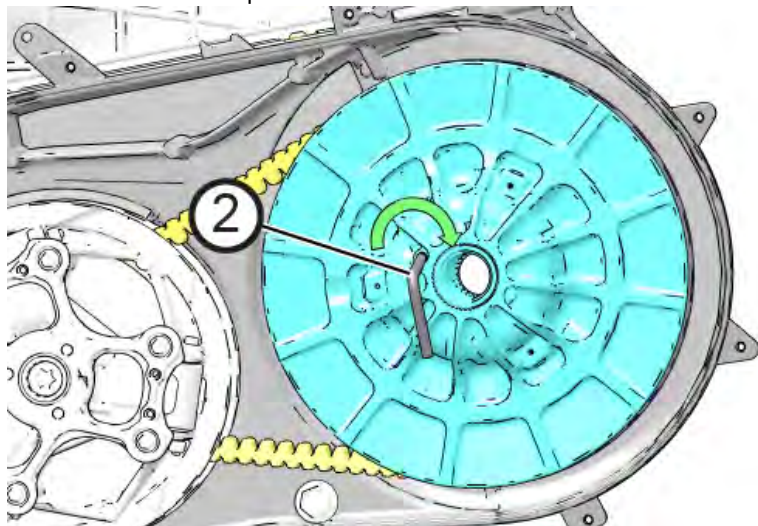

## NOTE

The part number for the clutch spreader tool is 2875911.

5. Walk the belt out of the driven clutch and drive clutch. Remove the belt from the vehicle.

## BELT INSPECTION

To inspect the drive belt, do the following:

1. Inspect belt for hour-glassing (extreme circular wear in at least one spot and on both sides of the belt). Hour glassing occurs when the drive train does not move and the drive clutch engages the belt.
2. Inspect belt for loose cords, missing cogs, cracks, abrasions, thin spots, or excessive wear. Compare belt measurements with a new drive belt. Replace if necessary.
3. Belts with thin spots, burn marks, etc., should be replaced to eliminate noise, vibration, or erratic PVT operation.

### BELT INSTALLATION

#### NOTE

Be sure to install belt in the same direction as it was removed.

1. With the clutch spreader tool ① installed, loop the belt over the drive clutch and over the driven clutch.

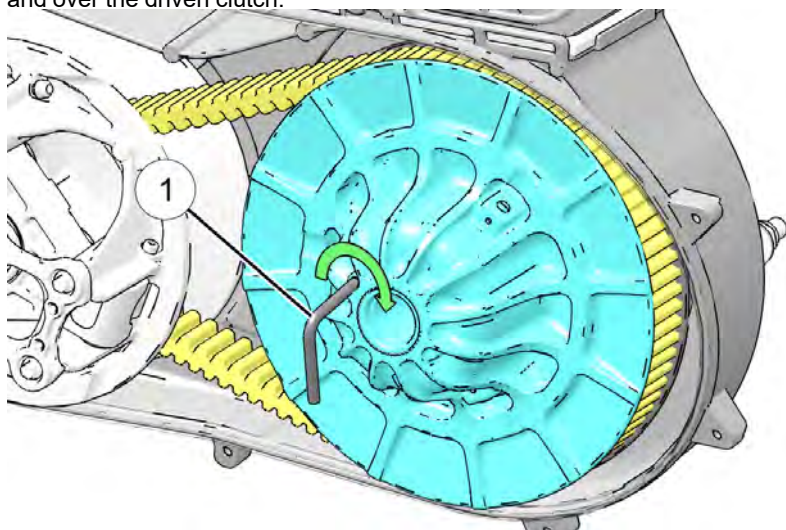

2. Rotate the driven clutch and walk the belt into the clutch.
3. Turn the clutch spreader tool counterclockwise to remove from the driven clutch.
4. Rotate / spin the driven clutch and belt approximately 5-7 times to properly seat the belt in the driven clutch.

5. Install the clutch cover into wheel well by installing the top half first, then the bottom half over the suspension.

### NOTE

Use care when installing the clutch cover. Do not damage cover, intake boot, or electrical harness.

6. Install and torque the outer clutch cover bolts② to specification.

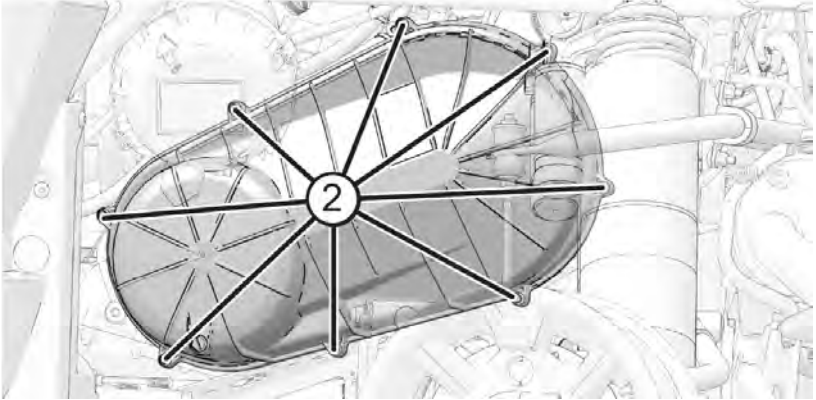

### TORQUE

PVT Outer Cover Fasteners: **44 in-lbs (5 N·m)**

## MAINTENANCE

---

### **POLARIS VARIABLE TRANSMISSION (PVT) DRYING**

There may be some instances when water is ingested into the PVT system. Use the following instructions to dry it out before operating:

1. Position the vehicle on a level surface.
2. Remove the red drain plug on the outer clutch cover. Allow the water to drain completely. Reinstall the drain plug.
3. Place the transmission in PARK.
4. Start the engine.
5. Apply varying throttle for 10-15 seconds to expel the moisture and air-dry the belt and clutches. Do not hold the throttle wide open for more than five (5) seconds.
6. Allow the engine RPM to settle to idle speed. Apply the brakes. Shift the transmission to the lowest available range.
7. Test for belt slippage. If the belt slips, repeat the process.
8. Your vehicle requires service as soon as possible. Your POLARIS dealer can assist.

### **SHIFT CABLE / LINKAGE INSPECTION**

Ensure that shift cable/linkage is clean, free of debris, operation is smooth and cable boot is not damaged. If operation is not smooth or if the cable boot is damaged or torn, contact an authorized dealer for service.

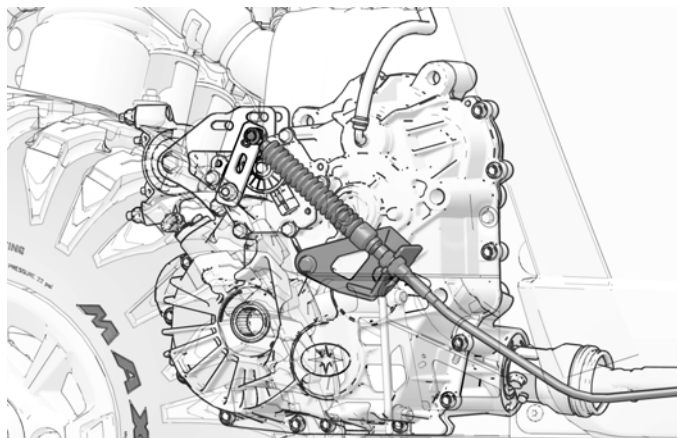

---

## VEHICLE IMMERSION

 **WARNING**

If your vehicle becomes immersed, major engine damage can result if the machine is not thoroughly inspected. Take the vehicle in for service before starting the engine. Your POLARIS dealer can provide this service.

If it's impossible to take your vehicle to a dealer before starting it, follow the steps outlined below:

1. Move the vehicle to dry land or at the very least, to water below the footrests.
2. Dry any water present in the air box. Filter replacement is required if water is present.
3. Remove the spark plugs. Turn the engine over several times using the electric start.
4. Dry the spark plugs and reinstall, or replace with new plugs.
5. Attempt to start the engine. If necessary, repeat the drying procedure.
6. Take the vehicle in for service as soon as possible, whether you succeed in starting it or not. Your POLARIS dealer can provide the required service.
7. If water has been ingested into the PVT follow the procedure for drying.

## FILTER SYSTEMS

### AIR FILTER INSPECTION / REPLACEMENT

Inspect the air filter at the intervals outlined in the Periodic Maintenance Chart. In extremely dusty conditions, air filter replacement will be required more often.

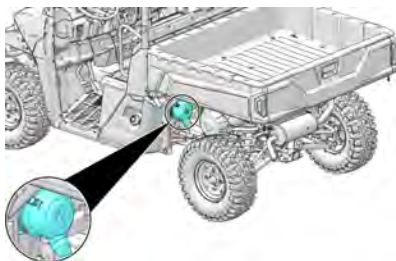

1. Locate the air filter on the left side of the unit.
2. Release the two airbox ② cover latches.

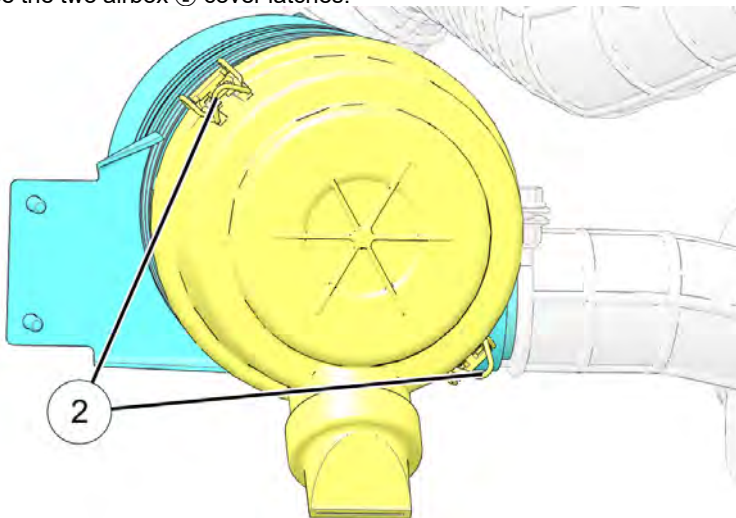



- Remove the cover ③ to access the air filter element ④.

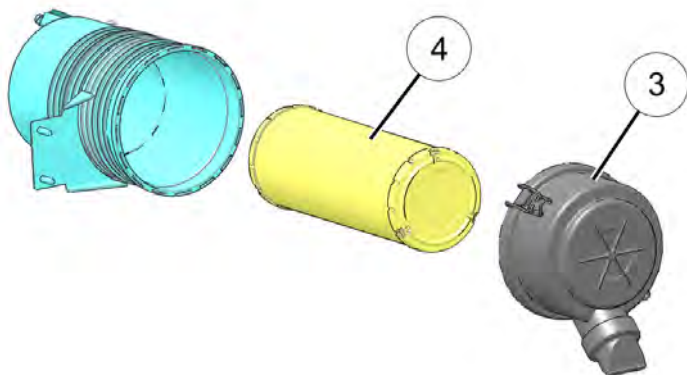

- Inspect the airbox for oil or water deposits. Wipe away any deposits with a clean shop towel.

### NOTICE

Air filter removal is not needed for inspection-only.

### IMPORTANT

If the filter has been soaked with fuel or oil it must be replaced.  
DO NOT attempt to clean the air filter.

- Place the air filter into the airbox. Reposition the airbox cover and install the two retaining latches.

### NOTICE

Make sure the hinge pins are properly seated when reassembling the airbox

## MAINTENANCE

---

### AIR INTAKE / ENGINE BREATHER INSPECTION

1. Inspect the intake ducts between the filter and engine for loose connections, cracking, etc. Ensure clamps are tight.

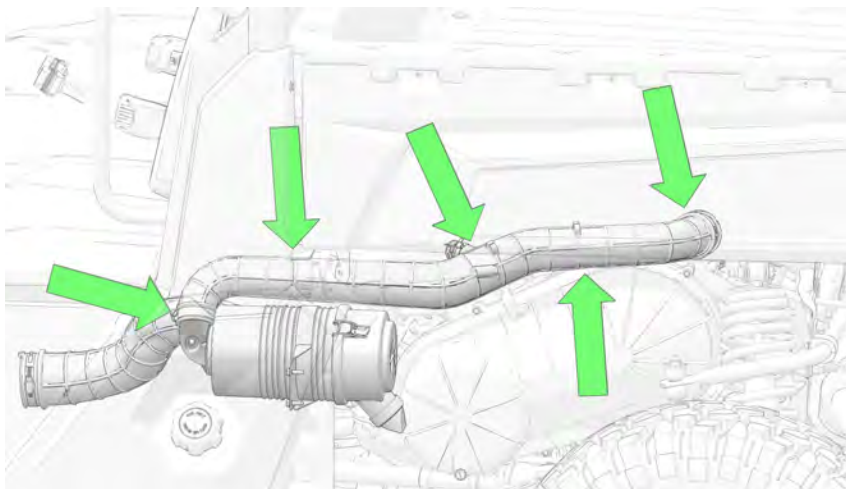

2. Inspect the engine breather for loose connections, cracking, etc. Ensure clamps are tight.

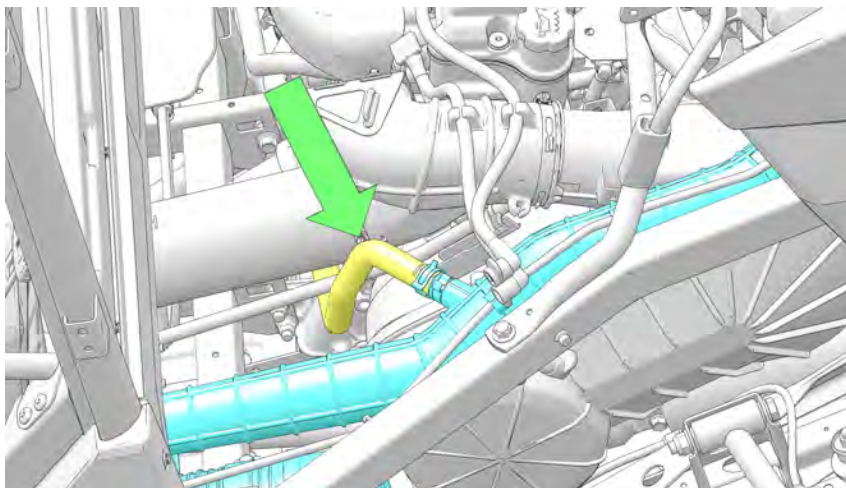

## SPARK ARRESTER

### WARNING

- Never operate the vehicle without the spark arrester.
- Remove any combustible materials from the area.

**Failure to heed the following warnings while servicing the spark arrester could result in serious injury or death.**

- Never run the engine in an enclosed area. Exhaust contains poisonous carbon monoxide gas that can cause loss of consciousness or death in a very short time.
- Do NOT perform service on the spark arrester while the system is HOT. Exhaust system temperatures can reach extreme temperatures. Allow components to cool sufficiently before proceeding.
- Do not stand behind or in front of the vehicle while purging the exhaust system.
- Never go under the vehicle while it is inclined.
- Wear eye protection and gloves while servicing.

Use the following procedure to periodically purge accumulated carbon from the exhaust pipe.

1. Turn off engine and allow exhaust to cool sufficiently.
2. Remove the spark arrester from the tailpipe of the muffler.
3. Remove any debris from spark arrester and the tailpipe.
4. Inspect spark arrester for holes in mesh screen. Replace as needed.
5. Replace spark arrester and torque bolt to specification.

### TORQUE

Spark Arrester Bolt: **8 ft-lbs (11 N·m)**

### BRAKES

The front and rear brakes are hydraulic disc type brakes. Press down on the brake pedal to engage the brakes.

### BRAKE FLUID

Inspect the brake system routinely. Inspect the level of the brake fluid before each operation.

 **WARNING**

After opening a bottle of brake fluid, always discard any unused portion. Never store or use a partial bottle. Brake fluid is hygroscopic, meaning it rapidly absorbs moisture from the air. The moisture causes the boiling temperature of the brake fluid to drop, which can lead to early brake fade and the possibility of accident or severe injury.

Change the brake fluid every two years and any time the fluid becomes contaminated, the fluid level is below the minimum, or if the type and brand of the fluid in the reservoir are unknown.

1. Position the vehicle on a level surface and turn off the engine.
2. View the brake fluid level at the reservoir in the driver's side wheel well. The level should be between the upper (MAX) and lower (MIN) level lines.
3. If the fluid level is lower than the upper level line, open the hood and add brake fluid to the upper (MAX) line.
4. Apply the brake forcefully for a few seconds and check for fluid leakage around the fittings.

## BRAKE INSPECTION

### WARNING

Do not apply WD-40® or any petroleum product to brake discs. These types of products are flammable and may also reduce the friction between the brake pad and caliper.

1. Check the brake system for fluid leaks.
2. Check the brake pedal for excessive travel or a spongy feel.
3. Check the friction pads for wear, damage and looseness.
4. Check brake discs for signs of cracks, excessive corrosion, warping or other damage. Clean any grease using an approved brake cleaner or alcohol.
5. Inspect the brake disc spline and pad wear surface  for excessive wear. Change pads when worn to 0.040 in (1 mm).

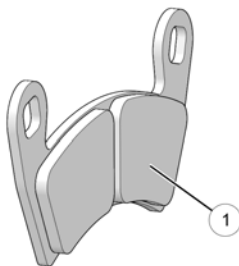

## STEERING INSPECTION

Check the steering for specified freeplay, smooth operation, and inspect the steering boots at the intervals outlined in the Periodic Maintenance Chart section.

1. Position the vehicle on level ground.
2. Lightly turn the steering wheel left and right.
3. There should be 0.8-1.0 in (20-25 mm) of freeplay.

## MAINTENANCE

---

4. If there is excessive free play or strange noises, or the steering feels rough or “catchy,” have the steering system inspected by an authorized dealer.
5. Inspect boots ① for tears. If a tear is discovered, have the boot replaced by an authorized dealer.

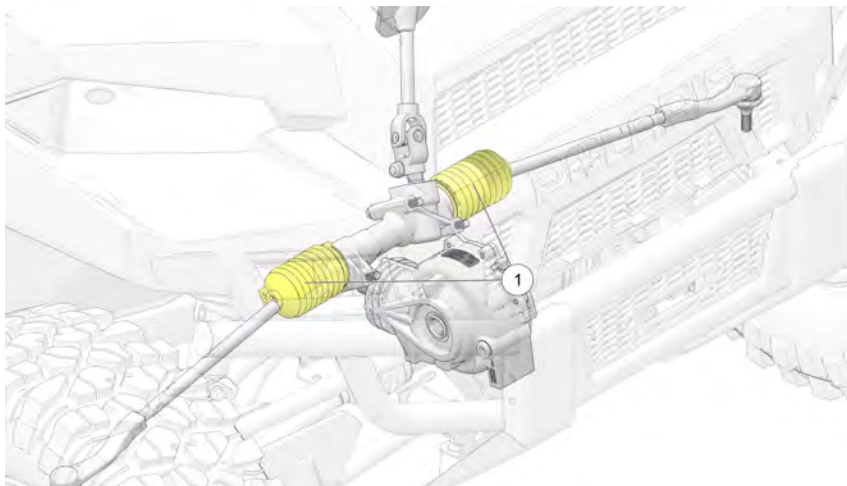

## WHEEL BEARING INSPECTION

1. Elevate front end of machine so front wheels are off the ground.
2. Check for any looseness in front wheel/hub assembly by grasping the tire firmly at top and bottom first, and then at front and rear. Try to move the wheel and hub by pushing inward and pulling outward.

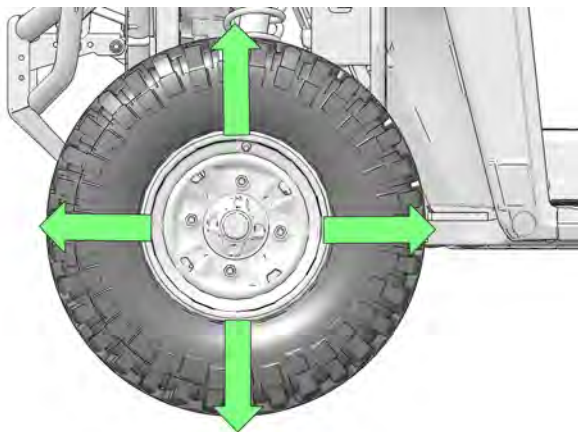

3. If abnormal movement is detected, take the vehicle to your dealer for service.
4. Repeat the procedure for the rear wheels.

## AXLE INSPECTION

Inspect inboard and outboard boots on both sides of the vehicle, front ① and rear ②, for tears. If a tear is discovered, have the boot replaced by an authorized dealer.

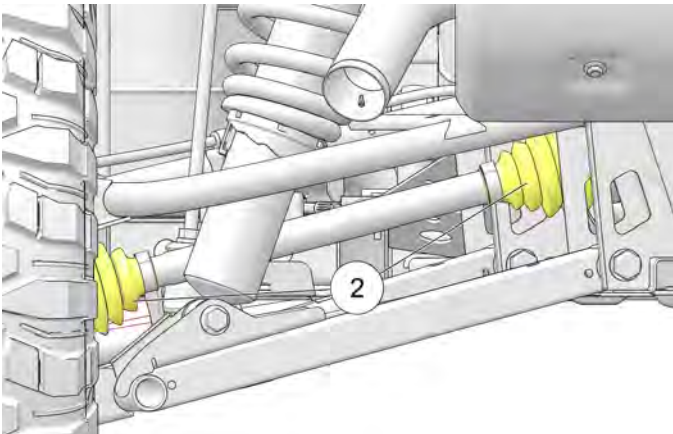
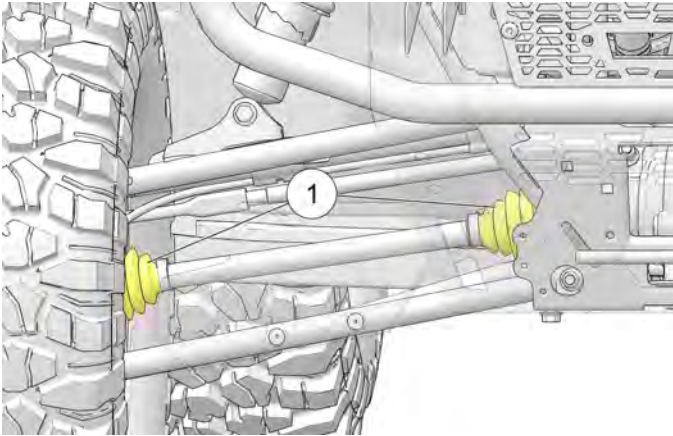

## MAINTENANCE

### SPRING ADJUSTMENT (IF APPLICABLE)

Adjust the front and rear shock absorber springs by rotating the adjustment cam ① either clockwise or counterclockwise to increase or decrease spring tension.

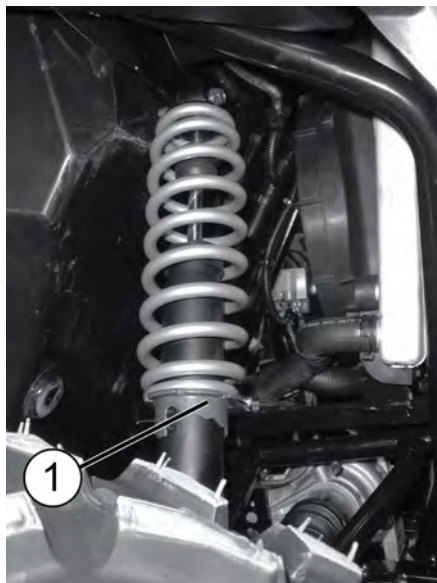

## TIRES

### WARNING

Operating your vehicle with worn tires will increase the possibility of skidding, loss of control and an accident, which could result in serious injury or death. Always replace tires when the tread depth measures 1/8 in (3 mm) or less.

Improper tire inflation or the use of non-standard size or type of tires may adversely affect vehicle handling, which could result in vehicle damage or personal injury. Always maintain proper tire pressure. Always use POLARIS approved size and type of tires for this vehicle when replacing tires.

### TIRE TREAD DEPTH

Always replace tires when tread depth is worn to 1/8 in (3 mm) or less.



## TIRE ROTATION

Tire rotation is recommended for every 500 miles (800 km) interval. Perform tire rotation on the vehicle by following the rearward cross strategy as shown.

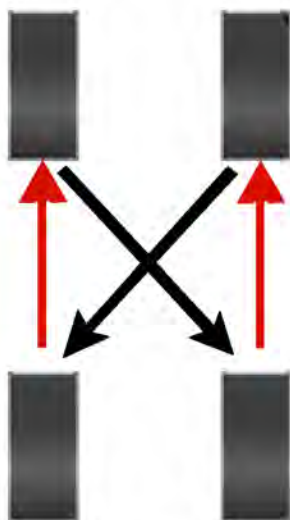

## AXLE AND WHEEL NUT TORQUE SPECIFICATIONS

Inspect the following items occasionally for tightness, and if they've been loosened for maintenance service. Do not lubricate the stud.

2-Piece Flange Nut 	Front and Rear	60 ft-lbs (81 N·m)
Spindle Nut	Front	110 ft-lbs (149 N·m)
Hub Retaining Nut	Rear	180 ft-lbs (244 N·m)

## WHEEL REMOVAL

1. Position the vehicle on a level surface.
2. Place the transmission in PARK. Stop the engine.
3. Loosen the wheel nuts slightly.
4. Elevate the side of the vehicle by placing a suitable stand under the frame.
5. Remove the wheel nuts and washers. Remove the wheel.

## MAINTENANCE

---

### WHEEL INSTALLATION

#### WARNING

Improperly installed wheels can adversely affect tire wear and vehicle handling, which can result in serious injury or death. Always ensure that all nuts are torqued to specification. Do not service axle nuts that have a cotter pin installed. Your dealer can assist.

1. Place the transmission in PARK.
2. Place the wheel on the hub with the valve stem toward the outside and rotation arrows on the tire pointing toward forward rotation.
3. Attach the wheel nuts and washers and finger-tighten.
4. Carefully lower the vehicle to the ground.
5. Torque the wheel nuts to specification.

### POWER STEERING UNIT (IF EQUIPPED)

If your model is equipped with power steering, frequently clean the areas around and on the power steering unit to allow proper cooling. Clean these areas ③ thoroughly.

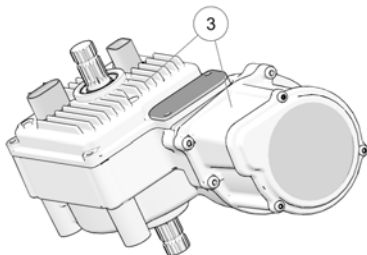

### LIGHTS

Poor lighting can result in reduced visibility when driving. Headlight and taillight lenses become dirty during normal operation. Clean lights frequently and replace burned out lamps promptly. Do not operate this vehicle at night or in low light conditions until the headlight is replaced. Always make sure lights are adjusted properly for best visibility.

When servicing a halogen lamp, don't touch the lamp with bare fingers. Oil from your skin leaves a residue, causing a hot spot that will shorten the life of the lamp.

### HEADLIGHT BULB REPLACEMENT

1. Remove the hood from the front cab.
2. Locate the bulb on the back side of the headlight housing.

3. Disconnect the harness from the bulb. Be sure to pull on the connector, not on the wiring.

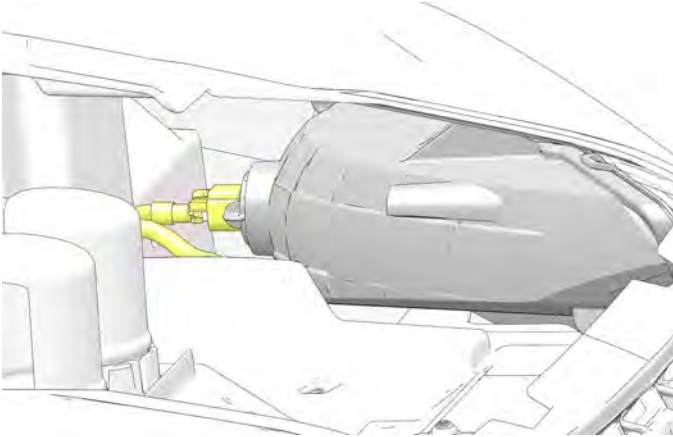

4. Turn the bulb counterclockwise and remove it from the headlight housing.

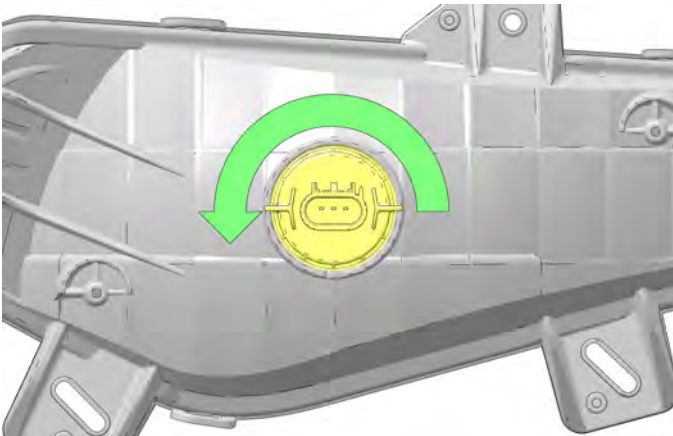

5. Install the new bulb into the housing and rotate it clockwise 90° to lock it in place.

### NOTICE

Make sure the tab on the bulb locates properly in the housing.

6. Install the harness onto the new headlight bulb and install the hood.

## MAINTENANCE

---

### HEADLIGHT BEAM ADJUSTMENT

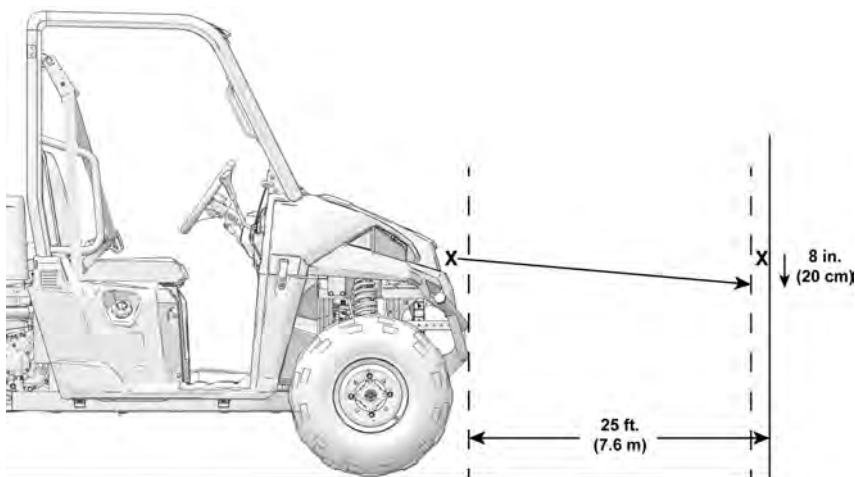

To adjust the headlight beam, do the following:

1. Place the vehicle on a level surface with the headlight approximately 25 ft (7.6 m) from a wall.
2. Measure the distance from the floor to the center of the headlight and make a mark on the wall at the same height.
3. Apply the brakes. Start the engine. Turn on the headlights.
4. Observe the headlight aim. The most intense part of the headlight beam should be aimed 8 in (20 cm) below the mark placed on the wall. Include the weight of a rider on the seat while performing this step.
5. If a headlight needs adjustment, locate the adjustment screw at the back of the headlight.
6. Loosen the screw, adjust the headlight, and tighten the screw.
7. Repeat steps 4-6 until the lamp is properly adjusted.

### BRAKE LIGHTS

When the brake pedal is depressed, the brake light comes on. Check the brake light before each ride.

To check the brake lights, do the following:

1. Turn the key to the ON position.
2. Depress the brake pedal. The brake light should come on after about 0.4 in (10 mm) of pedal travel. If the light doesn't come on, check the bulb.

## FUSES

If the engine stops or will not start, or if you experience other electrical failures, a fuse may need replacement. Locate and correct any short circuits that may have caused the blown fuse, then replace the fuse. The fuse box is located under the seat, next to the battery

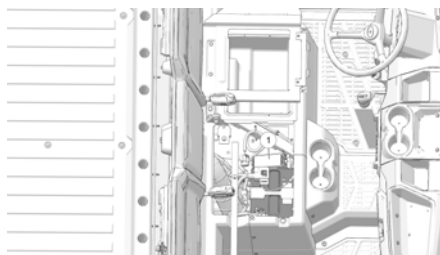

①. Spare fuses are provided in the fuse box.

If you suspect that a fuse or relay may not be working properly, your dealer can assist.

FUSE SIZE	FEATURE SUPPORTED
30A	EPS
20A	Accessories
20A	Chassis
15A	Key Switch
15A	Lights
10A	Charge Receptacle
10A	Drive Mode
10A	EFI (Engine Controller)
10A	Fuel Pump
10A	Horn (labeled "Audible")
5A	Switches

## BATTERY

Your vehicle has a sealed battery, which requires little maintenance. Always keep battery terminals and connections free of corrosion. If cleaning is necessary, remove the corrosion with a stiff wire brush. Wash with a solution of one tablespoon baking soda and one cup water. Rinse well with tap water and dry off with clean shop towels. Coat the terminals with dielectric grease or petroleum jelly.

## MAINTENANCE

---

### BATTERY REMOVAL

#### WARNING

Improperly connecting or disconnecting battery cables can result in an explosion and cause serious injury or death. When removing the battery, always disconnect the negative (black) cable first. When reinstalling the battery, always connect the negative (black) cable last.

1. Remove the storage bin under the passenger seat to access the battery.
2. Disconnect the black (-) battery cable first. Disconnect the red (+) battery cable last.
3. Remove the battery hold-down strap.
4. Lift the battery out of the vehicle.

### BATTERY INSTALLATION

Using a new battery that has not been fully charged can damage the battery and result in a shorter life. It can also hinder vehicle performance. Follow the battery charging instructions before installing the battery.

1. Ensure that the battery is fully charged.
2. Place the fully charged battery in the battery holder. Make sure the positive terminal is toward the driver's side of the vehicle.
3. Coat the terminals with dielectric grease or petroleum jelly.
4. Connect and tighten the red (+) cable first. Connect and tighten the black (-) cable last.
5. Install the hold-down strap.
6. Reinstall the storage bin and seat.

### BATTERY STORAGE

Whenever the vehicle is not used for a period of three months or more, remove the battery from the vehicle, ensure that it's fully charged, and store it out of the sun in a cool, dry place. Check battery voltage each month during storage and recharge as needed to maintain a full charge.

#### TIP

Battery charge can be maintained by using a POLARIS Battery Tender charger or by charging about once a month to make up for normal self discharge.

Battery Tender can be left connected during the storage period, and will automatically charge the battery if the voltage drops below a predetermined point. See the Polaris Products section for the part numbers.

## BATTERY CHARGING

The following battery charging instructions apply only to the installation of a sealed battery. Read all instructions before proceeding with the installation of this battery.

The sealed battery is already filled with electrolyte and has been sealed and *fully charged* at the factory. *Never* pry the sealing strip off or add any other fluid to this battery.

The single most important thing about maintaining a sealed battery is to keep it fully charged. Since the battery is sealed and the sealing strip cannot be removed, you must use a voltmeter or multimeter to measure DC voltage.

 **WARNING**

An overheated battery may explode, causing severe injury or death. Always watch charging times carefully. Stop charging if the battery becomes very warm to the touch. Allow it to cool before resuming charging.

For a refresh charge, follow all instructions carefully.

1. Check the battery voltage with a voltmeter or multimeter. A fully charged battery will register 12.8 V or higher.
2. If the voltage is less than 12.8 volts, recharge the battery at 1.2 amps or less until battery voltage is 12.8 or greater.
3. When using an automatic charger, refer to the charger manufacturer's instructions for recharging. When using a constant current charger, use the guidelines below for recharging.

*Always verify battery condition before and 1-2 hours after the end of charging.*

STATE OF CHARGE	VOLTAGE	ACTION	CHARGE TIME*
100%	12.8-13.0 volts	None, check at 3 mos. from date of manufacture	None required
75%-100%	12.5-12.8 volts	May need slight charge, if no charge given, check in 3 months	3-6 hours
50%-75%	12.0-12.5 volts	Needs charge	5-11 hours

## MAINTENANCE

STATE OF CHARGE	VOLTAGE	ACTION	CHARGE TIME*
25%-50%	11.5-12.0 volts	Needs charge	At least 13 hours, verify state of charge
0%-25%	11.5 volts or less	Needs charge with desulfating charger	At least 20 hours

\*(Using constant current charger @ standard amps specified on top of battery)



## CLEANING AND STORAGE

### WASHING THE VEHICLE

Keeping your POLARIS vehicle clean will not only improve its appearance but it can also extend the life of various components.

**NOTICE**

High water pressure may damage components. POLARIS recommends washing the vehicle by hand or with a garden hose, using mild soap.

**NOTICE**

Certain products, including insect repellents and chemicals, will damage plastic surfaces. Do not allow these types of products to contact the vehicle.

The best and safest way to clean your POLARIS vehicle is with a garden hose and a pail of mild soap and water.

1. Use a professional-type washing cloth, cleaning the upper body first and the lower parts last.
2. Rinse with clean water frequently.
3. Dry surfaces with a chamois to prevent water spots.

### WASHING TIPS

- Avoid the use of harsh cleaners, which can scratch the finish.
- Do not use a power washer to clean the vehicle.
- Do not use medium to heavy duty compounds on the finish.
- Always use clean cloths and pads for cleaning and polishing. Old or reused cloths and pads may contain dirt particles that will scratch the finish.
- Grease all zerk fittings immediately after washing. Allow the engine to run for a while to evaporate any water that may have entered the engine or exhaust system.

If a high pressure water system is used for cleaning (not recommended), exercise extreme caution. The water may damage components and could remove paint and labels. Avoid directing the water stream at the following items:

- |                            |                                    |
|----------------------------|------------------------------------|
| • Wheel bearings           | • Cab and body panels              |
| • Radiator                 | • Labels and decals                |
| • Transmission seals       | • Electrical components and wiring |
| • Brakes                   | • Air intake components            |
| • Door seals (if equipped) | • Window seals (if equipped)       |

## MAINTENANCE

---

If an informational or graphic label becomes illegible or comes off, contact your POLARIS dealer, or other qualified person, to purchase a replacement. Replacement safety labels are provided by POLARIS at no charge.

### POLISHING THE VEHICLE

POLARIS recommends the use of common household aerosol furniture polish for polishing the finish on your POLARIS vehicle. Follow the instructions on the container.

#### ***POLISHING TIPS***

- Avoid the use of automotive products, some of which can scratch the finish of your vehicle.
- Always use clean cloths and pads for cleaning and polishing. Old or reused cloths and pads may contain dirt particles that will scratch the finish.

### STORAGE TIPS

#### *NOTICE*

Starting the engine during the storage period will disturb the protective film created by fogging and damage could occur. Never start the engine during the storage period.

#### ***CLEAN THE EXTERIOR***

Make any necessary repairs and clean the vehicle as recommended.

#### ***OIL AND FILTER***

Change the oil and filter. See the Engine Oil section.

#### ***AIR FILTER / AIR BOX***

Replace the air filter. See Maintenance Chapter. Clean the air box.

#### ***FLUID LEVELS***

Inspect the fluid levels. Add or change fluids as recommended in the Periodic Maintenance Chart.

- Demand drive fluid (front gearcase)
- Rear gearcase fluid (if equipped)
- Transmission fluid
- Brake fluid (change every two years and any time the fluid looks dark or contaminated)
- Coolant (test strength/fill)

## INSPECT AND LUBRICATE

Inspect all cables and lubricate all areas of the vehicle as recommended in the Periodic Maintenance Chart.

## STORAGE AREA / COVERS

Be sure the storage area is well ventilated. Cover the vehicle with a genuine POLARIS cover. Do not use plastic or coated materials. They do not allow enough ventilation to prevent condensation, and may promote corrosion and oxidation.

## REMOVAL FROM STORAGE

1. Charge the battery if necessary. Install it in the vehicle.
2. Fill the fuel tank with fuel.
3. Check all the points listed in the Daily Pre-Ride Inspection section. *Tightness of the bolts, nuts and other fasteners should be checked by an authorized POLARIS dealer.*
4. Lubricate at the intervals outlined in the Periodic Maintenance Chart.

## TRANSPORTING THE VEHICLE

### LOADING AND UNLOADING

The weight distribution of the cargo loaded onto the trailer is important and will have an impact on how the vehicle handles on the road. Ensure the weight of the cargo is distributed properly and the trailer is not rear, front, or side heavy.

Always use a spotter if you are uncomfortable loading the vehicle on your own. A wheel chock or marker can also be used as an indication of how close you will park the vehicle from the front of the trailer.



**WARNING**

When loading or unloading a vehicle onto a trailer, always wear the appropriate safety gear, including an approved helmet.

### MINIMUM WORKING LOAD LIMIT



**WARNING**

Always secure cargo properly. Improperly securing a load can result in severe injury or death.

Securing devices, such as tie-down straps, are manufactured to support a load that can be applied during normal service. This is known as the Working Load Limit (WLL).

# MAINTENANCE

---

VEHICLE TYPE	TIE-DOWN MINIMUM WLL
All Vehicles	3,300 lb (1497 kg)

## TRANSPORTING THE VEHICLE

Follow these procedures when transporting the vehicle.

### NOTICE

Do not tow your vehicle behind a car or other vehicle except on a trailer.

1. Properly load the vehicle onto the trailer or towing vehicle.
2. Apply the brakes.
3. Place the transmission in PARK. Stop the engine.
4. Slowly release the brake pedal and make sure the transmission is in PARK before exiting the vehicle.
5. Remove the key to prevent loss during transporting.
6. Ensure that all seats are attached correctly and are not loose.
7. Secure the fuel cap, and doors (if equipped).

### WARNING

Cargo and other loose vehicle parts may fall off while transporting the vehicle. Secure or remove all cargo, and inspect the unit for loose parts prior to transport.

### WARNING

Do not exceed the towing vehicle's or trailer's towing capacity when transporting. Refer to the towing vehicle and trailer's specifications.

### WARNING

If transporting the vehicle in a non-enclosed trailer, the vehicle must FACE FORWARD, or the roof must be removed. Failure to comply may allow airflow, vibration, or other factors to separate the roof from the vehicle and cause an accident, resulting in serious personal injury or death.

## MAINTENANCE

---

8. Using tie-down straps of suitable Working Load Limit (WLL), secure the vehicle to the trailer at the designated tie-down points (front and rear). The straps must be secured in a manner that provides support in both vertical and lateral directions. Ensure that they are set with enough tension as to compress the suspension and prevent vehicle movement during transport. Do not allow the secured straps to make contact with any other part of the trailer or cargo.

 CAUTION

Always use the provided tie-down points. Not using the provided vehicle tie-down points could lead to premature component failure and/or excess wear on the tie-down straps.

 WARNING

Always secure the vehicle with at least four straps when trailering. Use two straps in the front, and two in the rear.

 WARNING

Never use chains to tie down the vehicle.

 WARNING

Do not lay straps over any sharp edges. Sharp edges may damage straps during transportation.

9. Periodically inspect the vehicle and trailer during transit. Adjust cargo and straps as needed to ensure that the cargo cannot shift, or fall from the trailer or towing vehicle.

## TIE-DOWN LOCATIONS

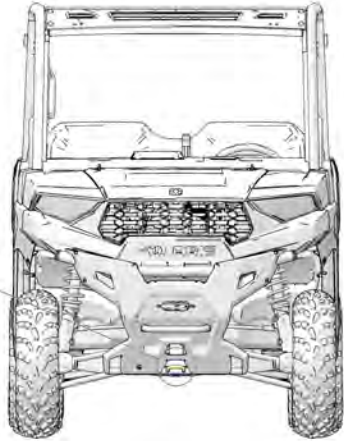
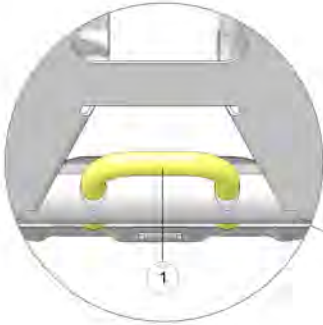

① Front tie-down point

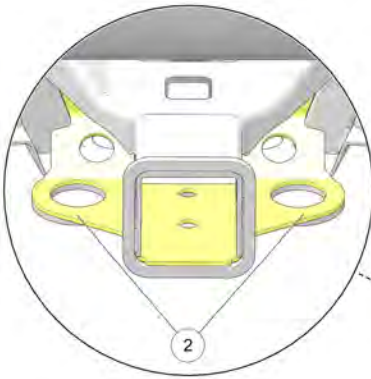

② Rear tie-down points





# SPECIFICATIONS

## PRO XD STANDARD CAB

PRO XD STANDARD CAB	
Maximum Weight Capacity	1900 lb (861 kg) (including operator, passenger, cargo, accessories)
Dry Weight	1599 lb (725 kg)
GVWR – Gross Vehicle Weight Rating	3600 lb (1633 kg) per ANSI/OPEI B71.9-2016, Section 5.1.2
Fuel Capacity	11.5 gal (43.5 L)
Engine Oil Capacity	2.5 qt (2.4 L)
Coolant Capacity	5.8 qt (5.5 L)
Towing Capacity	2500 lb (1134 kg)
Hitch Tongue Capacity	250 lb (113 kg)
Max. Cargo Box Load	1250 lb (566 kg)
Overall Length	126 in (320 cm)
Overall Width	62.5 in (158.8 cm)
Overall Height	75 in (191 cm)
Wheelbase	85 in (215.9 cm)
Cargo Box Dimensions (Inside)	54 in (137 cm) wide, 43.5 in (110 cm) long, 11.5 in (29 cm) high
Ground Clearance	11 in (27.9 cm)
Min. Turning Radius	112 in (284.5 cm)
Engine	4-Stroke SOHC Twin Cylinder
Displacement	999 cm <sup>3</sup>
Bore x Stroke	(93 mm) x (73.5 mm)

## SPECIFICATIONS

<b>PRO XD STANDARD CAB</b>	
Stator Output	900 W @ 3000 RPM
Compression Ratio	10.5:1
Starting System	Electric
Fuel System	Electronic fuel injection
Ignition Timing	ECU Controlled 32° +/- 2° @ 5000 RPM
Spark Plug/ Gap	Autolite 5684 / 0.03 in (0.85 mm)
Front Suspension	Dual A-arm w/ 9 in (22.86 cm) of travel
Rear Suspension	Independent w/ 9 in (22.86 cm) of travel
Ignition System	Digital CDI
Lubrication System	Wet Sump
Driving System Type	PVT
Shift Type	Single Lever (H/L/N/R/P)
Gear Reduction - Low	Front 8.56:1/ Rear 25.59:1
Gear Reduction - Reverse	Front 7.67:1 / Rear 22.92:1
Gear Reduction - High	Front 4.03:1 / Rear 12.05:1
Drive Ratio - Front	42.11:1 (non-EPS) 42.13:1 (EPS)
Tire Size - Front	26 x 10 - 12
Tire Size - Rear	26 x 10 - 12
Tire Pressure - Front	5 psi (34 kPa)
Tire Pressure - Rear	20 psi (138 kPa)
Brakes, Front/Rear	Foot Activated, 4 wheel hydraulic disc
Hood Headlight	2 single beam, 50W, quartz/halogen

<b>PRO XD STANDARD CAB</b>	
Taillights	10 L.E.D. (.28W)
Brake Light	10 L.E.D. (3.1W)

## **PRO XD CREW CAB**

<b>PRO XD CREW CAB</b>	
Maximum Weight Capacity	2075 lb (941 kg) (including operator, passengers, cargo, accessories)
Dry Weight	1912 lb (867 kg)
GVWR – Gross Vehicle Weight Rating	4000 lb (1814 kg) per ANSI/OPEI B71.9-2016, Section 5.1.2
Fuel Capacity	11.5 gal (43.5 L)
Engine Oil Capacity	2.5 qt (2.4 L)
Coolant Capacity	6.6 qt (6.25 L)
Towing Capacity	2500 lb (1134 kg)
Hitch Tongue Capacity	250 lb (113 kg)
Max. Cargo Box Load	1250 lb (566 kg)
Overall Length	157 in (399 cm)
Overall Width	62.5 in (158.8 cm)
Overall Height	75 in (191 cm)
Wheelbase	117 in (297 cm)
Cargo Box Dimensions (Inside)	54 in (137 cm) wide, 43.5 in (110 cm) long, 11.5 in (29 cm) high
Ground Clearance	11 in (27.9 cm)
Min. Turning Radius	154 in (391.2 cm)
Engine	4-Stroke SOHC Twin Cylinder

## SPECIFICATIONS

<b>PRO XD CREW CAB</b>	
Displacement	999 cm <sup>3</sup>
Bore x Stroke	(93 mm) x (73.5 mm)
Stator Output	900 W @ 3000 RPM
Compression Ratio	10.5:1
Starting System	Electric
Fuel System	Electronic fuel injection
Ignition Timing	ECU Controlled 32° +/- 2° @ 5000 RPM
Spark Plug/ Gap	Autolite 5684 / 0.03 in (0.85 mm)
Front Suspension	Dual A-arm w/ 9 in (22.86 cm) of travel
Rear Suspension	Independent w/ 9 in (22.86 cm) of travel
Ignition System	Digital CDI
Lubrication System	Wet Sump
Driving System Type	PVT
Shift Type	Single Lever (H/L/N/R/P)
Gear Reduction - Low	Front 8.56:1/ Rear 25.59:1
Gear Reduction - Reverse	Front 7.67:1 / Rear 22.92:1
Gear Reduction - High	Front 4.03:1 / Rear 12.05:1
Drive Ratio - Front	42.11:1 (non-EPS) 42.13:1 (EPS)
Tire Size - Front	26 x 10 - 12
Tire Size - Rear	26 x 10 - 12
Tire Pressure - Front	10 psi (69 kPa)
Tire Pressure - Rear	20 psi (138 kPa)

## SPECIFICATIONS

<b>PRO XD CREW CAB</b>	
Brakes, Front/Rear	Foot Activated, 4 wheel hydraulic disc
Hood Headlight	2 single beam, 50W, quartz/halogen
Taillights	10 L.E.D. (.28W)
Brake Light	10 L.E.D. (3.1W)



# POLARIS PRODUCTS

## LUBRICANTS / SERVICE PRODUCTS

PRODUCT	SIZE (QUANTITY)	QUANTITY	PART NUMBER
Fogging Oil	12 fl oz (355 mL) aerosol	12	2870791
	1 qt (0.95 L)	12	2871517
PS-4	1 qt (0.95 L)	12	2876244
	2 qt (1.90 L)	8	2877490
	1 gal (3.8 L)	4	2876245
PS-4 Extreme Duty	1 qt (0.95 L)	12	2878920
	2 qt (1.90 L)	8	2878922
	1 gal (3.8 L)	4	2878919
AGL	1 qt (0.95 L)	12	2878068
	1 gal (3.8 L)	4	2878069
Pump for Gallon Jug	—	1	2870465
Demand Drive	1 qt (0.95 L)	12	2877922
	2.5 gal (9.5 L)	2	2877923
Antifreeze / Coolant	1 qt (0.95 L)	12	2880514
	1 gal (3.8 L)	6	2880513
Grease Gun Kit, Premium All Season	—	1	2871312
All Season Grease	Four 3 fl oz (89 mL) packs	6	2871322
	14 fl oz (414 mL) cartridge	1	2871423
Premium Starter Grease	—	1	2871460
U-Joint Grease	3 fl oz (89 mL) tube	24	2871515
	14 fl oz (414 mL) cartridge	1	2871551
Dielectric Grease (Nyogel®)	—	1	2871329
Carbon Clean	12 fl oz (355 mL) bottle	12	2871326
Fuel Stabilizer	16 fl oz (473 mL)	12	2870652

## POLARIS PRODUCTS

PRODUCT	SIZE (QUANTITY)	QUANTITY	PART NUMBER
	2.5 gal (9.5 L)	2	2872280
DOT 4 Brake Fluid	—	1	2872189
Loctite® 565 Thread Sealant	—	1	2871956
POLARIS Battery Tender Charger	—	1	2859044



# TROUBLESHOOTING

## DRIVE BELT WEAR/BURN

POSSIBLE CAUSE	SOLUTION
Driving onto a pickup or tall trailer in high range	Use low range during loading.
Starting out going up a steep incline	Use low range.
Driving at low RPM or ground speed – 3–7 mph (4.8–11.3 km/h)	Drive at a higher speed or use low range more frequently.
Insufficient warm-up at low ambient temperatures	Warm the engine at least 5 minutes. With the transmission in neutral, advance the throttle to about 1/8 throttle in short bursts, 5 to 7 times. The belt will become more flexible and prevent belt burning.
Slow/easy clutch engagement	Use the throttle quickly and effectively.
Towing/pushing at low RPM/low ground speed	Use low range only.
Utility use/plowing	Use low range only.
Stuck in mud or snow	Shift the transmission to low range and carefully use fast, aggressive throttle application to engage clutch. <b>WARNING: Excessive throttle may cause loss of control and vehicle rollover.</b>
Climbing over large objects from a stopped position	Shift the transmission to low range and carefully use fast, brief, aggressive throttle application to engage clutch. <b>WARNING: Excessive throttle may cause loss of control and vehicle rollover.</b>
Belt slippage from water or snow ingestion into the PVT system	Dry out the PVT. Prevent water from entering the PVT intake duct. See Intake Pre-Filters for more information. Inspect clutch seals for damage if repeated leaking occurs.
Clutch malfunction	An authorized dealer can assist.
Poor engine performance	Check for clogged air filter, clogged fuel filter, water in the fuel or foreign material in fuel tank or fuel lines. An authorized dealer can assist.
Slippage from failure to warm up belt	Always warm up the belt by operating below 30 mph (48 km/h) for 1 miles (1.6 km) (5 miles (8 km) or more when temperature is below freezing).
Wrong or missing belt	Install the recommended belt.
Improper break-in	Always break in a new belt and/or clutch.

## TROUBLESHOOTING

---

### ENGINE DOESN'T TURN OVER

POSSIBLE CAUSE	SOLUTION
Low battery voltage	Recharge the battery
Loose battery connections	Check all connections and tighten
Loose solenoid connections	Check all connections and tighten
Loose electronic control box connections	Inspect, clean, reinstall connectors

### ENGINE TURNS OVER, FAILS TO START

POSSIBLE CAUSE	SOLUTION
Out of fuel	Refuel
Water is present in fuel	Drain the fuel system and refuel
Old or non-recommended fuel	Replace with fresh recommended fuel
Fouled or defective spark plug	Inspect plug and replace if necessary
No spark to spark plug	Inspect plug and replace if necessary
Water or fuel in crankcase	Your authorized dealer can assist
Low battery voltage	Recharge the battery to 12.8 VDC
Mechanical failure	Your authorized dealer can assist

### ENGINE BACKFIRES

POSSIBLE CAUSE	SOLUTION
Weak spark from spark plug	Inspect, clean and/or replace spark plug
Incorrect spark plug gap or heat range	Set gap to specs or replace plug
Old or non-recommended fuel	Replace with fresh recommended fuel
Incorrectly installed spark plug wires	Your authorized dealer can assist
Mechanical failure	Your authorized dealer can assist
Loose ignition connections	Check all connections and tighten
Water present in fuel	Replace with fresh recommended fuel

## ENGINE PINGS OR KNOCKS

POSSIBLE CAUSE	SOLUTION
Poor quality or low octane fuel	Replace with recommended fuel
Incorrect spark plug gap or heat range	Set gap to specs or replace plug

## ENGINE RUNS IRREGULARLY, STALLS OR MISFIRES

POSSIBLE CAUSE	SOLUTION
Fouled or defective spark plug	Inspect, clean and/or replace spark plug
Worn or defective spark plug wires	Your authorized dealer can assist
Incorrect spark plug gap or heat range	Set gap to specs or replace plug
Loose ignition connections	Check all connections and tighten
Water present in fuel	Replace with new fuel
Low battery voltage	Recharge battery to 12.8 VDC
Incorrect fuel	Replace with recommended fuel
Clogged air filter	Inspect and clean or replace
Clogged intake pre-filter	Inspect and clean (with soapy water) or replace
Other mechanical failure	Your authorized dealer can assist

## TROUBLESHOOTING

---

### ENGINE STOPS OR LOSES POWER

POSSIBLE CAUSE	SOLUTION
Out of fuel	Refuel
Kinked or plugged fuel vent line	Inspect and replace
Water is present in fuel	Replace with new fuel
Fouled or defective spark plug	Inspect, clean and/or replace spark plug
Worn or defective spark plug wires	Your authorized dealer can assist
Incorrect spark plug gap or heat range	Set gap to specs or replace plug
Loose ignition connections	Check all connections and tighten
Low battery voltage	Recharge the battery to 12.8 VDC
Incorrect fuel	Replace with fresh recommended fuel
Clogged air filter	Inspect and clean or replace
Clogged intake pre-filter	Inspect and clean (with soapy water) or replace
Other mechanical failure	Your authorized dealer can assist
Overheated engine	Clean radiator screen and core, clean engine exterior. Your dealer can assist.
Plugged Spark Arrester	Clean out or replace
Low Coolant	Check coolant level

## WARRANTY

### LIMITED WARRANTY

POLARIS Inc., 2100 Highway 55, Medina, MN 55340 (POLARIS) gives a TWO YEAR LIMITED WARRANTY on all components of your POLARIS vehicle against defects in material or workmanship. POLARIS further warrants that the spark arrester in this product will meet the efficiency requirements of USFS standard 5100-1C for at least 1000 hours when subjected to normal use and when maintenance and installation are in accordance with POLARIS recommendations.

This warranty covers parts and labor charges for repair or replacement of defective parts and begins on the date of purchase by the original retail purchaser. This warranty is transferable to another owner during the warranty period through a POLARIS dealer, but any such transfer will not extend the original term of the warranty. The duration of this warranty may vary by international region based upon local laws and regulations.

### REGISTRATION

At the time of sale, the Warranty Registration Form must be completed by your dealer and submitted to POLARIS within ten days of purchase. Upon receipt of this registration, POLARIS will record the registration for warranty. No verification of registration will be sent to the purchaser as the copy of the Warranty Registration Form will be your proof of warranty coverage. If you have not signed the original registration and received the customer copy, please contact your dealer immediately. **NO WARRANTY COVERAGE WILL BE ALLOWED UNLESS YOUR VEHICLE IS REGISTERED WITH POLARIS.** Initial dealer preparation and set-up of your vehicle is very important in ensuring trouble-free operation. Purchasing a machine in the crate or without proper dealer set-up will void your warranty coverage.

### **WARRANTY COVERAGE AND EXCLUSIONS**

#### **LIMITATIONS OF WARRANTIES AND REMEDIES**

This POLARIS limited warranty excludes any failures that are not caused by a defect in material or workmanship. THIS WARRANTY DOES NOT COVER CLAIMS OF DEFECTIVE DESIGN. This warranty also does not cover acts of God, accidental damage, normal wear and tear, abuse or improper handling. This warranty also does not cover any vehicle, component, or part that has been altered structurally, modified, neglected, improperly maintained or used for racing, competition or purposes other than for which it was designed.

This warranty excludes damages or failures resulting from improper lubrication; improper engine timing; improper fuel; surface imperfections caused by external stress, heat, cold or contamination; operator error or abuse; improper component alignment, tension, adjustment or altitude compensation; snow, water, dirt or other foreign substance ingestion/contamination; improper maintenance; modified components; use of aftermarket or unapproved components, accessories, or attachments; use of unapproved software or calibration; unauthorized repairs; or repairs made after the warranty period expires or by an unauthorized repair center.

This warranty excludes damages or failures caused by abuse, accident, fire, or any other cause other than a defect in materials or workmanship and provides no coverage for consumable components, general wear items, or any parts exposed to friction surfaces, stresses, environmental conditions and/or contamination for which they were not designed or not intended, including but not limited to the following items:

- Wheels and tires
- Suspension components
- Brake components
- Seat components
- Clutches and components
- Steering components
- Batteries
- Light bulbs/Sealed beam lamps
- Filters
- Lubricants
- Bushings
- Finished and unfinished surfaces
- Carburetor/Throttle body components
- Engine components
- Drive belts
- Hydraulic components and fluids
- Circuit breakers/Fuses
- Electronic components
- Spark plugs
- Sealants
- Coolants
- Bearings

## LUBRICANTS AND FLUIDS

1. Mixing oil brands or using non-recommended oil may cause engine damage. We recommend the use of POLARIS engine oil.
2. Damage or failure resulting from the use of non-recommended lubricants or fluids is not covered by this warranty.

This warranty provides no coverage for personal loss or expense, including mileage, transportation costs, hotels, meals, shipping or handling fees, product pick-up or delivery, replacement rentals, loss of product use, loss of profits, or loss of vacation or personal time.

THE EXCLUSIVE REMEDY FOR BREACH OF THIS WARRANTY SHALL BE, AT POLARIS' OPTION, REPAIR OR REPLACEMENT OF ANY DEFECTIVE MATERIALS, COMPONENTS, OR PRODUCTS. THE REMEDIES SET FORTH IN THIS WARRANTY ARE THE ONLY REMEDIES AVAILABLE TO ANY PERSON FOR BREACH OF THIS WARRANTY. POLARIS SHALL HAVE NO LIABILITY TO ANY PERSON FOR INCIDENTAL, CONSEQUENTIAL OR SPECIAL DAMAGES OF ANY DESCRIPTION, WHETHER ARISING OUT OF EXPRESS OR IMPLIED WARRANTY OR ANY OTHER CONTRACT, NEGLIGENCE, OR OTHER TORT OR OTHERWISE. THIS EXCLUSION OF CONSEQUENTIAL, INCIDENTAL, AND SPECIAL DAMAGES IS INDEPENDENT FROM AND SHALL SURVIVE ANY FINDING THAT THE EXCLUSIVE REMEDY FAILED OF ITS ESSENTIAL PURPOSE.

THE IMPLIED WARRANTY OF FITNESS FOR A PARTICULAR PURPOSE IS EXCLUDED FROM THIS LIMITED WARRANTY. ALL OTHER IMPLIED WARRANTIES (INCLUDING BUT NOT LIMITED TO THE IMPLIED WARRANTY OF MERCHANTABILITY) ARE LIMITED IN DURATION TO THE ABOVE ONE YEAR WARRANTY PERIOD. POLARIS DISCLAIMS ALL EXPRESS WARRANTIES NOT STATED IN THIS WARRANTY. SOME STATES DO NOT PERMIT THE EXCLUSION OR LIMITATION OF INCIDENTAL OR CONSEQUENTIAL DAMAGES OR ALLOW LIMITATIONS ON THE DURATION OF IMPLIED WARRANTIES, SO THE ABOVE LIMITATIONS MAY NOT APPLY TO YOU IF INCONSISTENT WITH CONTROLLING STATE LAW.

## WARRANTY

---

### HOW TO OBTAIN WARRANTY SERVICE

If your vehicle requires warranty service, you must take it to a POLARIS Servicing Dealer. When requesting warranty service you must present your copy of the Warranty Registration Form to the dealer. (THE COST OF TRANSPORTATION TO AND FROM THE DEALER IS YOUR RESPONSIBILITY.) POLARIS suggests that you use your original selling dealer; however, you may use any POLARIS Servicing Dealer to perform warranty service.

### IN THE COUNTRY WHERE YOUR PRODUCT WAS PURCHASED:

Warranty or Service Bulletin repairs must be done by an authorized POLARIS dealer, or other qualified person. If you move or are traveling within the country where your product was purchased, Warranty and Service Bulletin repairs may be requested from any authorized POLARIS dealer, or other qualified person, that sells the same line as your product.

### OUTSIDE THE COUNTRY WHERE YOUR PRODUCT WAS PURCHASED:

If you are traveling temporarily outside the country where your product was purchased, you should take your product to an authorized POLARIS dealer, or other qualified person. You must show the dealer photo identification from the country of the selling dealer's authorized location as proof of residence. Upon residence verification, the servicing dealer will be authorized to perform the warranty repair.

### IF YOU MOVE:

If you move to another country, be sure to contact POLARIS Customer Assistance and the customs department of the destination country before you move. Product importation rules vary considerably from country to country. You may be required to present documentation of your move to POLARIS in order to continue your warranty coverage. You may also be required to obtain documentation from POLARIS in order to register your product in your new country. You should warranty register your product at a local POLARIS dealer in your new country immediately after you move to continue your warranty coverage and to ensure that you receive information and notices regarding your product.

### IF YOU PURCHASE FROM A PRIVATE PARTY:

If you purchase a POLARIS product from a private party, to be kept and used outside of the country in which the product was originally purchased, all warranty coverage will be denied. You must nonetheless register your product under your name and address with a local POLARIS dealer in your country to ensure that you receive safety information and notices regarding your product.



## EXPORTED PRODUCTS

EXCEPT WHERE SPECIFICALLY REQUIRED BY LAW, THERE IS NO WARRANTY OR SERVICE BULLETIN COVERAGE ON THIS PRODUCT IF IT IS SOLD OUTSIDE THE COUNTRY OF THE SELLING DEALER'S AUTHORIZED LOCATION. This policy does not apply to products that have received authorization for export from POLARIS. Dealers may not give authorization for export. You should consult an authorized dealer to determine this product's warranty or service coverage if you have any questions. This policy does not apply to products registered to government officials or military personnel on assignment outside the country of the selling dealer's authorized location. This policy does not apply to Safety Bulletins.

## NOTICE

If your product is registered outside of the country where it was purchased and you have not followed the procedure set above, your product will no longer be eligible for warranty or service bulletin coverage of any kind, other than safety recalls. Products registered to government officials or military personnel on assignment outside of the country where the product was purchased will continue to be covered by the Limited Warranty.

Please work with your dealer to resolve any warranty issues. Dealership contacts can be found via this website, if needed:

**[www.polaris.com/en-us/contact](http://www.polaris.com/en-us/contact)**

Should your dealer require any additional assistance, they will contact the appropriate person at POLARIS.

This warranty gives you specific legal rights, and you may also have other rights which vary from state to state or in different countries. If any of the above terms are void because of federal, state, local law, all other warranty terms will remain in effect.

### ***For questions call POLARIS Owner Connections:***

United States & Canada: 1-800-POLARIS (1-800-765-2747)

French: 1-800-268-6334

To report a safety defect to Transport Canada, you may either fill out an online defect complaint form at their website:

English: <http://www.tc.gc.ca/recalls>

French: <http://www.tc.gc.ca/rappels>

Or contact their Defect Investigations and Recalls Division by calling toll-free 1-800-333-0510 (Canada) or 819-994-3328 (Ottawa-Gatineau area / International).

## WARRANTY

---

### U.S.A. EPA EMISSIONS LIMITED WARRANTY

This emissions limited warranty is in addition to the POLARIS standard limited warranty for your vehicle. Polaris Industries Inc. warrants that at the time it is first purchased, this emissions-certified vehicle is designed, built and equipped so it conforms with applicable U.S. Environmental Protection Agency emission regulations. POLARIS warrants that the vehicle is free from defects in materials and workmanship that would cause it to fail to meet these regulations.

The warranty period for off road vehicles 100 cm<sup>3</sup> or greater emissions-certified vehicles starts on the date of purchase by original retail purchaser and continues for a period of 500 hours of engine operation, 3100 miles (5000 km) of vehicle travel, or 30 calendar months from the date of purchase, whichever comes first. The warranty period for ATVs less than 100 cm<sup>3</sup> emissions-certified vehicles starts on the date of purchase by original retail purchaser and continues for a period of 250 hours of engine operation, 1550 miles (2500 km) of vehicle travel, or 30 calendar months from the date of purchase, whichever comes first. This EPA emissions warranty period is extended for at least as long as the standard factory warranty that Polaris provides on the vehicle as a whole. The EPA emissions warranty period does not further extend if you purchase additional warranty coverage in the form of a service contract or other paid warranty extension, but emission-related parts may be covered subject to the terms of any such paid service contract or paid warranty extension.

This emissions limited warranty covers components whose failure increases the vehicle's regulated emissions, and it covers components of systems whose only purpose is to control emissions. Repairing or replacing other components not covered by this warranty is the responsibility of the vehicle owner. This emissions limited warranty does not cover components whose failure does not increase the vehicle's regulated emissions.

For exhaust emissions, emission-related components include any engine parts related to the following systems:

- Air-induction system
- Fuel system
- Ignition system
- Exhaust gas recirculation systems

The following parts are also considered emission-related components for exhaust emissions:

- Aftertreatment devices
- Crankcase ventilation valves
- Sensors
- Electronic control units

The following parts are considered emission-related components for evaporative emissions:

- Fuel Tank
- Fuel Cap
- Fuel Line
- Fuel Line Fittings
- Clamps\*
- Pressure Relief Valves\*
- Control Valves\*
- Control Solenoids\*
- Electronic Controls\*
- Vacuum Control Diaphragms\*
- Control Cables\*
- Control Linkages\*
- Purge Valves
- Vapor Hoses
- Liquid/Vapor Separator
- Carbon Canister
- Canister Mounting Brackets
- Carburetor Purge Port Connector

\*As related to the evaporative emission control system.

Emission-related components also include any other part whose only purpose is to reduce emissions or whose failure will increase emissions without significantly degrading engine/equipment performance. The exclusive remedy for breach of this limited warranty shall be, at the exclusive option of POLARIS, repair or replacement of any defective materials, components or products. THE REMEDIES SET FORTH IN THIS LIMITED WARRANTY ARE THE ONLY REMEDIES AVAILABLE TO ANY PERSON FOR BREACH OF THIS WARRANTY. POLARIS SHALL HAVE NO LIABILITY TO ANY PERSON FOR INCIDENTAL, CONSEQUENTIAL OR SPECIAL DAMAGES OF ANY DESCRIPTION, WHETHER ARISING OUT OF EXPRESS OR IMPLIED WARRANTY OR ANY OTHER CONTRACT, NEGLIGENCE OR OTHER TORT OR OTHERWISE. THIS EXCLUSION OF CONSEQUENTIAL, INCIDENTAL, AND SPECIAL DAMAGES IS INDEPENDENT FROM AND SHALL SURVIVE ANY FINDING THAT THE EXCLUSIVE REMEDY FAILED OF ITS ESSENTIAL PURPOSE.

ALL IMPLIED WARRANTIES (INCLUDING BUT NOT LIMITED TO ANY IMPLIED WARRANTIES OF MERCHANTABILITY AND FITNESS FOR A PARTICULAR PURPOSE) ARE LIMITED IN DURATION TO THE WARRANTY PERIOD DESCRIBED HEREIN. POLARIS DISCLAIMS ALL EXPRESS WARRANTIES NOT STATED IN THIS WARRANTY. Some states do not allow limitations on how long an implied warranty lasts, so the above limitation may not apply if it is inconsistent with the controlling state law.

This limited warranty excludes failures not caused by a defect in material or workmanship. This limited warranty does not cover damage due to accidents, abuse or improper handling, maintenance or use. This limited warranty also does not cover any engine that has been structurally altered, or when the vehicle has been used in racing competition. This limited warranty also does not cover physical damage, corrosion or defects caused by fire, explosions or other similar causes beyond the control of POLARIS.

## WARRANTY

---

Owners are responsible for performing the scheduled maintenance identified in the owner's manual. POLARIS may deny warranty claims for failures that have been caused by the owner's or operator's improper maintenance or use, by accidents for which POLARIS has no responsibility, or by acts of God.

Any qualified repair shop or person may maintain, replace, or repair the emission control devices or systems on your vehicle. An authorized POLARIS dealer, or other qualified person, can perform any service that may be necessary for your vehicle. POLARIS also recommends POLARIS parts, however equivalent parts may be used for such service. It is a potential violation of the Clean Air Act if a part supplied by an aftermarket parts manufacturer reduces the effectiveness of the vehicle's emission controls. Tampering with emission controls is prohibited by federal law.

## CALIFORNIA RESIDENTS

Certain POLARIS Off-Road Vehicles are available in 49-state and 50-state versions. Only the 50-state models are certified for sale in California. The 50-state models available for sale in California are identified by the letter "B" in the ninth position of the model number (e.g., R16RTE87B). The POLARIS 50-state models are designed and built with features such as a reduced cargo box capacity. Any modifications to these features may be a violation of the applicable California regulations and may void this limited emissions warranty offered by the manufacturer.

The California evaporative emissions control system limited warranty statement below applies to your Off Highway Recreational Vehicle in California if the vehicle is equipped with an evaporative emission control system and is labeled with a Vehicle Evaporative Emissions Control Information label indicating that the vehicle conforms to California evaporative emissions regulations applicable to new off-road sport vehicles, all-terrain vehicles, or off-road utility vehicles. These vehicles are referred to as "OHRV-EVAP" below.

### **CALIFORNIA EMISSION CONTROL WARRANTY STATEMENT YOUR WARRANTY RIGHTS AND OBLIGATIONS**

The California Air Resources Board and Polaris Industries Inc. are pleased to explain the emission control system warranty on your model year 2018 and newer Off Highway Recreational Vehicle. In California, new off-highway recreational vehicles must be designed, built and equipped to meet the State's stringent anti-smog standards. Polaris must warrant the emission control system on your OHRV-EVAP for the periods of time listed below provided there has been no abuse, neglect or improper maintenance of your OHRV-EVAP.

Your emission control system may include parts such as the carburetor or fuel injection system, fuel tank, fuel hoses, carbon canister, engine computer and Evaporative Emissions Control System parts listed in the U.S.A. EPA Emissions Limited Warranty. Also included may be hoses, belts, connectors and other emission-related assemblies. Where a warrantable condition exists, Polaris will repair your OHRV-EVAP at no cost to you including diagnosis, parts and labor.

---

## **MANUFACTURER'S WARRANTY COVERAGE:**

For model year 2018 and newer OHRV-EVAP models.

For 30 months, or 2500 miles (4023 km), or 250 hours, whichever comes first, except for evaporative components over the OHRV high-priced warranty value, which is covered for 60 months, or 5000 miles (8047 km), or 500 hours, whichever comes first.

If any emission-related part on your OHRV-EVAP is defective, the part will be repaired or replaced by Polaris.

### **OWNER'S WARRANTY RESPONSIBILITIES:**

As the OHRV-EVAP owner, you are responsible for the performance of the required maintenance listed in your owner's manual. Polaris recommends that you retain all receipts covering maintenance on your OHRV-EVAP, but Polaris cannot deny warranty solely for the lack of receipts or for your failure to ensure the performance of a scheduled maintenance.

As an owner you are responsible for presenting your OHRV-EVAP to a Polaris dealer as soon as a problem exists. The warranty repairs should be completed in a reasonable amount of time, not to exceed 30 days.

As an OHRV-EVAP owner, you should also be aware that Polaris may deny you warranty coverage if your OHRV-EVAP or a part has failed due to abuse, neglect, improper maintenance or unapproved modifications.

## **ADD-ON OR MODIFIED PARTS**

An add-on or modified part must be compliant with applicable CARB emission control standards. A violation of this requirement is punishable by civil and/or criminal punishment.

If you have any questions regarding your warranty rights and responsibilities, you should contact Polaris Customer Assistance at 1-800-POLARIS (1-800-765-2747) or the California Air Resources Board at 9528 Telstar Avenue, El Monte, CA 91731.

United States & Canada: 1-800-POLARIS (1-800-765-2747)

French: 1-800-268-6334



---

# MAINTENANCE LOG

## MAINTENANCE LOG

Use the following chart to record periodic maintenance.

DATE	MILES (KM) OR HOURS	TECHNICIAN	SERVICE PERFORMED / COMMENTS





<b>A</b>		Clutch Cover Warning..... 17	
Adding or Changing Coolant .....	115	Cold Weather Operation..... 69	
Adjustable Speed Limiting .....	56	Component Locations..... 31	
Adjustable Steering Wheel .....	33	Console..... 32	
Age Restrictions .....	21	Cooling System..... 115	
Air Filter / Air Box.....	144	Crankcase Emission Control System .....	95
Air Filter Inspection .....	126	Crossing Hillside..... 24	
Air Filter Replacement .....	126		
Air Intake Inspection.....	128		
Alarm			
Belt Spin.....	39		
Reverse Alert Beeper (if equipped).....	34		
All Wheel Drive/Rear			
Differential System .....	71		
Auxiliary Outlet.....	33		
AWD.....	36		
Axle and Wheel Nut Torque			
Specifications.....	135		
Axle Inspection .....	133		
<b>B</b>			
Battery .....	139		
Battery Charging .....	141		
Battery Installation .....	140		
Battery Removal.....	140		
Battery Storage.....	140		
Battery Trickle-Charging Outlet.....	33		
Belt Inspection .....	121		
Belt Installation .....	122		
Belt Removal .....	120		
Belt Spin Alarm .....	39		
Brake Lights .....	138		
Brake Pedal .....	37		
Brake System Break-in .....	66		
Brakes .....	130		
Braking .....	70		
Break-in Period .....	65		
Break-In Period.....	98		
<b>C</b>			
California Residents.....	170		
Clean the Exterior.....	144		
		<b>D</b>	
		Demand Change Oil Change .....	111
		Descending Hills Improperly .....	24
		Diagnostic Display Code	
		Definitions .....	60
		Drive Belt Wear/Burn.....	159
		Driveline Mode Switch .....	36
		Driving Downhill .....	76
		Driving in Reverse .....	78
		Driving on a Sidehill .....	76
		Driving on Slippery Surfaces .....	75
		Driving Over Obstacles .....	78
		Driving Procedures .....	74
		Driving Through Water.....	77
		Driving Uphill .....	75
		Driving with a Passenger.....	74
		Dumping the Cargo Box.....	82
			<b>E</b>
		Electromagnetic Interference .....	95
		Electronic Power Steering .....	39
		Emissions Limited Warranty.....	168
		Engine and Drivetrain Break-in .....	65
		Engine Backfires .....	160
		Engine Breather Inspection.....	128
		Engine Doesn't Turn Over .....	160
		Engine Oil.....	105
		Engine Oil and Filter	
		Replacement .....	107
		Engine Pings or Knocks .....	161
		Engine Runs Irregularly, Stalls or Misfires .....	161
		Engine Stops or Loses Power ....	162
		Engine Turns Over, Fails to Start.....	160

---

Exhaust Emission Control System .....	95
Exported Products .....	167
Exposure to Exhaust .....	28

## F

Failure to Inspect Before Operating .....	22
Fan, Cooling .....	115
Fluid Levels .....	144
Fluid Part Numbers .....	157
Fuel Cap .....	39
Fuel Leak Inspection .....	118
Fuel Transport Warning .....	15
Fuses .....	139

## G

Gear Selector .....	34
Gearcase Specification Chart .....	109

## H

Hauling Cargo .....	80
Headlight Beam Adjustment .....	138
Headlights	
Bulb Replacement .....	136
Heater Control Panel (if equipped) .....	36
Helmet .....	11
Hood Latches .....	40
Hot Exhaust Systems .....	28
How To Obtain Warranty Service .....	166

## I

Ignition Switch .....	35
Improper Cargo Loading .....	27
Improper Tire Maintenance .....	23
Inspect and Lubricate .....	145
Instrument Cluster	
Adjustable Speed Limiting .....	56

Back Light Color .....	53
Back Light Level .....	54
Clock .....	51
Diagnostic Code .....	59
Display Area 1 .....	45
Display Area 2 .....	46
Indicator Lamps .....	43
Options Menu .....	48
Overview .....	42
Service Hours .....	55
Unit Selection Distance .....	49
Unit Selection Temperature .....	50

## L

Light Switch .....	35
Lights .....	136
Limited Warranty .....	163
Load Capacity .....	80
Load/Passenger/Tire Pressure Warning .....	16
Low Gear Usage .....	34
Lubricants / Service Products .....	157
Lubrication Recommendations ...	104

## M

Maintenance	
Grease Lubrication Points .....	111
Overview .....	97
Shift Cable / Linkage	
Inspection .....	124
Steering Inspection .....	131
Wheel Bearing Inspection .....	132
Maintenance Log .....	173
Maximum Speed Setting .....	56
Modifications to Vehicle .....	29

## N

Noise Emission Control System .....	95
Notice .....	167

---

## O

Obstacles .....	78
Occupant Protection Structure (OPS).....	40
Oil and Filter .....	144
Oil Check.....	105
Oil Recommendations .....	105
Operating Improperly in Reverse...	25
Operating Over Obstacles .....	26
Operating Through Water .....	26
Operating With a Load on the Vehicle .....	23
Operating Without Instruction .....	21
Operation on Public Lands in the U.S.A.....	95
Outlets .....	32-33
Overflow Bottle Coolant Level .....	117

## P

Parking on an Incline .....	79
Parking the Vehicle .....	79
Part Numbers .....	157
Payload Warning .....	15
Periodic Maintenance Overview .....	97
Personal Protective Equipment.....	11
Plugs, Spark .....	113
Polaris Products .....	157
POLARIS Variable Transmission (PVT) Drying .....	124
POLARIS Variable Transmission System.....	119
Polishing the Vehicle .....	144
Poor Visibility .....	27
Power Steering Unit (Cleaning)...	136
Pre-Ride Inspection .....	67
Proper Use Warning (2-seat).....	14
Proper Use Warning (4-seat).....	14
Pulse Bar.....	37
PVT Break-in (Clutches/Belt) .....	66

## R

Radiator and Cooling Fan.....	115
-------------------------------	-----

Radiator Coolant Level .....	116
Rear Differential System .....	71
Registration, Warranty .....	163
Removal from Storage.....	145
Reverse Alert Beeper (if equipped).....	34
Reverse Operation.....	78

## S

Safe Operation Practices .....	66
Safety Labels Clutch Cover Warning.....	17
Seat Belt / Drive Responsibly Warning .....	12
Safety Labels and Locations .....	12
Safety Symbols .....	8
Safety Warnings Using Alcohol or Drugs .....	22
Safety, Winch Maintenance.....	94
Seat and Storage Compartments .....	38
Seat Belt / Drive Responsibly Warning .....	12
Seat Belts .....	22, 41
Shift Caution.....	18
Shock Loading the Winch .....	93
Signal Words .....	8
Spark Arrester .....	129
Spark Plug Gap/Torque.....	113
Spark Plug Inspection.....	113
Spark Plug Recommendations .....	113
Specifications Crew Cab .....	153
Standard Cab .....	151
Spring Adjustment .....	134
Stalling While Climbing a Hill.....	25
Starting the Engine .....	69
Steering Wheel Adjustment .....	33
Stopping the Engine.....	69
Storage .....	144
Storage Area .....	145
Switches Light Switch.....	35

---

## T

Throttle Pedal .....	38
Tire Rotation .....	135
Tire Tread Depth .....	134
Tires .....	134
Towing Loads .....	81
Trailer Hitch Bracket .....	38
Trailer/Hitch Capacity .....	18
Transmission Oil Change .....	110
Transmission Oil Check .....	109
Transporting the Vehicle .....	147
Turning Improperly .....	24

Winch Maintenance and Service Safety .....	94
Winch Shock Loading .....	93

## U

Unauthorized Use of the Vehicle ...	28
USB Outlets .....	32

## V

Vehicle Identification Numbers .....	9
Vehicle Immersion .....	125
Vehicle Tie-Down	
Loading and unloading .....	145
Minimum Working Load Limit (WLL) .....	145
Tie Down Locations .....	149

## W

Warning Symbols .....	8
Warranty Coverage And Exclusions	
Lubricants and Fluids .....	165
Washing the Vehicle .....	143
Welcome Page .....	3
Wet Fouled Plug .....	114
Wheel Installation .....	136
Wheel Removal .....	135
Wheel, Steering	
Adjustment .....	33
Winch	
Winch Operation .....	87
Winch Safety Precautions .....	85
Winch Cable Care .....	92





For your nearest Polaris dealer,  
call 1-800-POLARIS (765-2747)  
or visit [www.polaris.com](http://www.polaris.com)

Polaris, Inc.  
2100 Highway 55  
Medina, MN 55340



Part No. 9940401 Rev 02  
Printed in USA