



## Boma Braai

- FREE STANDING BRAAI -

Another first in South Africa, the Chad-O-Chef Boma Braai suavely combines contemporary European design, and advanced material knowledge, adding a juicy spin to your entertainment cooking methods.

The large central aperture allows you to add wood to the fire while cooking, so you can carry on the festivities uninterrupted. The Boma Braai's 8mm thick cooking surface retains and spreads heat evenly, searing steak and chops quickly and locking in moisture.

Make every stir-fry a spectacle from all angles around the Boma Braai and get your guests involved in the cooking action.

- Corten Steel or Mild Steel design
- Large Central Aperture for adding wood whilst cooking
- Various Accessories available
- Large storage area for wood and fire-lighters



SAFETY, STYLE & QUALITY THAT LASTS

**CHAD-O-CHEF**  
Lifestyle products

Since 1983



# Boma Braai

- FREE STANDING BRAAI -

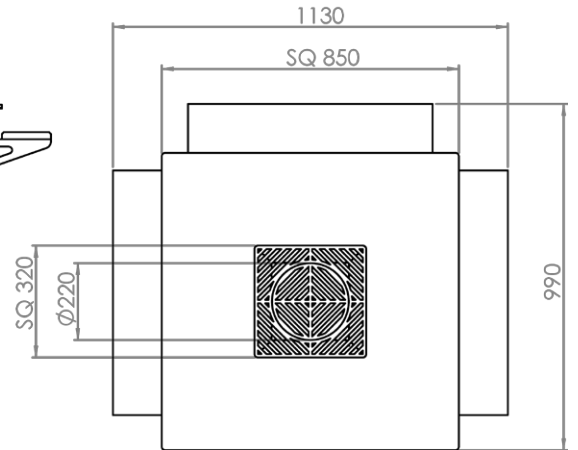
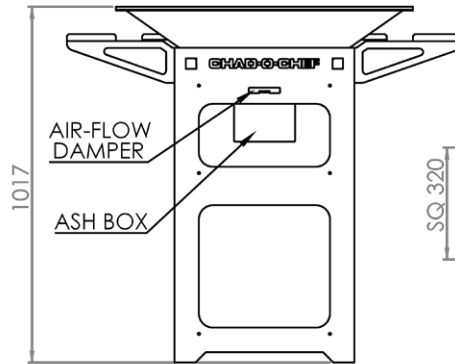
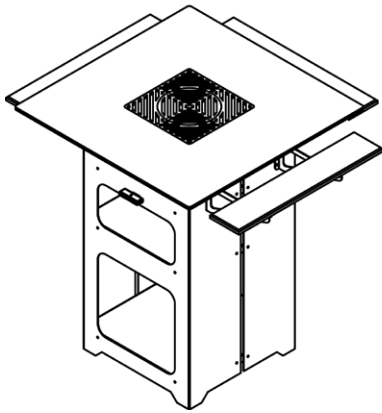

## FINISH OPTIONS



Corten Steel (Rustic)

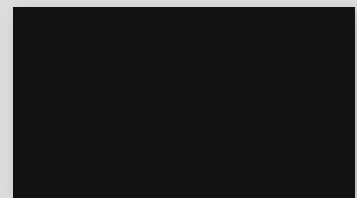

Mild Steel (Black)

## INSTALLATION INSTRUCTIONS

The Boma Braai is a free standing unit, designed to be loosely retrofitted into place in your outdoor braai area.

Take care to ensure your Boma Braai is placed on a flat surface in order for the curved cooking surface to shrug excess fat and oils into the fire as designed.

The Corten Steel option takes time to oxidise naturally to the desired rustic effect, and is safe for coastal use as well, due to the material's ability to resist the penetration of rust.



**CHAD-O ENGINEERING**  
T: 011 668 1910/1 | F: 086 612 5431  
retail@chad-o-chef.co.za | www.chad-o-chef.co.za

