

# MAKE YOUR OWN PAPER DRAGONFLY ACTIVITY SHEET

from

## **A Life Made by Hand: The Story of Ruth Asawa**

Written and illustrated by Andrea D'Aquino

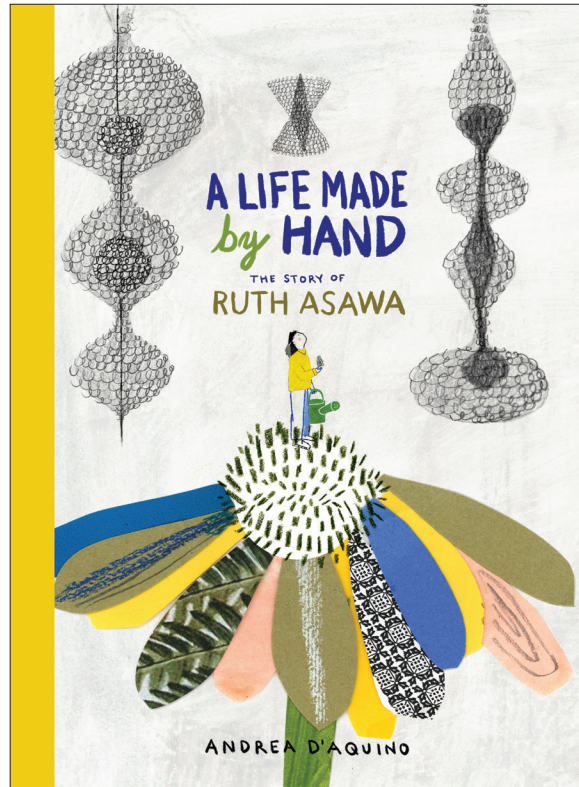

**A selection of the  
Junior Library Guild**

*A Life Made by Hand* tells the story of a pioneering Japanese American artist whose work is collected in major museums around the world. Inspired by the world around her, Asawa saw beauty in the ordinary: the webs of spiders, wings of insects, and drops of water found in the garden on the farm where she spent her childhood. “An artist,” she said, “is an ordinary person who can take ordinary things and make them special.”

---

**FALL 2019**

ISBN: 978-1-61689-836-6



**Princeton Architectural Press**  
*www.papress.com*

# MAKE YOUR OWN PAPER DRAGONFLY ACTIVITY SHEET

Ruth Asawa was a teacher, and knew that the best way to learn is to use your hands.

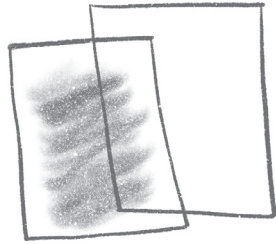

**1** Choose 2 sheets of paper in different colors and glue them back to back.

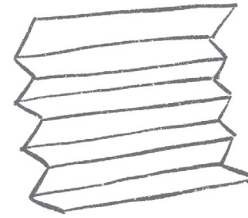

**2** When dry, fold accordion-style. This one is folded 7 times.

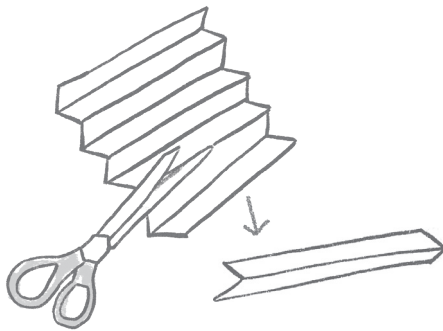

**3** Cut off the bottom section to make a small strip with just 1 crease in it.

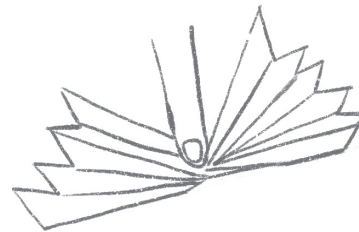

**4** Flatten the folds to make wings. Press down on the center and spread out each side.



**5** Fold the small strip in half to make the insect body.

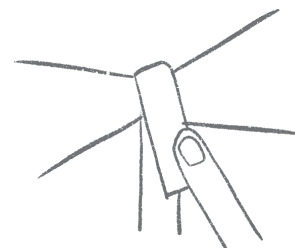

**6** Wrap the body around the wings and glue or tape it down. Draw a face on it, or whatever else you think of.

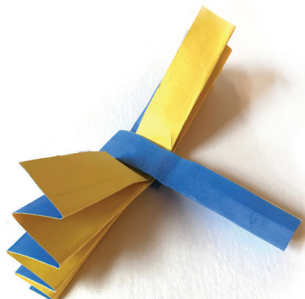

You did it!  
It's okay if yours looks different.  
That's what makes each one special.