

**FW**  
**P4.10**



IS88 Rev.18 15/11/2021

# CTRL

## centrale di comando per barriere elettromeccaniche

Istruzioni originali

**ROGER**  
BRUSHLESS



- IT - Istruzioni ed avvertenze per l'installatore
- EN - Instructions and warnings for the installer
- DE - Anweisungen und Hinweise für den Installateur
- FR - Instructions et consignes pour l'installateur
- ES - Instrucciones y advertencias para el instalador
- PT - Instruções e advertências para o instalador
- NLD - Aanwijzingen en waarschuwingen voor de installateur
- PL - Instrukcja i ostrzeżenia dla instalatora

**ROGER**  
TECHNOLOGY



# INDICE • INDEX • INDEX • INDEXER • ÍNDICE • ÍNDICE • INDEX • INDEKS

## ITALIANO

1	Avvertenze generali	28
	Dichiarazione CE di Conformità	30
2	Simbologia	31
3	Descrizione prodotto	31
4	Aggiornamenti versione P4.10	32
5	Caratteristiche tecniche prodotto	32
6	Descrizione dei collegamenti	33
6.1	Installazione tipo	33
6.2	Collegamenti elettrici	34
7	Comandi e accessori	35
8	Tasti funzione e display	38
9	Accensione o messa in servizio	38
10	Modalità funzionamento display	38
10.1	Modalità visualizzazione dei parametri	38
10.2	Modalità visualizzazione di stato comandi e sicurezze	39
10.3	Modalità TEST	39
10.4	Modalità Stand By	39
11	Apprendimento della corsa	40
11.1	Prima di procedere	40
11.2	Procedura di apprendimento STANDARD	41
11.3	Procedura di apprendimento MASTER/SLAVE	41
12	Indice dei parametri	45
13	Menù parametri	47
14	Esempi di applicazioni per il funzionamento in modalità accesso parcheggi	55
15	Segnalazione degli ingressi di sicurezza e dei comandi (modalità TEST)	56
16	Segnalazione allarmi e anomalie	57
17	Diagnostica - Modalità INFO	60
18	Sblocco meccanico	61
19	Collaudo	61
20	Messa in funzione	62
21	Manutenzione	62
22	Smaltimento	62
23	Informazioni aggiuntive e contatti	62

## ENGLISH

1	General safety precautions	63
	Declaration CE of Conformity	65
2	Symbols	66
3	Product description	66
4	Updates of version P4.10	67
5	Technical characteristics of product	67
6	Description of connections	68
6.1	Typical installation	68
6.2	Electrical connections	69
7	Commands and Accessories	70
8	Function buttons and display	73
9	Switching on or commissioning	73
10	Display function modes	73
10.1	Parameter display mode	73
10.2	Command and safety device status display mode	74
10.3	TEST mode	74
10.4	Standby mode	74
11	Travel acquisition	75
11.1	Before starting	75
11.2	STANDARD acquisition procedure	76
11.3	MASTER/SLAVE acquisition procedure	77
12	Index of parameters	80
13	Parameters menu	82
14	Examples of applications in parking access mode	90
15	Safety input and command status (TEST mode)	91
16	Alarms and faults	92
17	Procedural verifications - INFO Mode	95
18	Mechanical release	96
19	Initial testing	96
20	Start-up	97
21	Maintenance	97
22	Disposal	97
23	Additional information and contact details	97

## DEUTSCH

1	Allgemeine Sicherheitshinweise	98
	Konformitätserklärung	100
2	Symbole	101
3	Produktbeschreibung	101
4	Aktualisierungen Version P4.10	102
5	Technische Daten des Produkts	102
6	Beschreibung der Anschlüsse	103
6.1	Art der Installation	103
6.2	Elektrische Anschlüsse	104
7	Befehle und Zubehör	105
8	Funktionstasten und Display	108
9	Einschalten oder Inbetriebnahme	108
10	Funktion Display	108
10.1	Parameter-Anzeigemodus	108
10.2	Anzeige des Status von Befehlen und Sicherheitseinrichtungen	109
10.3	TEST-Modus	109
10.4	Standby-Modus	109
11	Lernlauf	110
11.1	Zunächst	110
11.2	Lernlauf STANDARD	111
11.3	Lernlauf MASTER/SLAVE	112
12	Verzeichnis der Parameter	115
13	Menü Parameter	117
14	Anwendungsbeispiele für Zugangsarten zu den Parkplätzen	125
15	Meldung von Sicherheitseingängen und Befehlen (TEST-Modus)	126
16	Meldung von Alarmen und Störungen	127
17	Diagnostik - Betriebsart Info	130
18	Mechanische Entriegelung	131
19	Abnahmeprüfung	131
20	Inbetriebnahme	132
21	Wartungsarbeiten	132
22	Entsorgung	132
23	Zusätzliche Informationen und Kontakte	132

## FRANÇAIS

1	Consignes générales de sécurité	133
	Déclaration de conformité CE	135
2	Symboles	136
3	Description produit	136
4	Mises à jour version P4.10	137
5	Caractéristiques techniques produit	137
6	Description des raccordements	138
6.1	Installation type	138
6.2	Raccordements électriques	139
7	Commandes et accessoires	140
8	Touches fonction et écran	143
9	Allumage ou mise en service	143
10	Modalités fonctionnement écran	143
10.1	Modalités affichage des paramètres	143
10.2	Modalité d'affichage d'état commandes et sécurités	144
10.3	Modalité TEST	144
10.4	Modalité Stand By	144
11	Apprentissage de la course	145
11.1	Avant de procéder	145
11.2	Procédure d'apprentissage STANDARD	146
11.3	Procédure d'apprentissage MASTER/SLAVE	147
12	Index des paramètres	150
13	Menu paramètres	152
14	Ex. d'applications pour le fonctionnement en modalité accès parkings	160
15	Signalisation des entrées de sécurité et des commandes (mod. TEST)	161
16	Signalisations alarmes et anomalies	161
17	Diagnostic - Modalité info	165
18	Déblocage mécanique	166
19	Test	166
20	Mise en marche	167
21	Entretien	167
22	Élimination	167
23	Informations complémentaires et contacts	167

## ESPAÑOL

1	Advertencias generales	168
	Declaración CE de Conformidad	170
2	Símbolos	171
3	Descripción del producto	171
4	Actualización de la versión P4.10	172
5	Características técnicas del producto	172
6	Descripción de las conexiones	173
6.1	Instalación básica	173
6.2	Conexiones eléctricas	174
7	Comandos y accesorios	175
8	Teclas de función y pantalla	178
9	Encendido o puesta en servicio	178
10	Modo de funcionamiento de la pantalla	178
10.1	Modos de visualización de los parámetros	178
10.2	Modos de visualización de indicaciones de seguridad y comandos	179
10.3	Modo de TEST	179
10.4	Modo Stand By	179
11	Aprendizaje del recorrido	180
11.1	Antes de actuar	180
11.2	Procedimiento de aprendizaje STANDARD	181
11.3	Procedimiento de aprendizaje MASTER/SLAVE	182
12	Índice de los parámetros	185
13	Menú de parámetros	187
14	Ejemplos de aplicaciones para funcionamiento en modo de acceso a los aparcamientos	195
15	Señalización de las entradas de seguridad y de los comandos (mod. TEST)	196
16	Señalización de alarmas y anomalías	197
17	Diagnostica - Modo INFO	200
18	Desbloqueo mecánico	201
19	Ensayo	201
20	Puesta en funcionamiento	202
21	Mantenimiento	202
22	Eliminación	202
23	Información adicional y contactos	202

## PORTUGUÊS

1	Advertências gerais	203
	Declaração CE de conformidade	205
2	Simbologia	206
3	Descrição do produto	206
4	Atualizações da versão P4.10	207
5	Caraterísticas técnicas do produto	207
6	Descrição das ligações	208
6.1	Instalação tipo	208
6.2	Ligações eléctricas	209
7	Comandos e acessórios	210
8	Teclas de função e display	213
9	Ignição ou comissionamento	213
10	Modalidade de funcionamento do display	213
10.1	Modalidade de visualização dos parâmetros	213
10.2	Modalidade de visualização de estado dos comandos e dispositivos de segurança	214
10.3	Modalidade TESTE	214
10.4	Modalidade Stand By	214
11	Aprendizagem do curso	215
11.1	Antes de proceder	215
11.2	Procedimento de aprendizado STANDARD	216
11.3	Procedimento de aprendizado MASTER/SLAVE	217
12	Índice dos parâmetros	220
13	Menu dos parâmetros	222
14	Exemplos de aplicações para o funcionamento em modo de acesso aos estacionamentoos	230
15	Sinalização das entradas de segurança e dos comandos (modalidade TEST)	231
16	Sinalização de alarmes e anomalias	232
17	Diagnosticar - Modo INFO	235
18	Desbloqueio mecânico	236
19	Teste	236
20	Entrada em funcionamento	237
21	Manutenção	237
22	Descarte	237
23	Informações adicionais e contatos	237

## DUTCH

1	Algemene waarschuwingen	238
	EG-verklaring van overeenstemming	240
2	Symbolen	241
3	Beschrijving product	241
4	Update versie P4.10	242
5	Technische kenmerken product	242
6	Beschrijving aansluitingen	243
6.1	Type installatie	243
6.2	Elektrische aansluitingen	244
7	Bedieningen en accessoires	245
8	Funcietoetsen en display	248
9	Inschakeling en inbedrijfsstelling	248
10	Bedrijfsmodus display	248
10.1	Modus van weergave parameters	248
10.2	Modus van weergave van de status bedieningen en veiligheden	249
10.3	TEST modus	249
10.4	Stand By modus	249
11	Lering van de slag	250
11.1	Voordat de handelingen worden uitgevoerd	250
11.2	Procedure van lering STANDARD	251
11.3	Procedure van lering MASTER/SLAVE	252
12	Inhoudsopgave van de parameters	255
13	Menu parameters	257
14	Voorbeelden van toepassingen voor de werking in de toegangsmodaliteit parkings	265
15	Signalering van de veiligheidsingangen en van de bedieningen (mod. TEST)	266
16	Signalering alarmen en storingen	267
17	Modus INFO	270
18	Mechanische deblokkering	271
19	Test	271
20	Inbedrijfstelling	272
21	Onderhoud	272
22	Inzameling	272
23	Bijkomende informatie en contact	272

## POLSKI

1	Ostrzeżenia ogólne	273
	Deklaracja zgodności WE	275
2	Symbola	276
3	Opis urządzenia	276
4	Aktualizacja wersji P4.10	277
5	Charakterystyka techniczna urządzenia	277
6	Opis połączeń	278
6.1	Rodzaj instalacji	278
6.2	Połączenia elektryczne	279
7	Elementy sterownicze i akcesoria	280
8	Przyciski funkcyjne i wyświetlacz	283
9	Włączanie lub uruchamianie	283
10	Tryby działania wyświetlacza	283
10.1	Wyświetlanie parametrów	283
10.2	Wyświetlanie statusu sygnałów sterowniczych i zabezpieczeń	284
10.3	Tryb TEST	284
10.4	Tryb Stand By	284
11	Programowanie ruchu	285
11.1	Wcześniej	285
11.2	Procedura programowania ruchu STANDARD	286
11.3	Procedura programowania ruchu MASTER/SLAVE	287
12	Spis parametrów	290
13	Spis parametrów	292
14	Przykłady zastosowań dla działania w trybie wjazdu na parkingi	301
15	Sygnalizacja wejść bezpieczeństwa i sygnałów sterowniczych (tryb TEST)	302
16	Sygnalizacja alarmowe i błędy	303
17	Tryb INFO	305
18	Odblokowanie mechaniczne	307
19	Testy odbiorcze	307
20	Uruchomienie	308
21	Konserwacja	308
22	Utylizacja	308
23	Informacje dodatkowe i dane kontaktowe	308

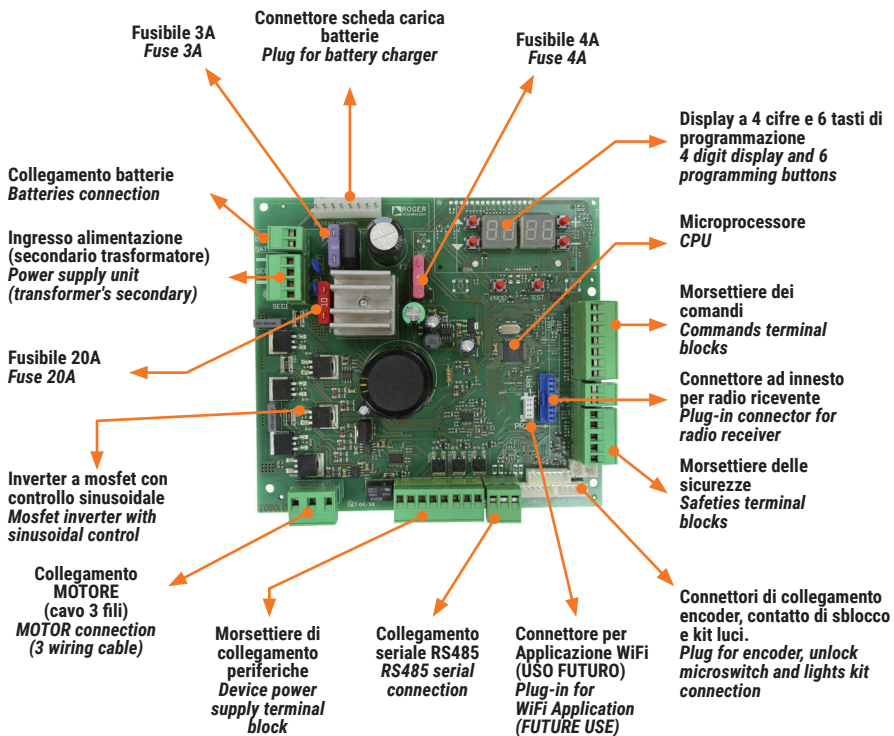

1

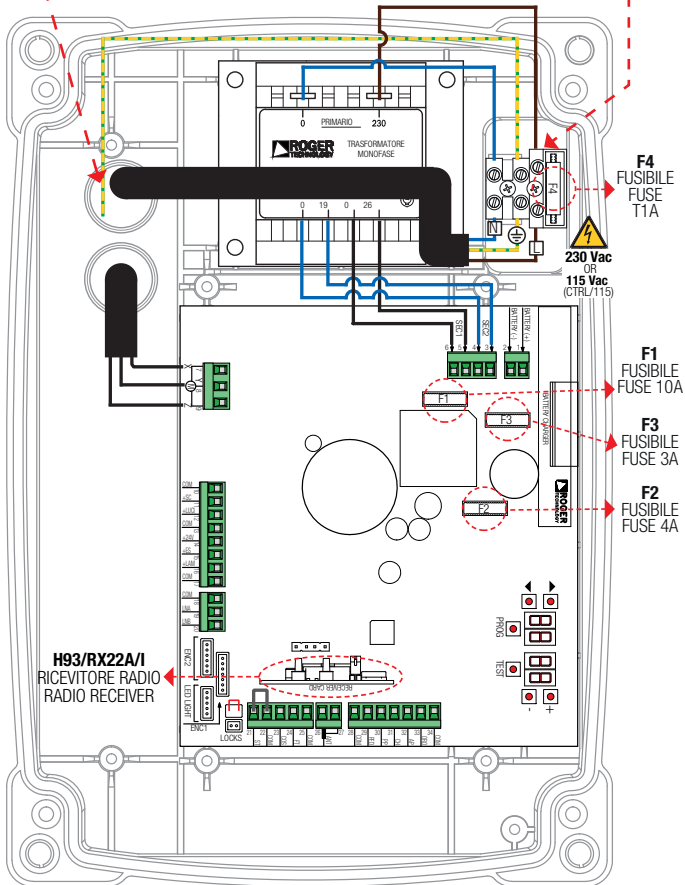
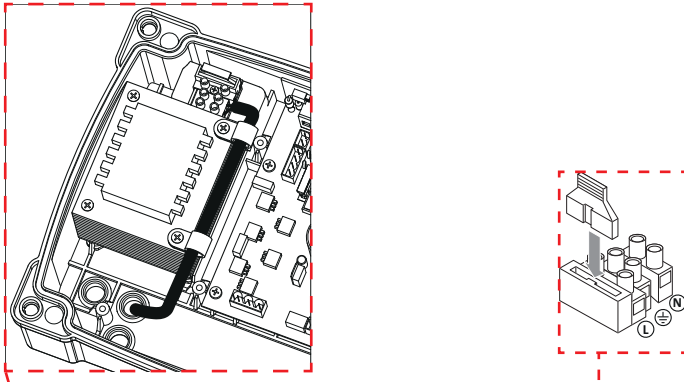

# BIONIK

2

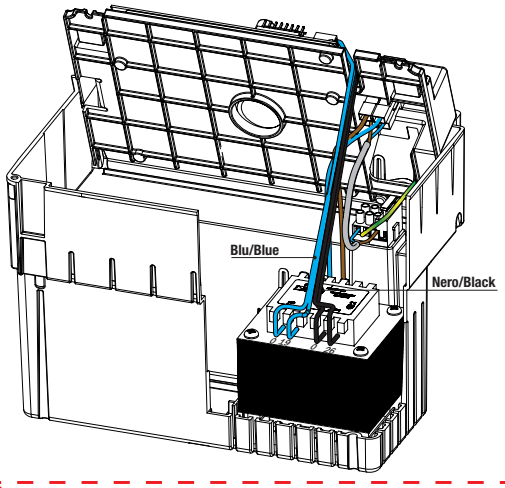

F1 FUSIBILE FUSE 10A  
F3 FUSIBILE FUSE 3A  
F2 FUSIBILE FUSE 4A

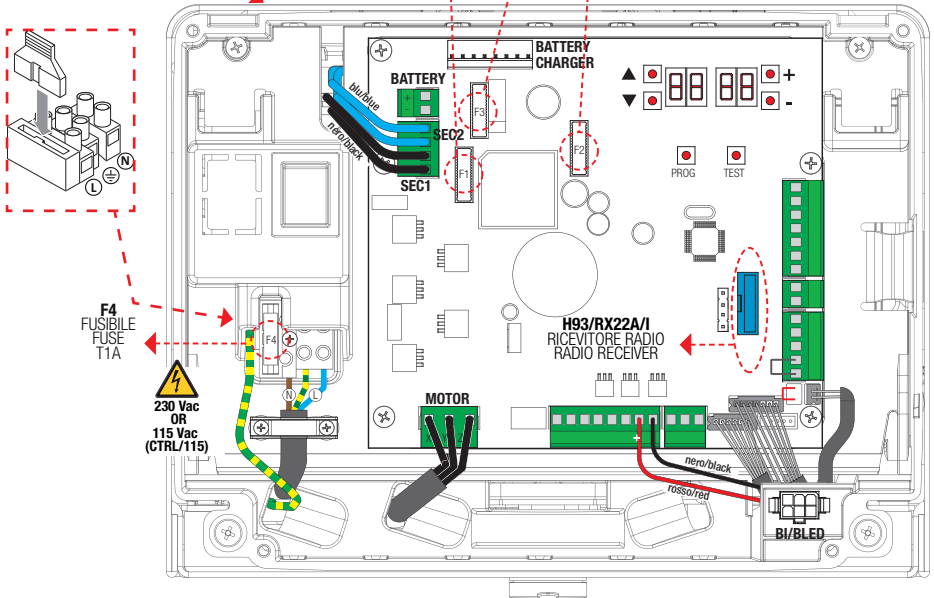

F4 FUSIBILE FUSE 11A

⚡  
230 Vac  
OR  
115 Vac  
(CTRL/115)

3

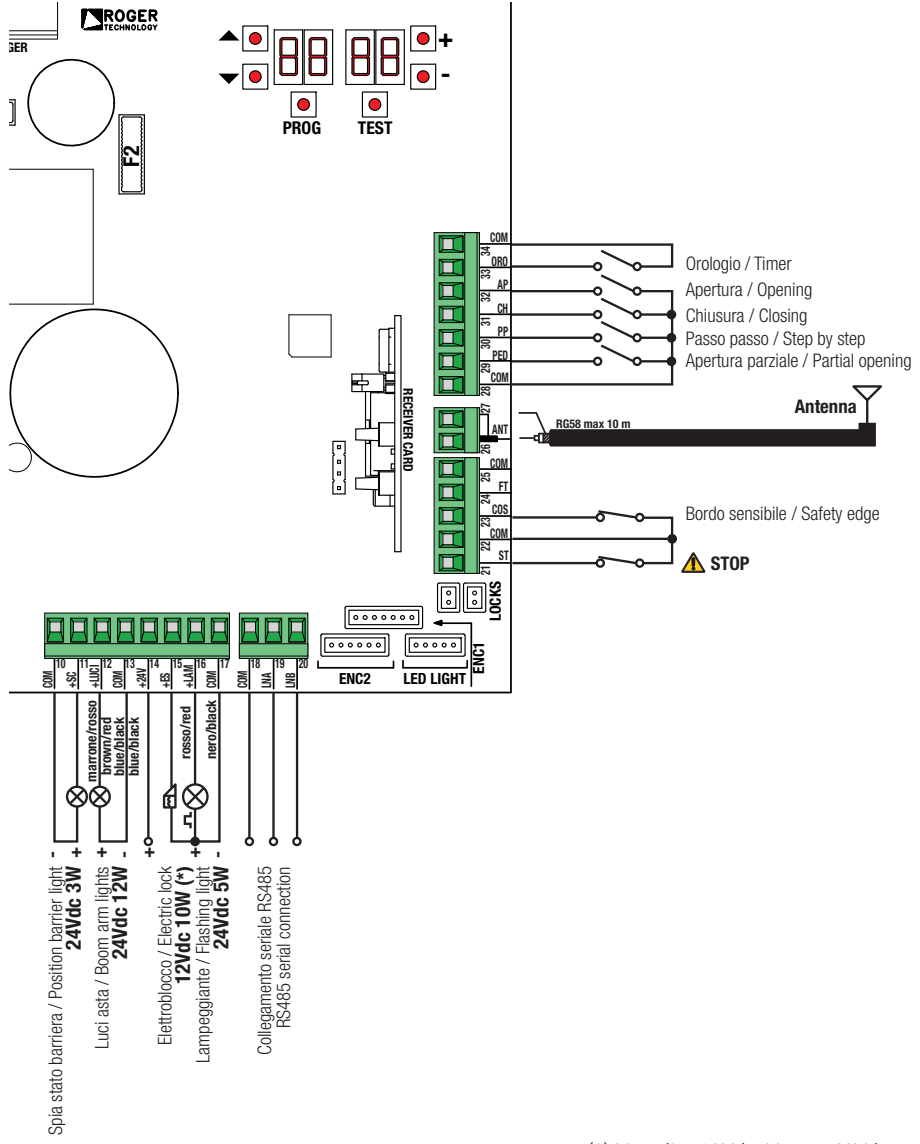

(\*) Vmedia=12Vdc; Vmax=40Vdc  
 (\*) Vaverage=12Vdc; Vmax=40Vdc



**COLLEGAMENTO CON 1 COPPIA FOTOCELLELE SINCRONIZZATE (MODALITÀ NORMALE, SOLO COPPIA MASTER)**  
**CONNECTION WITH 1 SYNCHRONISED PHOTOCELL PAIR (NORMAL MODE, MASTER PAIR ONLY)**

ROSSO = libero da jumper  
 RED = jumper free

4

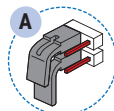
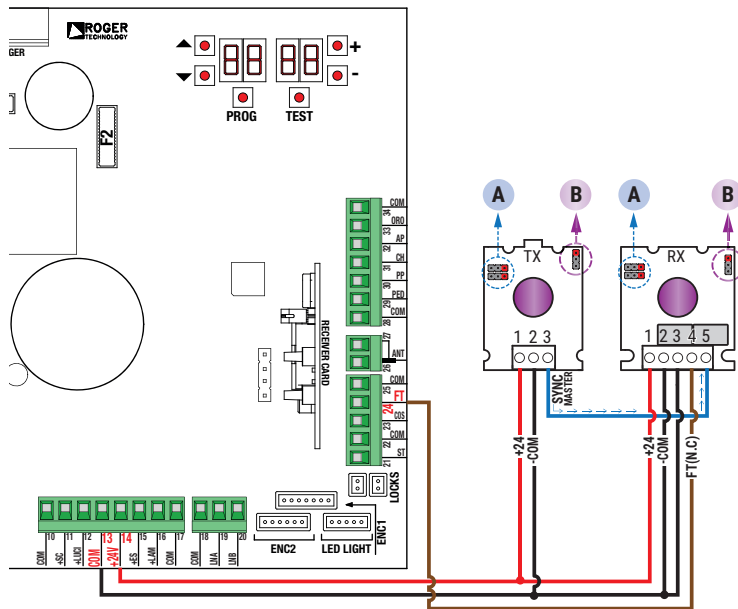

**JUMPER DI SINCRONIZZAZIONE (PER MASTER)**  
**SYNCHRONISATION JUMPER (FOR MASTER)**

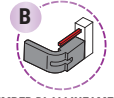

**JUMPER DI ALLINEAMENTO (PER MASTER) OFF\***  
**ALIGNMENT JUMPER (FOR MASTER) OFF\***

\* Per eseguire la modalità in di allineamento ottico (NOTA: consultare le istruzioni delle fotocellule):  
 \* To perform optical alignment mode (NOTE: refer to photocell instructions):

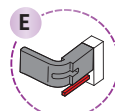
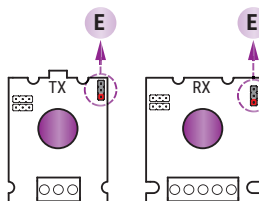

**JUMPER DI ALLINEAMENTO ON\***  
**ALIGNMENT JUMPER ON\***



**ATTENZIONE!** Modificare la posizione dei jumper di sincronizzazione o di allineamento solamente quando le fotocellule sono **NON ALIMENTATE!** La configurazione scelta con i jumper viene memorizzata dalle fotocellule solamente all'accensione delle fotocellule.

Scollegare la morsetteria della centrale che fornisce alimentazione alle fotocellule, oppure togliere completamente la tensione al controller digitale (scollegando, se presenti, anche le batterie di backup) e verificare nella fotocellula TX / RX che il LED rosso di alimentazione sia spento; procedere soltanto ora all'impostazione della configurazione dei jumper.

**ATTENTION!** Please ensure that the photocell jumpers are only changed with the power to the control panel switched off, including the disconnection of any battery backup. Remove the terminal of the photocell inputs or completely remove the voltage from the digital controller (check that the digital controller is not powered by backup batteries) and check that the TX / RX photocell red power LED is off.

**SI RACCOMANDA L'USO DI fotocellule Serie F4ES - F4S / RECOMMENDED USE for Series F4ES - F4S photocells**

**COLLEGAMENTO CON 2 COPPIE FOTOCELLULE SINCRONIZZATE (MODALITÀ NORMALE, 1 MASTER E 1 SLAVE)**  
**CONNECTION WITH 2 SYNCHRONISED PHOTOCELL PAIRS (NORMAL MODE, 1 MASTER AND 1 SLAVE)**

ROSSO = libero da jumper  
 RED = jumper free

4

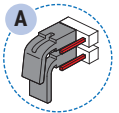
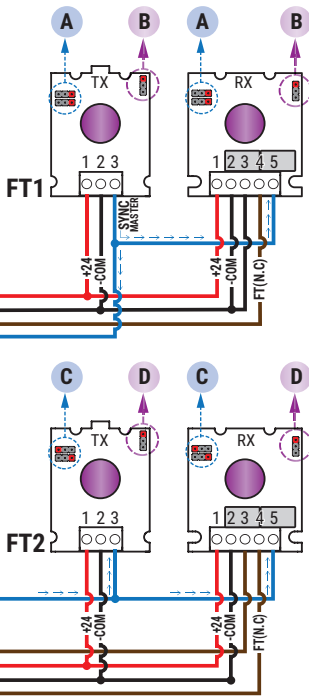
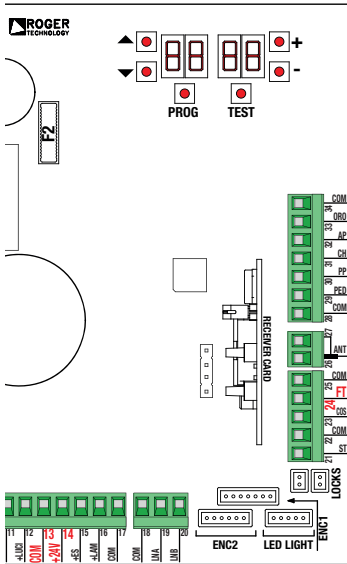

**JUMPER DI SINCRONIZZAZIONE (PER MASTER)**  
**SYNCHRONISATION JUMPER (FOR MASTER)**

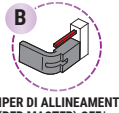

**JUMPER DI ALLINEAMENTO (PER MASTER) OFF\***  
**ALIGNMENT JUMPER (FOR MASTER) OFF\***

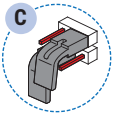

**JUMPER DI SINCRONIZZAZIONE (PER SLAVE1)**  
**SYNCHRONISATION JUMPER (FOR SLAVE1)**



**JUMPER DI ALLINEAMENTO (PER SLAVE1) OFF\***  
**ALIGNMENT JUMPER (FOR SLAVE1) OFF\***

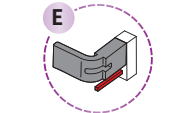
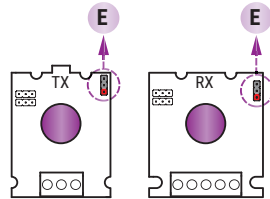

**JUMPER DI ALLINEAMENTO ON\***  
**ALIGNMENT JUMPER ON\***

\* Per eseguire la modalità in di allineamento ottico (NOTA: consultare le istruzioni delle fotocellule):  
 \* To perform optical alignment mode (NOTE: refer to photocell instructions):



**ATTENZIONE!** Modificare la posizione dei jumper di sincronizzazione o di allineamento solamente quando le fotocellule sono **NON ALIMENTATE!** La configurazione scelta con i jumper viene memorizzata dalle fotocellule solamente all'accensione delle fotocellule.

Scollegare la morsetteria della centrale che fornisce alimentazione alle fotocellule, oppure togliere completamente la tensione al controller digitale (scollegando, se presenti, anche le batterie di backup) e verificare nella fotocellula TX / RX che il LED rosso di alimentazione sia spento; procedere soltanto ora all'impostazione della configurazione dei jumper.

**ATTENTION!** Please ensure that the photocell jumpers are only changed with the power to the control panel switched off, including the disconnection of any battery backup. Remove the terminal of the photocell inputs or completely remove the voltage from the digital controller (check that the digital controller is not powered by backup batteries) and check that the TX / RX photocell red power LED is off.

**SI RACCOMANDA L' USO DI fotocellule Serie F4ES - F4S / RECOMMENDED USE for Series F4ES - F4S photocells**

# TEST FOTOCELLULE · PHOTOCELLS TEST (AB 02)

## COLLEGAMENTO CON 1 COPPIA FOTOCELLULE SINCRONIZZATE (MODALITÀ NORMALE, SOLO COPPIA MASTER) CONNECTION WITH 1 SYNCHRONISED PHOTOCCELL PAIR (NORMAL MODE, MASTER PAIR ONLY)

ROSSO = libero da jumper  
RED = jumper free

5

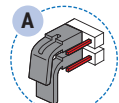
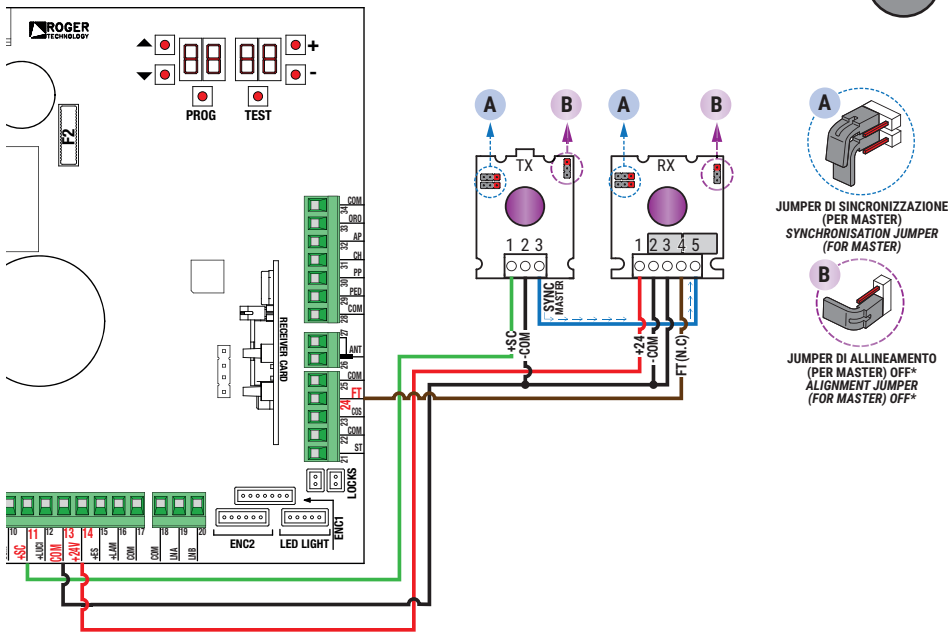

JUMPER DI SINCRONIZZAZIONE (PER MASTER)  
SYNCHRONISATION JUMPER (FOR MASTER)

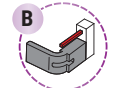

JUMPER DI ALLINEAMENTO (PER MASTER) OFF\*  
ALIGNMENT JUMPER (FOR MASTER) OFF\*

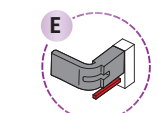
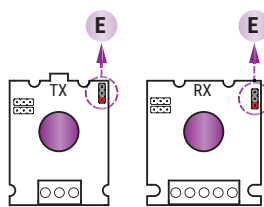

JUMPER DI ALLINEAMENTO ON\*  
ALIGNMENT JUMPER ON\*

\* Per eseguire la modalità in di allineamento ottico (NOTA: consultare le istruzioni delle fotocellule):  
\* To perform optical alignment mode (NOTE: refer to photocell instructions):



**ATTENZIONE!** Modificare la posizione dei jumper di sincronizzazione o di allineamento solamente quando le fotocellule sono **NON ALIMENTATE!** La configurazione scelta con i jumper viene memorizzata dalle fotocellule solamente all'accensione delle fotocellule.

Scollegare la morsetteria della centrale che fornisce alimentazione alle fotocellule, oppure togliere completamente la tensione al controller digitale (scollegando, se presenti, anche le batterie di backup) e verificare nella fotocellula TX / RX che il LED rosso di alimentazione sia spento; procedere soltanto ora all'impostazione della configurazione dei jumper.

**ATTENTION!** Please ensure that the photocell jumpers are only changed with the power to the control panel switched off, including the disconnection of any battery backup. Remove the terminal of the photocell inputs or completely remove the voltage from the digital controller (check that the digital controller is not powered by backup batteries) and check that the TX / RX photocell red power LED is off.

SI RACCOMANDA L'USO DI fotocellule Serie F4ES - F4S / RECOMMENDED USE for Series F4ES - F4S photocells

# TEST FOTOCELLULE · PHOTOCELLS TEST (AB 02)

## COLLEGAMENTO CON 2 COPPIE FOTOCELLULE SINCRONIZZATE (MODALITÀ NORMALE, 1 MASTER E 1 SLAVE) CONNECTION WITH 2 SYNCHRONISED PHOTOCCELL PAIRS (NORMAL MODE, 1 MASTER AND 1 SLAVE)

ROSSO = libero da jumper  
RED = jumper free

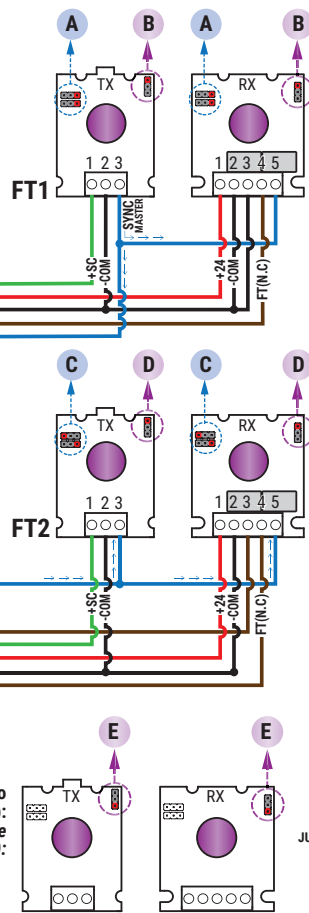
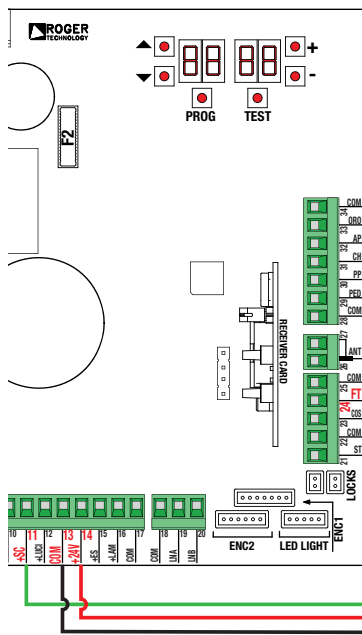

5

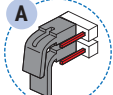

JUMPER DI SINCRONIZZAZIONE (PER MASTER)  
SYNCHRONISATION JUMPER (FOR MASTER)

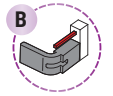

JUMPER DI ALLINEAMENTO (PER MASTER) OFF\*  
ALIGNMENT JUMPER (FOR MASTER) OFF\*

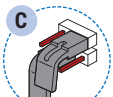

JUMPER DI SINCRONIZZAZIONE (PER SLAVE)  
SYNCHRONISATION JUMPER (FOR SLAVE)

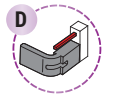

JUMPER DI ALLINEAMENTO (PER SLAVE) OFF\*  
ALIGNMENT JUMPER (FOR SLAVE) OFF\*

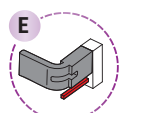

JUMPER DI ALLINEAMENTO ON\*  
ALIGNMENT JUMPER ON\*

\* Per eseguire la modalità in di allineamento ottico (NOTA: consultare le istruzioni delle fotocelle):  
\* To perform optical alignment mode (NOTE: refer to photocell instructions):



**ATTENZIONE!** Modificare la posizione dei jumper di sincronizzazione o di allineamento solamente quando le fotocelle sono **NON ALIMENTATE!** La configurazione scelta con i jumper viene memorizzata dalle fotocelle solamente all'accensione delle fotocelle.

Scollegare la morsetteria della centrale che fornisce alimentazione alle fotocelle, oppure togliere completamente la tensione al controller digitale (scollegando, se presenti, anche le batterie di backup) e verificare nella fotocella TX / RX che il LED rosso di alimentazione sia spento; procedere soltanto ora all'impostazione della configurazione dei jumper.

**ATTENTION!** Please ensure that the photocell jumpers are only changed with the power to the control panel switched off, including the disconnection of any battery backup. Remove the terminal of the photocell inputs or completely remove the voltage from the digital controller (check that the digital controller is not powered by backup batteries) and check that the TX / RX photocell red power LED is off.

**SI RACCOMANDA L' USO DI** fotocelle Serie F4ES - F4S / **RECOMMENDED USE for** Series F4ES - F4S photocells



# BATTERY SAVING (AB 03)

# BATTERY SAVING + TEST FOTOCELLULE · PHOTOCELLS TEST (AB 04)

## COLLEGAMENTO CON 2 COPPIE FOTOCELLULE SINCRONIZZATE (MODALITÀ NORMALE, 1 MASTER E 1 SLAVE) CONNECTION WITH 2 SYNCHRONISED PHOTOCCELL PAIRS (NORMAL MODE, 1 MASTER AND 1 SLAVE)

ROSSO = libero da jumper  
RED = jumper free

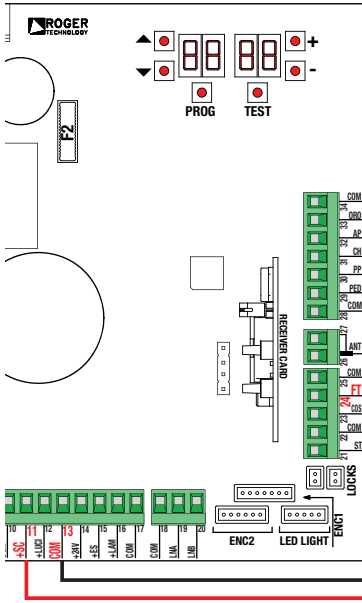

6

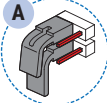

JUMPER DI SINCRONIZZAZIONE (PER MASTER)  
SYNCHRONISATION JUMPER (FOR MASTER)

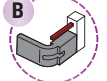

JUMPER DI ALLINEAMENTO (PER MASTER) OFF\*  
ALIGNMENT JUMPER (FOR MASTER) OFF\*

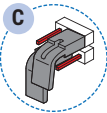

JUMPER DI SINCRONIZZAZIONE (PER SLAVE)  
SYNCHRONISATION JUMPER (FOR SLAVE)

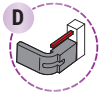

JUMPER DI ALLINEAMENTO (PER SLAVE) OFF\*  
ALIGNMENT JUMPER (FOR SLAVE) OFF\*

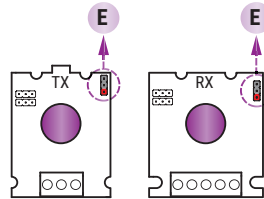

JUMPER DI ALLINEAMENTO ON\*  
ALIGNMENT JUMPER ON\*

\* Per eseguire la modalità in di allineamento ottico (NOTA: consultare le istruzioni delle fotocellule):  
\* To perform optical alignment mode (NOTE: refer to photocell instructions):



**ATTENZIONE!** Modificare la posizione dei jumper di sincronizzazione o di allineamento solamente quando le fotocellule sono **NON ALIMENTATE!** La configurazione scelta con i jumper viene memorizzata dalle fotocellule solamente all'accensione delle fotocellule.

Scollegare la morsetteria della centrale che fornisce alimentazione alle fotocellule, oppure togliere completamente la tensione al controller digitale (scollegando, se presenti, anche le batterie di backup) e verificare nella fotocellula TX / RX che il LED rosso di alimentazione sia spento; procedere soltanto ora all'impostazione della configurazione dei jumper.

**ATTENTION!** Please ensure that the photocell jumpers are only changed with the power to the control panel switched off, including the disconnection of any battery backup. Remove the terminal of the photocell inputs or completely remove the voltage from the digital controller (check that the digital controller is not powered by backup batteries) and check that the TX / RX photocell red power LED is off.

**SI RACCOMANDA L' USO DI** fotocellule Serie F4ES - F4S / **RECOMMENDED USE for** Series F4ES - F4S photocells

7

G90/F4ES

T90/F4S

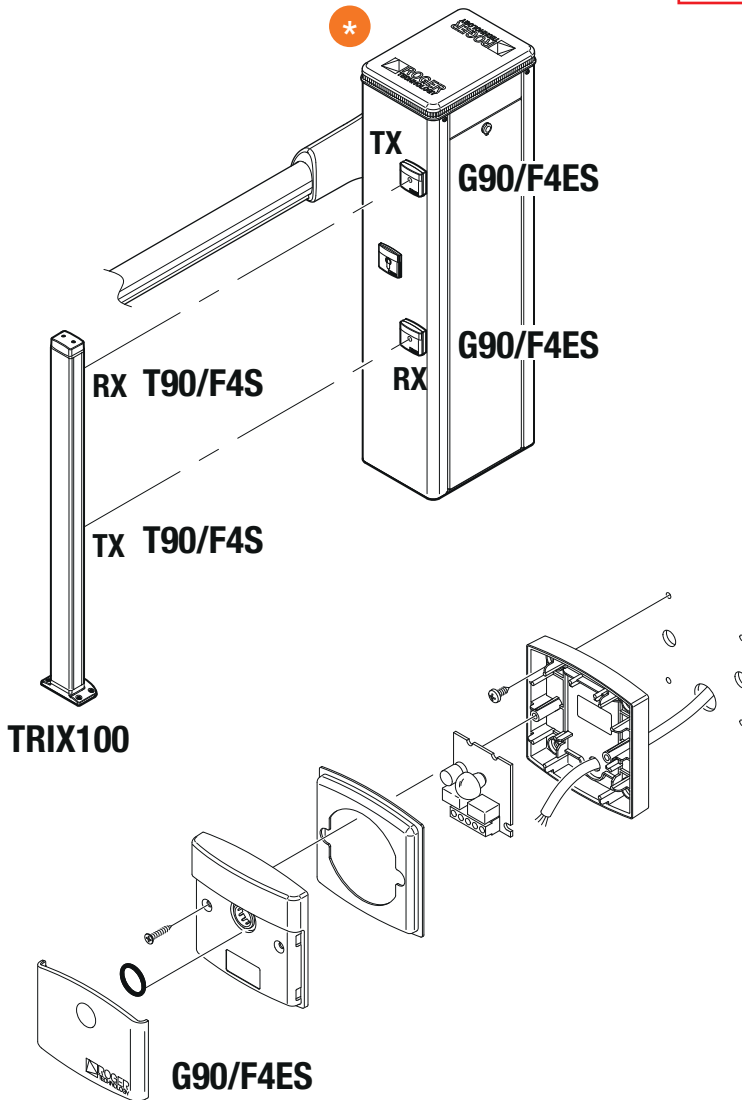

\* L'immagine della barriera ha scopo puramente indicativo.  
The image of the barrier is for reference only.

**CONNESSIONE CON ACS/BA/60**  
**CONNECTION WITH ACS/BA/60**

8

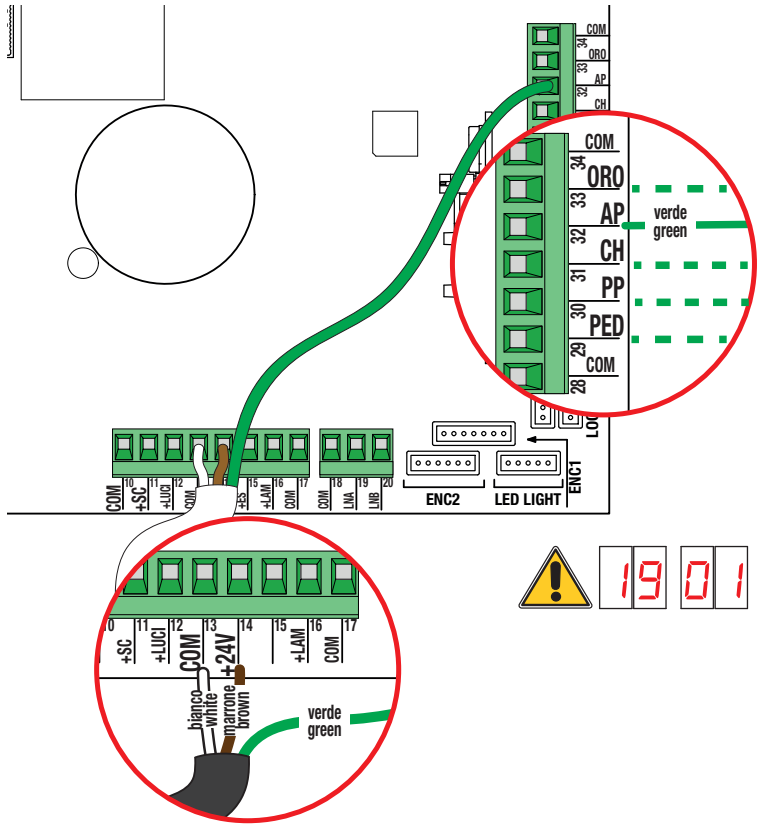

9



Utilizzo alternativo dell'uscita SC (par.20 diverso da 00).  
 Alternative use of SC output (par.20 different from 00).

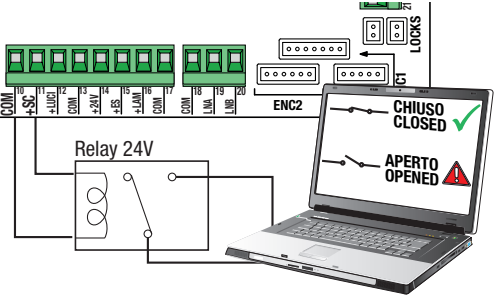
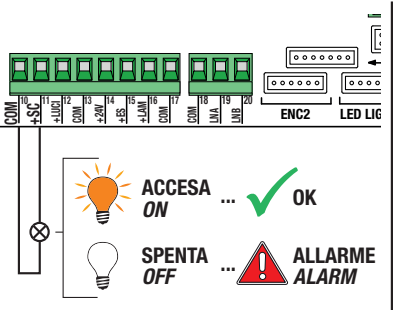



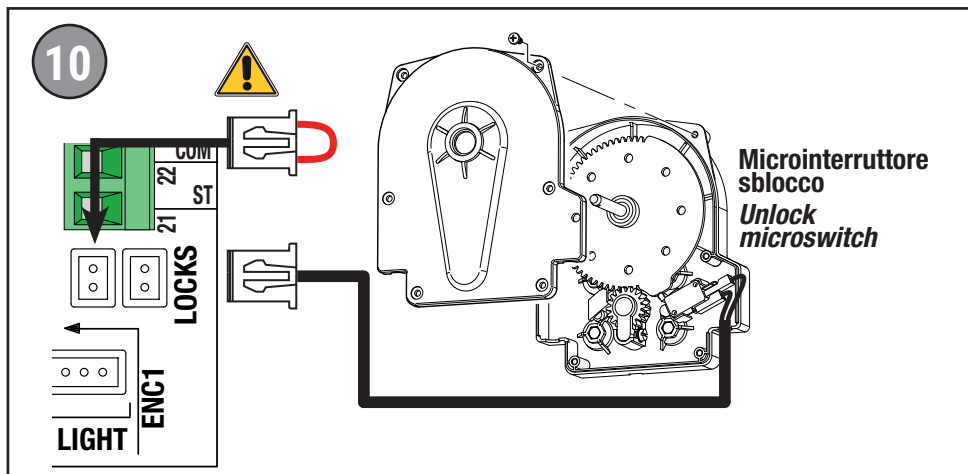

## BIONIK4

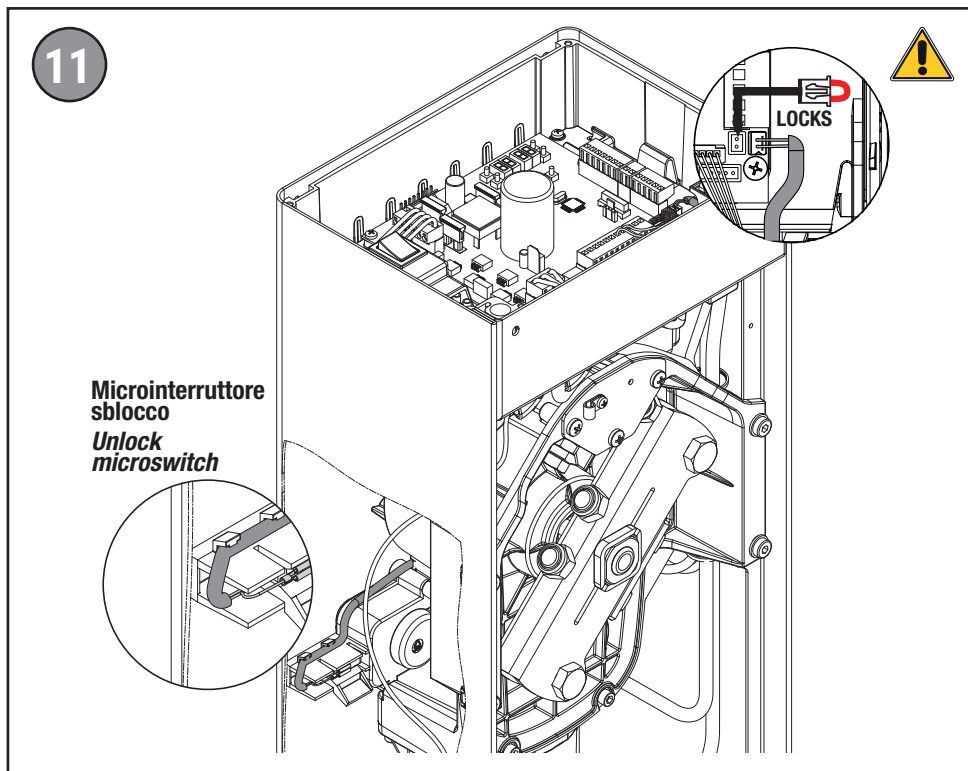

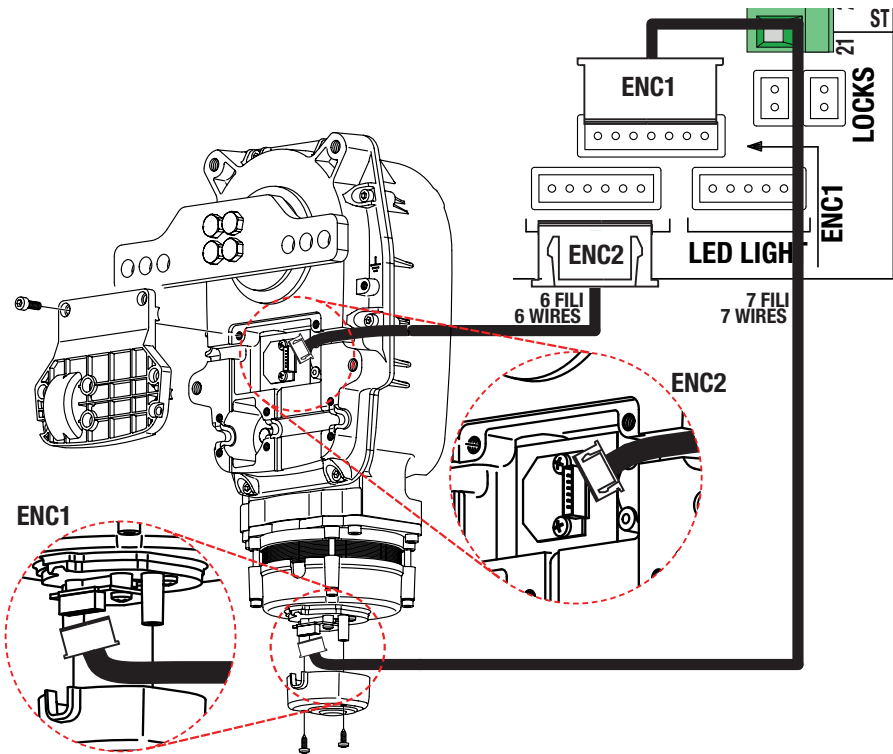

# BIONIK4

13

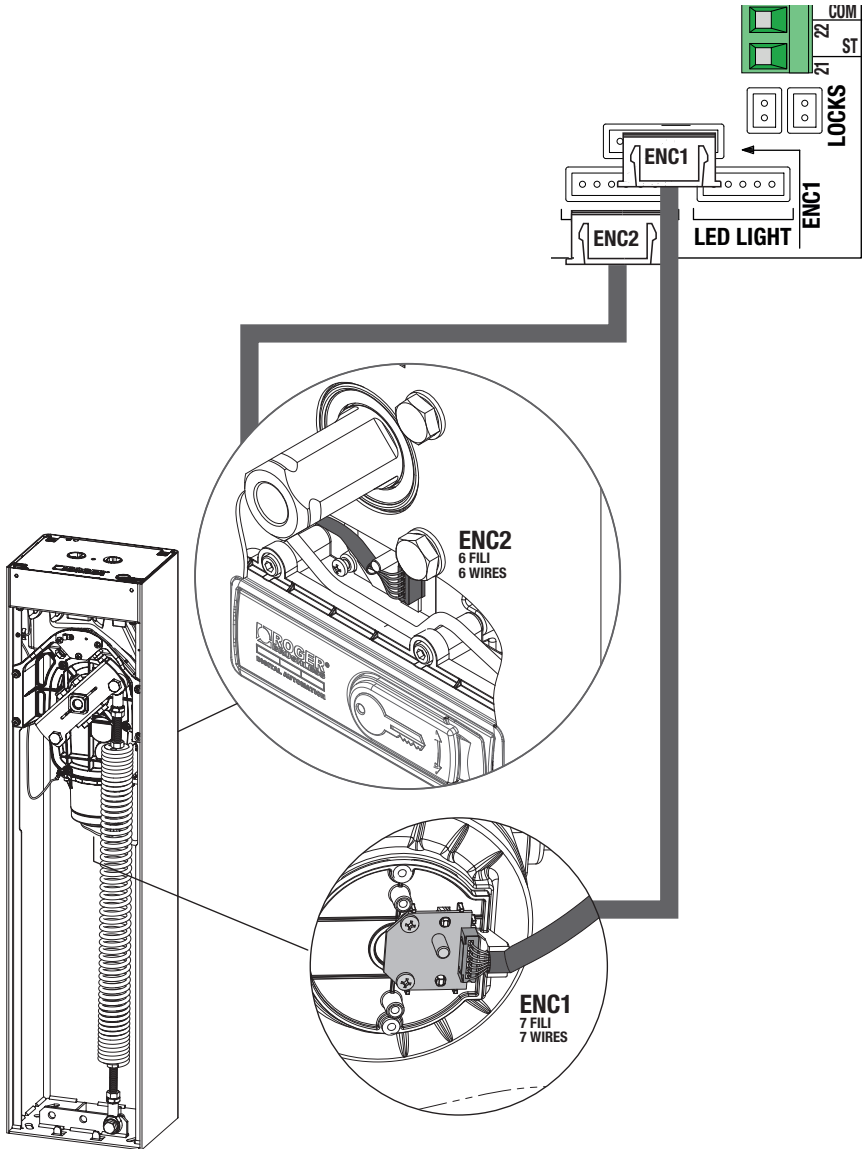

AG/BLED

B73/EXP

14

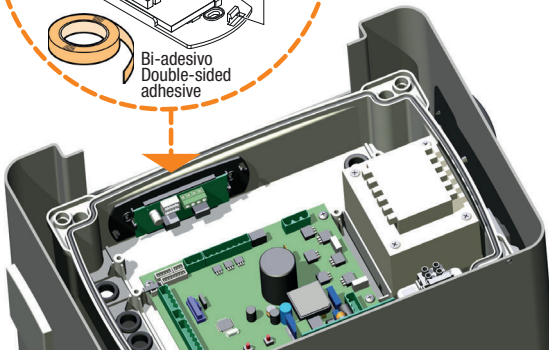
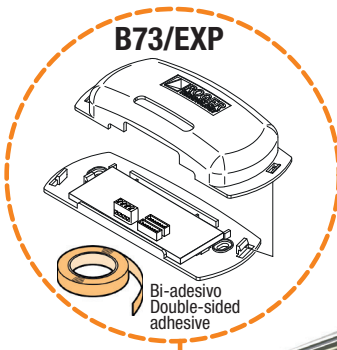
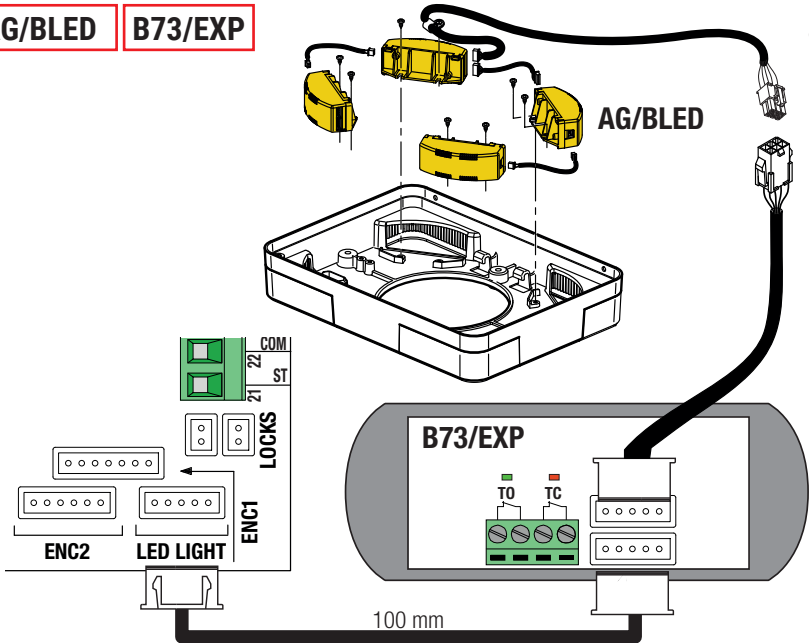

# BIONIK4 • BIONIK4HP • BIONIK6 • BIONIK8

15

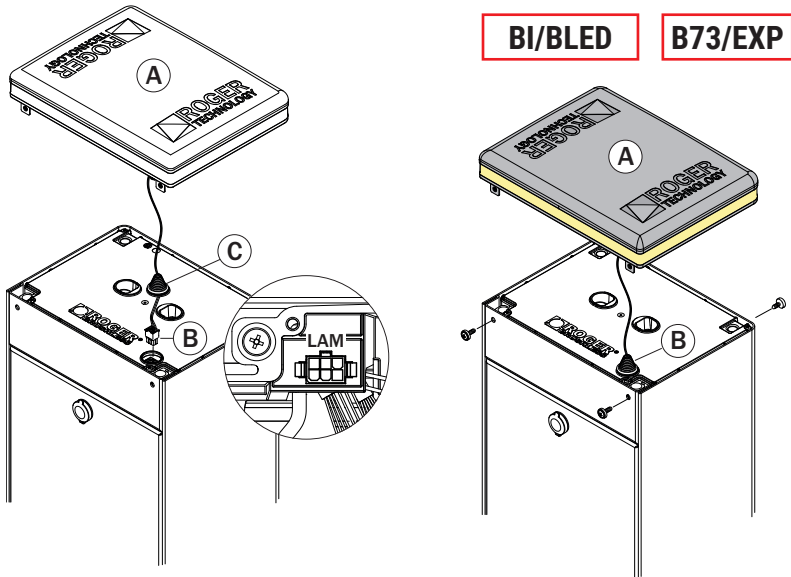

BI/BLED

B73/EXP

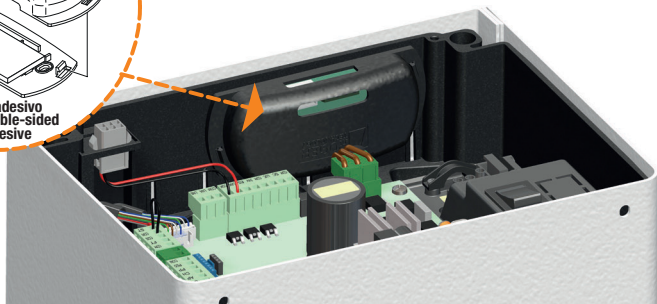
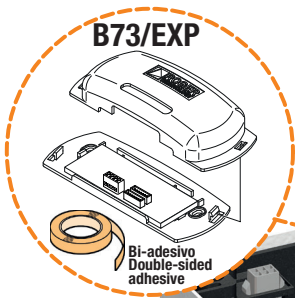
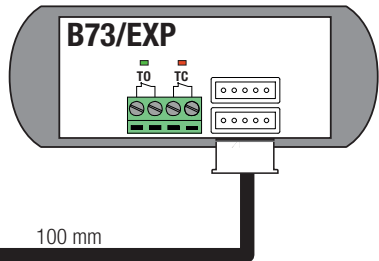
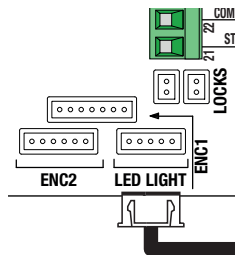

**MESSA A TERRA  
GROUNDING SCHEME**

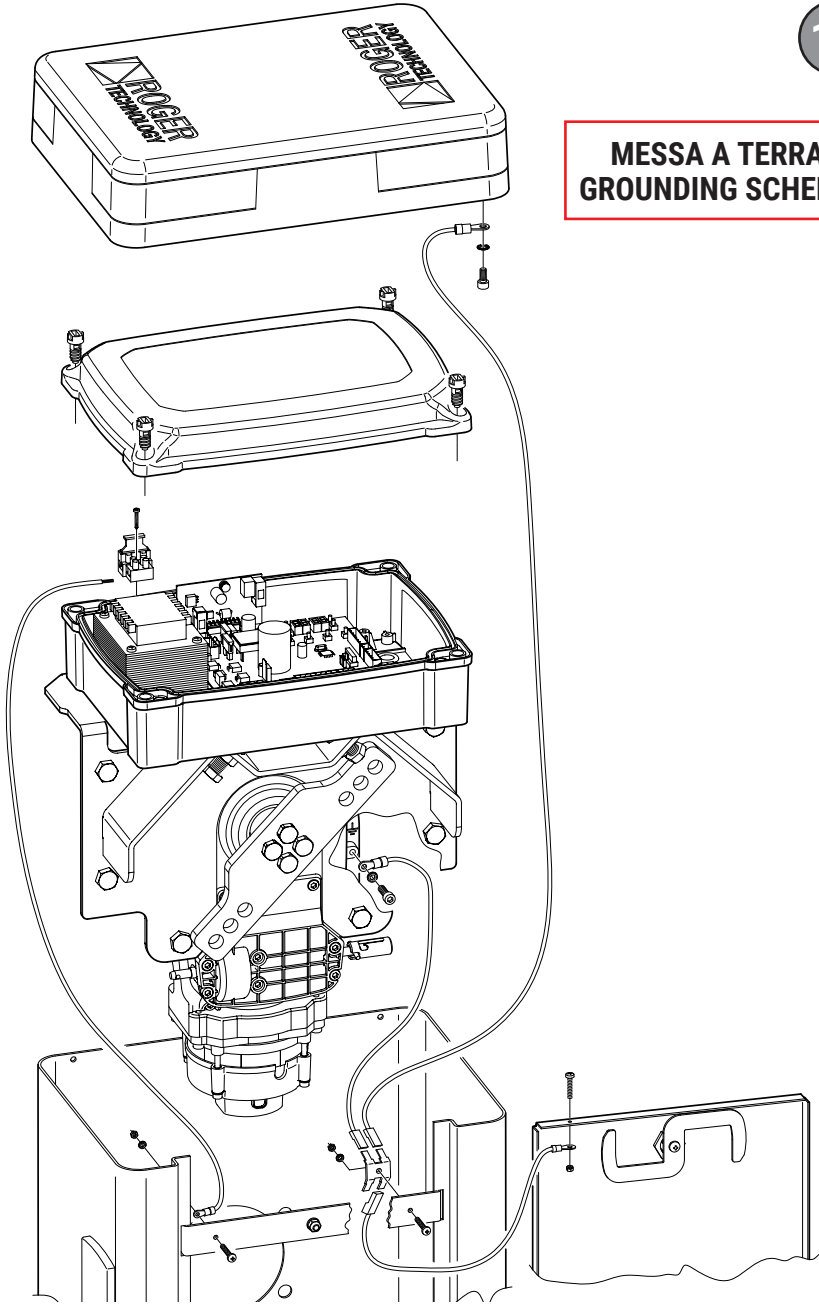

17

**MESSA A TERRA  
GROUNDING SCHEME**

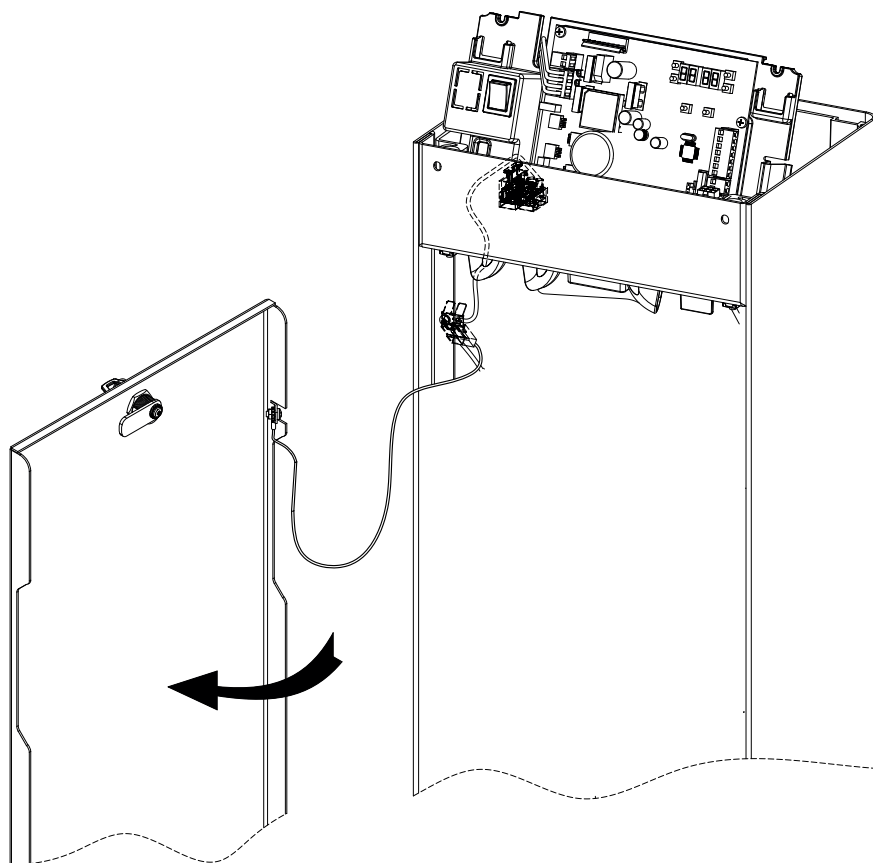

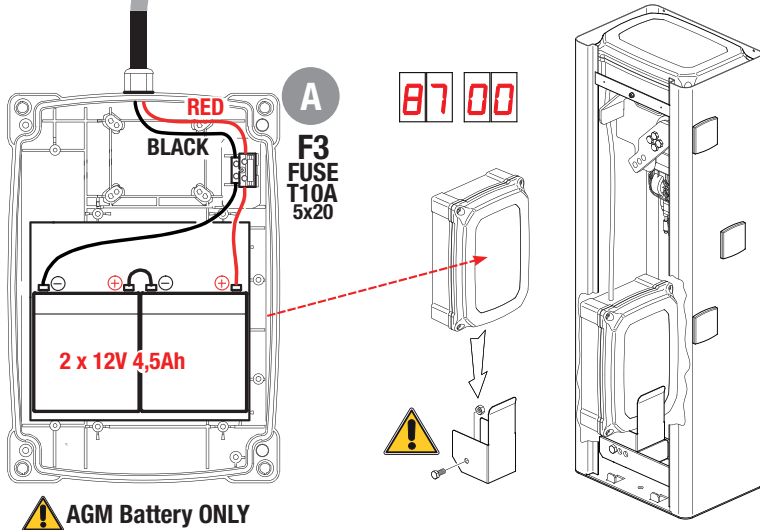
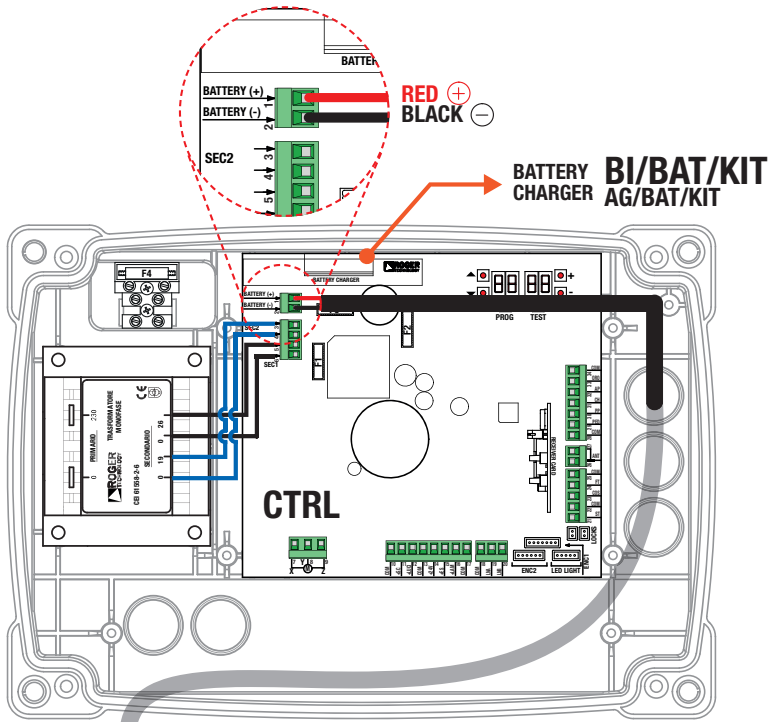



19

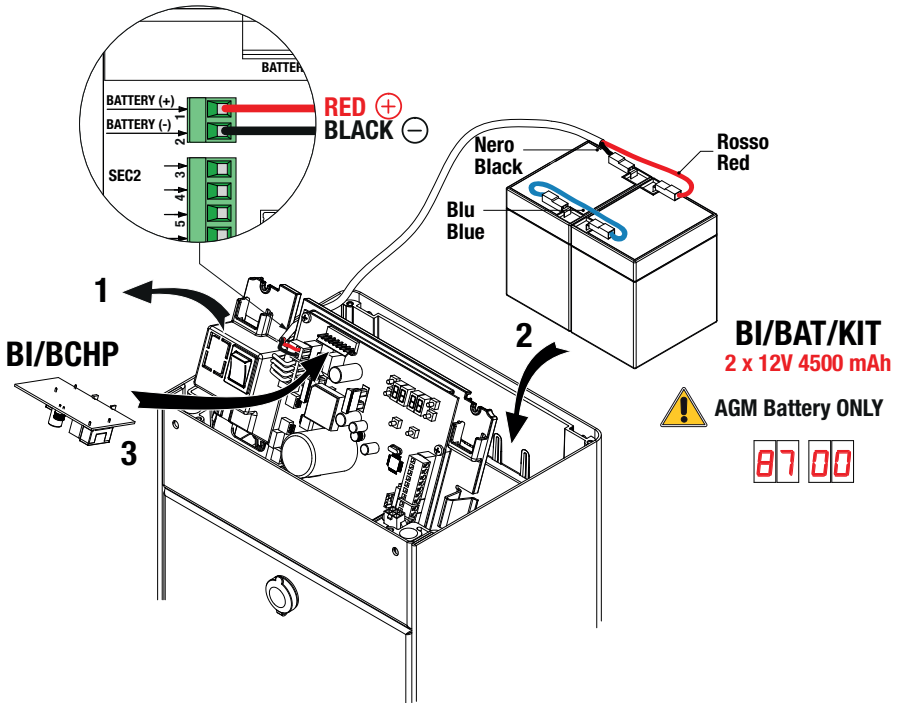

# COLLEGAMENTO BARRIERA IN MASTER/SLAVE VIA BUS MASTER/SLAVE BARRIER CONNECTION VIA BUS

20

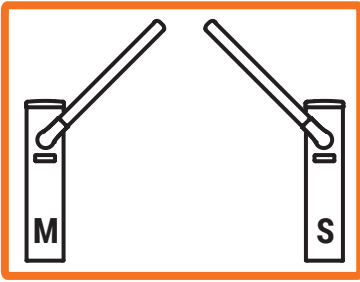

**MASTER**  
AD 11

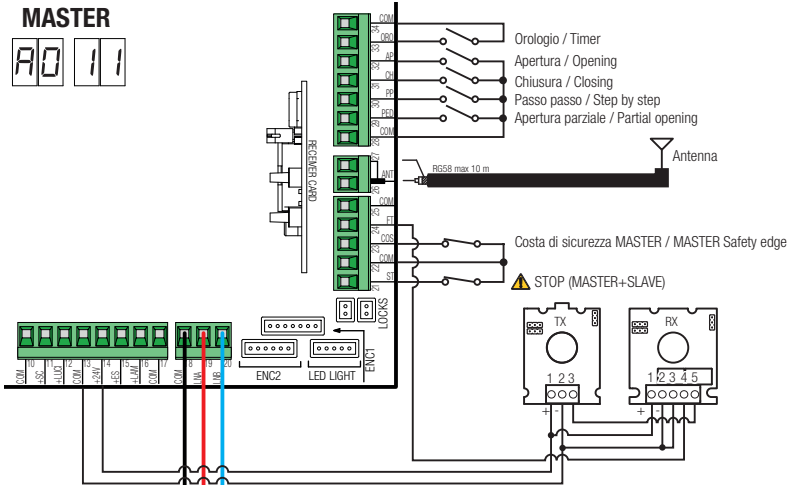

**SLAVE**  
AD 10

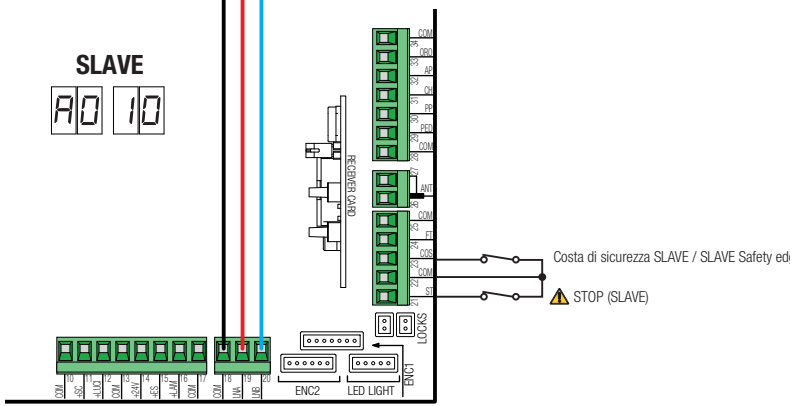

21

**ATTENZIONE: POSIZIONARSI SEMPRE DI FRONTE ALL' ARMADIO DELLA BARRIERA DAL LATO DELLA PORTA DI ISPEZIONE**  
**ATTENTION: STAY ALWAYS IN FRONT OF THE BARRIER CABINET FROM THE SIDE OF THE INSPECTION DOOR**

**PARAMETRIZZAZIONE DELLA POSIZIONE DELL' INSTALLAZIONE DELLA BARRIERA CON POSIZIONAMENTO DELL' ARMADIO A SINISTRA E VARCO PASSAGGIO DELL' ASTA A DESTRA**  
**PARAMETERIZATION OF THE INSTALLATION POSITION OF THE BARRIER WITH POSITIONING OF THE CABINET ON THE LEFT AND PASSAGE OF THE BOOM ARM ON THE RIGHT**



**PARAMETRIZZAZIONE DELLA POSIZIONE DELL' INSTALLAZIONE DELLA BARRIERA CON POSIZIONAMENTO DELL' ARMADIO A DESTRA E VARCO PASSAGGIO DELL' ASTA A SINISTRA**  
**PARAMETERIZATION OF THE INSTALLATION POSITION OF THE BARRIER WITH POSITIONING OF THE CABINET ON THE RIGHT AND PASSAGE OF THE BOOM ARM ON THE LEFT**

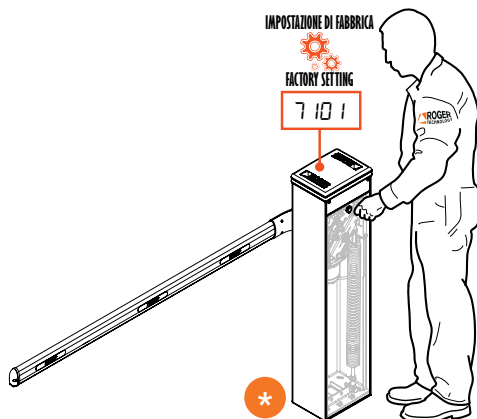

\* L'immagine della barriera ha scopo puramente indicativo.  
\* The image of the barrier is for reference only.

# 1 General safety precautions

---



## **WARNING: IMPORTANT SAFETY INSTRUCTIONS THESE INSTRUCTIONS MUST BE FOLLOWED TO GUARANTEE THE SAFETY OF THE PERSONS PRESERVE THESE INSTRUCTIONS**

This installation manual is intended for qualified personnel only.

 Failure to observe the information included in this manual may result in personal injury or damage to the equipment.

ROGER TECHNOLOGY cannot be held responsible for any damage or injury due to improper use or any use other than the intended usage indicated in this manual.

The installation, electrical connections and adjustments must be performed by qualified personnel, in accordance with best practices and in compliance with applicable regulations.

Read the instructions carefully before installing the product.

Incorrect installation may pose risks.

Before installing the product, make sure it is in perfect condition: In case of doubts, do not use the product and refer exclusively to professionally qualified personnel.

Do not install the product in explosive environment and atmosphere: inflammable gas or vapours constitute serious danger for safety.

Before installing the motor, make all structural modifications related to the safety precautions and to the protection or segregation of areas involving crushing, shearing, dragging risks or any other risks.

**WARNING:** check that the existing structure fulfils the required resistance and stability specifications.

ROGER TECHNOLOGY is not liable for failure to observe the good practices in the construction of fixtures to be motorised or for deformations that may occur during use.

The safety devices (photocells, sensing edges, emergency stops, etc.) must be installed taking into consideration the following: the regulations and directives in force, the good practices criteria, the installation environment, the operating logic of the system and the forces generated by the motorised door or gate.

The safety devices must protect any areas where there is crushing, shearing, dragging or any other danger in general generated by the motorised door or gate; the installer is advised to check that the moving wings do not have sharp edges or anything that may pose shearing and/or dragging risks.

If it is deemed necessary based on the risk analysis, install sensing edges on the mobile part.

It should be noted that, as provided by the UNI EN 12635 standard, all requirements of the EN 12604 and EN 12453 standards must be fulfilled and, if

necessary, also checked.

The European standards EN 12453 and EN 12445 define the minimum safety requirements for the operation of automatic doors and gates. In particular, these standards require the use of force limiting and safety devices (sensing ground plates, photocell barriers, hold-to-run operation, etc.) intended to detect persons or objects in the operating area and prevent collisions in all circumstances.

The installer is required to measure impact forces and select on the control unit the appropriate speed and torque values to ensure that the door or gate remains within the limits defined by the standards EN 12453 and EN 12445.

ROGER TECHNOLOGY cannot be held responsible for any damage or injury caused by the installation of incompatible components which compromise the safety and correct operation of the device.

If the hold-to-run function is active, the installer will have the obligation to check the maximum stop distance or the alternative use of the rubber deformable edge, the closing speed or the gate and in general all aspects indicated by the applicable regulations. Moreover, please note that if the command means is fixed, it must be located in a position guaranteeing the automation system control and operation and the command type and the use type must comply with the UNI EN 12453 standard, prospectus 1 (with the following restrictions: type A or B command or type 1 or 2 use).

In case of hold-to-run operation, remove any potential persons away from the range of action of the automation system's moving parts; the direct commands must be installed at a minimum height of 1.5 m and must not be accessible to the public; moreover, unless the device is key operated, they must be located with a direct view to the motorised part and far from the moving parts.

Apply the signs indicated by the regulations in force for the identification of the dangerous areas.

Each installed device must have a visible indication of the motorised door or gate identification data, in accordance with the EN 13241-1:2001 standard or subsequent revisions



A switch or an omnipolar cut-off switch with a contact opening of at least 3 mm must be installed on the mains power line; put the cut-off switch in OFF position and disconnect any buffer batteries before performing any cleaning or maintenance operations.

Ensure that an adequate residual current circuit breaker with a 0.03 A threshold and a suitable overcurrent cut-out are installed upstream the electrical installation in accordance with best practices and in compliance with applicable legislation.

When requested, connect the automation to an effective earthing system that complies with current safety standards.

The electronic parts must be handled using anti-static conductive wrist straps with grounding wire.

Only use original spare parts when repairing or replacing products.

The installer must provide the user with complete instruction for using the motorised door or gate in automatic, manual and emergency modes, and must

hand the operating instructions to the user of the installation upon completion. Keep away from hinges and moving parts.

Keep out of the area of action of the motorised door or gate while it is moving. Never try to stop the motorised door or gate while it is moving as this may be dangerous.

The motorised door or gate may be used by children aged 8 and above, by persons with diminished physical, sensory or mental capacity and by persons without the necessary experience and knowledge provided that they are supervised or have received adequate instruction on using the device safely and to ensure that they understand the dangers involved in its operation. Children must be supervised at all times to ensure that they do not play with the device and that they keep out of the area of action of the motorised door or gate.

Keep remote controls and any other control devices out of the reach of children to prevent the risk of the motorised door or gate being operated unintentionally. Failure to observe these instructions may lead to danger.

Any repair or technical interventions must be performed by qualified personnel. The cleaning and maintenance operations must be performed exclusively by qualified personnel.

In the event of a fault or malfunction of the product, turn the main power switch off and have the installation serviced by qualified personnel and refrain from attempting to repair or perform any direct intervention yourself.

The packaging materials (plastic, polystyrene, etc.) should not be discarded in the environment or left within reach of children, as they are a potential source of danger.

Dispose of and recycle the packaging items according to the provisions of the laws in force.

These instructions must be kept and must be made available to any other persons authorised to use the installation.

## Declaration CE of Conformity

---

The undersigned Dino Florian, legal representative of **Roger Technology - Via Botticelli 8, 31021 Mogliano V.to (TV)** DECLARES that the **CTRL** digital control unit is compliant with the provisions established by Community directives:

- 2014/35/EU LVD Standard
- 2014/30/EU EMC Standard
- 2014/53/EU RED Standard
- 2011/65/CE RoHS Standard











Place: Mogliano V.to  
Date: 14/01/2014

Signature



## 2 Symbols

The symbols and their meaning in the manual or on the product label are indicated below.

	<b>Generic danger.</b> Important safety information. Indicates operations and situations in which the personnel involved must pay close attention.
	<b>Dangerous voltage risk.</b> Indicates operations and situations in which the personnel involved must pay close attention to dangerous voltages.
	<b>Hot surfaces risk.</b> Indicates danger due to hot surfaces or which anyway have high temperatures (risk of burns).
	<b>Useful information.</b> Indicates useful information for the installation.
	<b>Refer to the Installation and use instructions.</b> Indicates the obligation to refer to the manual or original document, which must be available for future use and must not be damaged in any way.
	Protective earth connection point.
	Indicates the admissible temperature range.
	Alternating current (AC)
	Direct current (DC)
	Symbol for the product disposal according to the WEEE directive, see chapter 22.

## 3 Product description

The **CTRL** controller is a unit for the sensed control of the ROGER brushless motor powering an electromechanical barrier. The **CTRL** uses two magnetic encoders, with one monitoring the motor and another monitoring the position of the boom, even when it is moved manually.

 **Ensure that the parameter A1 is set correctly. If this parameter is not set correctly, the automation system may not function properly.**

Two opposing barriers may be connected with a RS485 serial communication cable. This capability is only available with firmware version 1.3 (n6 13) or later.  
We recommend using only ROGER TECHNOLOGY accessories and control and safety devices. Specifically, we recommend installing **F4ES** or **F4S** series photocells.

ROGER TECHNOLOGY cannot be held responsible for any damage or injury due to improper use or any use other than the intended usage indicated in this manual.



 For further information, refer to the installation manual of the BIONIK4, BIONIK4HP, BIONIK6, BIONIK8 automation system

# 4 Updates of version P4.10



1. Added a selection to par. 29.

## 5 Technical characteristics of product

	AG/004 AG/006 KB/004 KB/006 BI/004HP BI/006 BI/008	BI/004	AG/004/115 AG/006/115 KB/004/115 KB/006/115 BI/004HP/115 BI/006/115 BI/008/115	BI/004/115
<b>MAINS POWER VOLTAGE</b>	230 V~ ± 10% 50Hz		115V~ ± 10% 60Hz	
<b>MAXIMUM MAINS POWER ABSORPTION</b>	240 W			
<b>FUSES</b>	<b>F1</b> = 10A (ATO257) motor power circuit protection <b>F2</b> = 4A (ATO257) electric lock protection <b>F3</b> = 3A (ATO257) accessories power supply protection			
	<b>F4</b> = T1A (5x20 mm) primary transformer coil protection		<b>F4</b> = T2A (5x20 mm) primary transformer coil protection	
<b>NUMBER OF CONNECTABLE MOTORS</b>	1			
<b>MOTOR POWER SUPPLY</b>	36 V~			
<b>MOTOR TYPE</b>	sinusoidal drive brushless (ROGER BRUSHLESS)			
<b>MOTOR CONTROL TYPE</b>	"sensored", with field oriented control (FOC)			
<b>MAXIMUM MOTOR POWER</b>	220 W			
<b>MAXIMUM POWER, EXTERNAL FLASHING LIGHT</b>	5 W 24 V===			
<b>MAXIMUM POWER, BARRIER LIGHTS</b>	12 W 24 V===			
<b>MAXIMUM POWER, ELECTRIC LOCK</b>	10W 12V=== (impulse activation, 1.5 seconds) * 5W 12V=== (normally powered electric lock) *			
<b>MAXIMUM POWER, INDICATOR LAMP</b>	3 W 24 V===			
<b>ACCESSORY OUTPUT POWER</b>	10 W 24 V===			
<b>OPERATING TEMPERATURE</b>	 -20°C  +55°C			
<b>SOUND PRESSURE DURING USE</b>	<70 dB(A)			
<b>PRODUCT DIMENSIONS</b>	Dimensions in mm.: 166x150x48 Weight: 0.254 Kg			
	<b>B73/EXP</b>			
<b>RELAY CONTACT NC</b>	2x 30 V=== 1A (potential free contact, resistive load)			

(\*) The electric lock output provides a voltage of 36Vdc nominal (max 40Vdc) modulated to 30% (30% ON, 70% OFF). The device to be connected must therefore be able to withstand a maximum voltage of 40Vdc.

EN



# 6 Description of connections

To access the control unit, remove the barrier head.

Figure 1-2-3 shows connection diagrams.

## 6.1 Typical installation

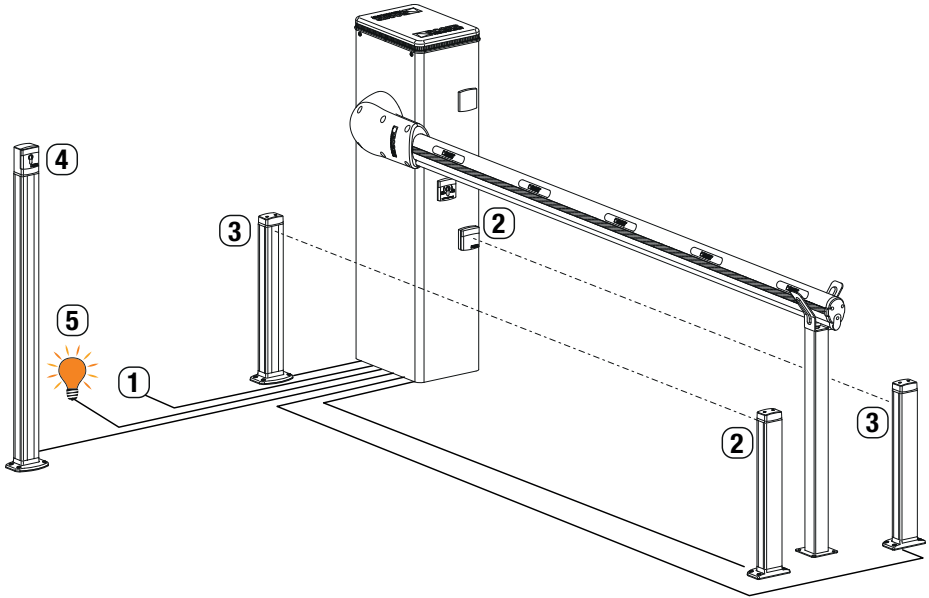

		<b>Recommended cable</b>
1	Power supply	H07RN-F 3x1,5 mm <sup>2</sup> double insulated cable
2	Photocell - Receiver <b>F4ES/F4S</b>	Cable 5x0,5 mm <sup>2</sup> (max 20 m)
3	Photocell - Transmitter <b>F4ES/F4S</b>	Cable 3x0,5 mm <sup>2</sup> (max 20 m)
4	Key selector <b>R85/60</b>	Cable 3x0,5 mm <sup>2</sup> (max 20 m)
	Keypad <b>H85/TTD - H85/TDS</b> (connecting to <b>H85/DEC - H85/DEC2</b> )	Cable 2x0,5 mm <sup>2</sup> (max 30 m)
	<b>H85/DEC - H85/DEC2</b> (connecting to control unit)	Cable 4x0,5 mm <sup>2</sup> (max 20 m) The number of conductors increases when using more than one output contact on <b>H85/DEC - H85/DEC2</b>
5	Barrier open indicator Power supply 24V DC 3W max	Cable 2x0,5 mm <sup>2</sup> (max 10 m)

**i SUGGESTIONS:** with existing installations, we recommend checking the cross section of the cables and that the cables themselves are in good condition.

## 6.2 Electrical connections

A switch or an omnipolar cut-off switch with a contact opening of at least 3 mm must be installed on the mains power line; put the cut-off switch in OFF position and disconnect any buffer batteries before performing any cleaning or maintenance operations.

Ensure that an adequate residual current circuit breaker with a 0.03 A threshold and a suitable overcurrent cut-out are installed upstream of the electrical installation in accordance with best practices and in compliance with applicable legislation.

For power supply, use a H07RN-F 3G1.5 type electric cable and connect it to the terminals L (brown), N (blue), (⊕) (yellow/green), located inside the control panel box.

Strip the insulation from the ends of the power cable wires which will be connected to the terminal (see ref. D, fig. 3-4), and secure the cable with the cable retainer.

Measure the voltage on the primary mains power connection with a tester.

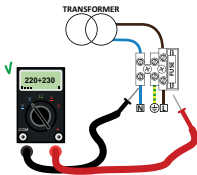

For the Brushless automation system to function correctly, the mains power voltage must be:

- 230Vac  $\pm 10\%$  for the CTRL control unit.
- 115Vac  $\pm 10\%$  for the CTRL/115 control unit.

If the detected value does not comply with the above specified values or is not stable, the automation system may NOT operate efficiently.

**i** Connections to the electrical distribution network and to any other low-voltage conductors in the external section to the electrical panel must be on an independent path and separate from the connections to the command and safety devices (SELV = Safety Extra Low Voltage).

Make sure that the mains power conductors and the accessory wires (24 V) are separated. The cables must be double insulated, strip them near the relevant connection terminals and lock them with clamps [B] (not supplied).

	DESCRIPTION
	<p>Connection to mains power, 230 Vac <math>\pm 10\%</math> (115 Vac <math>\pm 10\%</math> 60 Hz).</p> <ul style="list-style-type: none"> <li>- 230 Vac <math>\pm 10\%</math> for CTRL control panel.</li> <li>- 115 Vac <math>\pm 10\%</math> for CTRL/115 control panel.</li> </ul> <p>Fuse 5x20 T1A. Fuse 5x20 T2A (mains power 115 Vac).</p>
	<p>Secondary transformer input for 26 V AC motor power (SEC1) and for 19 V power to logical control and peripheral devices (SEC2).</p> <p><b>N.B.:</b> Ready wired in factory by ROGER TECHNOLOGY.</p>
	<p>Connection to ROGER brushless motor.</p> <p><b>N.B.:</b> Ready wired in factory by ROGER TECHNOLOGY.</p> <p><b>Warning!</b> If the motor wires become disconnected from the terminal board, after reconnecting correctly, the travel must be acquired again as described in chapter 11.</p>
	<p>Connection to the battery <b>BI/BAT/KIT</b> (see fig. 18-19).</p> <p><b>i</b> <b>See instructions for B71/BCHP or BI/BCHP for further information.</b></p>





## 7 Commands and Accessories

 If not installed, safety devices with NC contacts must be jumpered at the COM terminals, or disabled by modifying the parameters **50**, **51** and **73**.





For installations with two opposed barriers, connections for command signals and accessories must be made on the MASTER controller. The sensing edge and, if used, the STOP command signal must be connected to the SLAVE controller.

KEY:

N.A. (Normally Open) .  
N.C. (Normally Closed).

CONTACT	DESCRIPTION
<b>11(+SC)</b> <b>10(COM)</b> 	Barrier open/closed indicator lamp, 24 V DC 3 W. The function of the indicator lamp is determined by parameter <b>AB</b> .
<b>11(+SC)</b> <b>13(COM)</b>	Photocell test function and/r battery saving mode connection (fig. 5-6). The power feed for the photocell transmitters (TX) may be connected to terminal <b>11(SC)</b> . Set the parameter <b>AB 02</b> to enable the test function. Each time a command is received, the controller unit switches the photocells off and on to check that the contact changes state correctly. Power feeds for all external devices (excluding the external radio receiver) may be connected to reduce battery consumption (if batteries are used). Set <b>AB 03</b> or <b>AB 04</b> . In the case of installations with two opposed barriers, the functions are not available for the SLAVE barrier. <b>WARNING!</b> If contact <b>11(SC)</b> is used for the photocell test function or battery saving function, a barrier open indicator lamp CANNOT BE connected.
<b>11(+SC)</b> <b>13(COM)</b>	Indicator lamp connection for signalling the ACS/BA/60 detachable boom system sensor anomaly or for signalling battery supply anomaly (battery exhausted). (Fig. 9) The voltage level of the battery can be set via parameter <b>B5</b> .  By connecting a RELAY to the <b>SC</b> output, an error alert signal contact can be achieved at an external control system (fig. 9). <b>NOTE:</b> in MASTER - SLAVE systems, connect the external control system to the <b>SC</b> output of the MASTER control unit (if par. <b>20 = 01, 02, 03</b> ), the SC output of the SLAVE is of type "ON = bar open; OFF = bar closed". If par. <b>20 = 04</b> , the SC output of the SLAVE control unit provides instead an alarm signal relative to the SLAVE barrier.
<b>12(+LIGHTS)</b> <b>13(COM)</b> 	Input for connecting <b>ALED</b> series signal lights on boom (optional). 24 V DC 12W max (fig. 3).
<b>14(+24V)</b> <b>13(COM)</b>	Power feed for external devices, max. 10W. See technical specifications.
<b>15(+ES)</b> <b>17(COM)</b> 	Input for connecting electric lock, 12 Vdc max. 15 W or 5W for electroblock power supply (fig. 3). The function of the electric lock is determined by parameter <b>29</b> . Vmedia=12Vdc, Vmax=40Vdc; see table "PRODUCT TECHNICAL FEATURES" on page 62
<b>16(+LAM)</b> <b>17(COM)</b> 	Connection for flashing light (24 V DC - max. 5 W). The settings for the pre-manoeuve flashing warning signal may be selected with parameter <b>A5</b> , while the flashing mode is set with parameter <b>7B</b> .
<b>18(COM)-19(LNA)-20(LNB)</b> 	RS485 serial communication cable connection (3x0.5 mm <sup>2</sup> - max. length 30 m) for installation of two MASTER / SLAVE opposing barriers (from firmware version <b>n5 13</b> or later).  <b>Connections.</b> <ul style="list-style-type: none"> <li>Connect the <b>COM-LNA-LNB</b> terminals of the MASTER barrier to the relative terminals of the SLAVE barrier.</li> <li>The MASTER barrier is the barrier which opens (completely) when the partial open command (PED) is received.</li> <li>Set parameter <b>AD 11</b> for the MASTER barrier and parameter <b>AD 10</b> for the SLAVE barrier.</li> <li>After having modified the settings of parameter <b>AD</b> shut off power and power up again.</li> <li>All command signals, the photocells and the main STOP command must be connected to the MASTER barrier. The sensing edges and the <b>ACS/BA/60</b> BreakAway devices must be connected to the corresponding barriers.</li> <li>An auxiliary STOP command signal may also be connected to the SLAVE barrier. If not used, jumper terminals <b>21(ST)-22(COM)</b> on the SLAVE controller.</li> <li>All parameters except for <b>AD</b>, <b>19</b> and <b>73</b> must be set on the MASTER controller.</li> <li>The travel acquisition procedure must be performed for both barriers, after setting the parameters as required and in accordance with the type of installation.</li> <li>Alarm messages are viewable on the displays of the respective controllers.</li> </ul>

CONTACT	DESCRIPTION
<p><b>18(COM)-19(LNA)-20(LNB)</b></p> 	<p><b>Function.</b> Serial communication enables synchronised operation of the two barriers. The obstacle detection system immediately reverses the direction of the boom which detected the obstacle, while the other boom reverses after a fixed delay. If the MASTER barrier is completely open or completely closed and the SLAVE barrier is in an intermediate position, the MASTER barrier sends a re-alignment command to the SLAVE barrier, with a 5 second pre-manoeuvre flashing warning signal. Conversely, if the MASTER barrier is in an intermediate position, after 5 seconds of pre-flashing it re-aligns with the SLAVE barrier. The alignment function is disabled if the "operator present" function <b>A7</b> <b>01</b> is enabled.</p>
<p><b>21(ST) 22(COM)</b></p> 	<p>STOP command input (NC). The current manoeuvre is arrested if the safety contact opens. <b>N.B.:</b> the controller is supplied with this contact already jumpered by ROGER TECHNOLOGY. In the case of installations with two opposed barriers, if the STOP command signal is given for the MASTER barrier, both barriers stop. If the STOP command signal is given for the SLAVE barrier, only the SLAVE barrier stops.</p>
<p><b>23(COS) 22(COM)</b></p> 	<p>Input (NC or 8.2 kOhm) for connecting sensing edge <b>COS</b>. Movement is reversed (open) if the sensing edge is activated during closure. If the sensing edge is not installed, jumper the terminals <b>23(COS)-22(COM)</b> or set parameter <b>73 00</b>. In the case of installations with two opposed barriers, the sensing edge (if installed) must be connected to and configured for both the MASTER barrier and the SLAVE barrier.</p>
<p><b>24(FT) 13(COM)</b></p> 	<p>Input (NC) for connecting photocell <b>FT</b> (fig. 4-5-6). The photocells are configured by default with the following settings: - <b>50 00</b>. Photocell triggers only during barrier closure. Photocell is ignored during barrier opening manoeuvre. - <b>51 02</b>. Movement is reversed if the photocell is triggered during barrier closure. - <b>52 01</b>. The barrier opens when an open command is received if the photocell FT is obstructed. If the photocells are not installed, jumper the terminals <b>24(FT) - 25(COM)</b> or set the parameters <b>50 00</b> and <b>51 00</b>. <b>WARNING!</b> Use <b>G90/F4ES</b> or <b>T90/F4S</b> photocells.  In the case of installations with two opposed barriers, the photocells must be connected to and configured for the MASTER barrier only. In the case of installations with parking mode, the input <b>FT</b> may be used to receive a closing command from a magnetic loop (NC) (see chapter 14).</p>
<p><b>27 26(ANT)</b></p> 	<p>Antenna connector for slot-in radio receiver board. Use RG58 if an external antenna is used - maximum recommended length: 10 m. <b>N.B.:</b> do not make joints in cable.</p>
<p><b>29(PED) 28(COM)</b></p> 	<p>Partial open command input (NO). The barrier is always opened completely when the contact is closed. In the case of installations with two opposed barriers, the command PED only opens the MASTER barrier when both barriers are completely closed. In the case of installations with "Directional" parking mode (parameter <b>B3 02</b> or <b>B3 03</b>), the input PED may be used to receive a closing command from a magnetic loop (NC) (see chapter 14).</p>
<p><b>29(PED) 28(COM)</b></p> 	<p>The command input (N.C.) available for the connection of the sensor of the <b>ACS/BA/60</b> detachable barrier boom coupling system (fig. 8) When the <b>ACS/BA/60</b> detachable boom safety system intervenes, the contact switches from N.C. to N.O. Enable the contact via parameter <b>19 04</b>.</p>
<p><b>30(PP) 28(COM)</b></p> 	<p>Step mode command input (NO). The function of this command is determined by parameter <b>A4</b>.</p>
<p><b>30(PP) 28(COM)</b></p> 	<p>The command input (N.C.) available for the connection of the sensor of the <b>ACS/BA/60</b> detachable barrier boom coupling system (fig. 8) When the <b>ACS/BA/60</b> detachable boom safety system intervenes, the contact switches from N.C. to N.O. Enable the contact via parameter <b>19 03</b>.</p>
<p><b>31(CH) 28(COM)</b></p> 	<p>Close command input (NO).</p>
<p><b>31(CH) 28(COM)</b></p> 	<p>The command input (N.C.) available for the connection of the sensor of the <b>ACS/BA/60</b> detachable barrier boom coupling system (fig. 8) When the <b>ACS/BA/60</b> detachable boom safety system intervenes, the contact switches from N.C. to N.O. Enable the contact via parameter <b>19 02</b>.</p>

CONTACT	DESCRIPTION
<b>32(AP) 28(COM)</b> 	Open command input (NO).
<b>32(AP) 28(COM)</b> 	The command input (N.C.) available for the connection of the sensor of the <b>ACS/BA/60</b> detachable barrier boom coupling system (fig. 8) When the <b>ACS/BA/60</b> detachable boom safety system intervenes, the contact switches from N.C. to N.O. Enable the contact via parameter <b>19 01</b> .
<b>33(ORO) 34(COM)</b> 	Clock timer contact input (N.O.). When the clock function is active, the barrier opens and remains open. At the end of the programmed time set with the external device (clock) the barrier closes. The function of this command is determined by parameter <b>BQ</b> .
<b>33(ORO) 34(COM)</b> 	The command input (N.C.) available for the connection of the sensor of the <b>ACS/BA/60</b> detachable barrier boom coupling system (fig. 8) When the <b>ACS/BA/60</b> detachable boom safety system intervenes, the contact switches from N.C. to N.O. Enable the contact via parameter <b>19 05</b> . For systems composed of two MASTER and SLAVE opposing barriers, connect the detachable boom coupling system sensor of the SLAVE barrier <b>STRICTLY</b> to the <b>ORO</b> input of the SLAVE control unit.
<b>ENC1</b>	7-way connector for connecting to encoder installed on motor (see fig. 12-13). <b>WARNING!</b> Always disconnect from electrical power before disconnecting or connecting the encoder cable.
<b>ENC2</b>	6-way connector for connecting to encoder installed on one side of motor (see fig. 12-13). <b>WARNING!</b> Always disconnect from electrical power before disconnecting or connecting the encoder cable.
<b>LED LIGHT</b>	Connector for the (OPTIONAL) <b>B73/EXP</b> signal device connection and flashing lights installed on the top cover (see fig. 14-15).
<b>LOCKS</b>	Connectors for connecting lock device microswitch and safety stop microswitch on barrier inspection hatch (connection not supplied by ROGER TECHNOLOGY) (see fig. 10-11). Jumper the other connector if only one connector is connected.
<b>RECEIVER CARD</b>	Connector for slot-in radio receiver board. The controller has two radio remote control functions by default: – PR1 - step mode command (modifiable with parameter 76). – PR2 - close command (modifiable with parameter 77).
<b>B71/BCHP BI/BCHP BATTERY CHARGER</b>  <b>BI/BAT/KIT BATTERY KIT</b> 2x12 Vdc 4.5 Ah (AGM type ONLY)	Connector for slot-in battery charger board. In the event of a mains power loss, the controller unit is powered by the batteries. When battery power is used, the message <b>bAtE</b> is shown on the display and the flashing light flashes briefly at intervals until mains power is restored or until the battery voltage drops below the minimum permissible limit. In this case, <b>bELQ</b> (Battery Low) is shown on the display and the controller unit accepts no commands. If mains power is lost while the boom is moving, the boom stops and then automatically resumes the interrupted manoeuvre after 2 seconds. By setting parameter <b>B5</b> to a value different than <b>00</b> , the battery management is enabled. With parameter <b>B5</b> the battery operation limitation type is enabled when the voltage drops under a certain threshold. Parameter <b>B5</b> is not available for SLAVE automation systems. <b>WARNING!</b> the batteries must always be connected to the electronic controller unit in order to charge. Periodically (at least every 6 months), check that the batteries are in good working order.  For more information, refer to the installation manual for the <b>B71/BCHP</b> or <b>BI/BCHP</b> battery charger.

## 8 Function buttons and display

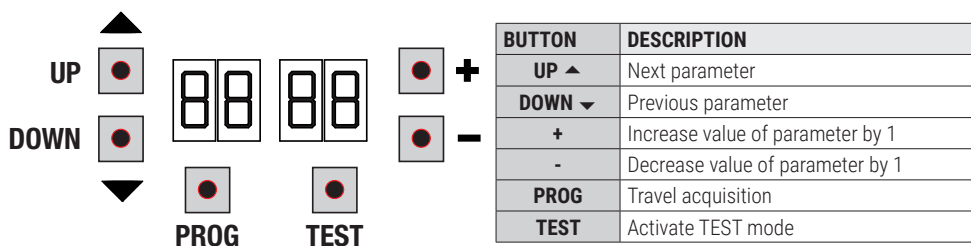

- Press the UP ▲ and/or DOWN ▼ buttons to view the parameter you intend to modify.
- Use the + and - buttons to modify the value of the parameter. The value starts to flash.
- Press and hold the + or - button to scroll quickly through values, to modify the parameter more quickly.
- To save the new value, wait a few seconds or move onto another parameter with the UP ▲ or DOWN ▼ button. The display flashes rapidly to indicate that the new value has been saved.
- Parameters can only be modified while the motor is not running. Parameters can be viewed at any time.

## 9 Switching on or commissioning

Power the control unit.

The firmware version of the control unit is displayed briefly.

Version installed P4.10.



Immediately afterwards, the displays enter the commands and safety device status mode. See chapter 10.

Now set up the installation by configuring the parameters as needed.

For installations with two opposing barriers, settings must be made from the MASTER controller. Only the parameters **A0** and **T3** may be modified from the SLAVE controller.

## 10 Display function modes

### 10.1 Parameter display mode

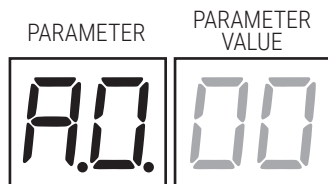

See chapter 12 for detailed descriptions of parameters.

## 10.2 Command and safety device status display mode

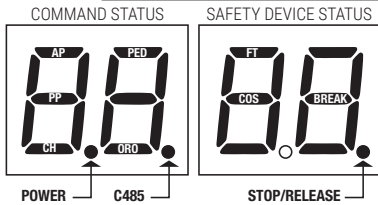

### COMMAND STATUS:

The command status indicators on the display (segments AP = open, PP = step mode, CH = close, PED = partial opening, ORO=clock) are normally off. They illuminate when a command is received (e.g.: when a step mode command is received, the segment PP illuminates).

### SAFETY DEVICE STATUS:

The safety device status indicators on the display (segments FT = photocells, COS = sensing edge, BREAK= BreakAway system **ACS/BA/60** magnetic sensor or STOP/RELEASE position) are normally on.

If an indicator is off, the relative device is in alarm state or is not connected. The an indicator is flashing, the relative device has been disabled with a specific parameter.

## 10.3 TEST mode

The TEST mode is used to test activation of the commands and safety devices with visual confirmation.

To activate the mode, press the TEST button with the automatic barrier system at rest. If the barrier is moving, pressing TEST stops the barrier. Pressing the button again enables TEST mode.

The flashing light and the barrier open indicator lamp illuminate for one second.

N.B.: For installations with two opposing barriers, if the TEST button is pressed for the SLAVE barrier, the MASTER barrier continues to function normally.

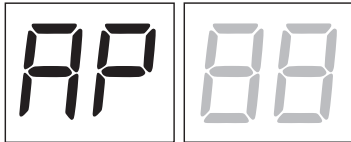

The command signal status is shown on the left hand side of the display for 5 seconds, ONLY when the respective command signal is active (AP, CH, PP, PE, OR).

For example, if the open command is activated, the letters AP appear on the display.

The status of the safety devices/inputs is shown on the right hand side of the display. The number of the terminal relative to the safety device in alarm state flashes.

Example: STOP contact in alarm state.

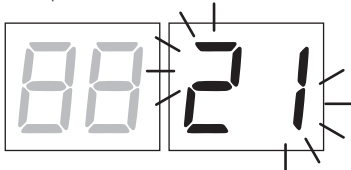

00	No safety device in alarm state or barrier waiting for command.
21	STOP contact (N.C.) open. Jumper the STOP contact. Release handle or lock open. Barrier inspection hatch open.
23	Sensing edge contact COS (N.C.) is open. Check connection. If sensing edge is not installed, disable with 7300.
24	Photocell contact FT (N.C.) is open (message shown on MASTER controller displayed). Check connection. If photocell is not installed, disable with 5000.
br	Shatter-proof system enabled, or not connected or incorrectly connected.
r5 (rS)	STOP contact active for MASTER barrier (message shown on SLAVE controller displayed).

**N.B.:** If one or more contacts are open, the barrier will neither open nor close.

If more than one safety device is in alarm state, once the problem relative to the first device is resolved, the alarm for the next device is displayed. Any further alarm states are also displayed with the same logic.

Press the TEST button again to exit test mode.

After 10 seconds with no user input, the display returns to command and safety device state display mode.

## 10.4 Standby mode

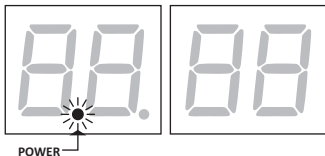

This mode is activated after 30 minutes with no user input. The POWER LED flashes slowly.

Press UP ▲, DOWN ▼, + or - to reactivate the control unit.

# 11 Travel acquisition

**i** For the system to function correctly, the barrier travel must be acquired by the controller.

## 11.1 Before starting:

**IMPORTANT: Select the length of the boom with the parameter *R 1*.**



It is very important that this parameter is selected correctly. An incorrect setting may cause severe damage or injury.

SELECTION	MODEL	BOOM
<i>R 1 00</i>	AG/004 KB/004 BI/004HP	up to 3 m
<i>R 1 01</i>	AG/004 KB/004 BI/004HP	from 3 m to 4,5 m
<i>R 1 02</i>	AG/006 KB/006 BI/006	from 4,5 to 6 m
<i>R 1 03</i>	BI/004	up to 3 m
<i>R 1 04</i>	BI/004	from 3 m to 4 m
<i>R 1 05</i>	BI/008	up to 8 m

1. Select the position of the barrier in relation to the gate, using parameter *7 1*. The factory setting of the parameter is with the barrier installed on the right (*7 1 0 1*) and the boom opening/closure gate on the left (seen from the inspection hatch side).

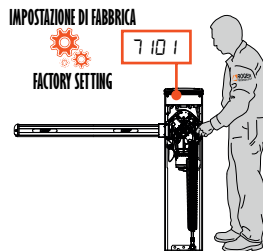
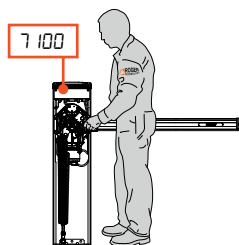

If the installation position is changed from the right to the left, the position of the spring(s) must also be changed.



For the correct installation, refer to the barrier installation manual.



**i IMPORTANT! Lubricate the pivot points with lithium based grease (EP LITIO)**

2. Check that the "operator present" function is not enabled (A7 00).

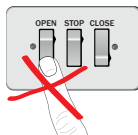

3. Check the spring balance setting and the mechanical stop settings.



For further information, refer to the installation manual of the barrier.

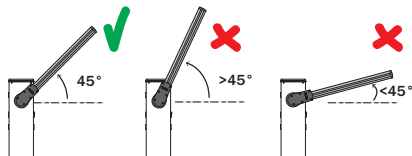

**i IMPORTANT! Lubricate the pivot points with lithium based grease (EP LITIO)**

4. For installations with opposed barriers, connect the command signals and safety devices to the MASTER controller. See chapter 7 for further information on installation (see fig. 20).

5. If the ACS/BA/60 detachable boom coupling system is not installed, the parameter 19 must be set to 00.

**6. Move the barrier boom into the completely CLOSED position.**

7. Press TEST (see TEST mode in paragraph 10.3) and check the command signal and safety device states. If the safety devices are not installed, jumper the contact or disable safety device function from the relative parameter (50, 51 and 73).

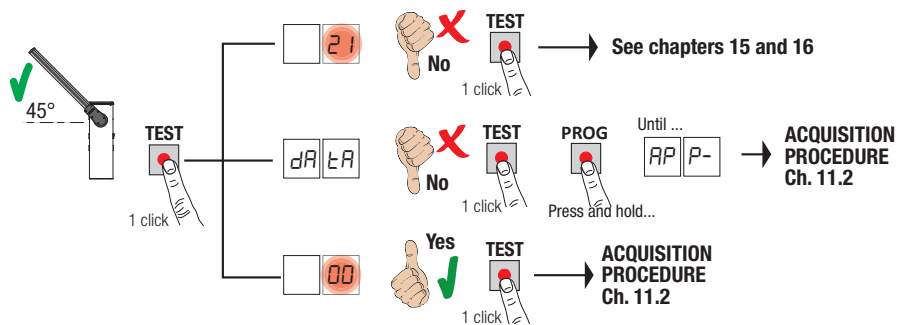

## 11.2 STANDARD (STAND ALONE) acquisition procedure:

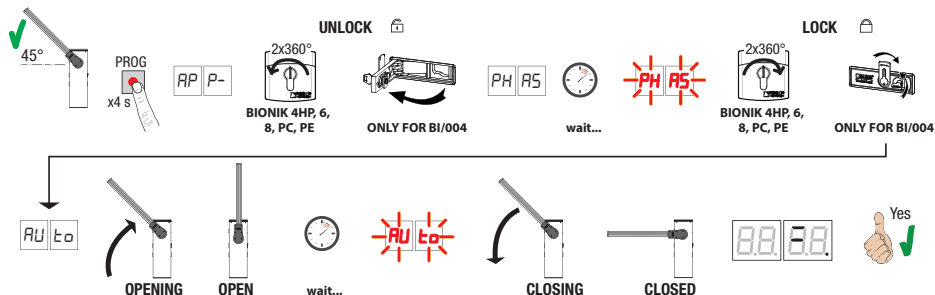

• Press and hold PROG for 4 seconds. AP P- is shown on the display.

- Unlock the barrier.  
**AGILIK-KB-BIONIK4HP-BIONIK6-BIONIK8**. Turn the key anticlockwise by two full turns.  
**BIONIK4**. Open the release cover.
  - The barrier goes to 45° degree.
  - After a few seconds, the message *PH RS* is shown on the display. The controller unit launches a calibration procedure. The operating parameters of the motor are determined during calibration.
  - If the motor calibration procedure is successful, the message *PH RS* flashes on the display.
  - To lock the barrier again  
**AGILIK-KB-BIONIK4HP-BIONIK6-BIONIK8**. Turn the key clockwise by two full turns.  
**BIONIK4**. Close the release cover and turn the key.
  - The acquisition procedure now starts. The message *RUŁ* is shown on the display and the barrier starts opening at low speed.
  - Once the barrier open mechanical stop is reached, the barrier stops briefly. The message *RUŁ* flashes on the display.
  - The barrier closes until it reaches the barrier closed mechanical stop.
- If the acquisition procedure is completed successfully, the display enters the command and safety device state display mode.
- If the following error messages are shown on the display, repeat the acquisition procedure:
- *PH*: calibration procedure failed.
  - *AP P.E*: acquisition error.

**i** For more information, see chapter 16 "Alarms and faults".

### 11.3 MASTER/SLAVE acquisition procedure:

1. Check the spring balance setting and the mechanical stop settings.



For further information, refer to the installation manual of the barrier.

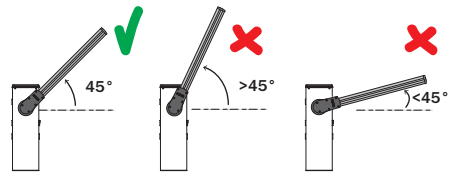

2. With both control units not powered (and with battery disconnected, if present), make the bus connections on the MASTER and SLAVE control units (see fig. 20).

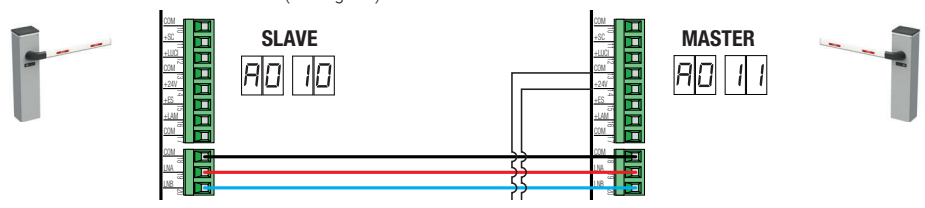

3. Enable RS485 serial communication (**MASTER**): *A0 11*
4. Enable RS485 serial communication (**SLAVE**): *A0 10*
5. Select the position of the barrier in relation to the gate, using parameter *7 1*. The factory setting of the parameter is with the barrier installed on the right (*7 10 1*) and the boom opening/closure gate on the left (seen from the inspection hatch side). The position of the SLAVE barrier is automatically set to complementary.

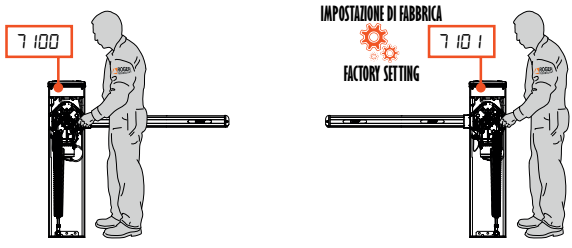



If the installation position is changed from the right to the left, the position of the spring(s) must also be changed.

## 6. MASTER acquisition procedure:

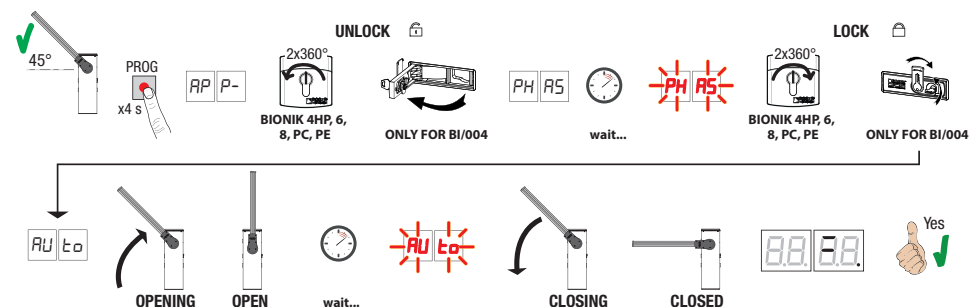

- Press and hold PROG for 4 seconds. *AP P-* is shown on the display.
- Unlock the barrier.

**AGILIK-KB-BIONIK4HP-BIONIK6-BIONIK8.** Turn the key anticlockwise by two full turns.  
**BIONIK4.** Open the release cover.

- The barrier goes to 45° degree.
- After a few seconds, the message *PH RS* is shown on the display. The controller unit launches a calibration procedure. The operating parameters of the motor are determined during calibration.
- If the motor calibration procedure is successful, the message *PH RS* flashes on the display.
- To lock the barrier again

**AGILIK-KB-BIONIK4HP-BIONIK6-BIONIK8.** Turn the key clockwise by two full turns.  
**BIONIK4.** Close the release cover and turn the key.

- The acquisition procedure now starts. The message *RU L0* is shown on the display and the barrier starts opening at low speed.
  - Once the barrier open mechanical stop is reached, the barrier stops briefly. The message *RU L0* flashes on the display.
  - The barrier closes until it reaches the barrier closed mechanical stop.
- If the acquisition procedure is completed successfully, the display enters the command and safety device state display mode.

If the following error messages are shown on the display, repeat the acquisition procedure:

- *PH*: calibration procedure failed.
- *AP P.E*: acquisition error.



**For more information, see chapter 16 “Alarms and faults”.**

## 7. SLAVE acquisition procedure:

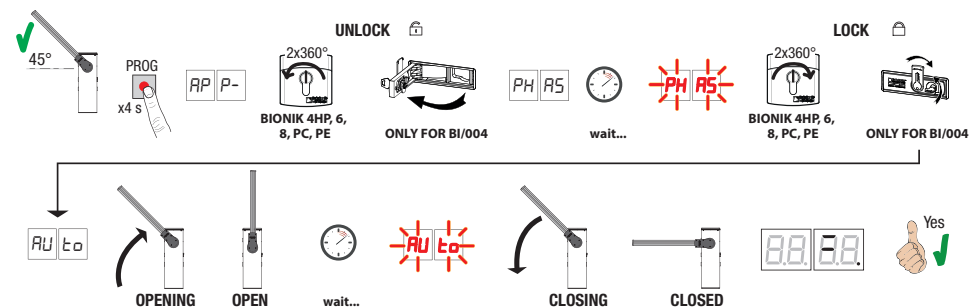

- Press and hold PROG for 4 seconds. *AP P-* is shown on the display.
- Unlock the barrier.

**AGILIK-KB-BIONIK4HP-BIONIK6-BIONIK8.** Turn the key anticlockwise by two full turns.  
**BIONIK4.** Open the release cover.

- The barrier goes to 45° degree.
- After a few seconds, the message *PH RS* is shown on the display. The controller unit launches a calibration procedure. The operating parameters of the motor are determined during calibration.

- If the motor calibration procedure is successful, the message *PH R5* flashes on the display.
  - To lock the barrier again  
**AGILIK-KB-BIONIK4HP-BIONIK6-BIONIK8**. Turn the key clockwise by two full turns.  
**BIONIK4**. Close the release cover and turn the key.
  - The acquisition procedure now starts. The message *RUE* is shown on the display and the barrier starts opening at low speed.
  - Once the barrier open mechanical stop is reached, the barrier stops briefly. The message *RUE* flashes on the display.
  - The barrier closes until it reaches the barrier closed mechanical stop.
- If the acquisition procedure is completed successfully, the display enters the command and safety device state display mode.

If the following error messages are shown on the display, repeat the acquisition procedure:

- *r* *PH*: calibration procedure failed.
- *RP P.E*: acquisition error.



**For more information, see chapter 16 "Alarms and faults".**



**The correct self-learning procedure of the barrier in STANDARD and MASTER/SLAVE mode requires that the first operation of the barrier is always from 45° towards opening. In case the first operation is from 45° towards closing, check again the correct position of the barrier opening and then set again the value of parameter 7 I.**



**For connection and wiring operation consider:**

- **Wiring mains power cable to the MASTER barrier**
- **RS485 bus connection wiring: check the correspondence of the cables that must connect the LNA MASTER terminal with the LNA SLAVE terminal, similarly for the LNB MASTER and SLAVE terminals**
- **Always check that the ST (STOP) and COM inputs are jumpered (if no STOP button is installed, N.C. contact)**
- **the parameters concerning the functionality of the central unit are managed exclusively by the MASTER central unit which automatically passes them to the SLAVE central unit. Only parameters R0, 19, 3 I and 7 B must be set on the SLAVE control unit**

# 12 Index of parameters

PARAM.	FACTORY DEFAULT	DESCRIPTION	PAGE
A0	00	Enable RS485 serial communication (MASTER-SLAVE)	82
A1	02	Barrier model and the length of the boom selection	82
A2	00	Automatic closing after time pause (from barrier completely open position)	82
A3	00	Automatic closing after mains power outage	83
A4	00	Step mode control function selection (PP)	83
A5	00	Pre-manoeuve flashing warning	83
A6	00	Condominium function for partial open command (PED)	83
A7	00	Enable "operator present" function	83
A8	00	Barrier open/photocell test function and battery saving mode indicator lamp	83
10	00	Enable the <b>B73/EXP</b> signal device to indicate barrier completely open/closed positions	83
11	10	Setting deceleration during opening	83
12	10	Setting deceleration during closure	84
19	00	"BreakAway" <b>ACS/BA/60</b> detachable boom coupling system enabling	84
20	00	SC output operating mode	84
21	30	Setting automatic closing time	84
22	00	Enabling of management for opening with automatic re-closure exclusion	84
29	00	Enable electric lock	84
31	09	Obstacle detection time setting (crush prevention)	85
33	10	Setting opening start acceleration	85
34	10	Setting closure start acceleration	85
40	04	Opening speed setting	85
41	04	Closure speed setting	85
42	01	Approach speed setting	85
43	15	Opening approach distance setting	85
44	30	Closing approach distance setting	85
49	01	Number of automatic closure attempts after activation of sensing edge or obstacle detection (crush protection)	85
50	00	Photocell mode for barrier opening (FT)	85
51	02	Photocell mode for barrier closure (FT)	85
52	01	Photocell (FT) mode with barrier closed	86
56	00	Enable close command 6 s after activation of photocell (FT)	86
65	08	Motor stop distance setting	86
71	01	Installation position of barrier relative to gateway (seen from the inspection hatch side).	86
73	00	Sensing edge COS configuration	86
76	00	Radio channel 1 configuration (PR1)	86
77	03	Radio channel 2 configuration (PR2)	86
78	02	Flashing light / upper cover lights frequency configuration	86

PARAM.	FACTORY DEFAULT	DESCRIPTION	PAGE
79	00	Operating mode of signal lights on boom	87
80	00	Clock contact configuration	87
81	00	Enable safeguarded barrier closure	87
82	03	Safeguarded closure activation time setting	87
83	00	Parking access mode selection	87
84	00	Enable close command after photocell activation (FT)	88
85	00	Selection of the battery operation management	88
86	00	Selection of the battery operation limitations	88
87	00	Selection of the battery type and consumption reduction	88
90	00	Restoring factory default values	88
n0	01	HW version	89
n1	23	Year of manufacture	89
n2	45	Week of manufacture	89
n3	67	Serial number	89
n4	89		89
n5	01		89
n6	23		FW version
n7	45	RS485 serial communication version	89
o7	01	Manoeuvres performed	89
o0	23		89
o1	45		89
h0	01	Manoeuvre hours	89
h1	23		89
d0	01	Days with unit switched on	89
d1	23		89
P1	00	Password	89
P2	00		89
P3	00		89
P4	00		89
CP	00	Password change protection	89

# 13 Parameters menu

PARAMETER

PARAMETER  
VALUE

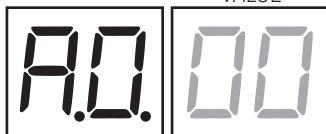

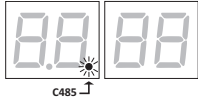
<b>A0 00</b>	<b>Enable RS485 serial communication (MASTER-SLAVE)</b> Enabling serial communication permits the synchronised control of two opposing automation systems. <b>Example:</b> a command signal received by MASTER automation system also opens the SLAVE automation system.
00	Disabled.
10	SLAVE automation system.
11	MASTER automation system. When the MASTER automation is enabled, the message <i>SrCH</i> illuminates on the display for a few seconds. If the SLAVE automation system is detected correctly, C485 illuminates. 

<b>A1 02</b>	<b>Barrier model and the length of the boom selection</b> <b>WARNING! An incorrect setting may cause severe damage or injury.</b> Use the standard parameter values indicated in the table in relation to the boom length selected.	
		<b>Parameter</b>
		11 12 31 33 34 40 41 43 44 65
00	<b>AG/004</b> <b>KB/004</b> <b>BI/004HP</b>	boom up to 3 m
01	<b>AG/004</b> <b>KB/004</b> <b>BI/004HP</b>	boom from 3 m to 4.5 m
02	<b>AG/006</b> <b>KB/006</b> <b>BI/006</b>	boom from 4.5 m to 6 m
03	<b>BI/004</b>	boom up to 3 m
04	<b>BI/004</b>	boom from 3 m or 4 m
05	<b>BI/008</b>	boom up to 8 m
	<b>STANDARD VALUE</b>	
		08 06 07 05 07 07 07 10 10 04
		09 09 08 06 08 06 05 10 10 06
		10 10 09 10 10 04 04 15 30 08
		08 06 07 05 07 07 07 10 10 04
		09 09 08 06 08 06 05 10 10 06
		10 10 09 10 10 04 04 15 30 08

<b>A2 00</b>	<b>Automatic closing after time pause (from barrier completely open position)</b> <b>N.B.:</b> This parameter is not visible for the SLAVE barrier, and if the value of parameter <b>B3</b> = 01, 02 or 03.
00	Disabled.
01-15	From 1 a 15 automatic closure attempts after activation of photocells. Once the number of attempts set is reached, the barrier remains open.
99	The barrier tries to close indefinitely.

<b>A3 00</b>	<b>Automatic closing after mains power outage</b> <b>N.B.:</b> This parameter is not visible for the SLAVE barrier.
00	Disabled. The barrier does NOT close automatically when mains power is restored.
01	Enabled. If the barrier is NOT completely open, when mains power is restored, the barrier closes after a 5 second pre-manoeuve warning signalled with the flashing light (independently of the value set with parameter <b>A5</b> ).

<b>R4 00 Step mode control function selection (PP)</b>	
00	Open-stop-close-stop-open-stop-close...
01	Condominium function: the barrier opens and closes after the set automatic closing time. The automatic closing timer restarts if a new step mode command is received with the boom in the completely open position. Step mode commands are ignored while the barrier is opening. This allows the boom to open completely and prevents unintentional closing. If automatic closing is disabled (R2 00), the condominium function automatically attempts a closing manoeuvre R2 01
02	Condominium function: the barrier opens and closes after the set automatic closing time. The automatic closing timer does NOT restart if a new step mode command is received. Step mode commands are ignored while the barrier is opening. This allows the boom to open completely and prevents unintentional closing. If automatic closing is disabled (R2 00), the condominium function automatically attempts a closing manoeuvre R2 01
03	Open-close-open-close.
04	Open-close-stop-open.
<b>R5 00 Pre-manoeuve flashing warning</b>	
00	Disabled. The flashing light is activated during opening and closing manoeuvres.
01-10	Flashing warning signal for 1 to 10 seconds prior to every manoeuvre.
99	5 second flashing warning signal prior to closing manoeuvre.
<b>R6 00 Condominium function for partial open command (PED)</b>	
00	Disabled. The barrier opens partially in step mode: open-stop-close-stop-open...
01	Enabled. Partial open commands (PED) are ignored during barrier opening.
<b>R7 00 Enable "operator present" function</b> N.B.: this parameter is not visible if the value of parameter B3 = 01, 02 or 03.	
00	Disabled.
01	Enabled. The open (AP) or close (CH) button must be pressed continuously to operate the barrier. The boom stops when the button is released.
<b>R8 00 Barrier open/photocell test function and battery saving mode indicator lamp</b> N.B.: This parameter is not visible for the SLAVE barrier, (which has a non-modifiable setting of 00) or if the parameter 20 is other than 00.	
00	The indicator is off when the barrier is closed, and steadily lit during manoeuvres and when the barrier is open.
01	The indicator flashes slowly during opening manoeuvres, and is lit steadily when the barrier is completely open. Flashing rapidly during closing manoeuvres. If the barrier is stopped in an intermediate position, the lamp extinguishes twice every 15 s.
02	Set to 02 if the output SC is used for the photocell test. See fig. 5.
03	Set to 03 if the output SC is used for the "battery saving" function. See fig. 6. When the barrier is completely open or closed, the controller unit deactivates any accessories connected to terminal SC to reduce battery consumption. N.B.: setting not available for installations with two opposing barriers. This value is not visible if the value of parameter B3 = 01, 02, 03 or A0 = 10, 11.
04	Set to 04 if the output SC is used for the "battery saving" function and photocell test function. See fig. 6. N.B.: setting not available for installations with two opposing barriers. This value is not visible if the value of parameter B3 = 01, 02 or 03 or A0 = 10, 11.
<b>10 00 Enable the B73/EXP signal device to indicate barrier completely open/closed positions (NC potential free contact)</b>	
00	Disabled.
01	Enabled. When the boom is completely open, contact TO (NC) opens and the green LED illuminates on the B73/EXP board. When the boom is completely closed, contact TC (NC) opens and the red LED illuminates on the B73/EXP board.
<b>11 10 Setting deceleration during opening</b>	



<b>12 10</b>	<b>Setting deceleration during closure</b>
01-10	01= barrier decelerates near stop ... 10= barrier decelerates long before reaching the stop. <b>N.B.:</b> Available values may be limited by the setting for parameter <i>A1</i> .
<b>19 00</b>	<b>"BreakAway" ACS/BA/60 shatter-proof system enabling (fig. 8)</b> Connect the shatter-proof system sensor to one of the control inputs on the control unit. When the shatter-proof system is triggered, the signal switches from N.C. to N.O. For systems composed of opposing MASTER and SLAVE barriers, disconnect the sensor in the SLAVE barrier STRICTLY on the ORO input of the SLAVE control unit and set the parameter <i>19 05</i> .
00	If NOT connected, all control inputs will have standard function.
01	Connected on AP input
02	Connected on CH input
03	Connected on PP input
04	Connected on PED input
05	Connected on ORO input. (For SLAVE barrier: use ONLY for this setting).
<b>20 00</b>	<b>SC output operating mode (fig. 9)</b> By connecting a Relay to the <b>SC</b> output, an error alert contact can be achieved at an external control system. For systems composed of opposing MASTER and SLAVE barriers, perform the connections on the MASTER control unit. For values 00, 01, 02, 03 the <b>SC</b> output on the SLAVE control unit has standard function set via parameter <i>AB00</i> : the indicator is off when the barrier is closed, and steadily lit during manoeuvres and when the barrier is open. For the value 04, the <b>SC</b> output of the SLAVE provides the alarm status of the SLAVE.
00	STANDARD operation managed by parameter <i>AB</i>
01	With the indicator lamp connected to the <b>SC</b> output and if lit, it indicates that the shatter-proof system sensor <b>ACS/BA/60</b> is in stand-by. Indicator light off due to an anomaly: sensor alarm.
02	With the indicator lamp connected to the <b>SC</b> output and if lit, it indicates that the barrier is powered by the mains source or by a charged battery. Indicator light off due to an anomaly: the battery is exhausted (voltage level set via parameter <i>B5</i> ).
03	With the indicator lamp connected to the <b>SC</b> output and if lit, it indicates that none of the abnormal situations 1 or 2 occurred. With the indicator lamp off it indicates that at least one of the abnormal situations 1 or 2 has occurred.
04	With the indicator lamp connected to the <b>SC</b> output and if lit, it indicates that the barrier is working. With the indicator lamp off, it indicates that the barrier is blocked for an alarm or for operation STOP/BLOCK/SENSOR <b>ACS/BA/60</b> or for the activation of an alarm or for "bE L D" signalling on the display. NOTE: in case of MASTER/SLAVE operation both barriers have signalling independent
<b>21 30</b>	<b>Setting automatic closing time</b> The timer starts from the barrier open state and continues for the set time. Once the set time is reached, the barrier closes automatically. The timer count restarts if a photocell is triggered.
00-90	pause time settable from 00 to 90 s.
92-99	pause time settable from 2 to 9 min.
<b>22 00</b>	<b>Enabling of management for opening with automatic re-closure exclusion</b> If enabled, the exclusion of automatic re-closure only applies for the command selected via the parameter. For example: if you set <i>220 1</i> , automatic re-closure is excluded following an <b>AP</b> command, but it is activated following a <b>PP</b> or <b>PED</b> command. <b>NOTE:</b> The command has open-stop-close or close-stop-open sequence activation function. <b>NOTE:</b> The parameter is not visible if par. <i>A0</i> or <i>B3</i> is different than 00
00	Disabled.
01	An <b>AP</b> (open) command activates the opening manoeuvre. With the barrier fully open, automatic re-closure is excluded. Another <b>AP</b> (open) command activates the closure manoeuvre.
02	A <b>PP</b> (step mode) command activates the opening manoeuvre. With the barrier fully open, automatic re-closure is excluded. Another <b>PP</b> (step mode) command activates the closure manoeuvre.
03	A <b>PED</b> (partial opening) command activates the partial opening manoeuvre. Automatic re-closure is excluded. Another <b>PED</b> (partial opening) command activates the closure manoeuvre.
<b>29 00</b>	<b>Enable electric block</b>
00	Disabled.

01	Normally not powered. The electric lock is powered for 1,5 s at the start of the opening manoeuvre to allow the barrier to open.
02	Magnetic "ventouse" electric lock normally powered when the barrier is completely closed. Not powered when the barrier is moving or completely open
03	Magnetic "ventouse" type electroblock with demagnetizer <b>B72/DGS</b> <b>NOTE:</b> In the case of <b>MASTER/SLAVE</b> installation, in order to use the selection par. 29 = 03 it is necessary that both control units have firmware P4.10 (or later).
<b>3109</b>	<b>Obstacle detection function setting (crush prevention)</b> The barrier reopens if the obstacle detection system is activated during a closing manoeuvre. During opening manoeuvres, the barrier is reversed by the obstacle detection system only if the obstacle is detected within the first 60° of the manoeuvre. The maximum number of automatic closing attempts is set by parameter 49. <b>N.B.:</b> Available values may be limited by the setting for parameter A 1.
01-09	01= minimum activation time (maximum sensitivity)... 09= maximum activation time (minimum sensitivity).
10	The barrier remains stationary against the obstacle for a maximum time of 5 s before reversing.
<b>3310</b>	<b>Setting opening start acceleration</b>
<b>3410</b>	<b>Setting closure start acceleration</b>
01-10	01= the barrier accelerates rapidly at start of manoeuvre ... 10= the barrier accelerates slowly and progressively at start of manoeuvre. <b>N.B.:</b> Available values may be limited by the setting for parameter A 1.
<b>4004</b>	<b>Setting opening speed (%)</b>
<b>4104</b>	<b>Setting closure speed (%)</b>
01-10	01= 10% minimum speed ... 10= 100% maximum speed. <b>N.B.:</b> Available values may be limited by the setting for parameter A 1.
<b>4201</b>	<b>Approach speed setting</b> This parameter sets the motor speed when approaching the barrier open/closed stop.
01-10	01= 10 motor revolutions per minute (RPM) ... 10= 100 motor revolutions per minute (RPM).
<b>4315</b>	<b>Opening approach distance setting</b>
<b>4430</b>	<b>Closing approach distance setting</b>
05-30	from 0,5 to 3 of turns performed by the motor at speed set with parameter 42. <b>N.B.:</b> Available values may be limited by the setting for parameter A 1.
<b>4901</b>	<b>Number of automatic closure attempts after activation of sensing edge or obstacle detection (crush protection)</b>
00	No automatic closure attempts.
01-03	From 1 to 3 automatic closure attempts. Automatic closure is only performed if the barrier is completely open. Set a value equal to or lower than the value set for parameter A2.
<b>5000</b>	<b>Photocell mode for barrier opening (FT)</b> <b>N.B.:</b> this parameter is not visible if the value of parameter B3 = 01, 02 or 03.
00	DISABLED. Photocell is not active or not installed.
01	STOP. The barrier stops and remains stationary until the next command is received.
02	IMMEDIATE REVERSE. The barrier reverses immediately if the photocell is activated during opening manoeuvre.
03	TEMPORARY STOP. The barrier stops and remains stationary as long as the photocell is obstructed. The barrier resumes opening when the photocell is cleared.
04	DELAYED REVERSE. The barrier stops if the photocell is obstructed. The barrier closes when the photocell is cleared.
<b>5102</b>	<b>Photocell mode for barrier closure (FT)</b> <b>N.B.:</b> this parameter is not visible if the value of parameter B3 = 01, 02 or 03.
00	DISABLED. Photocell is not active or not installed.
01	STOP. The barrier stops and remains stationary until the next command is received.

02	IMMEDIATE REVERSE. The barrier reverses immediately if the photocell is activated during closing manoeuvre.
03	TEMPORARY STOP. The barrier stops and remains stationary as long as the photocell is obstructed. The barrier resumes closing when the photocell is cleared.
04	DELAYED REVERSE. The barrier stops if the photocell is obstructed. The barrier opens when the photocell is cleared.
<b>52 01</b>	<b>Photocell (FT) mode with barrier closed</b> <b>N.B.:</b> this parameter is not visible if the value of parameter <i>B3</i> = 0 1, 02 or 03 or if <i>AB</i> = 0 1, 02, 03 or 04.
00	If the photocell is obstructed, the barrier cannot open.
0 1	The barrier opens when an open command is received, even if the photocell is obstructed.
02	The photocell sends the barrier open command when obstructed.
<b>56 00</b>	<b>Enable close command 6 s after activation of photocell (FT)</b> <b>N.B.:</b> This parameter is not visible if <i>AB</i> 03 or <i>AB</i> 04 is set, and if value of parameter <i>B3</i> = 0 1, 02 or 03.
00	Disabled.
0 1	Enabled. When the photocell barrier FT is crossed, a close command is sent 6 seconds later.
<b>65 08</b>	<b>Motor stop distance setting</b> The motor brake function is activated each time a stop is requested by a user command or by activation of the photocells. Set a value that will prevent collision with objects or persons due to the inertia of the boom.
0 1- 10	01= rapid braking/smaller stopping distance ... 10= gentle braking (soft-stop)/greater stopping distance ( <b>NOTE:</b> recommended setting for bars longer than 4 m). <b>N.B.:</b> Available values may be limited by the setting for parameter <i>A 1</i> .
<b>71 01</b>	<b>Installation position of barrier relative to gateway (seen from interior side)</b> For installations with two opposed barriers, this setting must be made for the MASTER barrier. The SLAVE barrier recognises its position automatically. <b>N.B.:</b> every time the installation position is changed by altering parameter 7 1, the display shows a position data request message <i>dRtR</i> . Press the <b>PROG</b> key until <i>RPp-</i> appears on the display, then repeat the acquisition procedure (see fig. 21 and chapter 11.2).
00	Barrier installed on the left, viewed from the inspection cover side. With passage opening on the right.
0 1	Barrier installed on the right, viewed from the inspection cover side. With passage opening on the left.
<b>73 00</b>	<b>Sensing edge COS configuration</b>
00	Sensing edge NOT INSTALLED.
0 1	NC contact (normally closed). The barrier reverses only when closing.
02	Contact with 8k2 resistor. The barrier reverses only when closing.
<b>76 00</b>	<b>Radio channel 1 configuration (PR1)</b>
<b>77 03</b>	<b>Radio channel 2 configuration (PR2)</b>
00	STEP MODE.
0 1	PARTIAL OPENING.
02	OPENING.
03	CLOSING.
04	STOP.
07	STEP MODE with confirmation for safety <sup>(1)</sup> .
08	PARTIAL OPENING with confirmation for safety <sup>(1)</sup> .
09	OPEN with confirmation for safety <sup>(1)</sup> .
10	CLOSE with confirmation for safety <sup>(1)</sup> .

<sup>(1)</sup> To prevent barrier manoeuvres caused by accidentally pressing a remote control button, confirmation is required to enable the command. Example: parameters 76 01 e 77 0 1 set:

- Pressing the CHA button on the remote control selects the step mode function, which must be confirmed within 2 seconds by pressing CHB on the remote control. Press CHB to activate partial opening.

<b>78 02</b>	<b>Flashing light / upper cover lights frequency configuration</b>
--------------	--------------------------------------------------------------------

00	The frequency is set electronically from the flashing light unit.
01	Slow flash. The light flashes at a lower frequency when the boom is near the mechanical stops.
02	Light flashes slowly when barrier opens, rapidly when barrier closes. The light flashes at a lower frequency when the boom is near the mechanical stops.
<b>79 00</b>	<b>Operating mode of signal lights on boom</b> <b>N.B.:</b> to reduce power consumption, the controller automatically sets this par. to 04 during battery powered operation.
00	Disabled. Lights always off.
01	Lights always on.
02	Lights on with boom stationary, flashing when boom is moving.
03	Short flash with boom stationary, flashing normally when boom is moving.
04	Short flash with boom closed, flashing normally when boom is moving, off when boom is open.
<b>80 00</b>	<b>Clock contact configuration</b> When the clock function is active, the barrier opens and remains open. At the end of the programmed time set with the external device (clock), the barrier closes.
00	When the clock function is active, the barrier opens and remains open. Any command signal received is ignored.
01	When the clock function is active, the barrier opens and remains open. Any command signal received is accepted. When the barrier returns to the completely open position, the clock function is reactivated.
<b>81 00</b>	<b>Enable safeguarded barrier closure</b> Enabling this parameter ensures that the barrier is not left open due to incorrect and/or accidental commands. This function is <b>NOT</b> enabled if: <ul style="list-style-type: none"> <li>• the barrier receives a STOP command;</li> <li>• the sensing edge is activated;</li> <li>• the number of closure attempts set by parameter R2 has been reached.</li> </ul>
00	Disabled. Parameter B2 is not visible.
01	Enabled. If the barrier is closed as a result of a step mode command, after a period of time set with parameter B2, the control unit signals a 5 second warning with the flashing light (regardless of the parameter R5), and then the barrier closes.
<b>82 03</b>	<b>Safeguarded closure activation time setting</b> <b>N.B.:</b> this parameter is not visible if the value of parameter B1 = 00.
02-90	Wait time settable from 2 to 90 s.
92-99	Wait time settable from 2 to 9 min.
<b>83 00</b>	<b>Parking access mode selection</b> <b>N.B.:</b> If enabled with values 01, 02 or 03, photocell activation during a closing manoeuvre will always trigger a reopening manoeuvre unless parameter B4 01 is set. Parameters R2, R7, S0, S1, S2 and S6 are not visible. With B3 = 01, 02, 03 the barrier re-closes after a pause time set at parameter Z1 (if Z1 is set to a value different from 00).
	<b>i</b> For more information, see chapter 14 "Examples of applications in parking access mode".
00	Disabled. Parameter B4 is not visible.
01	<b>Bi-directional mode with immediate closure.</b> When entering and leaving the parking area, the barrier is opened with an <b>AP</b> open command. Once the vehicle has crossed the barrier and released contact <b>FT</b> (NC) (e.g. from magnetic loop), the barrier closes immediately. When parameter Z1=00, the barrier open and remains open until the vehicle has completed the passage. If the vehicle moves back, the barrier remains open. <b>NOTE:</b> it is possible to add further 5 s delay before closing, setting R5 99.
02	<b>Directional mode 1.</b> When entering the parking area, the barrier is opened with an <b>AP</b> open command. Once the vehicle has crossed the barrier and released contacts <b>FT</b> (NC) and <b>PED</b> (NO), the barrier closes. When leaving the parking area, the barrier is opened by a <b>PED</b> command received from the magnetic loop. Once the vehicle has crossed the barrier and released contact <b>FT</b> (NC), the barrier closes. When parameter Z1=00, the barrier open and remains open until the vehicle has completed the passage. If the vehicle moves back, the barrier remains open. <b>NOTE:</b> it is possible to add further 5 s delay before closing, setting R5 99.

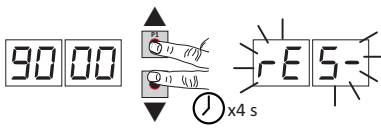
	<p><b>Directional mode 2.</b> When entering, the barrier is opened with an <b>AP</b> open command, and closes after the automatic closing time set with parameter <math>\tau 1</math>.</p> <p><b>NOTE:</b> in order to have the automatic closing set parameter <math>\tau 1</math> different to <math>\tau 0</math>.</p> <p>When leaving the parking area, the barrier is opened by a <b>PED</b> command received from the magnetic loop. Once the vehicle has crossed the barrier and released contact <b>FT</b> (NC), the barrier closes.</p> <p><b>NOTE:</b> it is possible to add further 5 s delay before closing, setting <b>A5 99</b>.</p>
<b>84 00</b>	<p><b>Enable close command after activation of photocell (FT)</b> <b>N.B.:</b> this parameter is not visible if <b>B3 00</b>.</p>
<b>00</b>	Disabled.
<b>01</b>	Enabled. The barrier stops if the photocell is activated during closing manoeuvre. The barrier resumes closing when the photocell is cleared.
<b>85 00</b>	<p><b>Selection of the battery operation management</b> Setting a value different than <b>00</b> a battery voltage level check is activated. The desired operation type can be selected via parameter <b>B6</b> and an error alert can be activated through the SC output via parameter <b>20</b>.</p>
<b>00</b>	The control unit always accepts commands until the battery is completely exhausted.
<b>01</b>	The command becomes active when the battery voltage drops to the minimum threshold (22Vdc for battery 2x12Vdc)
<b>02</b>	The command becomes active when the battery voltage drops to the medium threshold (23Vdc for battery 2x12Vdc)
<b>03</b>	The command becomes active when the battery voltage drops to the maximum threshold (24Vdc for battery 2x12Vdc)
<b>86 00</b>	<p><b>Selecting the battery operation limitations</b> <b>N.B.:</b> the parameter is visible only if par. <b>B5</b> is different than <b>00</b></p>
<b>00</b>	There is no limitation for the commands when the battery voltage drops under the selected threshold. An error alert may be activated via the SC output (if parameters <b>B5</b> and <b>20</b> are adequately set).
<b>01</b>	When the battery voltage drops under the threshold selected with par. <b>B5</b> , the control unit accepts only opening commands and does not perform closing.
<b>02</b>	When the battery voltage drops under the threshold selected with par. <b>B5</b> , after a 5 s pre-flashing, the control unit automatically opens the barrier's boom and accepts only a closing command.
<b>03</b>	It accepts only closing commands even if the ORO input is active and if the parameter is <b>B0 01</b> .
<b>04</b>	When the battery voltage drops to the threshold selected with par. <b>B5</b> the control unit, after a prelamp of 5s, automatically closes the gate and accepts only one opening command.
<b>87 00</b>	<p><b>Selection of the battery type and consumption reduction</b> <b>NOTE:</b> An INCORRECT setting of this parameter, when there is no mains voltage, blocks the functions and the display shows the message <b>bEtL 0</b> (if set to <b>02</b> or <b>03</b> and the battery is 2x12Vdc) or an error alert <b>b mod</b>.</p>
<b>00</b>	Battery 24Vdc (2x12V) with B71/BCHP. Acceleration/deceleration/speed reduction enabled, to increase the battery life.
<b>01</b>	Battery 24Vdc (2x12V) with B71/BCHP. No performance reduction, maximum battery consumption.
<b>02</b>	Battery 36Vdc (3x12V) with external charger. Acceleration/deceleration/speed reduction enabled, to increase the battery life. - DO NOT SELECT. FUTURE USE -
<b>03</b>	Battery 36Vdc (3x12V) with external charger. No performance reduction, maximum battery consumption. - DO NOT SELECT. FUTURE USE -
<b>90 00</b>	<p><b>Restoring factory default values</b> <b>NOTE</b> This procedure is only possible if NO data protection password is set. <b>N.B.:</b> This parameter is not visible for the SLAVE barrier.</p>
	<p><b>Warning!</b> Restoring default settings cancels all settings made previously except for parameter <b>A1</b> : after restore, check that all parameters are suitable for the installation. The default factory settings may also be restored using the <b>▲</b> (up arrow) and <b>▼</b> (down arrow) buttons as follows:</p> <ul style="list-style-type: none"> <li>• Turn off the power.</li> <li>• Press and hold the <b>▲</b> (up arrow) and <b>▼</b> (down arrow) button until the unit switches on.</li> <li>• The display flashes after 4 s <b>rE5-</b>.</li> <li>• The default factory settings have now been restored.</li> </ul>

<b>Identification number</b> The identification number consists of the values of the parameters from $n0$ to $n6$ . <b>N.B.:</b> The values shown in the table are indicative only.		
$n001$	<b>HW version</b>	
$n123$	<b>Year of manufacture</b>	
$n245$	<b>Week of manufacture</b>	
$n367$	Example: 01 23 45 67 89 01 23 45	
$n489$		<b>Serial number</b>
$n501$		
$n623$	<b>FW version</b>	
$n745$	<b>RS485 serial communication version</b>	

<b>View manoeuvre counter</b> The number consists of the values of the parameters from $o0$ to $o1$ multiplied by 100. <b>N.B.:</b> The values shown in the table are indicative only.	
$o001$	<b>Manoeuvres performed</b> Example: 01 23 45 x100 = 1,234,500 manoeuvres
$o023$	
$o145$	

<b>View manoeuvre hour counter</b> The number consists of the values of the parameters from $h0$ to $h1$ . <b>N.B.:</b> The values shown in the table are indicative only.	
$h001$	<b>Manoeuvre hours</b> Example: 01 23 = 123 hours
$h123$	

<b>View control unit days on counter</b> The number consists of the values of the parameters from $d0$ to $d1$ . <b>N.B.:</b> The values shown in the table are indicative only.	
$d001$	<b>Days with unit switched on</b> Example: 01 23 = 123 days
$d123$	

<b>Password</b> Setting a password prevents unauthorised persons from accessing the settings. With password protection active ( $CP=01$ ), parameters may be viewed but the values CANNOT be modified. Only a single password is used to control access to the barrier automation system. <b>WARNING:</b> Contact the Technical Support Service if you lose your password. <b>N.B.:</b> This parameter is not visible for the SLAVE barrier.	
$P100$ $P200$ $P300$ $P400$	<b>Password activation procedure:</b> <ul style="list-style-type: none"> <li>• Enter the desired values for parameters <math>P1</math>, <math>P2</math>, <math>P3</math> and <math>P4</math>.</li> <li>• Use the UP▲ and/or DOWN▼ buttons to view parameter <math>CP</math>.</li> <li>• Press and hold the + and - buttons for 4 seconds.</li> <li>• The display flashes to confirm that the password has been saved.</li> <li>• Switch the control unit off and on again. Check that password protection is activated (<math>CP=01</math>).</li> </ul> <b>Temporary unlock procedure:</b> <ul style="list-style-type: none"> <li>• Enter the password.</li> <li>• Check that <math>CP=00</math>.</li> </ul> <b>Password cancellation procedure:</b> <ul style="list-style-type: none"> <li>• Enter the password (<math>CP=00</math>).</li> <li>• Save the values <math>P1</math>, <math>P2</math>, <math>P3</math>, <math>P4 = 00</math></li> <li>• Use the UP▲ and/or DOWN▼ buttons to view parameter <math>CP</math>.</li> <li>• Press and hold the + and - buttons for 4 seconds.</li> <li>• The display flashes to confirm that the password has been cancelled (the values <math>P100</math>, <math>P200</math>, <math>P300</math> and <math>P400</math> and indicate that no password is set).</li> <li>• Switch the control unit off and on again (<math>CP=00</math>).</li> </ul>

$CP00$	<b>Password change protection</b>
00	Protection deactivated.
01	Protection activated.

# 14 Examples of applications in parking access mode

The **CTRL** controller manages the system in parking access mode.  
 The function is enabled through the parameter **B3** and ONLY the **AP** and/or **PED** command inputs at the terminal board must be used.  
**N.B.:** the input **FT** cannot be disabled in the following operating situations. If the contact (NC) is opened during a closing manoeuvre, the barrier reopens and remains open until the contact is closed again.

## • Bi-directional mode with immediate closure (B3 01)

When entering and leaving the parking area, the barrier is opened with an **AP** open command (terminal block or radio command).  
 Once the vehicle has crossed the barrier and released contact **FT** (NC) (e.g. from magnetic loop), the barrier closes immediately.  
 When parameter **2 I=00**, the barrier open and remains open until the vehicle has completed the passage. If the vehicle moves back, the barrier remains open.

If parameter **2 I** has a value different from **00**, the barrier re-closes after an automatic re-closure set time.

**NOTE:** it is possible to add further 5 s delay before closing, setting **A5 99**.

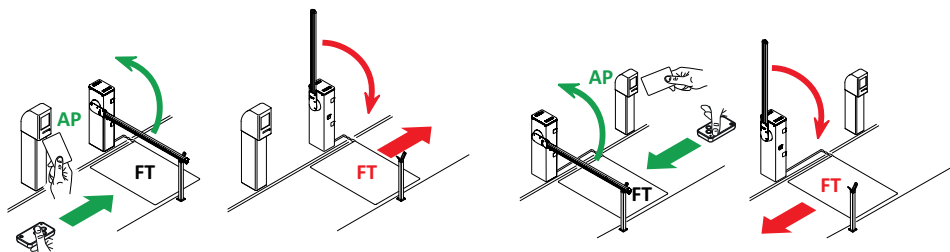

## • Directional mode 1 (B3 02)

When entering the parking area, the barrier is opened with an **AP** open command (terminal block).

Once the vehicle has crossed the barrier and released contacts **FT** (NC) and **PED** (NO), the barrier closes.

When leaving the parking area, the barrier is opened by a **PED** command received from the magnetic loop.

Once the vehicle has crossed the barrier and released contact **FT** (NC), the barrier closes.

When parameter **2 I=00**, the barrier open and remains open until the vehicle has completed the passage. If the vehicle moves back, the barrier remains open.

If parameter **2 I** has a value different from **00**, the barrier re-closes after an automatic re-closure set time.

**NOTE:** it is possible to add further 5 s delay before closing, setting **A5 99**.

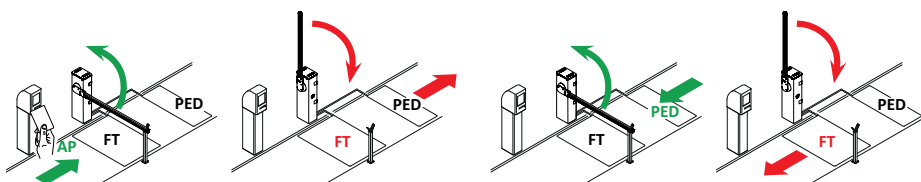

## • Directional mode 2 (B3 03)

When entering, the barrier is opened with an **AP** open command (terminal block), and closes after the automatic closing time set with parameter **2 I**.

**NOTE:** in order to have the automatic closing set parameter **2 I** different to **00**.

When leaving the parking area, the barrier is opened by a **PED** (NO) command received from the magnetic loop.

Once the vehicle has crossed the barrier and released contact **FT** (NC), the barrier closes.

**NOTE:** it is possible to add further 5 s delay before closing, setting **A5 99**.

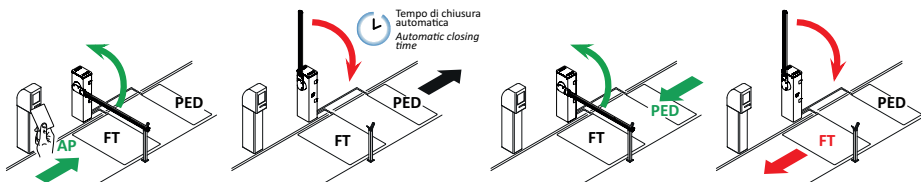

# 15 Safety input and command status (TEST mode)

With no currently active intentional commands, press the TEST button and check the following:

DISPLAY	POSSIBLE CAUSE	ACTION BY SOFTWARE	PHYSICAL CORRECTIVE ACTION
BB rS(rS)	MASTER barrier not moving. STOP contact of MASTER barrier open (message visible for SLAVE barrier).	-	Check STOP button/contact on MASTER controller. Install a STOP button (NC) or jumper the ST contact with the COM contact of the MASTER controller.
BB br	Detachable boom support system enabled or not connected or incorrect connection.	Check the settings of parameter 19.	Check the correct system connection to the control unit.
BB 21	Safety STOP contact open.	-	Check the STOP button/contact. Install a STOP button (NC) or jumper the ST contact with the COM contact.
	Release device open.	-	<b>AGILIK-KB-BI/004HP-BI/006-BI/008</b> Lock by turning the key two complete turns clockwise. Check that the microswitch contact is connected correctly. <b>BIONIK4</b> Close the release lock cover and turn the key. Check that the microswitch contact is connected correctly.
	Barrier inspection hatch open.	-	Close the barrier inspection hatch. Check connection to microswitch.
BB 23	Sensing edge <b>COS</b> not connected or incorrectly connected.	Set the parameter 73 00 if not used or to disable.	If not used jumper contact <b>COS</b> with contact COM.
BB 24	Photocell <b>FT</b> not connected or incorrectly connected.	Set parameters 50 00 and 51 00 if not used or to disable.	If not used jumper contact <b>FT</b> with contact COM. Check connection referring to relative connection diagram (figures 4-5).
PP 00	If occurs with no voluntary command, the contact may be faulty or one of the buttons may be incorrectly connected.	-	Check PP - COM contacts and connections to button.
CH 00		-	Check CH - COM contacts and connections to buttons.
AP 00		-	Check AP - COM contacts and connections to button.
PE 00		-	Check PED - COM contacts and connections to button.
OR 00		-	Check contacts ORO - COM. Do not jumper this contact if not used.

**N.B:** press TEST to exit TEST mode.

We recommend troubleshooting safety device and input status errors with "corrective action by software" only.



# 16 Alarms and faults

EN

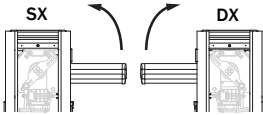
PROBLEM	ALARM SIGNAL	POSSIBLE CAUSE	CORRECTIVE ACTION
The barrier does not open or close.	<b>POWER</b> LED off	No power.	Check power cable.
	<b>POWER</b> LED off	Fuses blown.	Replace fuse. Always disconnect from mains power before removing and refitting fuses.
	<i>FUSE</i>	Fuse F1 blown or damaged. This message is not visible if controller is in battery power mode.	Replace fuse. Always disconnect from mains power before removing and refitting fuses.
	<i>DF 5t</i>	Input mains power voltage fault. Controller initialisation failed.	Disconnect from mains power, wait 10 seconds then reconnect to the mains and switch on. We recommend replacing the control unit if the problem persists.
	<i>P- 0t</i>	Overcurrent detected in inverter.	Press the <b>TEST</b> button twice or perform 3 command requests in succession.
	<i>SEC 0</i>	Incorrect connection between SEC1 and SEC2 of the transformer.	Swap the connection between SEC1 and SEC2.
	<i>dRA tA</i>	Travel data acquisition error.	Check that the spring is balanced correctly with the barrier unlocked. Press TEST and check if any safety devices are in alarm state. Repeat acquisition procedure.
		Calibration procedure failed ( <i>PHAS</i> ).	Allow the indicated calibration times to elapse during self-acquisition. Before re-closing the release lock cover, ensure that on the display will flash <i>PHAS</i> . Repeat acquisition procedure.
		Automation system position selection modification message with parameter 7 I.	 <p>Motors for barriers are factory configured for right hand opening barriers 7 I D I (position of barrier relative to passage seen from inspection hatch side). If the position is changed and message <i>dRA tA</i> is displayed:</p> <ul style="list-style-type: none"> <li>• Move the boom 45° degree.</li> <li>• Adjust the spring position correctly for the required opening direction.</li> <li>• Press and hold <b>PROG</b> until <i>dRA tA</i> disappears and <i>APP-</i> appears on the display.</li> </ul> <p>Repeat acquisition procedure.</p>
		<i>Mo t</i>	Motor not connected.
	<i>brEA</i>	BreakAway system alarm.	<ul style="list-style-type: none"> <li>• Check the setting of par. 19.</li> <li>• Check the correct <b>ACS/BA/60</b> system connection to the control unit.</li> <li>• Re-engage the boom.</li> <li>• Consider replacing the boom if it is damaged.</li> </ul>
	Example: <i>2 I EE</i> <i>33 EE</i>	Configuration parameter error.	Set configuration value correctly and save.

PROBLEM	ALARM SIGNAL	POSSIBLE CAUSE	CORRECTIVE ACTION
<b>The barrier does not open or close.</b>	<b>StoP flashing</b>	Release device open.	<b>AGILIK-KB-BI/004HP-BI/006-BI/008</b> : Lock by turning the key two complete turns clockwise. <b>BIONIKA4</b> : Close the release lock cover and turn the key.
		Open barrier inspection hatch (if the emergency stop micro-switch is installed).	Close the inspection hatch correctly and check the micro-switch connection.
		LOCKS connectors incorrectly connected.	Check the connector connections. Jumper one of the two LOCKS connectors.
		STOP button/contact active for more than 5 s.	Check connections to STOP button.
		For MASTER-SLAVE systems, the <b>ACS/BA/60</b> BreakAway system is active on the MASTER barrier.	Check the BreakAway system and if the alarm event is solved, re-engage the <b>ACS/BA/60</b> system.
	<i>EnE 1</i>	Encoder 1 not connected.	Check connection to encoder. Replacing the encoder is recommended if the problem persists.
	<i>EnE2</i>	Encoder 2 not connected.	Check connection to encoder. Replacing the encoder is recommended if the problem persists.
	<i>EnE3</i>	Severe encoder 1 malfunction.	Press TEST button. If the error code is displayed again, switch off the controller unit, wait 5 seconds and switch on again. Replace the encoder if the problem persists.
	<i>EnE4</i>	Severe encoder 2 malfunction.	Press TEST button. If the error code is displayed again, switch off the controller unit, wait 5 seconds and switch on again. Replace the encoder if the problem persists.
	<i>EnE5 (EnE5)</i>	Encoder 1 malfunction.	Press <b>TEST</b> button or perform 3 command requests in succession. Replace the encoder if the problem persists.
		Operation in battery mode.	Batteries almost flat.
	<i>EnE6</i>	Encoder 2 malfunction.	Press <b>TEST</b> button or perform 3 command requests in succession. Replace the encoder if the problem persists.
		Operation in battery mode.	Batteries almost flat.
	<i>EnE7</i>	Encoder 1 calculation error.	Repeat acquisition procedure.
	<i>EnE8</i>	Encoder 2 calculation error.	Repeat acquisition procedure.
	<i>tEnP</i>	Inverter overheat protection triggered.	Function is restored automatically within 2 minutes.
	<i>btLO (btLO)</i>	Flat batteries.	Wait for mains power to be restored.
	<i>CO1</i>	No RS485 serial communication between MASTER barrier and SLAVE barrier.	Check connection to terminals COM-LNA-LNB.
			Check settings of parameter <i>AO</i> . Check that battery kit is installed on both MASTER and SLAVE barriers.
	<i>CO2</i>	Serial communication interference: two MASTER controllers detected.	Check settings of parameter <i>AO</i> .
<i>CO3</i>	Parameter configuration transfer error between MASTER and SLAVE.	Check connection to terminals COM-LNA-LNB.	
<i>CO4</i>	Controller unit models not compatible.	Check installation and replace one or both controller units.	
<i>CO5 (COM5)</i>	Incompatibility between firmware versions of controller units.	Check parameter <i>n7</i> . Both controllers must have the same firmware version. Contact the technical assistance.	

PROBLEM	ALARM SIGNAL	POSSIBLE CAUSE	CORRECTIVE ACTION
<b>Acquisition procedure does not complete correctly.</b>	<i>n0 PH</i>	Motor calibration failed.	Repeat acquisition procedure. If the problem persists, check the cable connecting encoder 1 to the motor.
	<i>RP PE</i>	TEST button pressed accidentally.	Check that the motor turns without impediment. Contact technical support in case of any problems.
		Safety devices in alarm state.	Repeat acquisition procedure.
<b>Barrier does not perform desired manoeuvre.</b>	-	Excessive voltage drop.	Check connections of safety devices. Repeat acquisition procedure; check mains voltage.
<b>The barrier opens/closes for a short distance and then stops.</b>		Incorrect setting of parameter 7 I.	Select the correct installation position with parameter 7 I. Repeat acquisition procedure.
		Incorrect setting of parameter A I.	Check type of boom and set parameter A I correctly. Repeat acquisition procedure.
		Incorrect values for installation type.	Set values of parameters 33, 34, 40 and 4 I correctly for installation type.
	<i>b7od</i>	Incorrect spring setting.	See the barrier instructions for spring balancing.
		Battery operation management (par. 85 different than 00) not detected.	Change the value of the parameter 87.
<b>The remote control has limited range and does not work with the automation moving.</b>	-	Radio signals are impeded by metal structures and reinforced concrete walls.	Install the antenna.
	-	Flat batteries.	Replace the radio control batteries.
<b>The flashing light is not working.</b>	-	Bulb / LED blown or flashing light wires disconnected.	Check LED circuit and/or connector wires.
<b>Barrier open indicator lamp does not work.</b>	-	Bulb blown or wires disconnected.	Check the bulb and/or wires.

**N.B.:** Press the TEST button to temporarily cancel the alarm.

The next time a command is received, the alarm reappears on the display if the problem has not been resolved.

# 17 Procedural verifications - INFO Mode

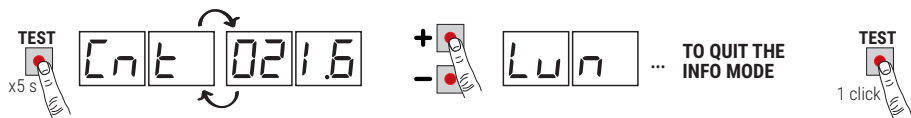

INFO mode may be used to view certain parameters measured by the **CTRL** controller. Press and hold the TEST button for 5 seconds from the “View command signals and safety devices” mode with the motor stationary. The controller displays the following parameters in sequence:

Parameter	Function
<i>P4.10</i>	View for 3 s the firmware version of the control unit.
<i>Ctrl</i>	View barrier position (ENCODER data) at time of test, in motor revolutions. (example: <i>021.6</i> = barrier installed on the right; <i>-21.6</i> = barrier installed on the left).
<i>LUn</i>	View total length of programmed travel, in motor revolutions (e.g.: <i>037.8</i> = 37.8 motor revolutions).
<i>rPM</i>	View motor speed, in revolutions per minute (rPM).
<i>ANP</i>	View current absorption of motor, in Amperes (e.g.: <i>016.5</i> = 16.5 A). If the motor is stationary, the current absorption value is 0.
<i>bUS</i>	System OK indicator. To check for overloading (e.g.: too many utilities connected to 24 V output) or if the mains voltage is too low, compare the parameters read with values indicated as follows with the motor stationary: mains voltage = 230 V AC (nominal), bUS= <i>37.6</i> mains voltage = 207 V AC (-10%), bUS= <i>33.6</i> mains voltage = 253 V AC (+10%), bUS= <i>41.6</i>
<i>tin</i>	Indicates time taken by motor to detect an obstacle, as set with parameter <i>3i</i> , in seconds. E.g. <i>1.000</i> = 1 s / <i>0.120</i> = 0.12 s (120 ms). Ensure that the manoeuvre time is more than 0.3 s.
<i>MSrA</i>	Displays a number which indicates the status of the control unit (INTERNAL USE - ROGER TECHNICAL ASSISTANCE)
<i>rSrA</i>	Displays a number which indicates the status of the SLAVE control unit (INTERNAL USE - ROGER TECHNICAL ASSISTANCE) and visible only on the MASTER control unit; on the SLAVE control unit, ---- is always displayed.
<i>ErrL</i>	Number of RS485 communication errors (it gets reset by pressing “arrow down” ▼): this could highlight problems at board circuit level.
<i>ErrC</i>	Number of communication protocol errors (it gets reset by pressing “arrow down” ▼). It can highlight: • problems at connection cable level <b>LNA/LNB/COM</b> (reduced section, excessive length, closeness to cables with switching loads) • difficulties in communicating with the SLAVE control unit.
<i>OC</i>	Indicates the state of the automation system (open/closed). <i>OC OP</i> automation system opening (motor active). <i>OC CL</i> automation system closing (motor active). <i>OC -O</i> automation system completely open (motor not actives). <i>OC -C</i> automation system completely closed (motor not actives).
<i>Od</i>	Indicates activation of the obstacle detection system. <i>Od -1</i> obstacle detection activated.
<i>UF</i>	<i>UF U</i> mains voltage too low or overload. <i>UF H</i> motors overcurrent. <i>UF S</i> malfunction detected, reduce acceleration and speed settings, and check spring setting.

- Use the + / - buttons to scroll through the parameters. When the last parameter in the sequence is reached, press the = button to return through the previous parameters.
- In INFO mode, the automation system may be activated to test operation in real time.
- Press and hold the TEST button for a few seconds to exit INFO mode.

## 18 Mechanical release

---

In the event of a fault or mains power loss, the barrier may be released and opened manually.



For further information, refer to the locking/release operation in the manual of the BIONIK4, BIONIK4HP, BIONIK6, BIONIK8 automation system.

If the barrier is unlocked while the controller is powered, the message **5EOP** flashes on the display until the barrier is locked again.

The flashing light and the signal lights (if installed) illuminate if the boom is moved manually.

If a "ventouse" electric lock is installed, unlocking the barrier cuts off the power supply, making it possible to move the boom manually.

The barrier resumes normal operation once the release system is locked again.

## 19 Initial testing

---

The testing must be performed by qualified technical personnel.

The installer is required to measure impact forces and select on the control unit the appropriate speed and torque values to ensure that the motorised door or gate remains within the limits defined by the standards EN 12453 and EN 12445.

Make sure that the provisions in Chapter 1 "GENERIC WARNINGS are observed.

- Turn on the power supply.
- Perform travel acquisition.
- Set acceleration, speed and deceleration values. Check that the values are correct for the installation type. The boom must approach the mechanical stop at low speed, and then press gently against the stop to hold the boom in the closed position. Setting a value between  $\square 1$  and  $\square 3$  for parameter  $42$  ensures that the boom approaches and arrests against the stops slowly without vibration. For booms up to 4 m in length, values between  $\square 5$  and  $\square 8$  are recommended for parameters  $43$  and  $44$ . For longer booms, set a higher value.  
**NOTE:** for BIONIK8 barriers, pay special attention when setting parameter  $44$ . Avoid excessive oscillation upon reaching the end stop when closing.
- Check that all connected controls are working correctly.
- Check that the release device functions correctly. The message **5EOP** must flash on the display.
- Check if the impact forces are compliant with the EN 12453 and EN 12445 standards.
- Check that the safety devices are activated correctly.
- If installed, check the correct operation of the BreakAway **ACS/BA/60** detachable boom coupling system.
- If the battery kit is installed, disconnect from mains and check that the batteries are working.
- Disconnect from mains power and disconnect the batteries (if used), then reconnect. With the barrier stopped in an intermediate position, check that the manoeuvre is performed correctly.
- Check that the mechanical stops are set correctly. Repeat the travel acquisition procedure after each adjustment.
- In the case of installations with two opposed barriers, request a manoeuvre and check that both barriers function correctly.
- If a "ventouse" electric lock is used, check that when the boom is completely closed the lock activates and the boom cannot be lifted from the fixed end rest with integrated magnet.

## 20 Start-up

---

The installer is required to draw up and preserve the technical file of the system for at least 10 years, which must contain the wiring diagram, the drawing and the photo of the system, the risk analysis and the solutions adopted, the manufacturer's declaration of conformity for all connected devices, the instructions manual of each device and / or accessory and the system's maintenance plan.

Apply a plate indicating the automation system data on the motorised door or gate, the name of the person in charge of the start-up, the serial number and the year of construction, as well as the CE mark.

Apply a plate and / or label with the indications for the operations required to manually unlock the system.

Draw up and provide the end user with the declaration of conformity, instructions and warnings for use and the maintenance plan.

Make sure that the end user has understood the correct automatic, manual or emergency operation of the system.

Inform the end user about the dangers and risks that may be present.

## 21 Maintenance

---

Perform scheduled maintenance every 6 months.

Check cleanliness and function.

If the unit contains dirt, moisture, insects or other foreign matter, disconnect from mains power and clean the board and the housing.

Repeat the initial installation test procedure after cleaning.

If any corrosion is found on the printed circuit board, evaluate if it is necessary to replace the board itself.

Make sure the batteries are in good working order (if installed).

## 22 Disposal

---



This product may only be uninstalled by qualified technical personnel, following suitable procedures for removing the product correctly and safely.

This product consists of numerous different materials.

Some of these materials may be recycled, while others must be disposed of correctly at the specific recycling or waste management facilities indicated by local legislation applicable for this category of product.

Do not dispose of this product as domestic refuse.

Observe local legislation for differentiated refuse collection, or hand the product over to the vendor when purchasing an equivalent new product.

Local legislation may envisage severe fines for the incorrect disposal of this product.

**Warning!** some parts of this product may contain substances that are harmful to the environment or dangerous and which may cause damage to the environment or health risks if disposed of incorrectly.

## 23 Additional information and contact details

---

ROGER TECHNOLOGY is the exclusive proprietor holder of all rights regarding this publication.

ROGER TECHNOLOGY reserves the right to implement any modifications without prior notification. Copying, scanning or any alterations to this document are prohibited without express prior authorised from by ROGER TECHNOLOGY.

This instruction manual and the warnings for the installer are given in printed form and included in the box containing the product.

The digital version of this documentation (in PDF format) and all future revisions are available from the reserved area of our website [www.rogertechnology.com/B2B](http://www.rogertechnology.com/B2B), in the section 'Self Service'.

### **ROGER TECHNOLOGY CUSTOMER SERVICE:**

business hours: Monday to Friday  
08:00 to 12:00 - 13:30 to 17:30

Telephone no: +39 041 5937023

E-mail: [service@rogertechnology.it](mailto:service@rogertechnology.it)

Skype: service\_rogertechnology