

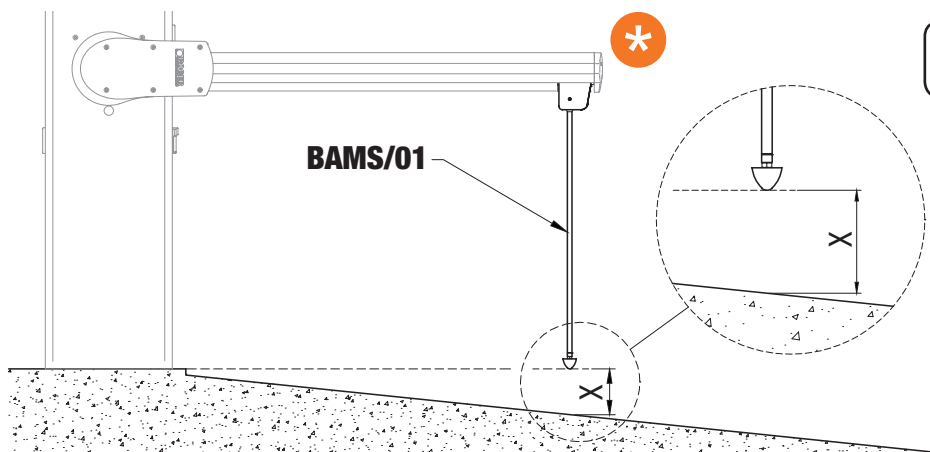

BAMS/01/EXT

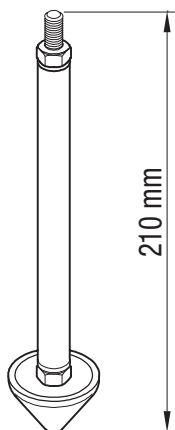

1

BAMS/01

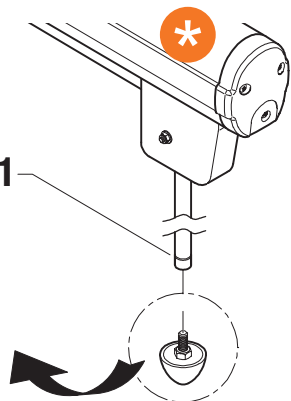

- IT** Svitare e togliere il piedino dall'appoggio mobile **BAMS/01**.
- EN** Unscrew and remove the foot from the hinged end rest **BAMS/01**.
- DE** Den Fuß vom beweglichen Ständer **BAMS/01** abschrauben.
- FR** Dévisser et retirer le pied de l'appui mobile **BAMS/01**.
- ES** Desenrosque y quite la pata de apoyo móvil **BAMS/01**.
- PT** Desenrosque e remova o pé a partir do apoio móvel **BAMS/01**.

2

3a

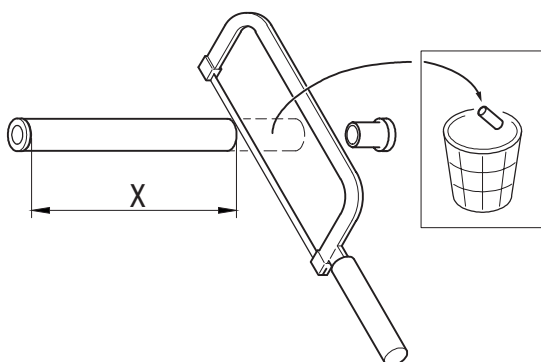

- IT** Tagliare alla misura "X", necessaria per compensare lo spazio di appoggio, la prolunga **BAMS/01/EXT**.
NOTA: smaltire adeguatamente il materiale scartato.

- EN** Cut the extension **BAMS/01/EXT** to the length "X" necessary to reach the ground.
N.B.: dispose of waste materials properly.

- DE** Die Verlängerung **BAMS/01/EXT** in Höhe des zum Ausgleich des Freiraums notwendigen Maß „X“ abschneiden. **HINWEIS:** Das abgeschnittene Material umweltgerecht entsorgen.

- FR** Couper à la mesure « X », nécessaire pour compenser l'espace d'appui, la rallonge **BAMS/01/EXT**.
REMARQUE : éliminer convenablement les chutes de matériau.

3b

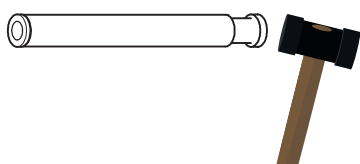

- ES** Corte a la medida "X" para compensar el espacio de apoyo, la prolongación **BAMS/01/EXT**.
NOTA: elimine oportunamente el material descartado.

3c

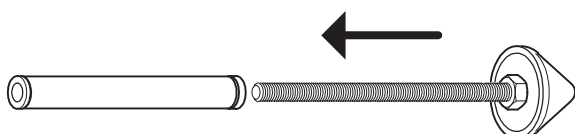

- PT** Recorte até a medida "X", necessária para compensar o espaço de apoio, a extensão **BAMS/01/EXT**.
OBSERVAÇÃO: elimine corretamente o material descartado.

4

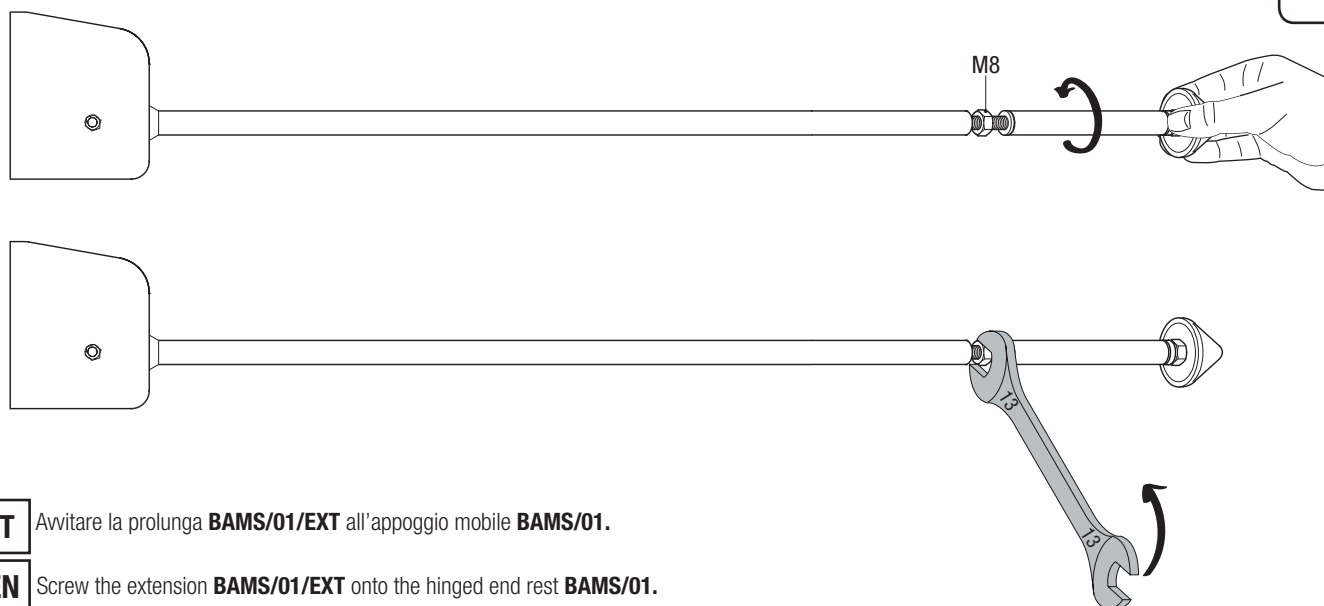

IT Avvitare la prolunga **BAMS/01/EXT** all'appoggio mobile **BAMS/01**.

EN Screw the extension **BAMS/01/EXT** onto the hinged end rest **BAMS/01**.

DE Die Verlängerung **BAMS/01/EXT** an den beweglichen Ständer **BAMS/01** anschrauben.

FR Visser la rallonge **BAMS/01/EXT** à l'appui mobile **BAMS/01**.

ES Enrosque la prolongación **BAMS/01/EXT** al apoyo móvil **BAMS/01**.

PT Aparafuse a extensão **BAMS/01/EXT** ao apoio móvel **BAMS/01**.

5

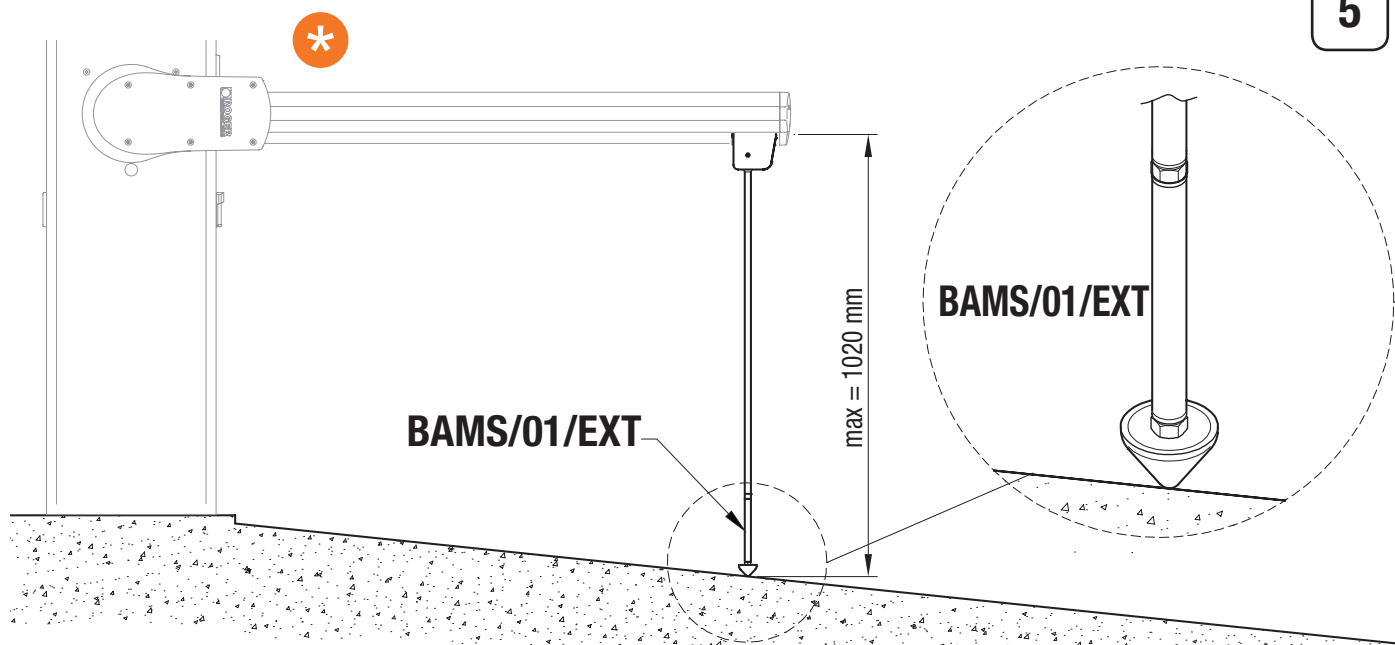

***** L'asta è puramente indicativa • *The boom is indicative only* • Das Schlagbaum ist nur indikativ. • *La barre est purement indicative* • La asta es meramente indicativa • *A hasta é puramente indicativa.*

ROGER TECHNOLOGY

Via S. Botticelli 8 • 31021 Bonisiolo di Mogliano Veneto (TV) • ITALIA
 P.IVA 01612340263 • Tel. +39 041.5937023 • Fax. +39 041.5937024
 info@rogertechnology.com • www.rogertechnology.com