

# BIONIK SERIES

THE BRUSHLESS AUTOMATED BARRIER WITH DIGITAL THINKING

 **ROGER**  
BRUSHLESS

 **ROGER**  
TECHNOLOGY  
100% Made in Italy

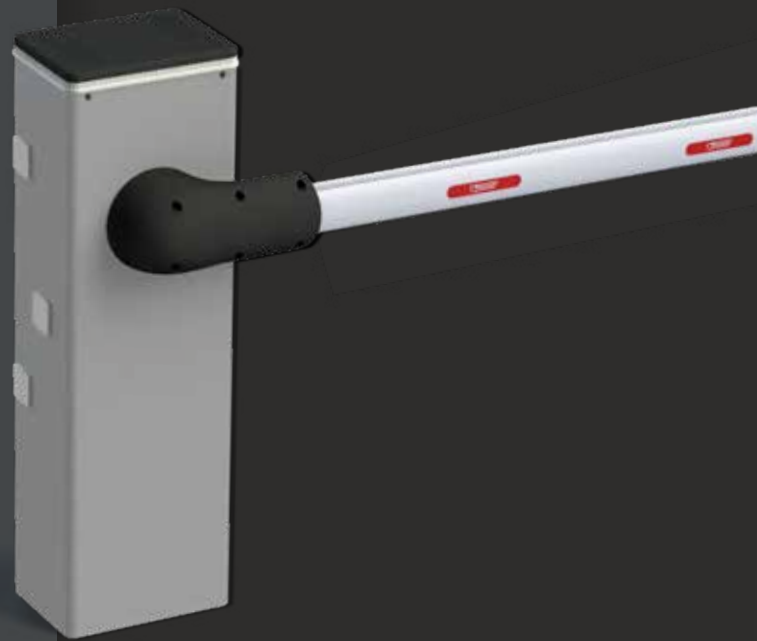

# WHAT WE DO

**INNOVATION, TOP NOTCH MECHANICS AND NEVER-ENDING TECHNOLOGICAL RESEARCH ARE THE ELEMENTS THAT MAKE ROGER TECHNOLOGY A UNIQUE AND DIFFERENT COMPANY**

Starting from our first day of work we immediately gave priority to the development and production of excellent, completely Italian mechanics, based only on top quality ferrous and non ferrous raw materials and guaranteed by impeccable production and surface treatment processes. It was just a few years later, in the 1990s, that we created the first major step in our history, by implementing a mass production line for completely robotised motors, thus becoming a reference outsourcer for major brands of the gate automation market.

## PEOPLE, IDEAS AND PRODUCT EXPERIENCE

From the very beginning **Roger Technology** has evolved and grown because it's people believe that any bright idea can lead to great change in the future. Our people are passionate and innovative in their approach to every challenge, always pushing the boundaries to develop extraordinary products.

In our language we translate the word "**experience**" as passion. It is this passion that drives us in the development of revolutionary **new products** that serve the real needs of our customers. We understand that our customers want a product designed around the way that they work.

**Primo Florian**  
Founding partner  
Engineering  
and design

**Dino Florian**  
Founding President  
Development  
and design

**Renato Florian**  
Founding partner  
Assembly  
and quality



# OUR PLUSES



## EXCELLENT RAW MATERIALS

Steel, ductile cast iron, aluminium, bronze, copper and titanium have always been the main and exclusive raw materials used in the advanced engineering processes of our company.



## PRODUCTION TECHNOLOGY

At Roger Technology all internal manufacturing is carried out on optimised production lines making use of very advanced technology. We have invested heavily in robotics and automated all product manufacturing phases. This ensures that all components and semi-finished products are highly reliable and are fully compliant with our exceptionally high quality standards.



## INTERNAL ASSEMBLY

Our highly qualified and dedicated staff oversee the fitting and assembly stages. Every piece of equipment is checked by our all Italian personnel to ensure that we deliver reliable products to our customers.



## MADE IN ITALY

All solutions, products, design and the complete production process of Roger Technology is developed in Italy with the use of materials of primary quality always found in the market through partner suppliers that share the same passion and professionalism of our company in developing products technologically reliable, efficient and simple in the way that they have been made for being installed and used.



# BRUSHLESS MOTOR

**A DIGITAL BRUSHLESS MOTOR WITH PERMANENT MAGNETIC FIELD, DIGITAL ELECTRONICS FOR THE COMPLETE MANAGEMENT OF THE AUTOMATION SYSTEM CONTROL. DESIGNED FOR SUPER INTENSIVE USE WITH THE ADDED BENEFIT OF A SUPER LOW POWER CONSUMPTION: THIS IS ROGER BRUSHLESS**

We are the creators at the heart of the product!  
All of our digital brushless motors are designed and manufactured in our own factories. Using dedicated automated machines the motors are wound with ultimate precision.

## DIGITAL BRUSHLESS MOTOR

Revolutionary and innovative digital Brushless motor with permanent magnetic field, three-phase sinusoidal power supply with native encoder that allows super-intensive use of the automation system with extremely low power consumption, not only providing 100% compliance with all the automation system management and safety rules, but setting new standards in gate safety.

## NEW GENERATION OF ELECTRONICS

The new control unit with onboard digital Brushless controller. Without traditional relays and due to the revolutionary MOSFET quadrant system and its control technology entirely based on a DSP (Digital Signal Processor) microcontroller, it represents a new generation of electronic cards created to safely handle all movement phases of the automation system.

## ENGINEERING PASSION

All the mechanical components and gears are manufactured in steel, cast iron and bronze. The automation system casings are made from titanium-reinforced die-cast aluminium. All the gears are inspected and assembled on high-quality bearings and inserted on precise seats machined to provide absolute precision between the axes.

**A TECHNOLOGY THAT OFFERS MAXIMUM PERFORMANCE  
BUT CONSUMES LESS POWER THAN OTHER MOTORS**

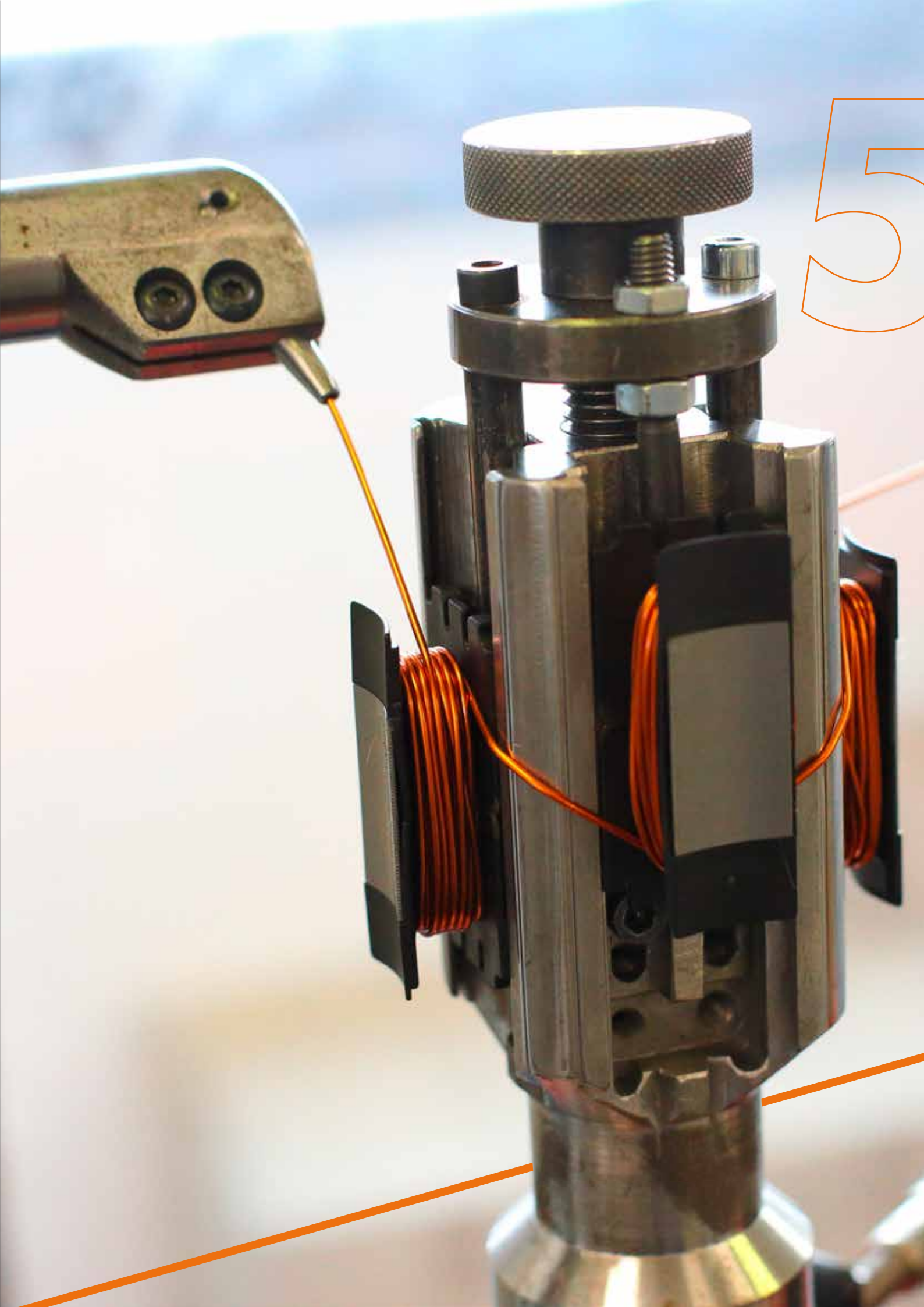

5



# COMPLETELY BRUSHLESS

THE REVOLUTIONARY DIGITAL MOTOR WITH 12 UNIQUE FEATURES



## 3-PHASE DIGITAL BRUSHLESS MOTOR

A very powerful motor with substantial torque. The motor is compact and neat due to the special concentrated coil windings, it is powered by a **three phase sinusoidal system**.



## NO PROBLEM IN THE EVENT OF POWER FAILURE

With the help of internal or external batteries and the associated battery charging card, your automation system continues to operate for a considerable time **even during prolonged power cuts**, ensuring many more operations than traditional technologies.



## SPEED, ACCELERATION AND DECELERATION WITH EXTREME ELEGANCE

The automation system with brushless digital technology creates perfect and elegant movements. With a constant **force and torque** at every point and with the option of varying the speed on deceleration and acceleration the system can be managed with maximum safety.



## EXTREMELY LOW ENERGY CONSUMPTION

A motor that can operate at low voltage in super-intensive use and which can operate in environments with extremely demanding weather conditions while maintaining **very low energy consumption and absorption levels**.



## DIGITAL AND VECTORIAL AUTOMATION CONTROLLER

The BRUSHLESS digital controller, which operates at low voltage **36V DC**, allows 100% control of the automation system in digital mode. Due to its operation entirely based on a DSP microcontroller the travel and all the movements of your automation system can therefore be programmed and customised easily, precisely and elegantly.



## MOTOR AT AMBIENT TEMPERATURE

The brushless motor was created with the main goal of being a motor for super intensive use and **with a 99% efficiency**. Regardless of how many operations the engine performs in a day, it always remains cold or at the most reaches the outside ambient temperature.



## THE DIGITAL SILENCE OF THE MOTOR

One great impact is the **silence** or the near absence of noise, generated by the BRUSHLESS motor during all its movements.



## MOTOR FOR SUPER-INTENSIVE USE

We wanted to surprise our customers with a product that was fundamentally different to any other product on the market. Fact: our motor remains **permanently cold** even after many days of super intensive use.



## IMPACT, OBSTACLE DETECTION AND REVERSAL IN TOTAL SAFETY

Thanks to digital technology we are able to **detect an obstacle** and reverse the motor instantly, by simply specifying the torque of the motor, the sensitivity, the time and the travel of the reversal. All in full compliance with safety requirements.



## ONBOARD NATIVE DIGITAL ENCODER

The BRUSHLESS motor has a highly advanced **native digital encoder** that controls management of automation systems in a safe, precise and extremely elegant manner.



## SIMPLE INSTALLATION WITH A SINGLE 3-WIRE CABLE

The BRUSHLESS motor can be installed by simply connecting it using three wires! What could be easier? This will provide full digital management of your automation system thanks to the **SENORELESS** and **SENORED** (absolute encoder) technology incorporated in the BRUSHLESS sliding gate motors.



## ADVANCED PRECISION ENGINEERING TO OBTAIN OPTIMAL MOTOR PERFORMANCE

We have created a mechanism that gives you the opportunity to get **the maximum performance out of the motor**. A product which combines the quality of the internal production processes, the mechanical processing and the use of high quality ferrous and non-ferrous materials.

# BIONIK4

## WHY BRUSHLESS?

STURDY AND ELEGANT, TO MANAGE ACCESSES TO CONDOMINIUMS,  
COMMERCIAL PREMISES, INDUSTRIAL SITES AND RESIDENTIAL AREAS

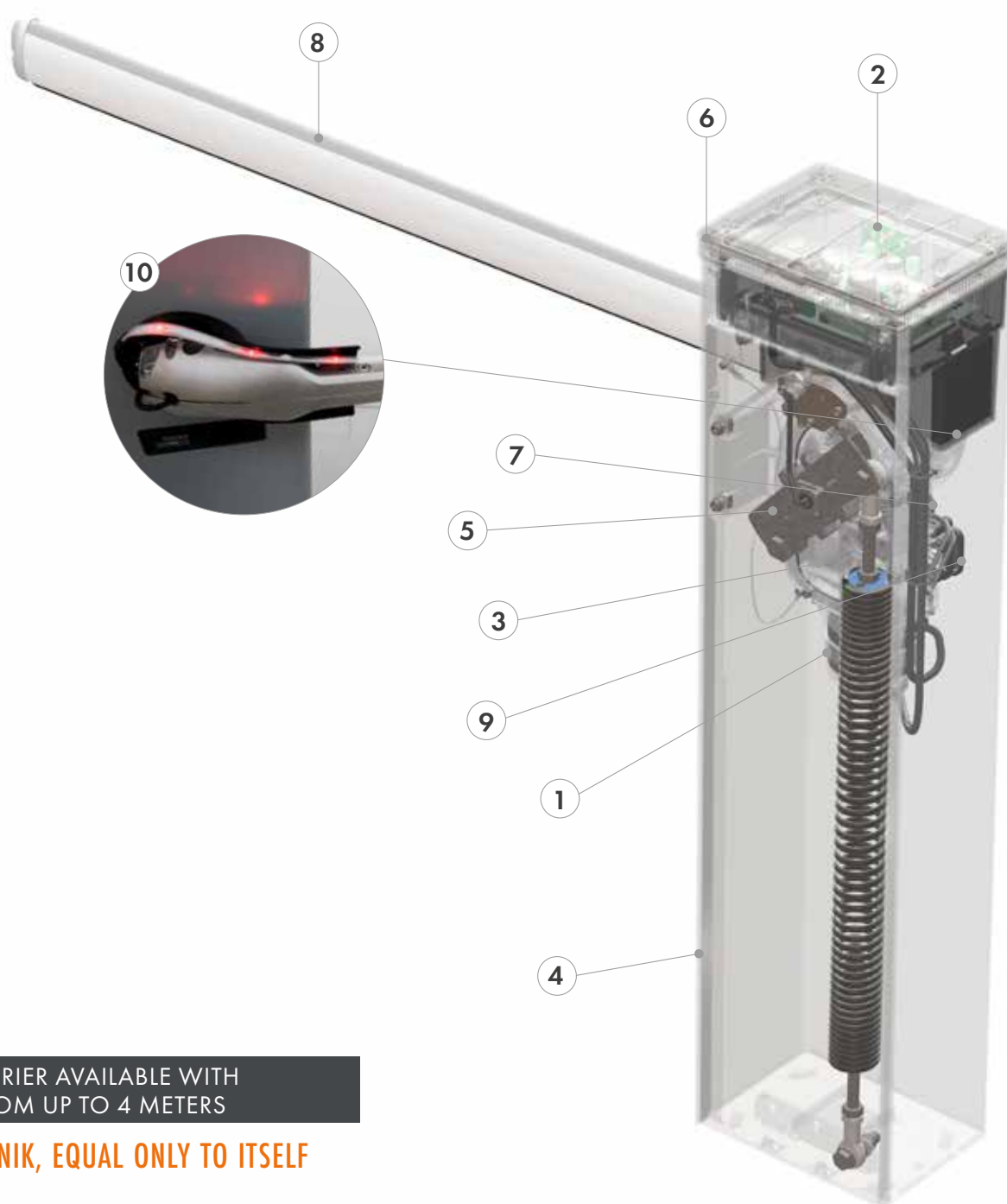

BARRIER AVAILABLE WITH  
BOOM UP TO 4 METERS

**BIONIK, EQUAL ONLY TO ITSELF**



## 1 DIGITAL 36V BRUSHLESS MOTOR

Innovative, revolutionary 36V Brushless digital motor with permanent magnetic field and a SENSORED digital technology encoder that permits unlimited use of the barrier with extremely reduced consumption and a mechanical absolute positioning system.

## 2 ADVANCED DIGITAL CONTROLLER

Easy to access, thanks to its position in the upper part of the barrier, well protected in the basket containing all the electronics, transformer compartment and support batteries. The digital controller ensures total, accurate management.

## 3 GEAR MOTOR WITH PERFECT GEARS

The gear motor is a mechanical jewel made entirely of aluminium, steel and bronze. All the gears are helicoidal with a 15° tilt, assembled on top quality bearings and inserted in perfectly machined seats to guarantee the absolute precision of the gear axes.

## 4 SMALL BUT HIGHLY RESISTANT STRUCTURE

The materials employed - steel and bronze - are top quality to ensure optimum robustness for the automation, making it highly stable during use. A vital role is also played by the surface treatment and the types of varnish, designed to make the barrier structure particularly resistant to a wide range of atmospheric agents.

## 5 LINKAGE LEVER AND SPRINGS

Different types of spring are available, according to the length of the boom and certified for millions of manoeuvres. Mechanical linkage lever with adjustable mechanical stops.

## 6 LED LIGHTING

Elegant LED lighting circuit all over the aluminium head of the barrier column. Can be configured via the control unit.

## 7 ABSOLUTE MECHANICAL POSITIONER

Powerful, innovative and accurate encoder with absolute positioning, mounted on the slow reducer shaft. Allows movements to be managed in tenths of a degree, and ensures perfect automation restart without relearning after the blackout or manual release phases.

## 8 ROBUST, ELLIPTIC BOOM

Aluminium boom with an elliptical section providing greater wind resistance, and central ribbing for even greater stability and robustness. Integrated signalisation LED on the upper side. Can be configured via the control unit.

## 9 ROBUST, INNOVATIVE RELEASE

Mechanical manual release with standard cylinder lock, able to unlock the barrier in any situation thanks to its excellent mechanics based on a twin-acting elliptical lever.

## 10 BIONIC BOOM SUPPORT ARM

Bionic support and protection arm in die-cast aluminium, directly connected to the reducer via a special system for pre-reducing the mechanical stress of the boom movement.



# BIONIK4HP BIONIK6

## WHY BRUSHLESS?

STURDY AND ELEGANT, TO MANAGE ACCESSES TO COMMERCIAL AND INDUSTRIAL PREMISES AS WELL AS HEAVY TRAFFIC PARKING LOTS



BARRIER AVAILABLE WITH  
BOOM FROM 3 TO 6 METERS

**BIONIK, EQUAL ONLY TO ITSELF**

## 1 DIGITAL 36V BRUSHLESS MOTOR

Innovative, revolutionary 36V Brushless digital motor with permanent magnetic field and a SENSORED digital technology encoder that permits unlimited use of the barrier with extremely reduced consumption and a mechanical absolute positioning system.

## 2 ADVANCED DIGITAL CONTROLLER

Easy to access, thanks to its position in the upper part of the barrier, well protected in the basket containing all the electronics, transformer compartment and support batteries. The digital controller ensures total, accurate management.

## 3 GEAR MOTOR WITH PERFECT GEARS

A veritable mechanical "gem", the gear motor is made entirely of aluminium, steel and bronze. All gears are helicoidal with a 15° tilt, assembled on top quality bearings and inserted in perfectly machined seats to guarantee absolute precision of the gear axes. The take-off of the connecting shaft to the boom is of 45 mm.

## 4 HIGHLY RESISTANT STRUCTURE

The materials employed - steel and bronze - are top quality to ensure optimum robustness for the automation, making it highly stable during use. A vital role is also played by the surface treatment and the types of varnish, designed to make the barrier structure particularly resistant to a wide range of atmospheric agents.

## 5 LINKAGE LEVER AND SPRINGS

Different types of spring are available, according to the length of the boom and certified for millions of manoeuvres. Mechanical linkage lever with adjustable mechanical stops.

## 6 LED LIGHTING

Elegant LED lighting circuit all over the aluminium head of the barrier column. Can be configured via the control unit.

## 7 ABSOLUTE MECHANICAL POSITIONER

Powerful, innovative and accurate encoder with absolute positioning, mounted on the slow reducer shaft. Allows movements to be managed in tenths of a degree, and ensures perfect automation restart without relearning after the blackout or manual release phases.

## 8 ROBUST, ELLIPTIC BOOM

Elliptical section, wind-resistant aluminium boom with central ribbing, to provide even greater stability and sturdiness. Integrated signalisation LED on the upper side. Can be configured via the control unit.

## 9 ROBUST, INNOVATIVE RELEASE

Manual mechanical release by key, with European cylinder able to release the boom for any requirement and in any situation, thanks to its excellent mechanical features.

## 10 STURDY BOOM SUPPORT FLANGE

Extended cone double flange in die-cast aluminium for support and protection, directly connected to the reduction gear with 3 internal flanges fastening system, for a sturdy and safe mechanical movement of the boom.

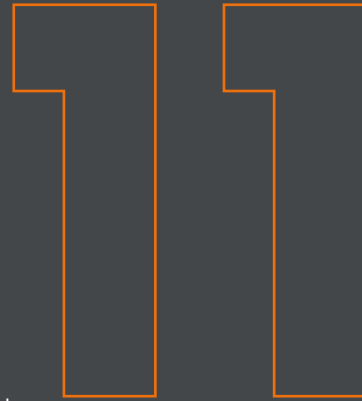

# BIONIK8

## WHY BRUSHLESS?

STURDY AND ELEGANT, TO MANAGE ACCESSES TO COMMERCIAL PREMISES,  
INDUSTRIAL SITES AND LARGE LOGISTICS AREAS

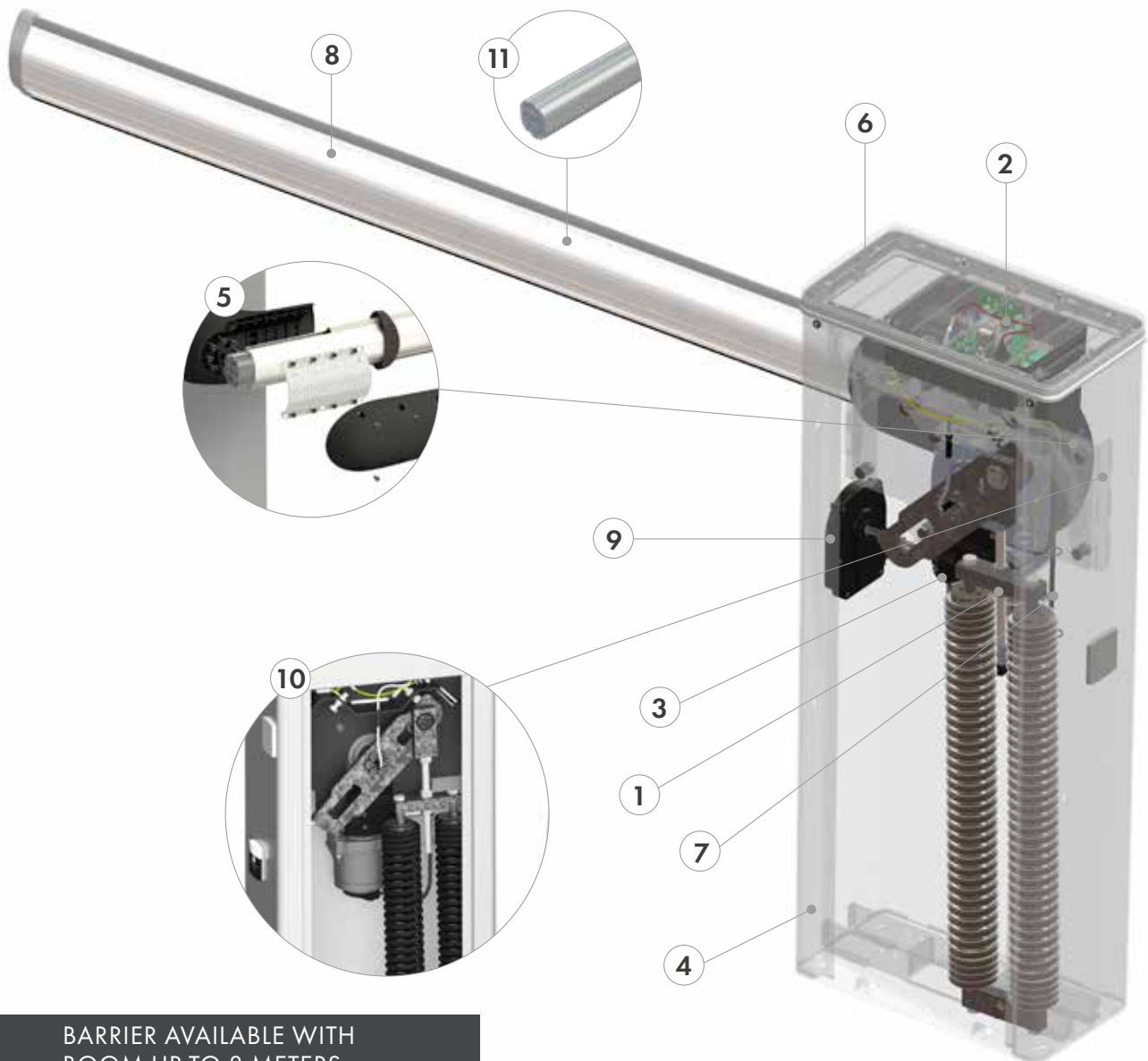

BARRIER AVAILABLE WITH  
BOOM UP TO 8 METERS

**BIONIK, EQUAL ONLY TO ITSELF**

## 1 DIGITAL 36V BRUSHLESS MOTOR

Innovative, revolutionary 36V Brushless digital motor with permanent magnetic field and a SENSORED digital technology encoder that permits unlimited use of the barrier with extremely reduced consumption and a mechanical absolute positioning system.

## 2 ADVANCED DIGITAL CONTROLLER

Easy to access, thanks to its position in the upper part of the barrier, well protected in the basket containing all the electronics, transformer compartment and support batteries. The digital controller ensures total, accurate management.

## 3 GEAR MOTOR WITH PERFECT GEARS

A veritable mechanical "gem, the gear motor is made entirely of aluminium, steel and bronze. All gears are helicoidal with a 15° tilt, assembled on top quality bearings and inserted in perfectly machined seats to guarantee absolute precision of the gear axes. The take-off of the connecting shaft to the boom is of 55 mm.

## 4 HIGHLY RESISTANT STRUCTURE

The materials employed - steel and bronze - are top quality to ensure optimum robustness for the automation, making it highly stable during use. A vital role is also played by the surface treatment and the types of varnish, designed to make the barrier structure particularly resistant to a wide range of atmospheric agents.

## 5 STURDY BOOM SUPPORT FLANGE

Extended cone double flange in die-cast aluminium for support and protection, directly connected to the reduction gear for a sturdy and safe mechanical movement of the boom.

## 6 LED LIGHTING

Elegant LED lighting circuit all over the aluminium head of the barrier column. Can be configured via the control unit.

## 7 ABSOLUTE MECHANICAL POSITIONER

Powerful, innovative and accurate encoder with absolute positioning, mounted on the slow reducer shaft. Allows movements to be managed in tenths of a degree, and ensures perfect automation restart without relearning after the blackout or manual release phases.

## 8 ROBUST, ELLIPTIC BOOM

Elliptical section 4,100 mm aluminium double boom, wind resistant, with 2 strengthening telescopic inserts to fasten the boom to the flange and to connect the 2 booms through a dedicated aluminium double joint. Integrated signalisation LED on the upper side, configurable from the control unit.

## 9 ROBUST, INNOVATIVE RELEASE

Manual mechanical release by key, with European cylinder able to release the boom for any requirement and in any situation, thanks to its excellent mechanical features.

## 10 NEW DOUBLE SPRING LINKAGE LEVER

Innovative linkage lever with toothed insert, which guarantees a correct, double and millimetric adjustment of the balancing of the 2 x 85 mm diameter springs. Hooking of the double spring to the linkage lever with roller bearing for a better distribution of the boom load points, weights and stresses.

## 11 TELESCOPIC REINFORCED SUPPORTS

Two telescopic reinforced supports inside the boom, one for fastening to the support flange and the other for the joint between the two booms, 4,100 mm long, making the boom sturdy and safe.





# BARRIER OVERVIEW

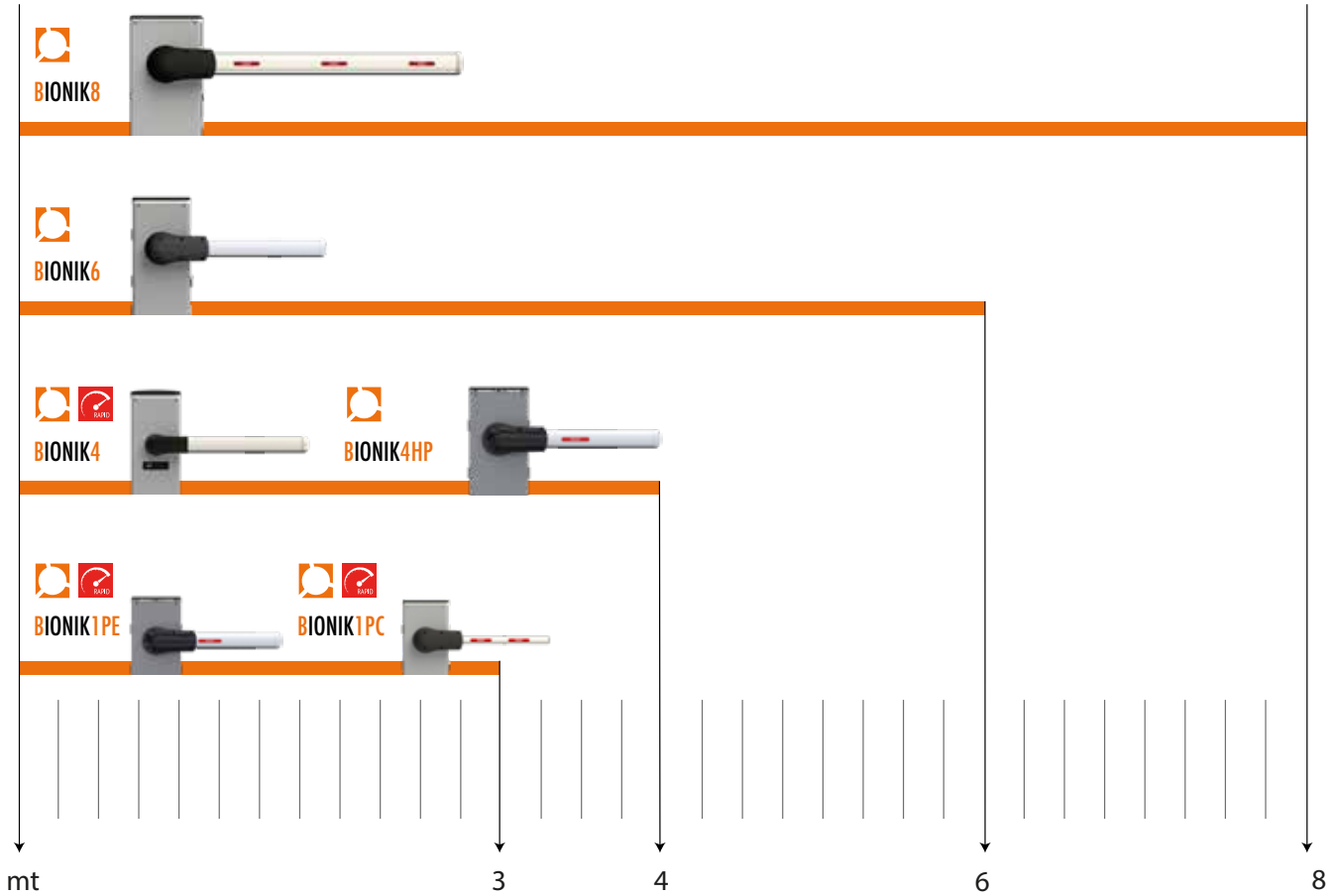

	RESIDENZIAL	COMMERCIAL	INDUSTRIAL	PARKING
BI/004				
BI/004/115				
BI/004/IS				
BI/004/IS/115				
BI/004HP				
BI/004HP/115				
BI/004HP/IS				
BI/004HP/IS/115				
BI/006				
BI/006/115				
BI/006/IS				
BI/006/IS/115				
BI/001PE				
BI/001PC				
BI/001PC/115				
BI/008				
BI/008/115				



# TECHNICAL SPECIFICATIONS

	BIONIK-4	BIONIK-4HP	BIONIK-6	BIONIK-8	BI/001PE	BI/001PC- BI/001PC/115
<b>DESCRIPTION</b>	BRUSHLESS 36V DC Barrier	BRUSHLESS 36V DC Barrier	BRUSHLESS 36V DC Barrier	BRUSHLESS 36V DC Barrier	BRUSHLESS 36V DC Barrier	BRUSHLESS 36V DC Barrier
<b>BOOM</b>	up to 4 m	up to 4 m	up to 6 m	up to 8,2 m	up to 3 m	up to 3 m
<b>LINE POWER SUPPLY</b>	230V AC - 115V AC 50/60Hz +-10%	230V AC - 115V AC 50/60Hz +-10%	230V AC - 115V AC 50/60Hz +-10%	230V AC - 115V AC 50/60Hz +-10%	230V AC 50/60Hz +-10%	230V AC - 115V AC 50/60Hz +-10%
<b>BRUSHLESS MOTOR POWER SUPPLY</b>	36V	36V	36V	36V	36V	36V
<b>MAX POWER</b>	220W	220W	220W	300W	450W	450W
<b>FREQUENCY OF USE</b>	Continuous	Super Intensive	Super Intensive	Super Intensive	Super Intensive	Continuous
<b>OPERATING TEMPERATURE</b>	-20 +55°C	-20 +55°C	-20 +55°C	-20 +55°C	-20 +55°C	-20 +55°C
<b>DEGREE OF PROTECTION</b>	IP54	IP54	IP54	IP54	IP54	IP54
<b>OPEN TIME</b>	From 1,5 to 6 s (with boom up to 3 m)	From 3 to 6 s	From 4 to 8 s	From 9 to 29 s	From 2 to 4 s	From 1 to 3 s
<b>ENCODER</b>	Absolute digital encoder	Absolute digital encoder	Absolute digital encoder	Absolute digital encoder	Absolute digital encoder	Absolute digital encoder
<b>TYOLOGY ENCODER</b>	Digital SENSORED	Digital SENSORED	Digital SENSORED	Digital SENSORED	Digital SENSORED	Digital SENSORED
<b>ONBOARD CONTROL UNIT</b>	CTRL	CTRL	CTRL	CTRL	CTRL/P	CTRL/P
<b>DAILY OPERATION CYCLES (OPEN / CLOSE - 24 HOURS NON-STOP)</b>	5000	5000	4000	2500	8000	12000
<b>PACKAGED PRODUCT WEIGHT</b>	46,2 kg	74,7 kg	75,1 kg	104,7 kg	74,7 kg	87,6 kg
<b>DIMENSIONS</b>	280 x 210 x 1.203 (L x P x H)	380 x 270 x 1237 (L x P x H)	380 x 270 x 1237 (L x P x H)	500 x 270 x 1237 (L x P x H)	380 x 270 x 1237 (L x P x H)	380 x 270 x 1237 (L x P x H)
<b>RELEASE</b>	Handle with a twin-acting elliptical lever and key with a STANDARD cylinder	Release of reduction gear on bearings, with European cylinder key	Release of reduction gear on bearings, with European cylinder key	Release of reduction gear on bearings, with European cylinder key	Release of reduction gear on bearings, with European cylinder key	Release of reduction gear on bearings, with European cylinder key
<b>EXP B-CONNECT INPUT PREDISPOSITION</b>	√	√	√	√	√	√
<b>NUMBER OF PACKAGES PER PALLET</b>	8	6	6	4	6	6



Brushless  
Motor



Intensive  
Use



High Speed  
Motor



Reversible  
Motor

## PACKAGING BIONIK4

**L.: 28 cm**  
**P.: 21 cm**  
**H. 120,3 cm**

## PACKAGING BIONIK8

**L.: 50 cm**  
**P.: 27 cm**  
**H. 123,7 cm**

## PACKAGING BIONIK1/4HP/6

**L.: 38 cm**  
**P.: 27 cm**  
**H. 123,7 cm**

# FUNCTIONS

## OF BIONIK BARRIERS

DESCRIPTION	BIONIK 4	BIONIK 4HP
<b>BOOM LENGHT</b>	<b>UP TO 4 M</b>	<b>UP TO 4 M</b>
<b>ONBOARD DIGITAL CONTROLLER</b>	CTRL	CTRL
<b>RADIO RECEIVER TYPE</b>	H93/RX20/1 and H93/RX22A/1 with fixed code connection H93/RX2RC/1 with rolling code connection	H93/RX20/1 and H93/RX22A/1 with fixed code connection H93/RX2RC/1 with rolling code connection
<b>MOTOR POWER SUPPLY</b>	36V DC	36V DC
<b>MOTOR MANAGEMENT TECHNOLOGY (ETC)</b>	SENSORED technology	SENSORED technology
<b>ENCODER TYPE</b>	Magnetic Digital SENSORED, 4096 pulses per revolution	Magnetic Digital SENSORED, 4096 pulses per revolution
<b>MAINS POWER SUPPLY</b>	230V 50/60 Hz	230V AC - 115V AC 50/60Hz
<b>BATTERY OPERATION</b>	(optional) 2 internal batteries 12V DC 4,5 Amp/h	(optional) 2 internal batteries 12V DC 4,5 Amp/h
<b>ENERGY CONSUMPTION</b>	Very low consumption	Very low consumption
<b>NUMBER OF MOTORS</b>	1	1
<b>POWER SUPPLY FOR ACCESSORIES</b>	24V DC	24V DC
<b>FLASHING LIGHT BARRIER TYPE (INCLUDED)</b>	24V DC LED	24V DC LED
<b>FLASHING LIGHT BOOM TYPE</b>	24V DC LED - Strip led, lenght 4 m	24V DC LED - Strip led, lenght 4 m
<b>OUTPUT FOR BARRIER OPENING INDICATOR AND AUTOMATION SYSTEM ON WARNING LIGHT</b>	√	√
<b>OUTPUT FOR COURTESY LIGHT</b>	40W	40W
<b>TIMED AND GUARANTEED AUTOMATIC CLOSING</b>	√	√
<b>GATE EDGE SAFETY MANAGEMENT, 8.2KΩ OR STANDARD</b>	√	√
<b>LIMIT SWITCH TYPE</b>	Adjustable open and closed position Mechanical travel limits	Adjustable open and closed position Mechanical travel limits
<b>FORCE ADJUSTMENT IN NOMINAL MOVEMENT</b>	√	√
<b>FORCE ADJUSTMENT IN START-UP AND DECELERATION</b>	√	√
<b>OBSTACLE DETECTION (ALSO IN POSITION RECOVERY MODE) - MOTOR REVERSAL</b>	√	√
<b>OPENING AND CLOSING SPEED SETTING</b>	√	√
<b>DECELERATION DURING OPENING AND CLOSING</b>	√	√
<b>OPENING AND CLOSING APPROACH DISTANCE SETTING</b>	√	√
<b>STARTING ACCELERATION (SOFT-START) FOR OPENING AND CLOSING MANOEUVRES</b>	√	√
<b>SAFEGUARDED CLOSURE/OPENING FUNCTION</b>	√	√
<b>STOPPING SPACE AND MOTOR BRAKING</b>	√	√
<b>PARTIAL OPENING CONTROL MASTER/SLAVE MODE</b>	√	√
<b>HUMAN PRESENCE CONTROL</b>	√	√
<b>CONDOMINIUM FUNCTION</b>	√	√
<b>SAFETY DEVICE CONFIGURATION</b>	√	√
<b>INSTALLATION TEST FUNCTION</b>	(prog button)	(prog button)
<b>OPERATING TEMPERATURE</b>	-20°C/+55°C	-20°C/+55°C
<b>INVERTER THERMAL PROTECTION</b>	√	√
<b>MAGNETIC ELECTRO-LOCK MANAGEMENT</b>	(optional) √	(optional) √
<b>DETECTOR LOOP MANAGEMENT</b>	(optional) √	(optional) √
<b>CLOCK FUNCTION (INCLUDED)</b>	√	√
<b>PARKING ACCESS MODE FUNCTION (INCLUDED)</b>	√	√
<b>EXTERNAL STATUS TYPE OUTPUT SETTING</b>	(optional) √	(optional) √
<b>RESTORE FACTORY DEFAULT VALUES</b>	√	√
<b>INFORMATION ON USE OF MOTOR</b>	√	√
<b>SECURITY PASSWORD MANAGEMENT</b>	√	√
<b>ENABLING OF ANTI-BREAKING THROUGH SYSTEM</b>	√	√



# DIMENSIONS

## BIONIK4

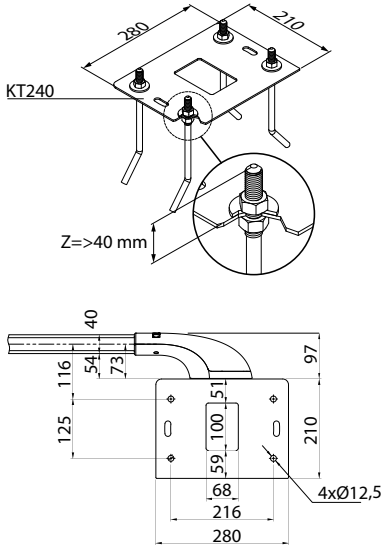
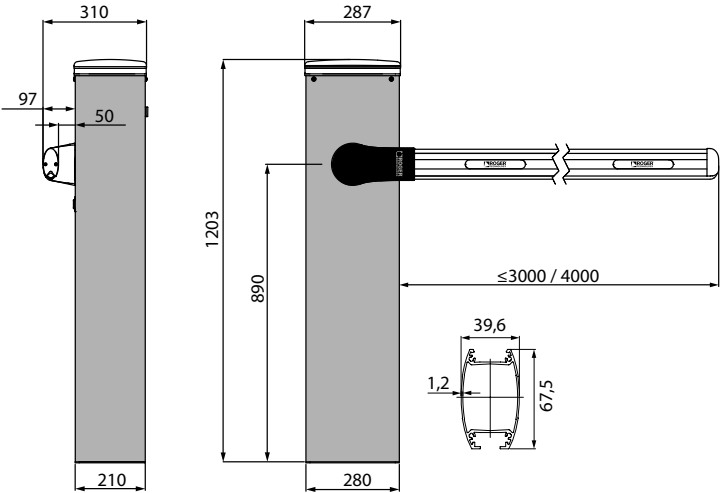

## BIONIK4HP

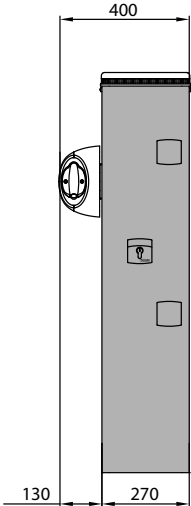

## BIONIK6

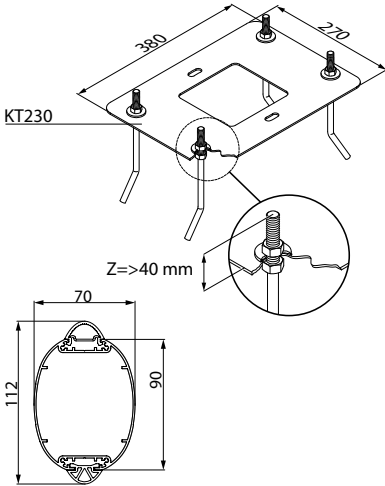
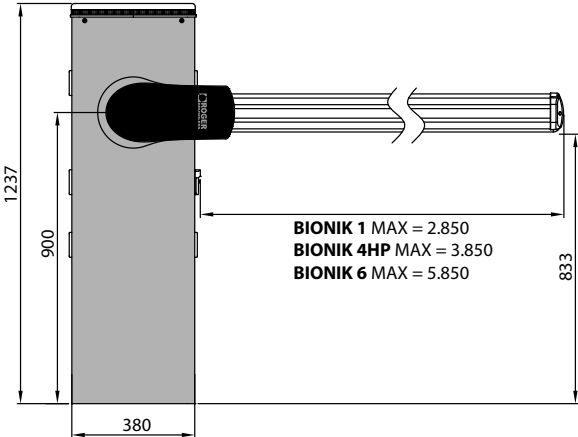



# 19



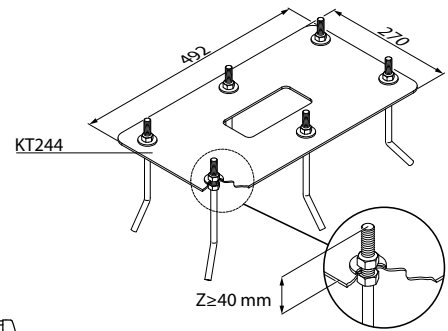
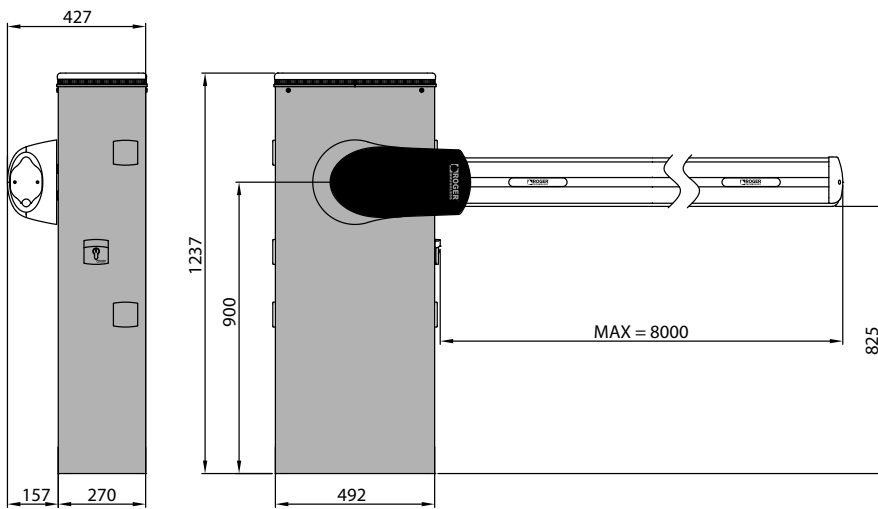



BIONIK8





			BI/004 BI/004/115	BI/004/IS BI/004/IS/115	BI/004HP BI/004HP/115	BI/004HP/IS BI/004HP/IS/115	BI/006 BI/006/115	BI/006/IS BI/006/IS/115	BI/001PE	BI/001PC BI/001PC/115	BI/008 BI/008/115
	<b>B73/LTM</b>	RGB boom light and traffic light control device for CTRL.	✓	✓	✓	✓	✓	✓			✓
	<b>BA/60/3</b>	White painted cylindrical aluminium bar 3 meters length								✓	
	<b>BA/68/3</b>	White painted aluminum rod, 3 meters long, with LED cover profile and impact resisting rubber profile	✓	✓							
	<b>BA/68/4</b>	White painted aluminum rod, 4 meters long, with LED cover profile and impact resisting rubber profile	✓	✓							
	<b>BA/91/3</b>	White painted aluminum rod, 3 meters long, with LED cover profile and impact resisting rubber profile.			✓	✓	✓	✓	✓		
	<b>BA/91/4</b>	White painted aluminum rod, 4 meters long, with LED cover profile and impact resisting rubber profile.			✓	✓					
	<b>BA/91/6</b>	White painted aluminum rod, 6 meters long, with LED cover profile and impact resisting rubber profile.					✓	✓			
	<b>BA/128/4</b>	White painted aluminum rod, 4 meters long, with LED cover profile and impact resisting rubber profile									✓
	<b>BAFS/01</b>	Fixed support for bars	✓	✓	✓	✓	✓	✓			✓
	<b>BAFS/02</b>	Fixing support, adjustable	✓	✓	✓	✓	✓	✓			✓
	<b>BAFS/03</b>	Fixing support with bolt predisposition for bars	✓	✓	✓	✓	✓	✓			✓
	<b>BAFS/04</b>	Fixing support adjustable, with bolt predisposition for bars	✓	✓	✓	✓	✓	✓			✓
	<b>BAFS/05</b>	Adjustable fixed support with vandal-proof magnetic suction cup complete with B72/DGS demagnetizer card	✓	✓	✓	✓	✓	✓			✓

			BI/004 BI/004/115	BI/004/IS BI/004/IS/115	BI/004HP BI/004HP/115	BI/004HP/IS BI/004HP/IS/115	BI/006 BI/006/115	BI/006/IS BI/006/IS/115	BI/001PE	BI/001PC BI/001PC/115	BI/008 BI/008/115
	<b>BAMS/01</b>	Mobile support for bars	✓	✓	✓	✓	✓	✓			✓
	<b>BAMS/01/EXT</b>	Extension 20cm for mobile support BAMS/01	✓	✓	✓	✓	✓	✓			✓
	<b>BARK/02</b>	Barrier skirting in aluminum, with stainless steel screws mounted on bronze bushings. Single module of length 2 meters	✓	✓	✓	✓	✓	✓			✓
	<b>BI/BAT/KIT</b>	Kit for emergency batteries charger for brushless digital controller CTRL 36V DC with plug-in card, with 2 recovery batteries 12V DC, 4.5 Ah. Kit for BIONIK barrier	✓	✓	✓	✓	✓	✓	✓	✓	✓
	<b>BI/BCHP</b>	Plug-in card, batteries charger, for brushless digital controller CTRL 36V DC, without recovery batteries, for BIONIK barrier	✓	✓	✓	✓	✓	✓	✓	✓	✓
	<b>BT12V45</b>	Battery 12V 4.5 Ah	✓	✓	✓	✓	✓	✓	✓	✓	✓
	<b>CRA/BAR</b>	Post for photocells G90/F2ES - G90/F4ES - for spaced installation on a barrier cabinet (+23cm)			✓	✓	✓	✓	✓	✓	✓
	<b>CRA/BAR/M90</b>	Post for photocells M90/F2ESO - M90/F4ESO for spaced installation on a barrier cabinet (+23 cm).			✓	✓	✓	✓	✓	✓	✓
	<b>DLD1/24</b>	Loop detector for 1 loop, 2 output, 24V AC/DC	✓	✓	✓	✓	✓	✓	✓	✓	✓
	<b>DLD2/24</b>	Loop detector for 2 loop, 2 output + output alarm, 24V AC/DC	✓	✓	✓	✓	✓	✓	✓	✓	✓
	<b>JNT/BA/91</b>	Internal boom bar joint in anodized aluminum including fixing screws for bars BA/91.			✓	✓	✓	✓	✓		
	<b>JNT/BA/128</b>	Internal boom bar joint in anodized aluminum including fixing screws for bars BA/128									✓
	<b>KT230</b>	Fixing plate with stay bolts and screws for BI/001PE - BI/001PC - BI/004HP - BI/006			✓		✓		✓	✓	

			BI/004 BI/004/115	BI/004/IS BI/004/IS/115	BI/004HP BI/004HP/115	BI/004HP/IS BI/004HP/IS/115	BI/006 BI/006/115	BI/006/IS BI/006/IS/115	BI/001PE	BI/001PC BI/001PC/115	BI/008 BI/008/115
	<b>KT230/IS</b>	Fixing plate, inox AISI 304 version, with stay bolts and screws for BI/001PE - BI/001PC - BI/004HP - BI/006				✓		✓			
	<b>KT231</b>	Fixing plate for code BAFS/01, BAFS/02, BAFS/03, BAFS/04, BAFS/05	✓	✓	✓	✓	✓	✓			
	<b>KT239</b>	Kit DIN rail with magnetic support	✓		✓		✓		✓	✓	✓
	<b>KT240</b>	Fixing plate with stay bolts and screws for series Bionik	✓								
	<b>KT240/IS</b>	Fixing plate, inox AISI 304 version, with stay bolts and screws for BI/004.		✓							
	<b>KT244</b>	Fixing plate with stay bolts and screws for BI/008									✓
	<b>KT242</b>	Cable passage kit, with magnetic support, for barriers	✓		✓		✓		✓	✓	✓
	<b>R99/BASB20</b>	Pack of 20 stickers for barrier	✓	✓	✓	✓	✓	✓	✓	✓	✓
	<b>RL670</b>	European cylinder key for release system series SMARTY - BIONIK	✓	✓							
	<b>SND/BA/68/DW</b>	Articulated joint 90° with lower tie rod for boom arms BA/6	✓	✓							
	<b>SND/BA/68/UP</b>	Articulated joint 90° with upper tie rod for boom arms BA/68	✓	✓							
	<b>SND/BA/68/UP/RD</b>	Articulated joint 90° with upper tie rod (lowered version) for boom arms BA/68	✓	✓							
	<b>SND/BA/91/DW</b>	Articulated joint 90° with lower tie rod for boom arms BA/91.			✓	✓			✓		





# BIONIK

THE BRUSHLESS AUTOMATIC BARRIER  
FROM DIGITAL THINKING

*Illuminated and moving boom barrier*

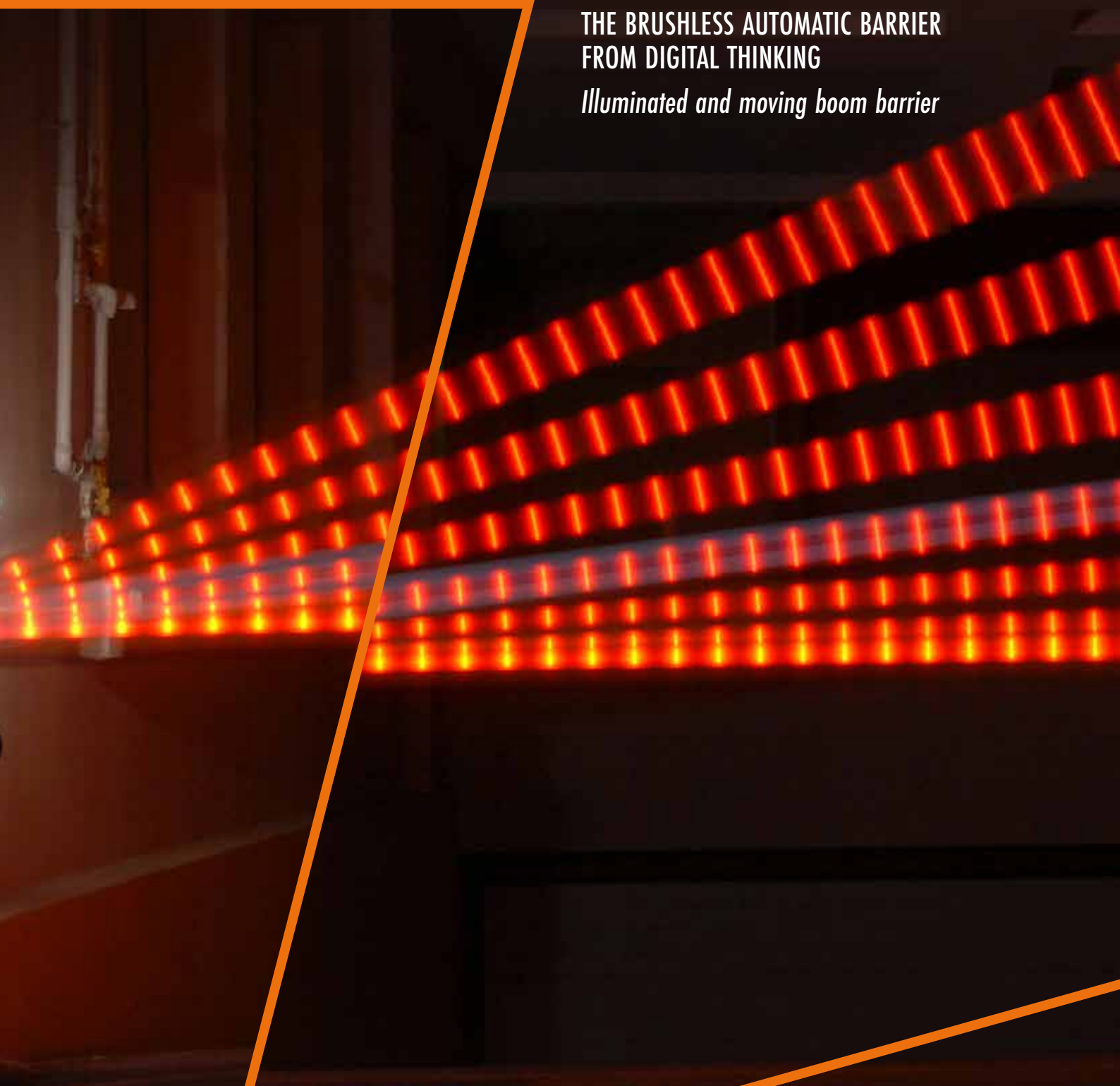

# STANDARD INSTALLATION

A PRACTICAL EXAMPLE FOR YOUR SUCCESSFUL INSTALLATION

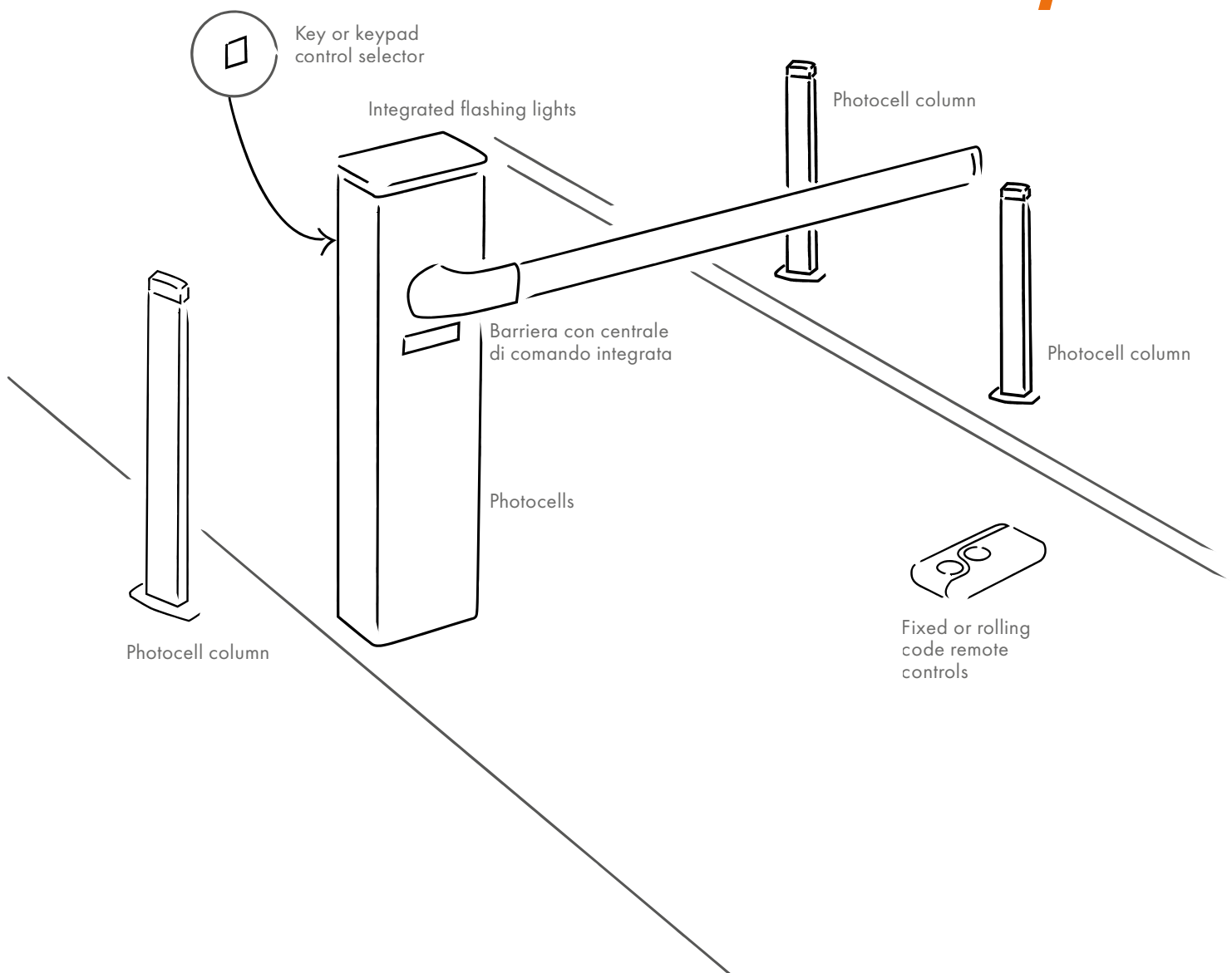

# 27



AUTOMATIC BARRIER



**PREMIUM DEALER / PROFESSIONAL DEALER**



immagine ASSOCIATI  F99/E/019EN - 06/2023



Via S. Botticelli, 8  
31021 Bonisolo di Mogliano Veneto (TV) · ITALY  
T. +39 041 5937023 · F. +39 041 5937024  
**WWW.ROGERTECHNOLOGY.COM**

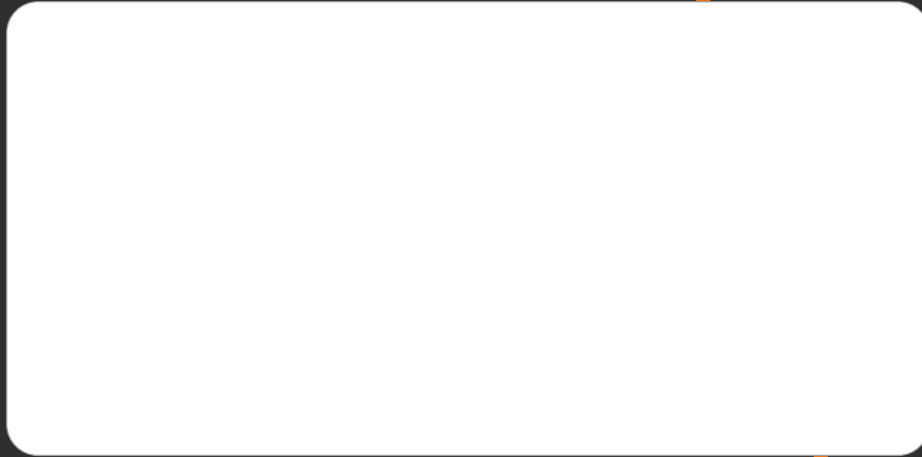