



QUFRESH

Fresh Air is Better Air

100 Washington Rd Mineral Wells, TX 76067

BC80

Bathroom Ventilator Specifications

BLOWER:

- Plug-in, permanently lubricated PSC motor - engineered for continuous operation
- Dynamically balanced centrifugal blower wheel for quiet, efficient performance
- Low RPM for quiet operation

HOUSING:

- Rugged, galvanized steel construction
- 4" round ducting
- Polymeric duct connector and no metallic clatter
- 5-3/4" height allows for 2" x 8" (nominal) joist installations
- Includes mounting tabs and hanger bars to position housing anywhere between 16" to 24"-on-center joists
- 1/2" electrical connection (Knock out)

GRILLE:

- Polymeric construction
- Fast, Easy, spring installation

Accessories:

- Humidity Sensor Model BCHUMSR
- Motion Sensor Model BCMOTSR
- Ceiling Radiation Damper BGCRD

Available as Contractor Packs

- Housing rough-in BC4A
- Trim Kit B80B

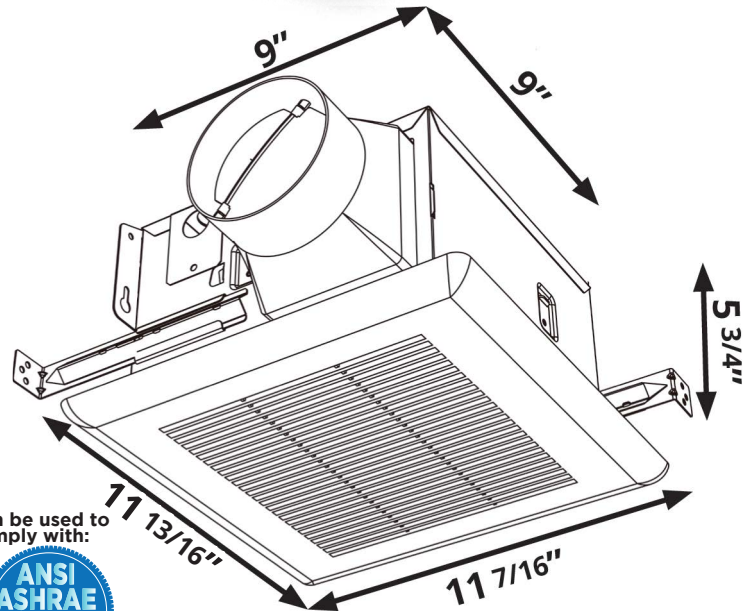

ETL Listed for use over bathtubs and showers when connected to a GFCI protected branch circuit (ceiling mount only).

EXPANDED PERFORMANCE

	Static Pressure (Inches of w.g.)							Fan Speed RPM	Maximum Fan Watts	Amps
	0.00	0.10	0.15	0.20	0.25	0.30	0.35			
Air Flow CFM	88	80	74	68	62	57	52	880	16.2	0.2
Sones		<0.3			0.9					

REFERENCE	QTY	REMARKS	Project
			Location
			Architect
			Engineer
			Contractor
			Submitted By
			Date