



..always innovative!®

TRANSPORT RECOMMENDATIONS

Can-Am Spyder

2017 CAN-AM SPYDER F3-S
shown for reference

FRONT TIRES:
165/55 R15

104" L x 58.9" W

REAR TIRE:
225/50 R15

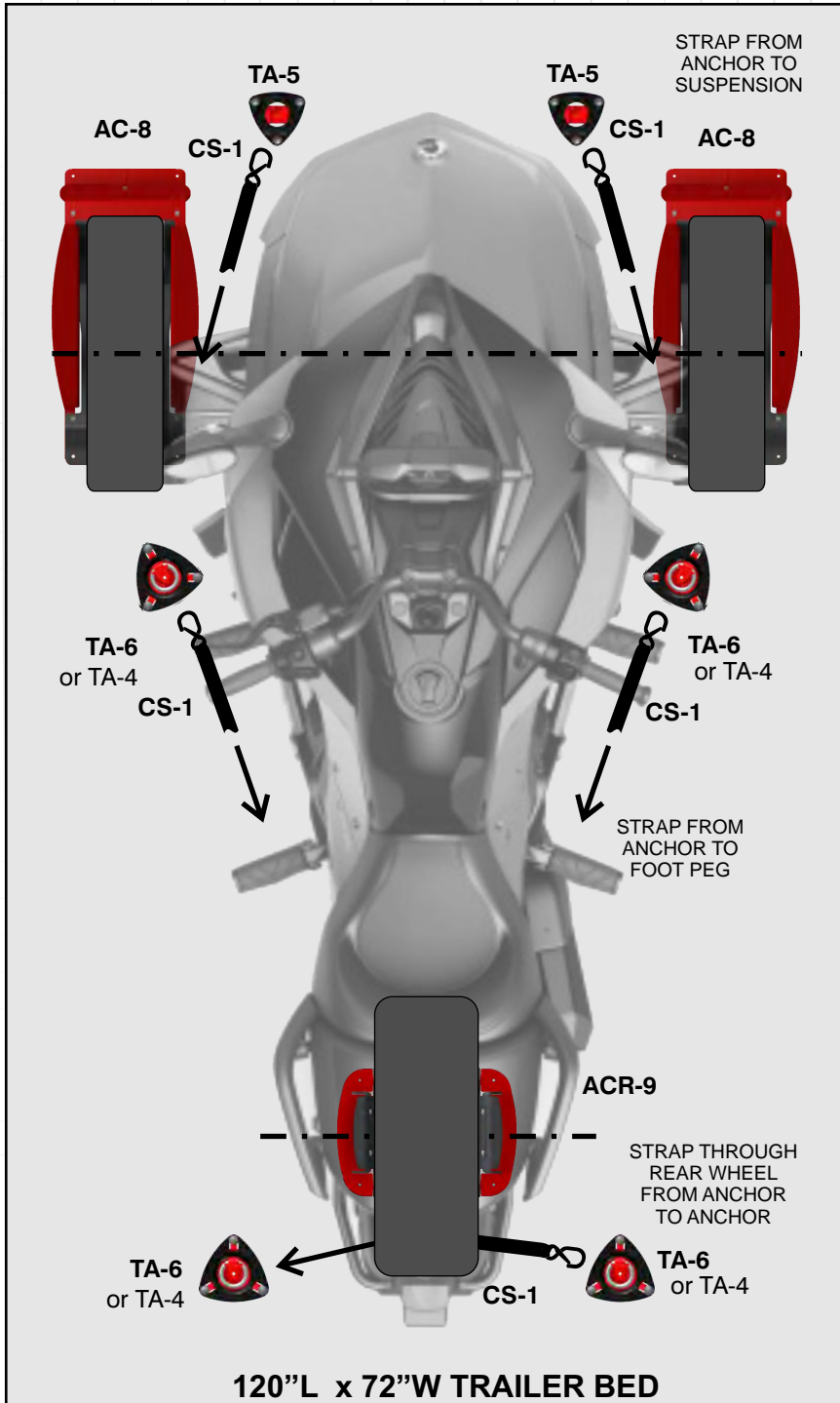

TA-6: RECESSED ROTATING RING ANCHOR

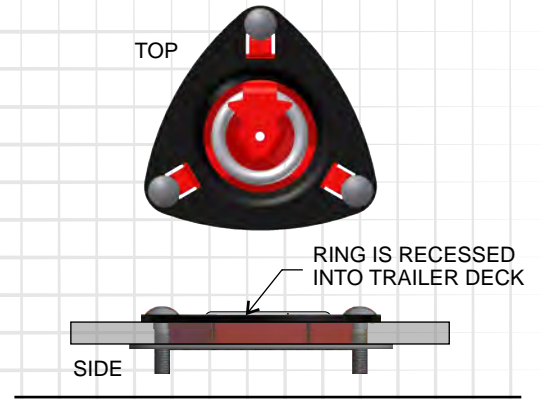

TA-5: ROTATING ANCHOR

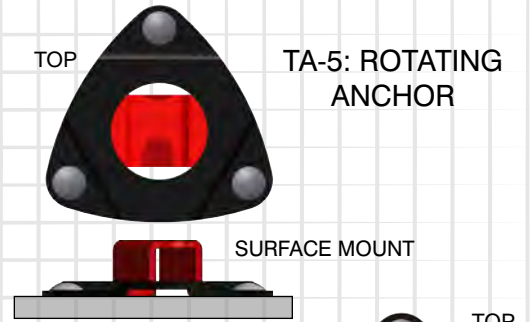

TA-4: ROTATING RING ANCHOR

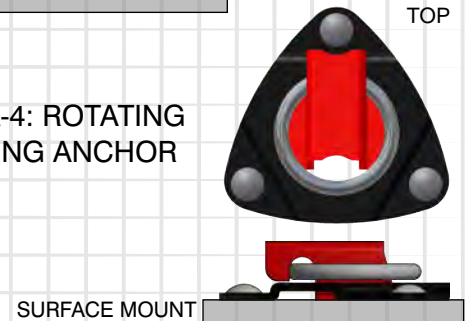

AC-8: ALUMINUM WHEEL CHOCK

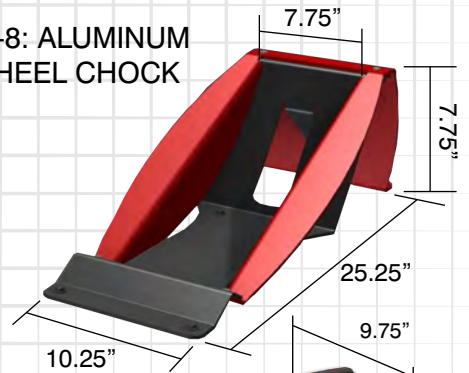

ACR-9: REAR ALUMINUM WHEEL CHOCK

