

XiV



XiV | MEDIA PLAYER COMPUTER MODULE IP50 UNIT

DYNICS XiV is a compact computer built with no moving parts and equipped with an aluminum heatsink in an IP50 sealed form factor, featuring an 8th Gen Hexa™ Core i5 / i7 processor. With your choice of operating system, storage and Wi-Fi, the XiV can be configured to suit your production applications.

- Fanless (No Moving Parts)
- Aluminum Heatsink
- 24VDC Power Entry / AC Option
- Optional - Single or Dual Wi-Fi 2.4 / 5GHz Wireless 802.11 a/g/n
- IP50 Rating

PC SPECIFICATIONS

| | |
|---------------------------|---|
| COMPUTER I/O PORTS | 1x DVI-D Port 2x Display Port v1.2 4x USB 3.1 Ports 4x USB 2.0 2x 1Gb Ethernet Ports (1x Supports vPro AMT) 2x RS232 2x PS/2 2x Audio Jacks (Line-In/Line-Out) |
| CPU | Intel® Hexa Core™ i5 8500T / i7 8700T |
| CPU SPEED | i5 – Up to 3.5 GHz, 9MB Cache i7 – Up to 4.0 GHz, 12MB Cache |
| MEMORY | Up to 32GB DDR4 |
| STORAGE | 240GB – 2TB SSD / 1TB HDD |
| OPERATING SYSTEM | -Windows® 10 Enterprise IoT LTSB 2016 (64-bit) -Windows® 10 Enterprise IoT LTSC 2019 (64-bit) - Windows® 10 Pro (64-bit) -Linux Ubuntu |
| POWER SUPPLY | 24VDC Power Entry (3-Pin Quick Disconnect Included) / 100 ~ 240VAC |
| OPTIONAL | Single or Dual Wi-Fi 2.4 / 5GHz Wireless 802.11 a/g/n |
| TEMPERATURE | Operating: 0°-50°C 32°-122°F |
| RELATIVE HUMIDITY | Non-Operating: -25°-60°C -13°-140°F Non-Condensing: 20% - 80% |
| SHOCK RESISTANCE | Operating: 10G Non-Operating: 15G |
| VIBRATION | Operating: 1.0G from 57~2000Hz Non-Operating: 2.5G from 57~2000Hz |
| COMPLIANCE | EU: RoHS Directive 2011/65/EU, EN 50581, EMC Directive 2014/30/EU, EN 61326-1, Low Voltage Directive 2014/35/EU, EN 61010-1+EN 61010-2-201 |
| WARRANTY | 24-Month limited warranty. Extended warranty available, contact DYNICS for more details. |



XiV



DIMENSIONS, WEIGHT AND POWER CONSUMPTION

| | HEIGHT | WIDTH | DEPTH | WEIGHT | POWER CONSUMPTION |
|------------|------------------|-------------------|--------------------|----------|-------------------|
| XiV | 3.6" (92.5mm) | 9.6" (244.0mm) | 11.3" (287.3mm) | 13 lbs.* | 60 Watts** |

* Weights are approximate, contact DYNICS for details.

** Power consumption is based on maximum ratings, actual ratings vary significantly based on components used.

MECHANICAL DRAWINGS (Drawings with optional Dual Wi-Fi 2.4 / 5GHz Wireless 802.11 a/g/n)

FRONT VIEW

BACK VIEW

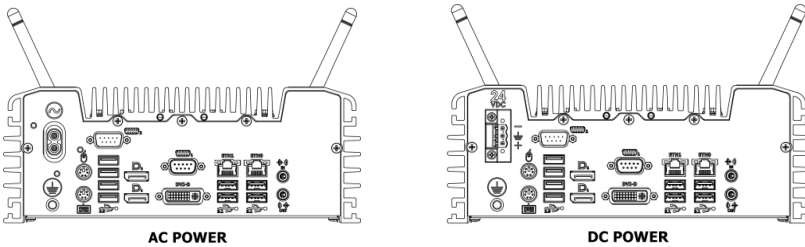

AC POWER

DC POWER

TOP VIEW

BOTTOM VIEW

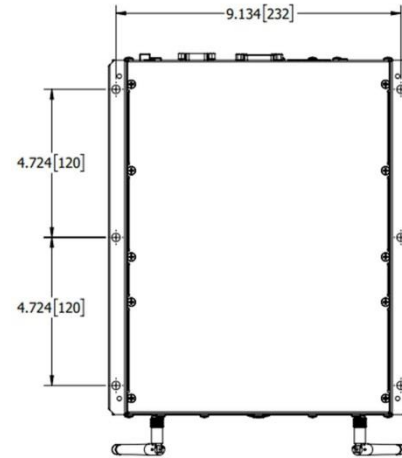
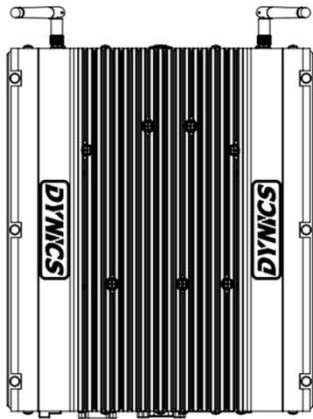

LEFT SIDE VIEW

RIGHT SIDE VIEW

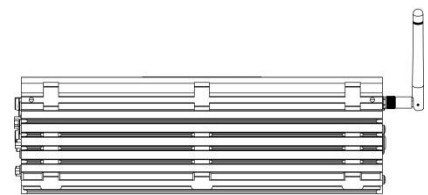
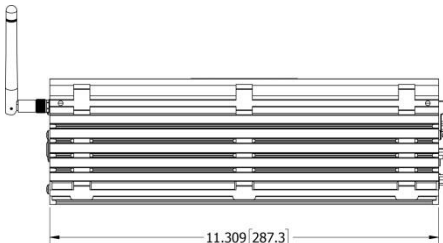

All measurements are in inches and pounds, , unless noted. Pictures and drawings are not to scale. Estimated weight may change depending on options. DYNICS Reserves the right to change, modify, upgrade, or discontinue any part of this datasheet without any prior notice.

