

DATA SHEET

MightyMount®

STRONGARM's "Light" Industrial Mounting That's HEAVY Duty

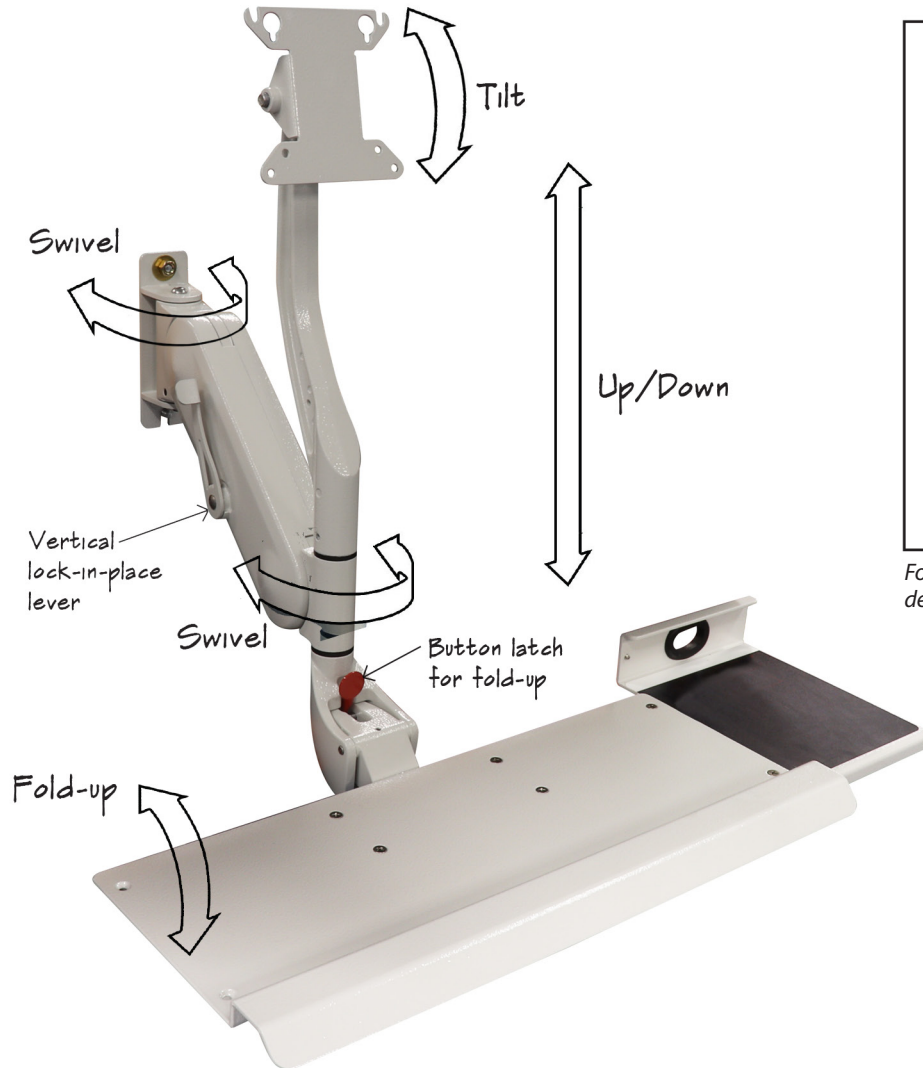

Fold-up Keyboard Version with 21" widescreen desktop display, keyboard, and mouse

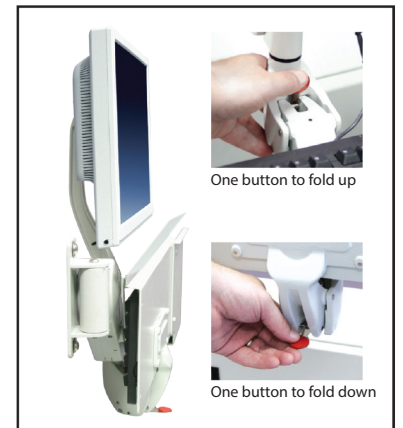

One button to fold up

One button to fold down

Ergonomic Adjustability

- Counterbalance provides smooth and effortless adjustment
- Unique linkage keeps the display and keyboard level throughout travel
- Lever actuated lock-in-place for a secure and stable platform

Machinery Grade Construction

- Significantly different from "office grade" products
- Precision milled, die-cast aluminum structure
- Idea for machine builders and discriminating end users

Extensive Customization

- However you need it...we can build it
- OEMs rest assured, guaranteed lifetime supply

MightyMount[®]

Articulation (Shown with 21" Widescreen Desktop Display)

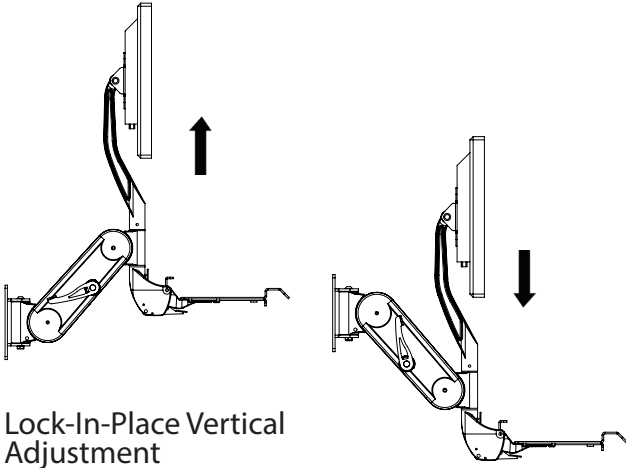

Lock-In-Place Vertical Adjustment

12" or 16" of ergonomic vertical adjustment is gas spring counterbalanced with positive lock-in-place via side lever

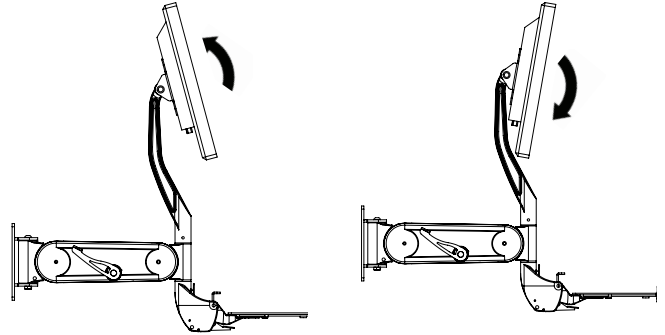

Display Tilt

Forward 15°, backward 45° with adjustable friction

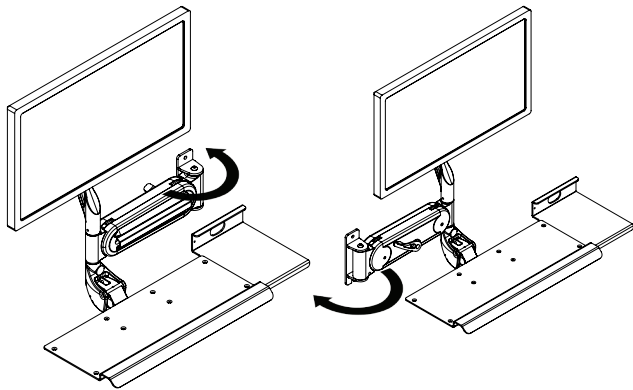

180° Rotation Around Mounting Point

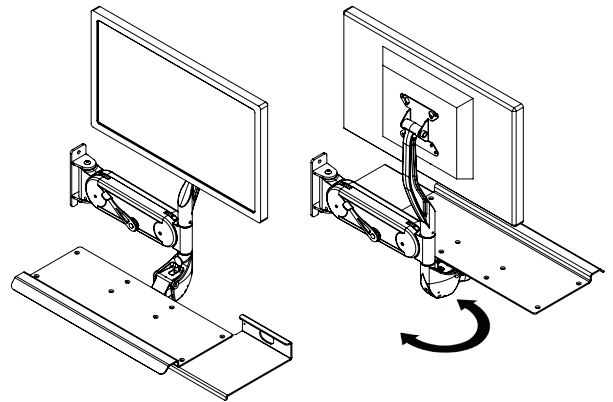

180° Display/Keyboard Rotation

(Independent display and keyboard rotation available)

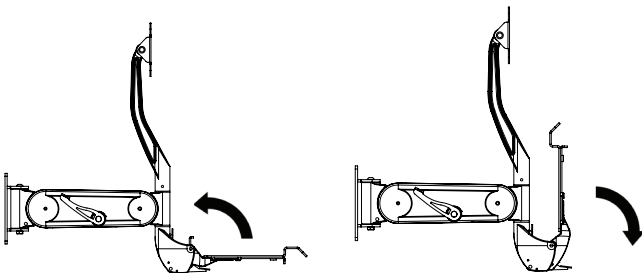

Fold-Up Keyboard Tray

With simple button latch release

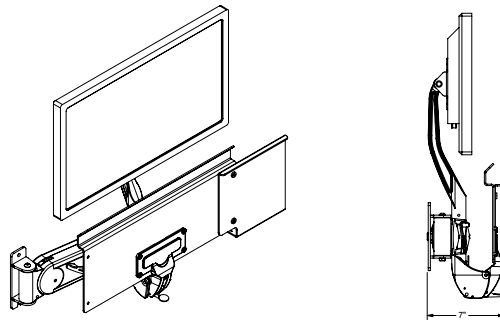

Stows to Just 7" From the Wall

MightyMount[®]

Dimensions of Catalog #MM4-W12F

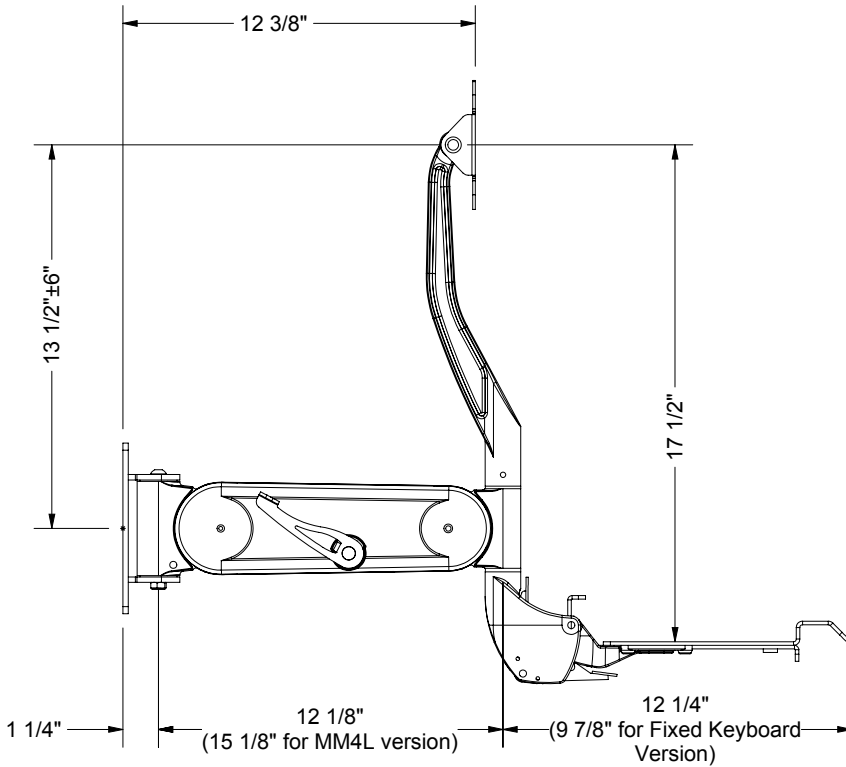

Surface Mounting

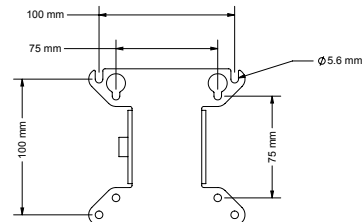
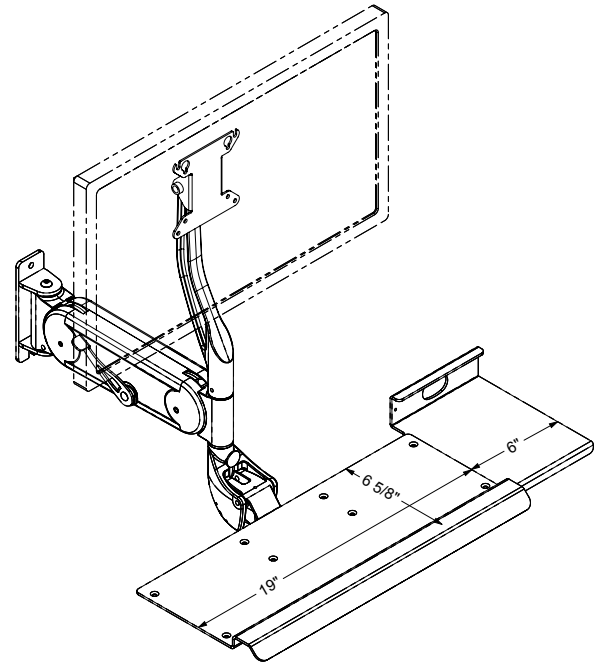

Display Mounting
(Standard VESA displays)

Specifications

Materials of Construction

Body – Cast 319F Aluminum Alloy
 Keyboard Tray – 5052 Aluminum Alloy
 Mounting and Display Bracket – Mild Steel

Bearings

Horizontal Axles – Precision Ground Ball Bearings
 Vertical Axles – Acetal Polymer Bushings

Maximum Counterbalance

32 lbs. (26 lbs. with MM4L Version)

Finish

Textured Powder Coat RAL 7035 Light Gray Standard,
 Other Stock Colors Available
 Custom Colors and Finishes Are Also Available

Cable Management

Screw down stainless steel cover. (Actual size profile)

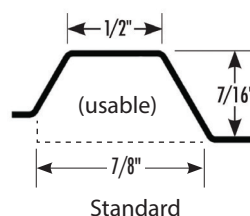

Standard

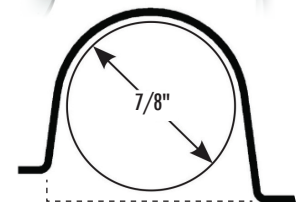

Optional Oversize
(Accepts 7/8" flexible loom)

MightyMount®

Customization Samples

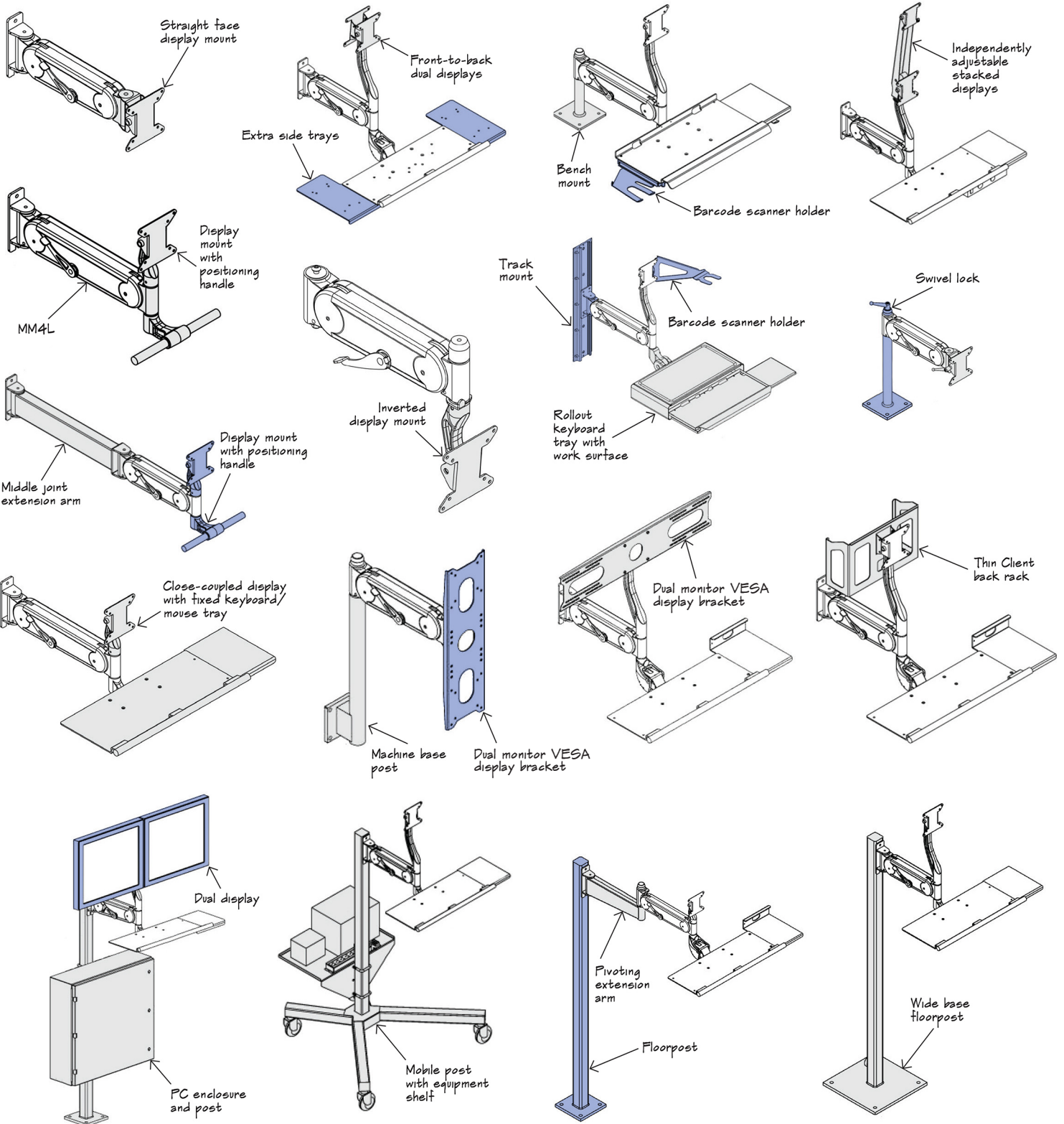

MightyMount®

Customization Samples

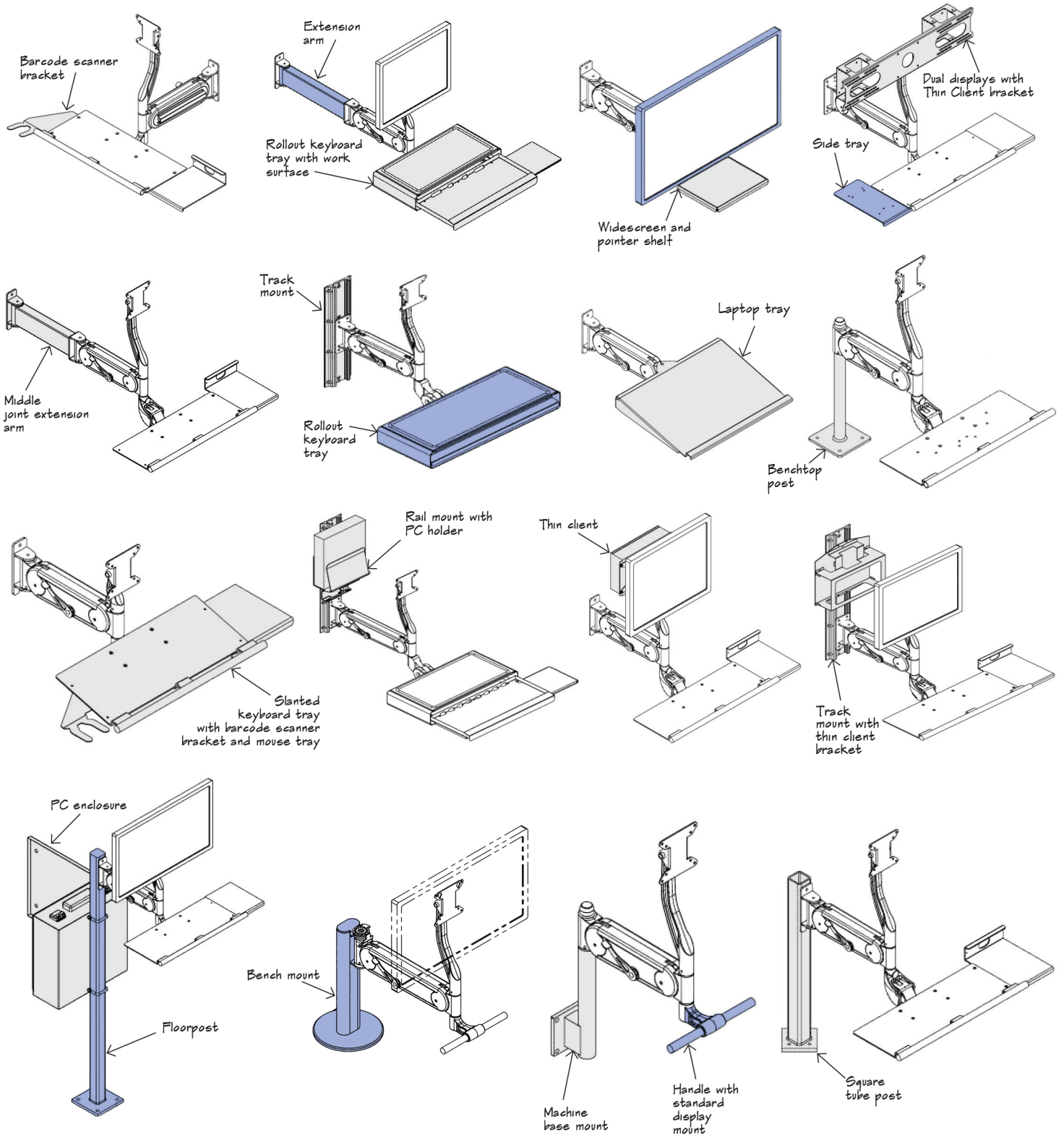

DATA SHEET

MightyMount[®]

Sketch Starter for Your Ideas

