

12V C.C. - D.C.

VA08-AP71/LL-53A  
VA08-AP71/LL-53S

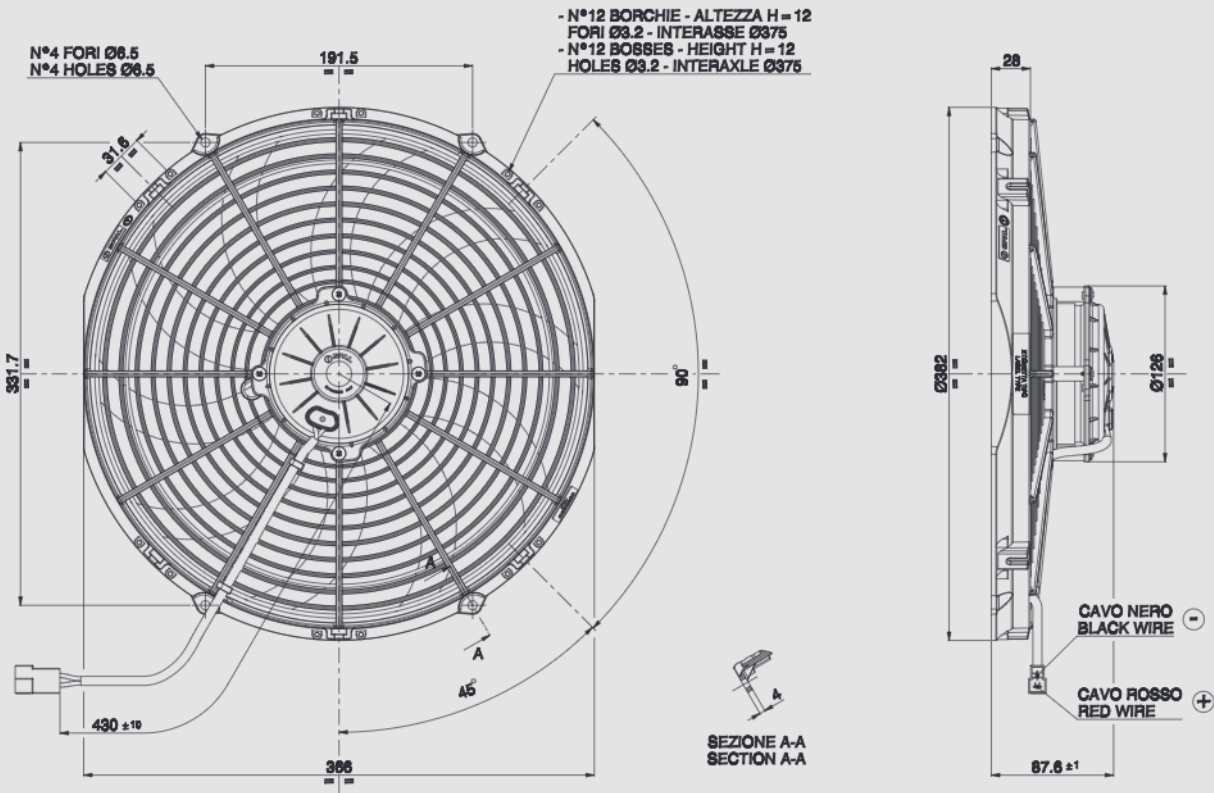

AMP connector Code 180908  
AMP terminal Code 42098-2  
Suggested mounting torque: 3(+1/-0) Nm with screw M5  
Weight 2,35 Kg. approx.

Connettore AMP Cod. 180908  
Terminali AMP Cod. 42098-2  
Coppia di serraggio consigliata: 3(+1/-0) Nm con vite M5  
Peso 2,35 Kg. circa

Ø 350 mm

Ø 14"

suction / aspirante

blowing / soffiante

PRODUCT FEATURES  
CARATTERISTICHE PRODOTTO

Static pressure Pressione statica mm H <sub>2</sub> O	suction / aspirante			blowing / soffiante			Static pressure Pressione statica in H <sub>2</sub> O
	Airflow Portata m <sup>3</sup> /h	Current input Corrente assorbita A	Airflow Portata CFM	Airflow Portata m <sup>3</sup> /h	Current input Corrente assorbita A	Airflow Portata CFM	
0	3160	19,5	1864	3120	21,1	1841	0
2,5	2970	20,1	1752	2980	21,2	1758	0,1
5	2750	20,5	1623	2760	21,3	1628	0,2
7,5	2500	20,5	1475	2340	21,0	1381	0,3
10	2010	19,6	1186	2110	21,0	1245	0,4
12,5	1650	18,7	974	1.680	20,4	991	0,5
15	1380	19,1	814	1200	19,8	708	0,6
17,5	1050	19,8	620	310	19,9	183	0,7
20	820	21,1	484	390	20,5	230	0,8
22,5	420	21,4	248	0	20,8	0	0,9
25	0	21,5	0				1

Waterproof motor, IP 68 Motore chiuso, IP 68	✓
Low noise / Bassa rumorosità	✓
Long life / Lunga durata	✓
VLL version* / Versione VLL*	✓
Waterproof connector Connettori a tenuta stagna	✓
Accessories: all the fixing kits Accessori: tutti i kit di fissaggio	✓

\* for OEM applications only.  
\* per applicazioni OEM

✓ = Standard feature  
Caratteristiche standard  
✓ = Available upon request  
Disponibile su richiesta

Test voltage 13 V. d.c. - Tensione di prova 13 V. c.c.