

**24V** C.C. - D.C.

**VA59-BP70/LL-68A**  
**VA59-BP70/LL-88S**

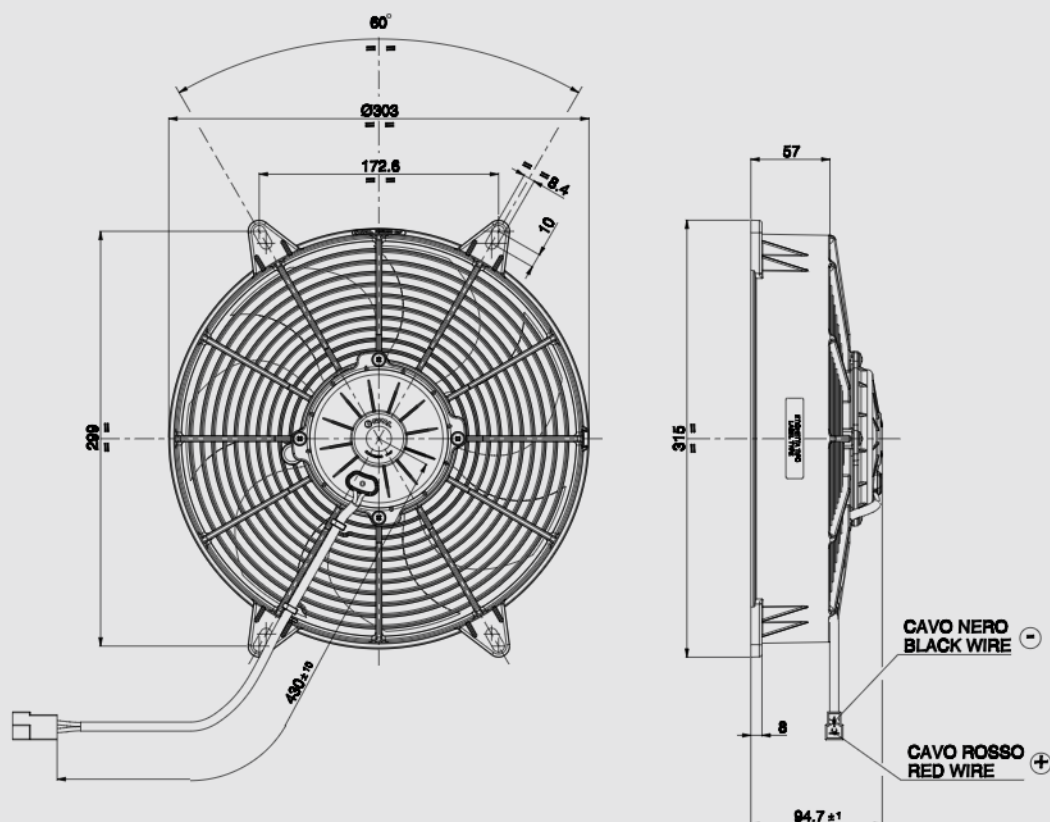

AMP connector Code 180908  
AMP terminal Code 42098-2  
Suggested mounting torque: 3(+1/-0) Nm with screw M8  
Weight 2.41 Kg. approx.

Connettore AMP Cod. 180908  
Terminali AMP Cod. 42098-2  
Coppia di serraggio consigliata: 3(+1/-0) Nm con vite M8  
Peso 2,41 Kg. circa

∅ 280 mm

∅ 11"

**suction / aspirante**

**blowing / soffiante**

**PRODUCT FEATURES**  
**CARATTERISTICHE PRODOTTO**

Static pressure Pressione statica mm H <sub>2</sub> O	suction / aspirante			blowing / soffiante			Static pressure Pressione statica inH <sub>2</sub> O
	Airflow Portata m <sup>3</sup> /h	Current input Corrente assorbita A	Airflow Portata CFM	Airflow Portata m <sup>3</sup> /h	Current input Corrente assorbita A	Airflow Portata CFM	
0	2540	7,0	1499	2390	6,3	1410	0
5	2310	7,5	1363	2180	6,7	1286	0,2
10	2050	8,0	1210	1970	7,3	1162	0,4
15	1750	8,2	1033	1690	7,7	997	0,6
20	1240	8,0	732	1340	7,9	791	0,8
25	910	8,3	537	980	8,1	578	1
30	730	8,6	431	660	8,1	389	1,2
35	520	8,7	307	400	8,3	236	1,4
40	240	9,3	142	140	8,9	83	1,6
45	0	10,2	0	0	9,4	0	1,8

Waterproof motor, IP 68 Motore chiuso, IP 68	✓
Low noise / Bassa rumorosità	✓
Long life / Lunga durata	✓
VLL version* / Versione VLL*	✓
Waterproof connector Connettori a tenuta stagna	✓

\* for OEM applications only.  
\* per applicazioni OEM

✓ = Standard feature  
Caratteristiche standard  
✓ = Available upon request  
Disponibile su richiesta

Test voltage 26 V. D.C. - Tensione di prova 26 V. c.c.