

12V C.C. - D.C.

VA15-AP70/LL-51A
VA15-AP70/LL-51S

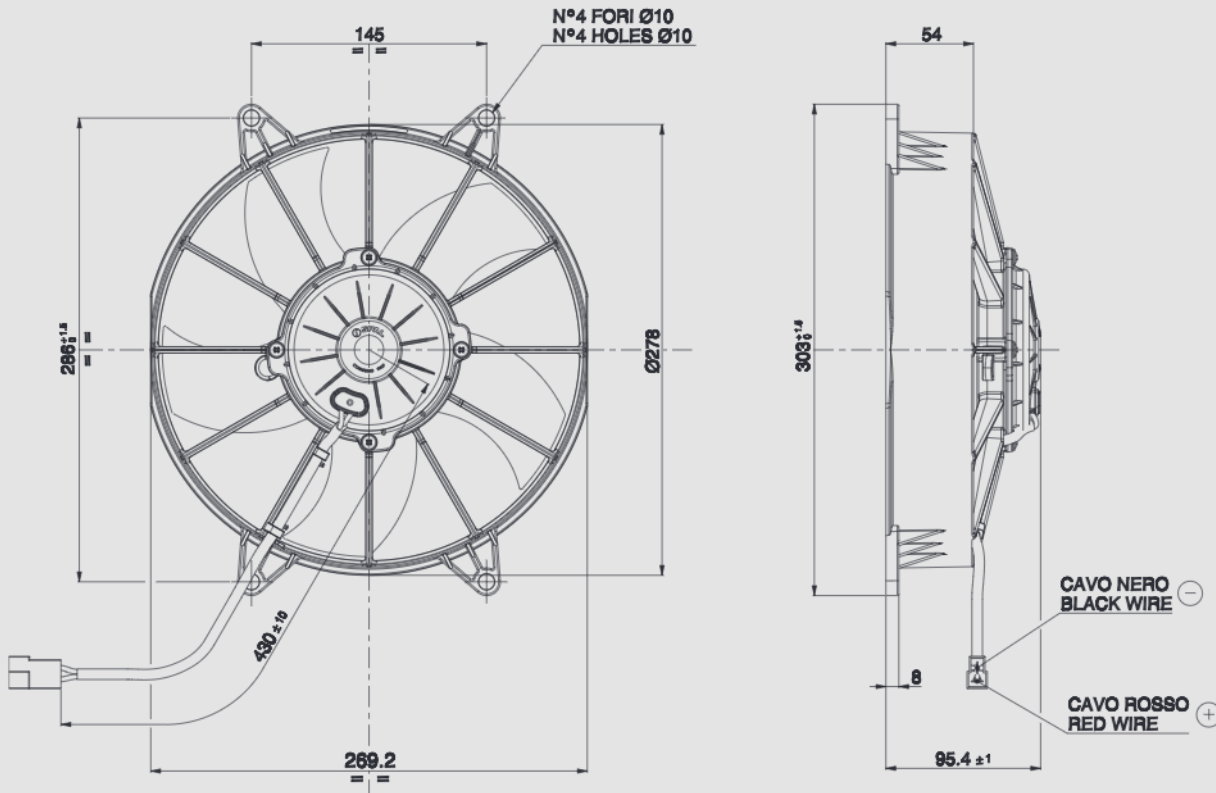

AMP connector Code 180908
AMP terminal Code 42098-2
Suggested mounting torque: 3(+1/-0) Nm with screw M8
Weight 2,24 Kg. approx.

Connettore AMP Cod. 180908
Terminali AMP Cod. 42098-2
Coppia di serraggio consigliata: 3(+1/-0) Nm con vite M8
Peso 2,24 Kg. circa

Ø 255 mm

Ø 10"

suction / aspirante

blowing / soffiante

PRODUCT FEATURES
CARATTERISTICHE PRODOTTO

Static pressure Pressione statica mm H ₂ O	suction / aspirante			blowing / soffiante			Static pressure Pressione statica in H ₂ O
	Airflow Portata m ³ /h	Current input Corrente assorbita A	Airflow Portata CFM	Airflow Portata m ³ /h	Current input Corrente assorbita A	Airflow Portata CFM	
0	1870	10,5	1103	1750	9,6	1033	0
5	1670	11,3	985	1560	10,4	920	0,2
10	1440	12,0	850	1380	11,0	814	0,4
15	1000	11,4	590	1120	11,7	661	0,6
20	720	12,4	425	810	11,9	478	0,8
25	530	12,7	313	540	12,4	319	1
30	390	13,2	230	300	12,8	177	1,2
35	310	13,5	183	210	13,2	124	1,4
40	0	15,4	0	0	14,4	0	1,6

Waterproof motor, IP 68 Motore chiuso, IP 68	✓
Low noise / Bassa rumorosità	✓
Long life / Lunga durata	✓
VLL version* / Versione VLL*	✓
Waterproof connector Connettori a tenuta stagna	✓

* for OEM applications only.
* per applicazioni OEM

✓ = Standard feature
Caratteristiche standard
✓ = Available upon request
Disponibile su richiesta

Test voltage 13 V. d.c. - Tensione di prova 13 V. c.c.

