

12V C.C. - D.C.

VA18-AP71/LL-59A
VA18-AP71/LL-42S

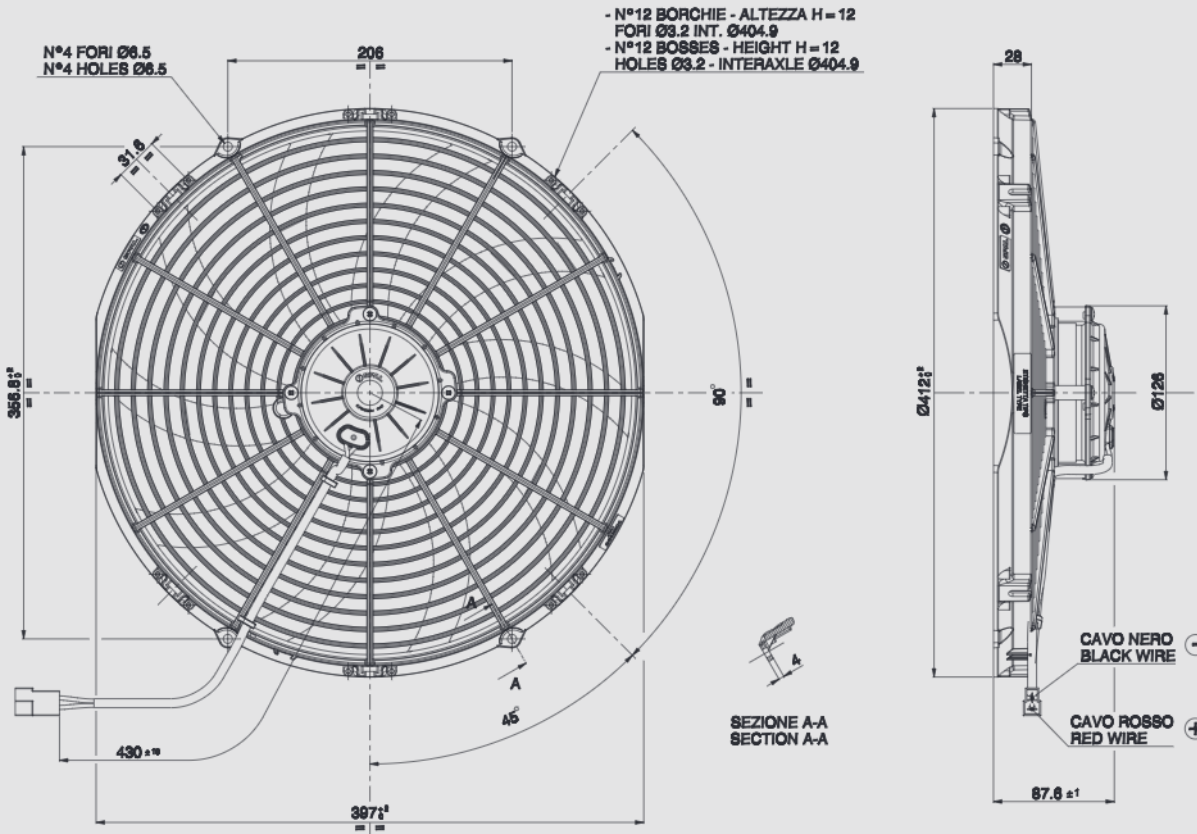

AMP connector Code 180908
AMP terminal Code 42098-2
Suggested mounting torque: 3(+1/-0) Nm with screw M5
Weight 2,57 Kg. approx.

Connettore AMP Cod. 180908
Terminali AMP Cod. 42098-2
Coppia di serraggio consigliata: 3(+1/-0) Nm con vite M5
Peso 2,57 Kg. circa

Ø 385 mm

Ø 16"

suction / aspirante

blowing / soffiante

PRODUCT FEATURES
CARATTERISTICHE PRODOTTO

Static pressure Pressione statica mm H ₂ O	suction / aspirante			blowing / soffiante			Static pressure Pressione statica in H ₂ O
	Airflow Portata m ³ /h	Current input Corrente assorbita A	Airflow Portata CFM	Airflow Portata m ³ /h	Current input Corrente assorbita A	Airflow Portata CFM	
0	3430	19,5	2024	3320	21,5	1959	0
2,5	3300	19,9	1947	3030	21,6	1788	0,1
5	3090	20,5	1823	2770	21,8	1634	0,2
7,5	2840	20,2	1676	2500	21,8	1475	0,3
10	2510	21,0	1481	2090	21,5	1233	0,4
12,5	2170	20,3	1280	1700	20,8	1003	0,5
15	1600	19,3	944	1200	20,2	708	0,6
17,5	1030	18,0	608	530	20,5	313	0,7
20	660	17,7	389	0	20,6	0	0,8
25	0	18,0	0				1

Waterproof motor, IP 68 Motore chiuso, IP 68	✓
Low noise / Bassa rumorosità	✓
Long life / Lunga durata	✓
VLL version* / Versione VLL*	✓
Waterproof connector Connettori a tenuta stagna	✓
Accessories: all the fixing kits Accessori: tutti i kit di fissaggio	✓

* for OEM applications only.
* per applicazioni OEM

✓ = Standard feature
Caratteristiche standard
✓ = Available upon request
Disponibile su richiesta

Test voltage 13 V. d.c. - Tensione di prova 13 V. c.c.