

12V C.C. - D.C.

VA18-AP51/C-41A
VA18-AP51/C-41S

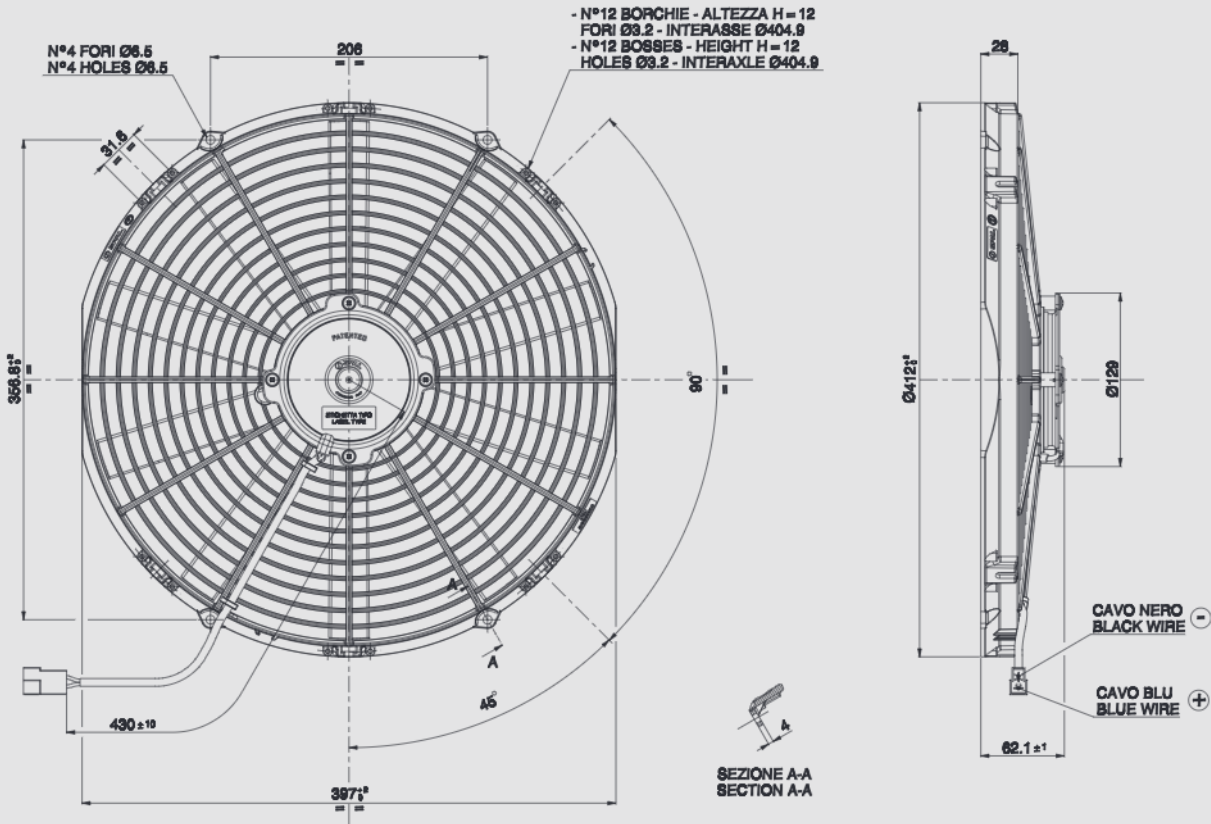

AMP connector Code 180908
AMP terminal Code 42098-2
Suggested mounting torque: 3(+1/-0) Nm with screw M5
Weight 1,75 Kg. approx.

Connettore AMP Cod. 180908
Terminali AMP Cod. 42098-2
Coppia di serraggio consigliata: 3(+1/-0) Nm con vite M5
Peso 1,75 Kg. circa

Ø 385 mm

Ø 16"

suction / aspirante

blowing / soffiante

PRODUCT FEATURES
CARATTERISTICHE PRODOTTO

Static pressure Pressione statica mm H ₂ O	suction / aspirante			blowing / soffiante			Static pressure Pressione statica in H ₂ O
	Airflow Portata m ³ /h	Current input Corrente assorbita A	Airflow Portata CFM	Airflow Portata m ³ /h	Current input Corrente assorbita A	Airflow Portata CFM	
0	2490	10,7	1469	2550	10,5	1505	0
2,5	2280	11,6	1345	2360	11,2	1392	0,1
5	2050	12,1	1210	2180	11,6	1286	0,2
7,5	1960	12,5	1156	2010	11,8	1186	0,3
10	1660	12,7	979	1640	12,2	968	0,4
12,5	1270	12,1	749	1310	12,3	773	0,5
15	970	11,6	572	1090	11,8	643	0,6
17,5	810	11,8	478	750	11,7	443	0,7
20	470	11,6	277	550	11,2	325	0,8
25	0	11,6	0	0	11,1	0	1

Waterproof motor, IP 68
Motore chiuso, IP 68



Long life / Lunga durata



LL and VLL version*
Versione LL e VLL*



Waterproof connector
Connettori a tenuta stagna



Accessories: all the fixing kits
Accessori: tutti i kit di fissaggio



* for OEM applications only.
* per applicazioni OEM

✓ = Standard feature
Caratteristiche standard

✓ = Available upon request
Disponibile su richiesta

Test voltage 13 V. d.c. - Tensione di prova 13 V. c.c.