

# SERVE & STORE PREP CART

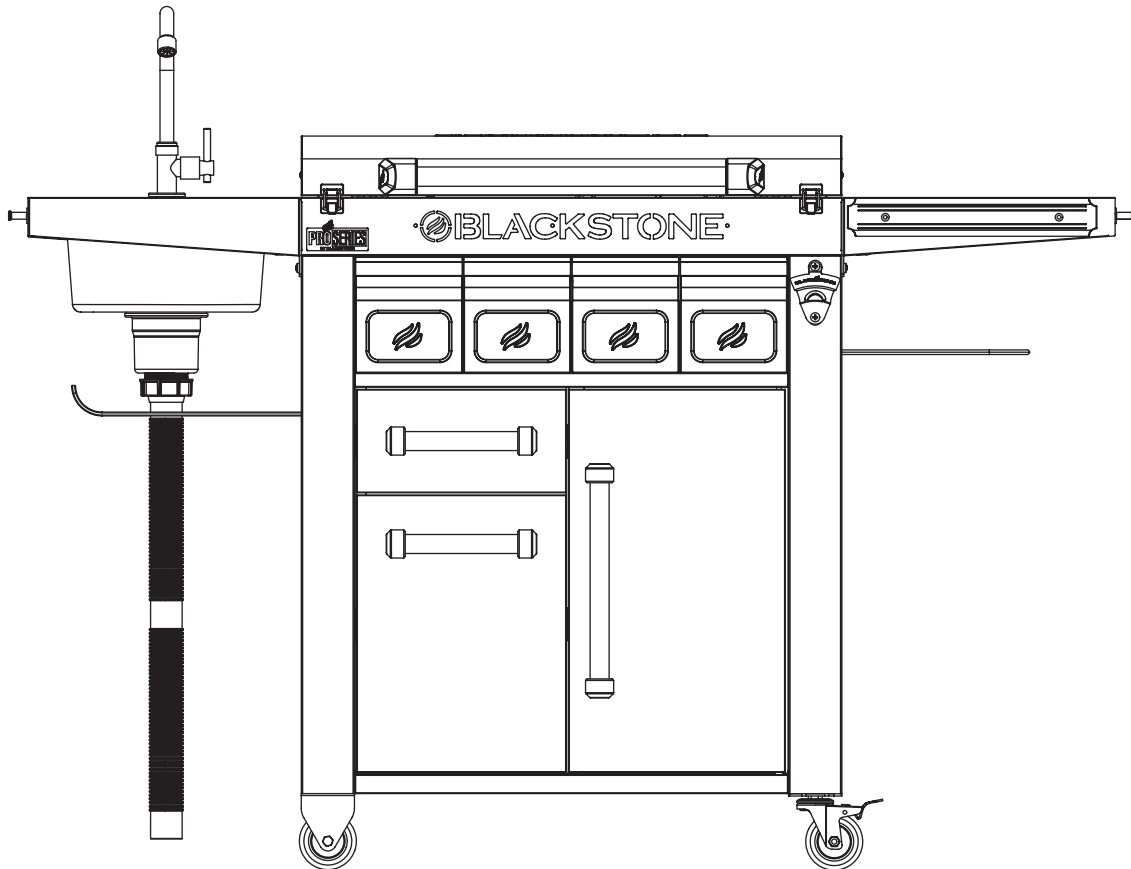



# TABLE OF CONTENTS

*It is the consumer's responsibility to see that the unit is properly assembled, installed, and maintained. Failure to follow the instructions in this manual could result in bodily injury and/or property damage.*



## CONTENTS

01. WARRANTY.....01

02. ASSEMBLY GUIDE .....02

### SAFETY ALERT KEY

Read and follow all the notices throughout the manual.

<b> DANGER</b>
Indicates an imminently hazardous situation which, if not avoided, may result in death or serious injury.
<b> WARNING</b>
Indicates the possibility of serious bodily injury if the instructions are not followed.
<b> CAUTION</b>
Indicates a potentially hazardous situation which, if not avoided, may result in minor or moderate injury.



# NORTH ATLANTIC IMPORTS LLC 1-YEAR WARRANTY

North Atlantic Imports, the manufacturer, will warranty for one year from purchase all parts, workmanship, and finishes. It will be the manufacturer's option as to whether to repair or replace any of the above items. All warranties are limited to the original purchaser only. This warranty does not cover any liability on the part of North Atlantic Imports, its agents or employees, for any indirect or consequential damages for breach of warranty. The purchaser must follow the manufacturer's usage instructions.

Under no circumstances is the manufacturer responsible for damages from the failure to operate the cooking station properly. It is the responsibility of the purchaser to establish the warranty period by verifying the original purchase date with original sales receipt.

*For more detailed explanation of the warranty, read below:*

North Atlantic Imports LLC warrants to the owner that the product covered by this agreement is free from defects in material and workmanship under normal use and service for which it was intended if, but only if, it has been operated in accordance with North Atlantic Imports LLC instructions exclusively for domestic use, and not for private or public club, institutional or commercial purposes.

North Atlantic Imports LLC's obligation under this warranty is limited to replacing or repairing, free of charge, any part or parts that may prove, to the satisfaction of North Atlantic Imports LLC, to be defective under normal home use and service within the following stated periods of time from the date of purchase; for one year from purchase, all parts, finish, and workmanship. Should any failure to conform to this warranty become apparent during applicable warranty periods stated above, the original purchaser must notify North Atlantic Imports LLC of breach of warranty within the applicable warranty period.

North Atlantic Imports LLC shall upon notice and compliance by the original purchaser with such instructions, correct such nonconformity by repair or replacement of the defective part or parts.

Correction in the manner provided above shall constitute a fulfillment of all obligations of North Atlantic Imports LLC with respect to the quality of the product.

North Atlantic Imports LLC does not warrant this equipment to meet the requirement of any safety code of any state, municipality or other jurisdiction, and the original purchaser assumes all risk and liability whatsoever resulting from the use thereof, whether used in accordance with North Atlantic Imports LLC instructions or otherwise.

This warranty does not cover and is intended to exclude any liability on the part of North Atlantic its agents, servants or employees whether under this warranty or implied by law for any indirect or consequential damages for breach on any warranty. The purchaser must

establish all applicable warranty periods pursuant to this warranty by verifying the original purchase date by producing the dated sales receipt. This warranty shall not apply to this product or any other part thereof which has been subject to accident, negligence, alteration, abuse, or misuse or which has been repaired or altered without North Atlantic written consent, outside of North Atlantic Imports LLC factory. The full manufacturer warranty is not valid for griddles purchased from unlicensed, third-party resellers, purchased at a discount due to missing or damaged parts, or purchased as a floor model; at the discretion of North Atlantic Imports.











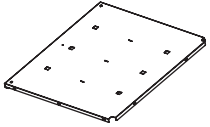

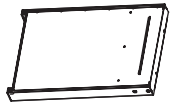
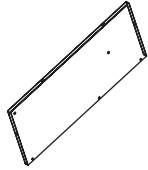
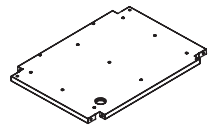

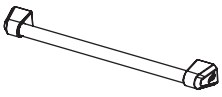
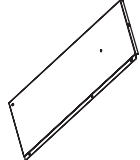

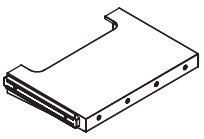
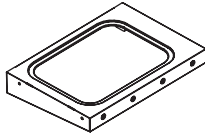
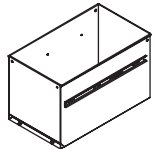

North Atlantic Imports LLC makes no warranty whatsoever in respect to accessories or parts not supplied with it. This warranty shall apply only within the boundaries of the United States of America. This warranty gives the original purchaser specific rights, and the original purchaser may also have other rights, which vary from state to state.

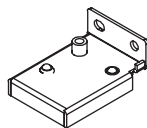
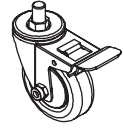
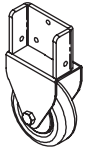
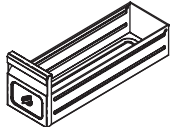
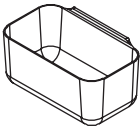

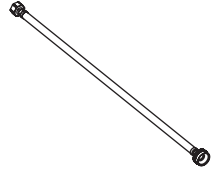
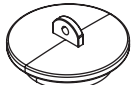
# ASSEMBLY GUIDE











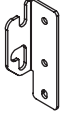

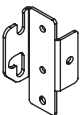

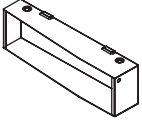

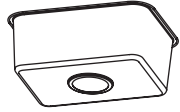

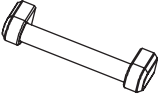
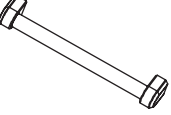
## ILLUSTRATED PARTS LIST

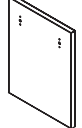
ENGLISH

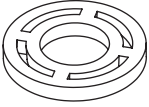
<p><b>№ 1 BOX</b></p>	<p><b>1</b> Top drawer panel (1 piece)</p> 	<p><b>2</b> Left leg assembly (1 piece)</p> 	<p><b>3</b> Right leg assembly (1 piece)</p> 	<p><b>№ 6 BOX</b> <i>Inside № 1 Box</i></p>	<p><b>4</b> Left rear panel (1 piece)</p> 
<p><b>№ 2 BOX</b></p>	<p><b>5</b> Bottom panel (1 piece)</p> 	<p><b>6</b> Table top (1 piece)</p> 	<p><b>7</b> Lid handle (1 piece)</p> 	<p><b>8</b> Right rear panel (1 piece)</p> 	<p><b>9</b> Cart door (1 piece)</p> 
<p><b>10</b> Garbage bag holder (1 piece)</p> 	<p><b>11</b> Center drawer panel (1 piece)</p> 	<p><b>№ 7 BOX</b> <i>Inside № 2 Box</i></p>	<p><b>12</b> Right side shelf (1 piece)</p> 	<p><b>13</b> Left side shelf (1 piece)</p> 	<p><b>№ 8 BOX</b> <i>Inside № 7 Box</i></p>
<p><b>№ 3 BOX</b></p>	<p><b>14</b> Bottom drawer (1 piece)</p> 	<p><b>15</b> Paper towel holder (1 piece)</p> 	<p><b>16</b> Paper towel holder bracket (1 piece)</p> 	<p><b>17</b> Caster wheels (2 pieces)</p> 	<p><b>18</b> Fixed wheels (2 pieces)</p> 
<p><b>19</b> Small drawers (2 pieces)</p> 	<p><b>20</b> Seasoning boxes (4 pieces)</p> 	<p><b>21</b> Seasoning box lids (4 pieces)</p> 	<p><b>22</b> Faucet hose (1 piece)</p> 	<p><b>23</b> Bottom drawer plug (1 piece)</p> 	<p><b>24</b> Inner gasket (1 piece)</p> 
<p><b>25</b> Outer gasket (1 piece)</p> 	<p><b>26</b> Filter cover (1 piece)</p> 	<p><b>27</b> Filter (1 piece)</p> 	<p><b>28</b> Inner water output (1 piece)</p> 	<p><b>29</b> Outer water output (1 piece)</p> 	

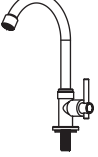

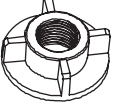
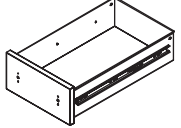
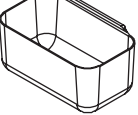

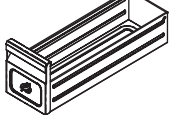
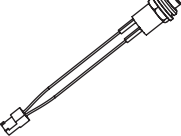
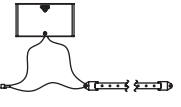
<p><b>№ 9 BOX</b> <i>Inside № 3 Box</i></p>	<p><b>30</b> Left front side shelf bracket (1 piece)</p> 	<p><b>31</b> Right front side shelf bracket (1 piece)</p> 	<p><b>32</b> Left rear side shelf bracket (1 piece)</p> 	<p><b>33</b> Right rear side shelf bracket (1 piece)</p> 	<p><b>34</b> Bottle opener (1 piece)</p> 
<p><b>35</b> Spacing boards (3 pieces)</p> 	<p><b>36</b> Faucet support panel (1 piece)</p> 	<p><b>№ 4 BOX</b></p>	<p><b>37</b> Plastic nut (1 piece)</p> 	<p><b>38</b> Sink (1 piece)</p> 	<p><b>39</b> Seasoning box holder (1 piece)</p> 
<p><b>№ 10 BOX</b> <i>Inside № 4 Box</i></p>	<p><b>40</b> Drawer handles (2 pieces)</p> 	<p><b>41</b> Door handle (1 piece)</p> 	<p><b>42</b> Faucet base (1 piece)</p> 	<p><b>43</b> Bottom drawer face plate (1 piece)</p> 	<p><b>44</b> Plastic water tube (1 piece)</p> 
<p><b>45</b> Female silicone ring (1 piece)</p> 	<p><b>46</b> Male silicone ring (1 piece)</p> 	<p><b>47</b> Faucet (1 piece)</p> 	<p><b>48</b> Metal hooks (4 pieces)</p> 	<p><b>49</b> Faucet nut (1 piece)</p> 	
<p><b>№ 5 BOX</b></p>	<p><b>50</b> Top drawer (1 piece)</p> 	<p><b>51</b> Seasoning boxes (4 pieces)</p> 	<p><b>52</b> Seasoning box lids (4 pieces)</p> 	<p><b>53</b> Small drawers (2 pieces)</p> 	
<p><b>№ 11 BOX</b></p>	<p><b>54</b> LED button assembly (1 piece)</p> 	<p><b>55</b> LED strip and battery pack (1 piece)</p> 			



- 56** Hardware pack (1 piece)
- a.** M6x12 screws (15 pieces) (17 pieces) (15 pieces)
- b.** M6x20 step bolts (12 pieces)
- c.** Shelf pegs (8 pieces)
- d.** Shelf peg washers (8 pieces)
- e.** Washers (2 pieces)
- f.** M4 Flange nuts (2 pieces)
- g.** Tapping screws (6 pieces)
- h.** M4x10 screws (17 pieces) (16 pieces)

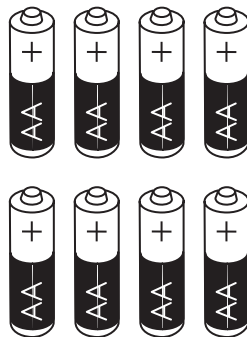
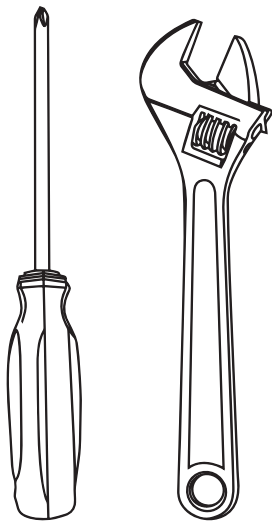
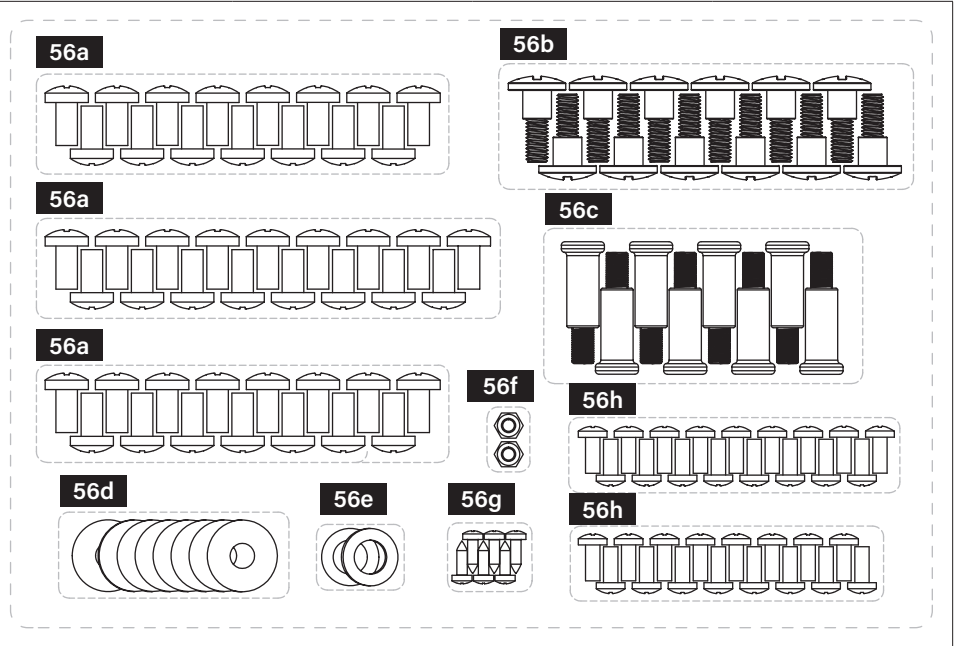

**TOOLS NEEDED:** Phillips head screwdriver & Adjustable wrench

**NOT INCLUDED:** Eight (8) AA Batteries



## ASSEMBLY INSTRUCTIONS

*Please read all instructions thoroughly before proceeding. Ensure that all plastic packing material and any transit protection is removed before assembling.*

Find a large, clean area to assemble your unit. Please refer to the parts list and assembly diagrams as necessary.

**STEP 01** Remove the joint leg assembly from the packaging. Loosen the four (4) screws and separate the left and right leg assemblies.

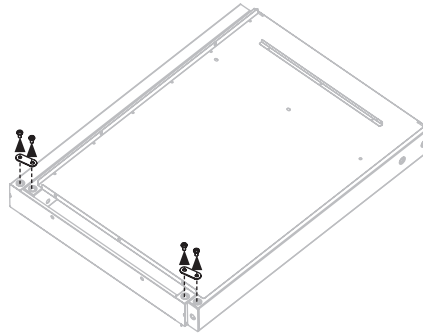

**STEP 02** Use three (3) M4x10 (h.) screws to install the left leg assembly to the bottom panel.

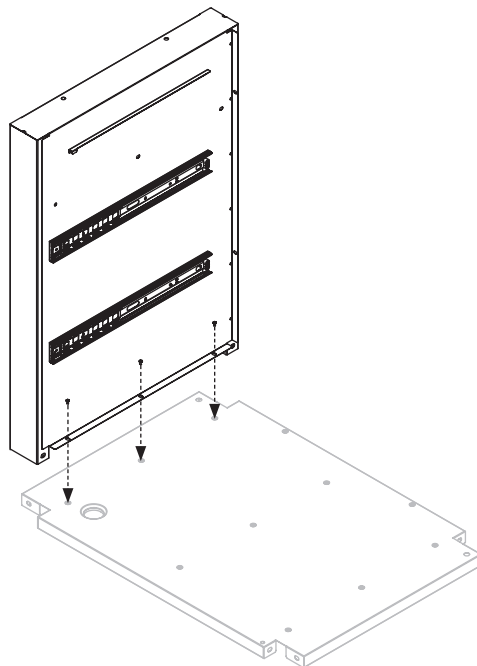

### ⚠ WARNING

The manufacturer has made every effort to eliminate any sharp edges. However, you should handle all components with care to avoid accidental injury.

Some parts may contain sharp edges, especially as noted in these instructions. Wear protective gloves if necessary.

### ⚠ WARNING

The use of alcohol, prescription or non-prescription drugs may impair the consumer's ability to properly assemble or safely operate the appliance.

### ⚠ CAUTION

Two people are recommended for the assembly of this product.



**STEP 03** Use three (3) M4x10 screws (**h.**) to install the right leg assembly to the bottom panel.

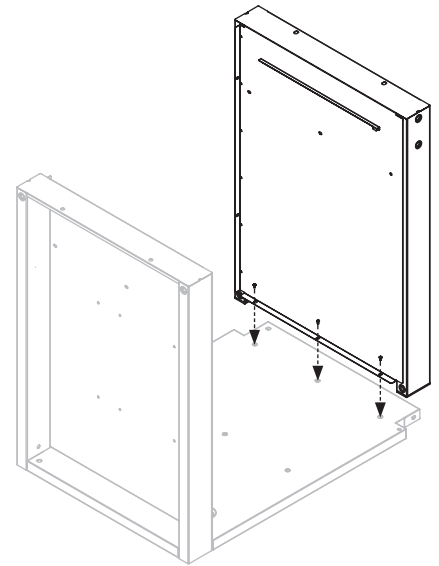

**STEP 04** **With the help of another person,** set the cart on its back. Use four (4) M6x12 screws (**a.**) to attach the two (2) fixed wheels to the left leg assembly. Use four (4) M6x12 screws (**a.**) to secure the right leg assembly to the bottom panel, then insert the caster wheels into the right leg assembly.

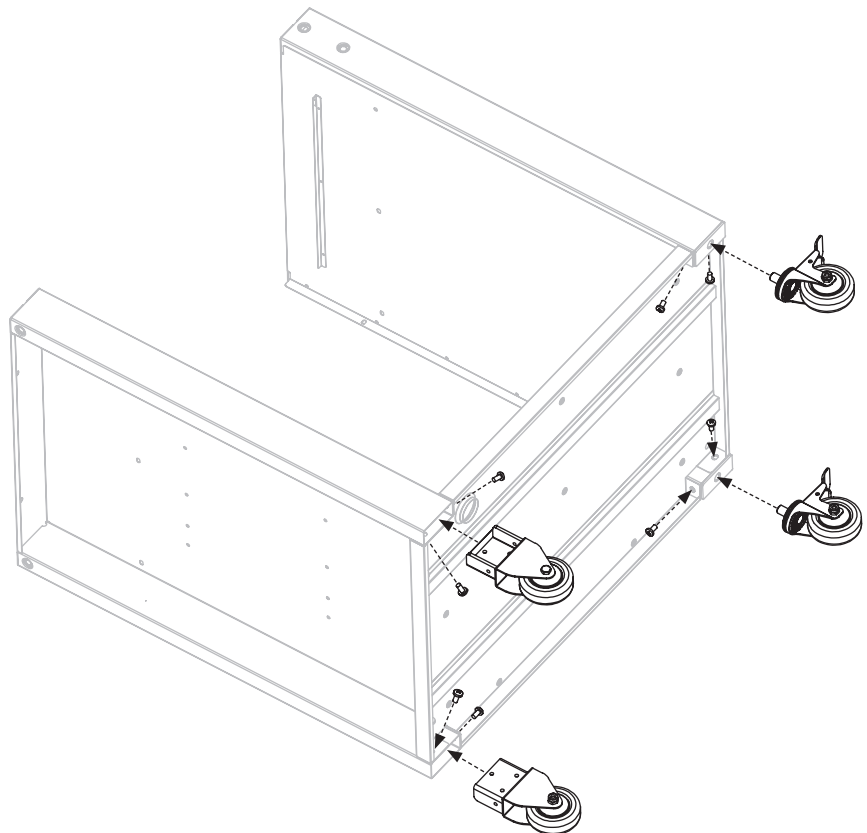



**STEP 05** With the help of another person, set the cart on its feet and use two (2) M6x12 (**a.**) screws to secure the fixed wheels.

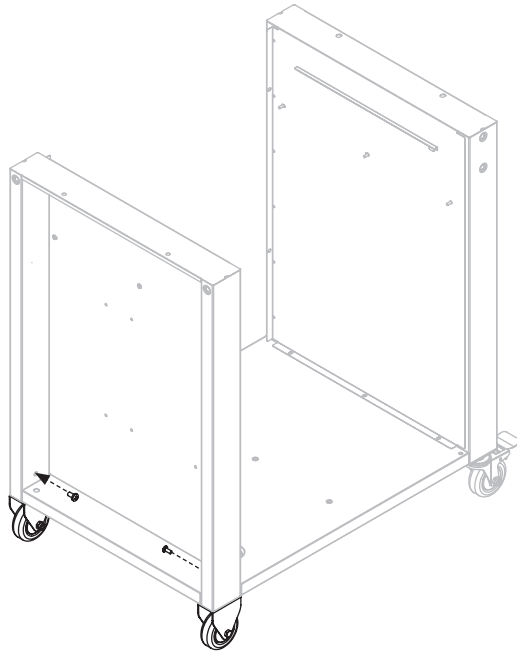

**STEP 06** Use three (3) M4x10 (**h.**) screws to attach the right rear panel to right leg assembly and bottom panel.

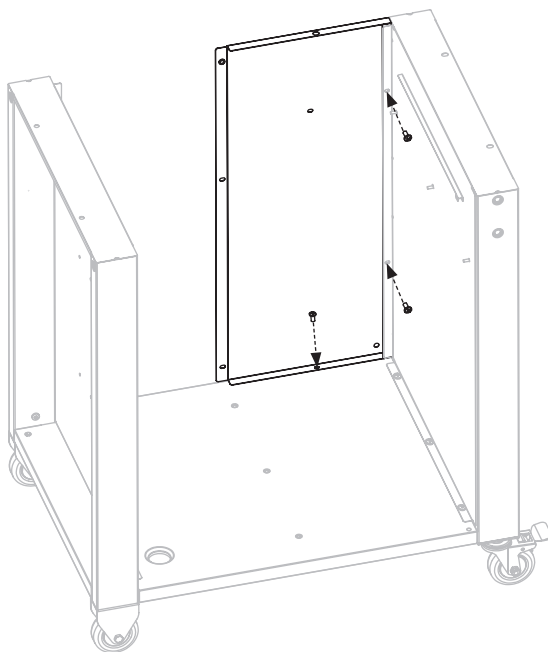



**STEP 07** Use three (3) M4x10 screws (**h.**) to attach the left rear panel to the left leg assembly and bottom panel. Use one (1) M4x10 screw (**h.**) to secure the left rear panel to the right rear panel.

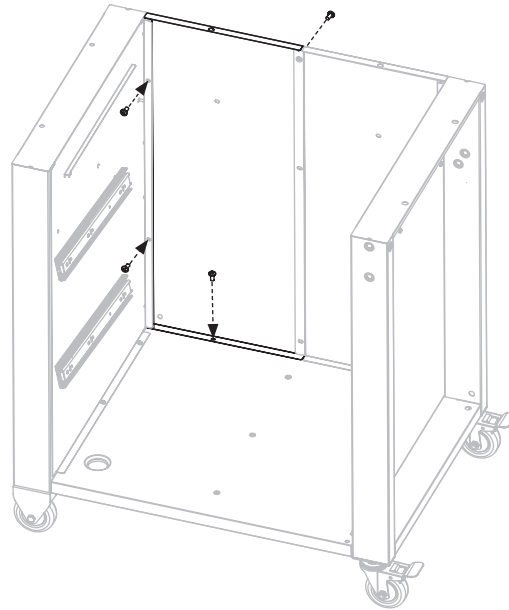

**STEP 08** **With the help of another person,** place the table top on the cart. Use four (4) M6x12 screws (**a.**) to secure the table to the left and right leg assemblies (two (2) per side). Use two (2) M6x12 screws (**a.**) to secure the table to the back panels.

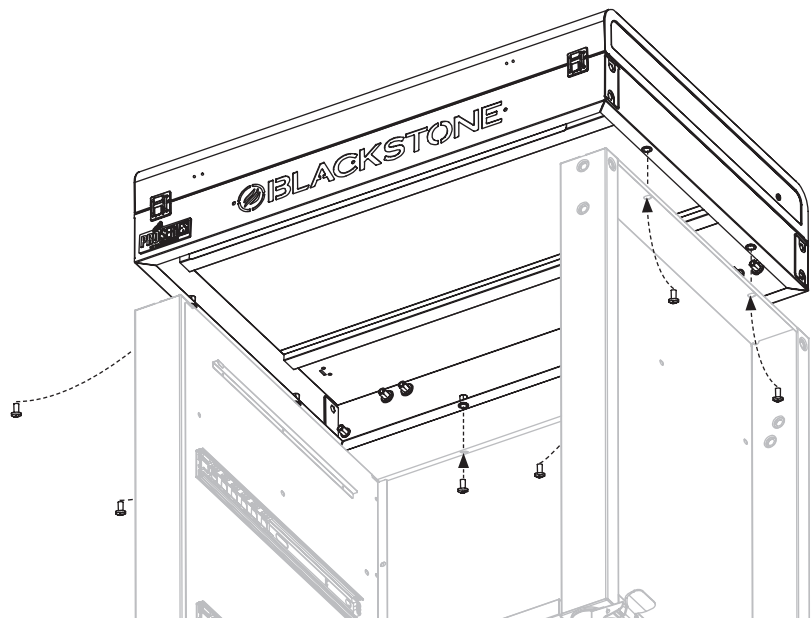



**STEP 09** Use three (3) M4x10 screws (**h.**) to attach the center drawer panel to the bottom panel.

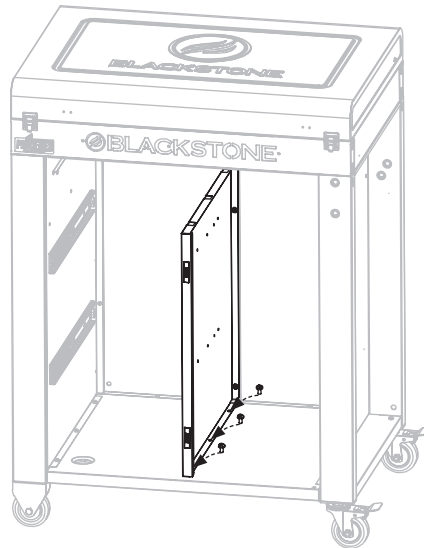

Use two (2) M4x10 screws (**h.**) to secure the middle drawer panel to the rear panels.

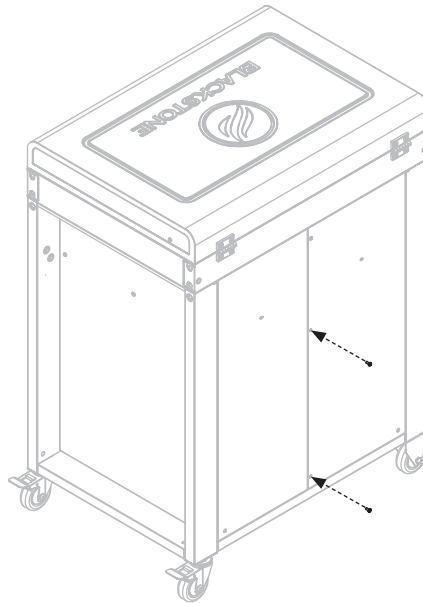

**STEP 10** Use six (6) M3 tapping screws (**g.**) to attach the three (3) spacing boards to the top drawer panel.

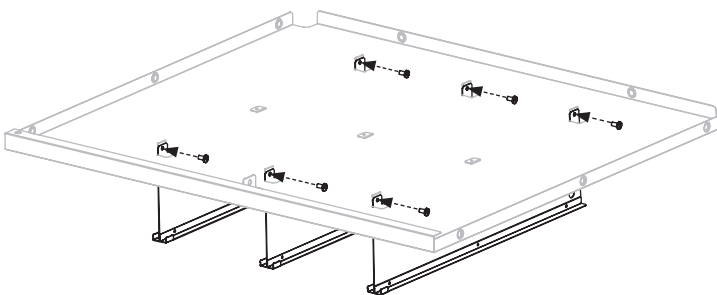



**STEP 11** Align the center spacing board so that it inserts into the top slots of the middle drawer panel. Use six (6) M4x10 screws (**h.**) to attach the top drawer panel to the leg assemblies, and one (1) M4x10 screw (**h.**) to secure the top drawer panel to the middle drawer panel.

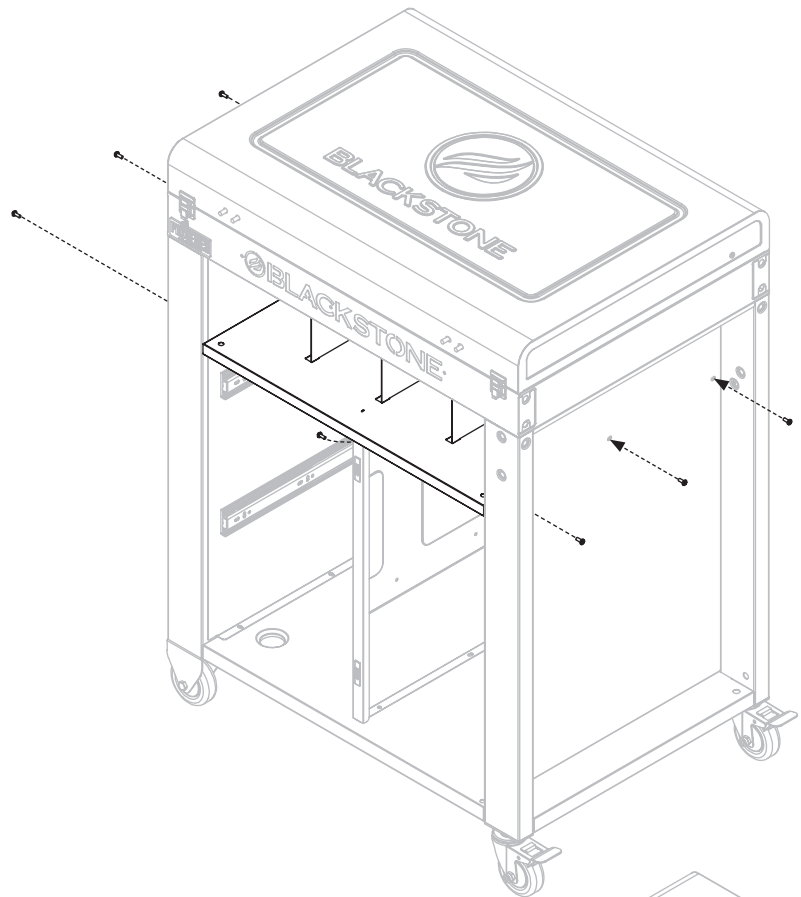

Use two (2) M4x10 screws (**h.**) to secure the top drawer panel to the rear panels.

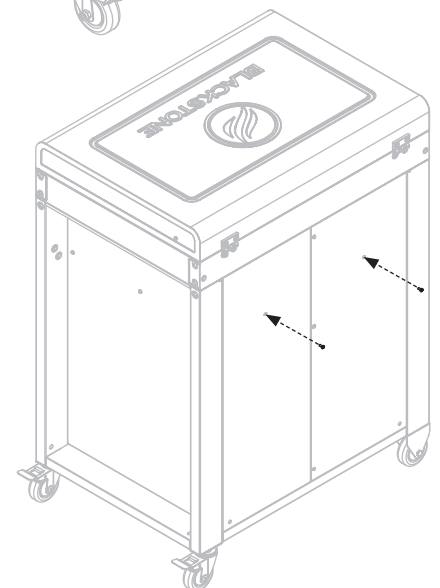





**STEP 12** Use two (2) M6x12 screws (**a.**) to attach one (1) door handle to the right cart door.

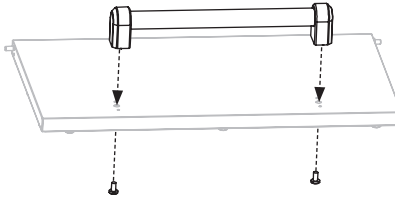

**STEP 13** Attach the right cart door to the cart by first **1** inserting the lower door hinge pin, then **2** inserting the upper door hinge pin.

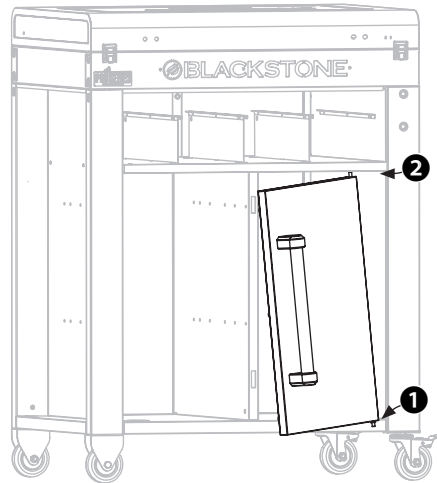

**STEP 14** Use two (2) M6x12 screws (**a.**) to attach one (1) drawer handle to the lower drawer front plate.

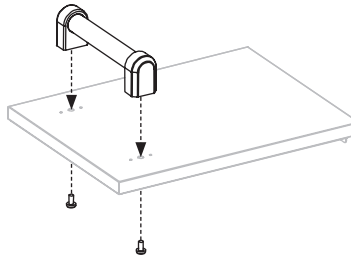

Use four (4) M4x10 screws (**h.**) to attach the lower drawer front plate to the lower drawer.

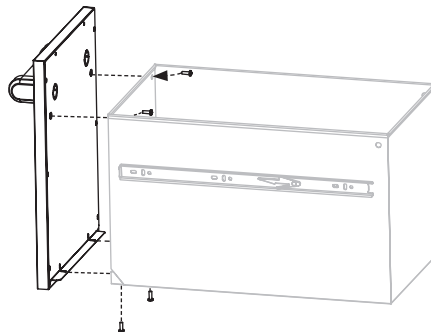



**STEP 15** Insert the plug in the pre-cut hole of the lower drawer.

Pull out the lower drawer rail.

Align the drawer rail between the lower drawer and the cart, and slide the lower drawer into place.

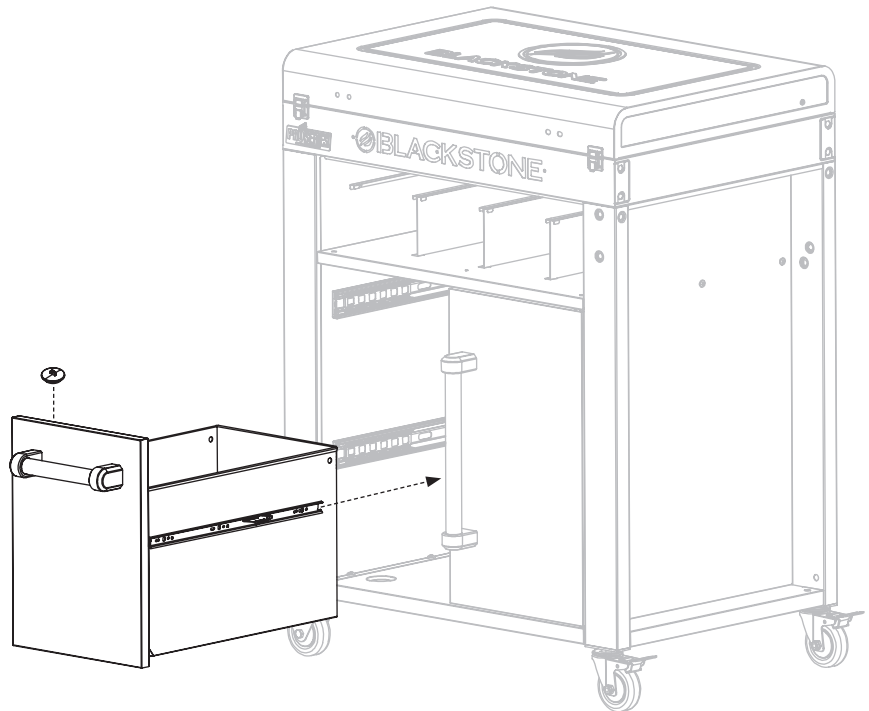

**STEP 16** Use two (2) M6x12 screws (a.) to attach one (1) drawer handle to the upper drawer.

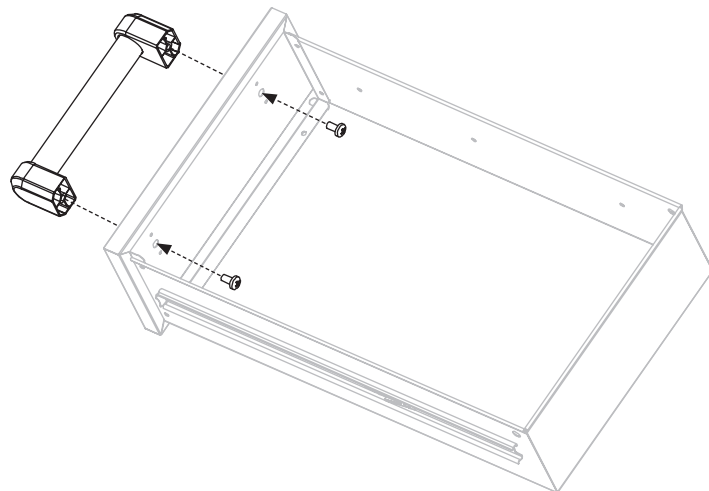

**STEP 17** Pull out the upper drawer rail.

Align the drawer rail between the upper drawer and the cart, and slide the upper drawer into place.

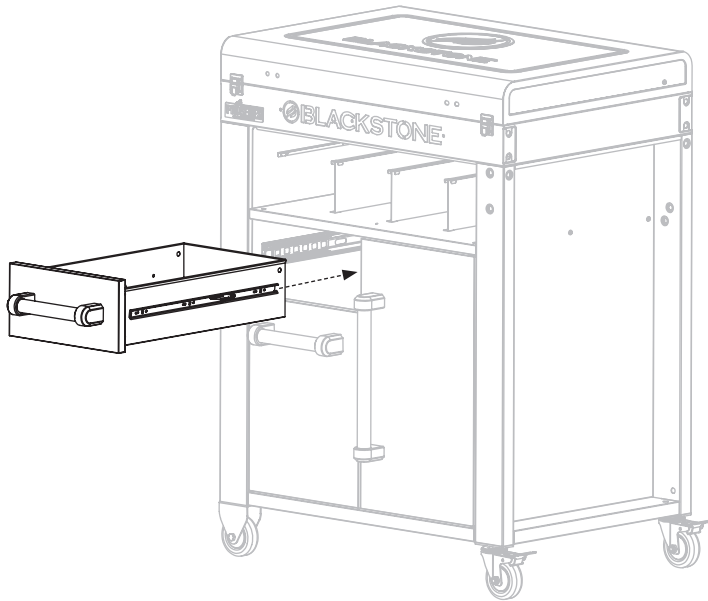
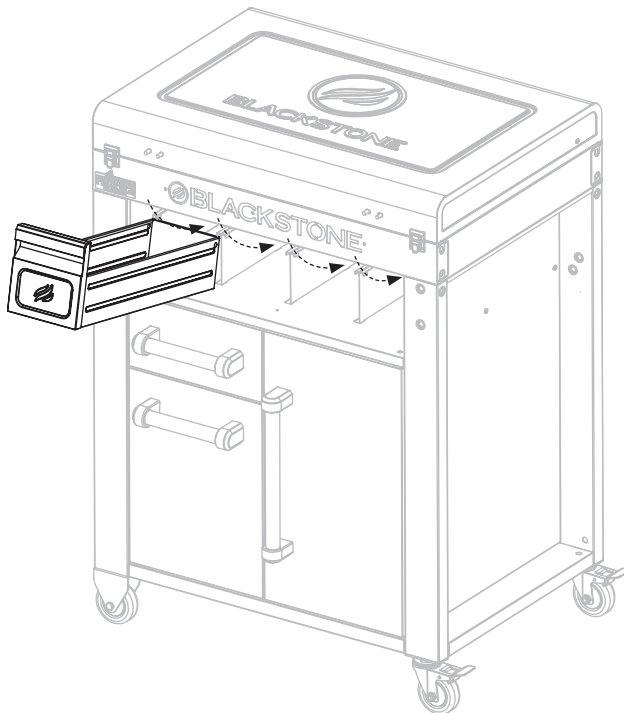
**STEP 18** Tilt the four (4) small drawers and slide them into place.



ENGLISH

**STEP 19** Use two (2) M6x12 screws (**a.**) to attach the paper towel bracket to the left side of the cart.

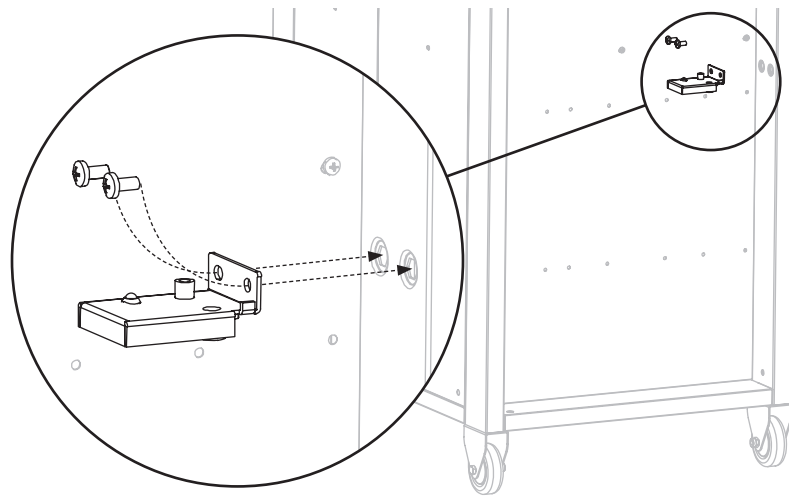

**STEP 20** Use one (1) M6x12 screw (**a.**) and two (2) washers (**e.**) to attach the paper towel holder onto the paper towel bracket.

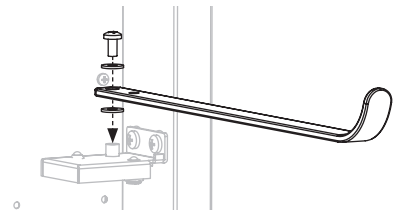

**STEP 21** Screw two (2) M6x20 step bolts (**b.**) into the lower holes of the right leg assembly.

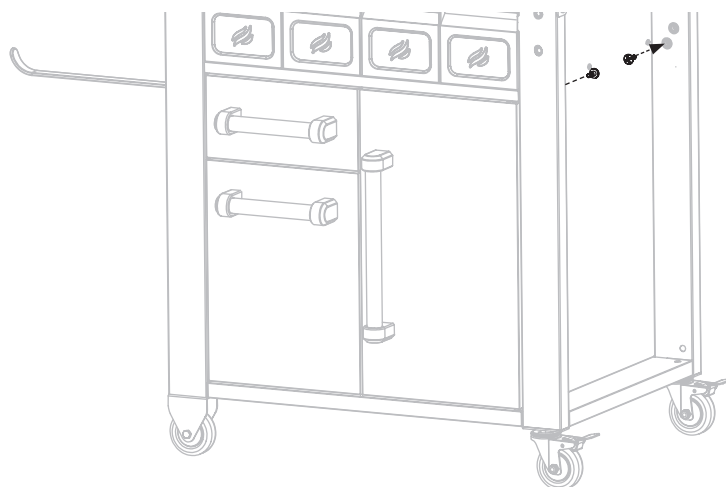



**STEP 22** Use two (2) M6x20 step bolts (**b.**) to attach the garbage bag holder to the right leg assembly.

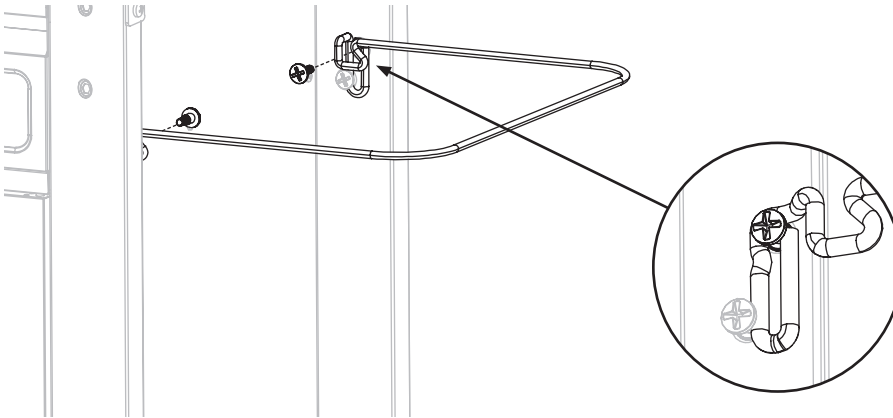

**STEP 23** Use seven (7) M6x12 screws (**a.**) to attach two (2) right side shelf brackets to the right side of the cart.

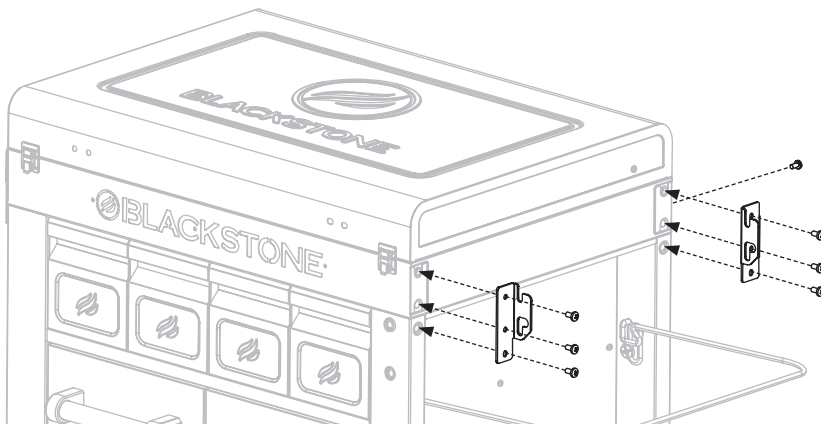

**STEP 24** Use seven (7) M6x12 screws (**a.**) to attach two (2) left side shelf brackets to the left side of the cart.

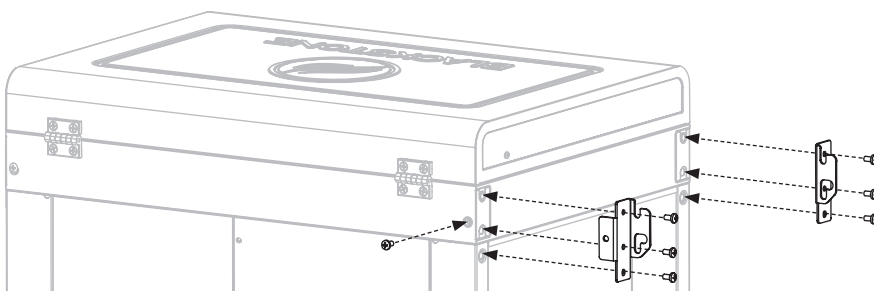

**CAUTION**

Maximum weight on side shelf is 10 lbs.

ENGLISH

**STEP 25** Thread two (2) M6x20 step bolts (**b.**) into the upper holes of the right side shelf.

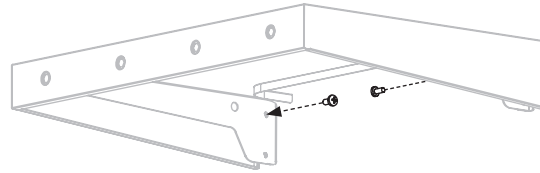

**STEP 26** Use two (2) M6x12 screws (**a.**) to attach the faucet support panel to the left side shelf.

Thread two (2) M6x20 step bolts (**b.**) into the upper holes of the left side shelf.

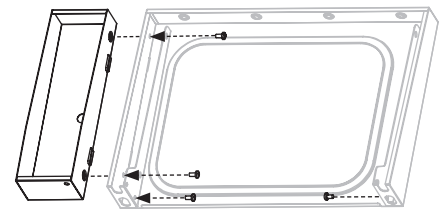

**STEP 27** Hook the right side shelf bolts onto the side shelf brackets. Thread two (2) M6x20 step bolts (**b.**) into the lower holes of the brackets to secure the right side shelf to the shelf brackets.

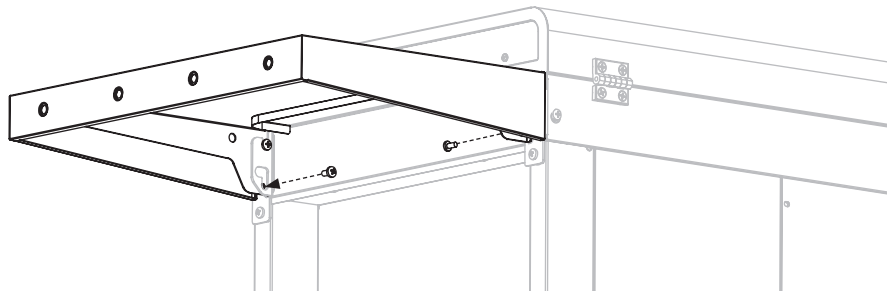

**STEP 28** Hook the left side shelf bolts onto the side shelf brackets. Thread two (2) M6x20 step bolts (**b.**) into the lower holes of the brackets to secure the left side shelf to the shelf brackets.

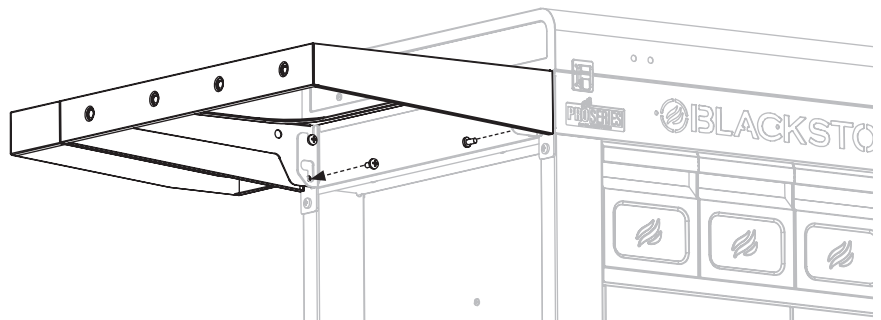



**STEP 29** Attach the four (4) side shelf pegs (**c.**) and four (4) peg washers (**d.**) to both side shelves by screwing them into the precut holes.



**STEP 30** Install the inner gasket, inner water output, filter and filter cover into the bottom of the sink.

Set the outer gasket against the bottom of the sink and screw the outer water output into the inner water output.

Use the plastic nut to attach the plastic water tube to the outer water output.

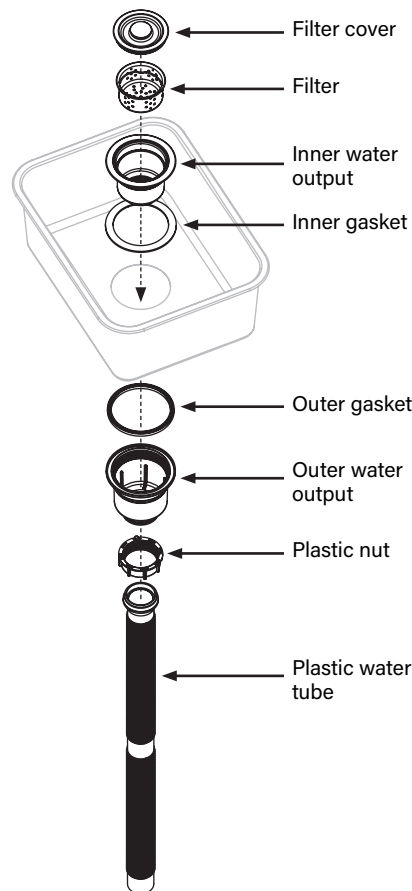



**STEP 31** Place the sink into the left side shelf.  
(Direct the plastic water tube into a bucket, or other receptacle.)

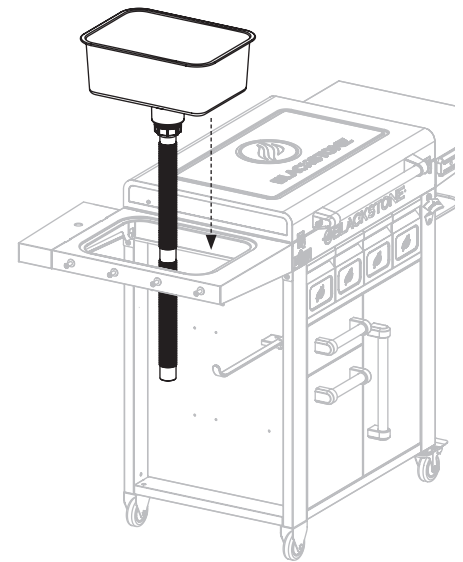

**STEP 32** Use two (2) M6x12 screws (a.) to attach the bottle opener to the front of the right leg assembly.

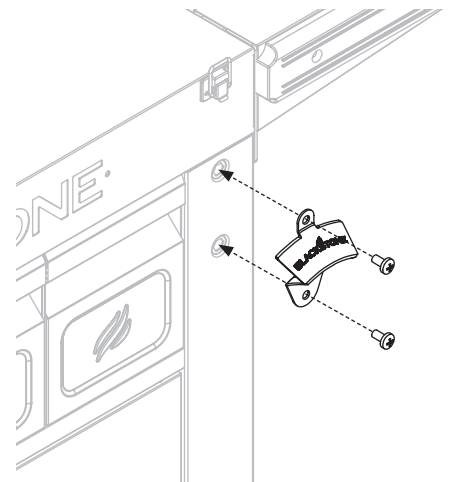

**STEP 33** Attach the faucet base and the female silicone ring onto the bottom of the faucet.

Insert the faucet into the precut hole of the faucet support panel, then attach the male silicone ring and the faucet nut to the end of the faucet.

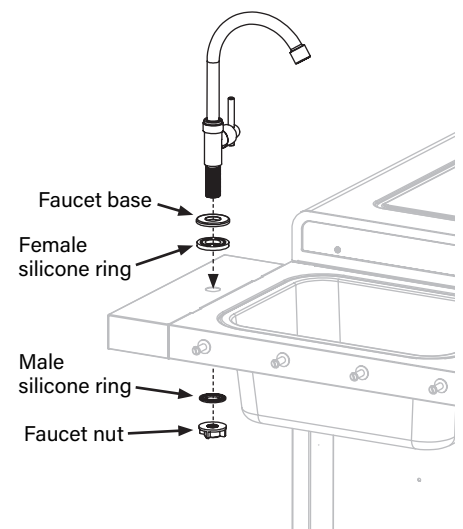





**STEP 34** Attach the faucet hose to the faucet. A standard garden hose (not included) can now be connected to the faucet hose.

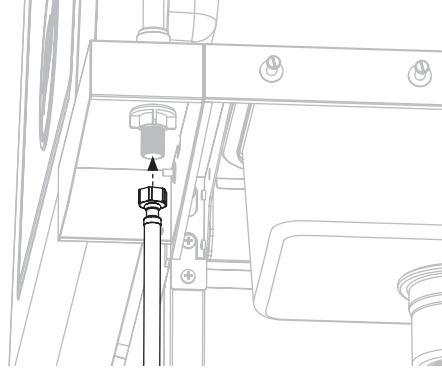

**⚠ WARNING**

- Do not mix old and new batteries.
- Do not mix alkaline, standard (carbon-zinc) or rechargeable (ni-cad, ni-mh, etc.) batteries.

**STEP 35** From the underside of the lid, remove the six (6) M4x10 screws from the LED bracket and from the battery pack cover.

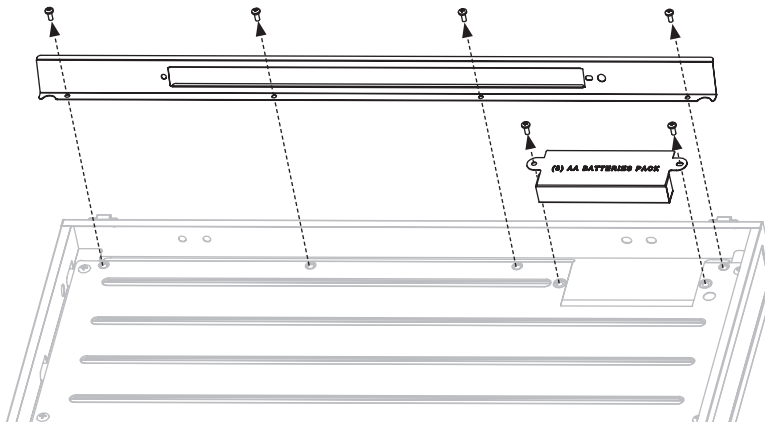

**STEP 36** Insert eight (8) AA batteries (not included) into the battery pack.

Attach the battery pack to the battery pack cover.

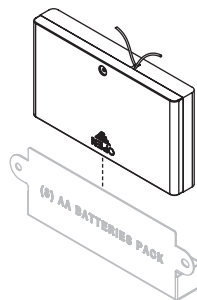

**STEP 37** Use two (2) M4x10 screws (h.) and two (2) M4 nuts (f.) to attach the LED strip to the LED bracket.

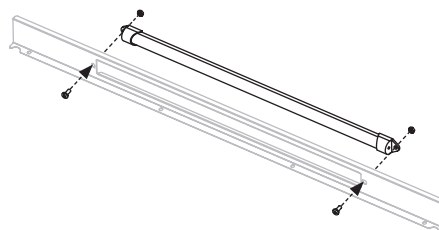



**STEP 38** Thread the LED button assembly through the hole in the underside of the lid, and connect it to the battery pack terminal.

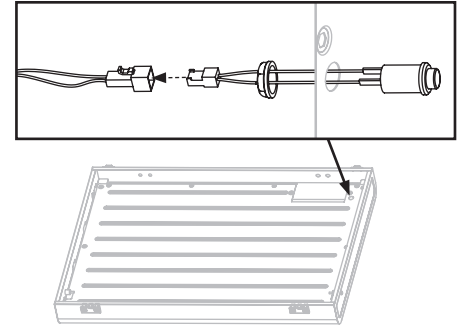

**STEP 39** Use four (4) M6x12 (a.) screws to attach the lid handle to the lid. Re-attach the battery pack cover with the battery pack underneath. Re-attach the LED bracket.

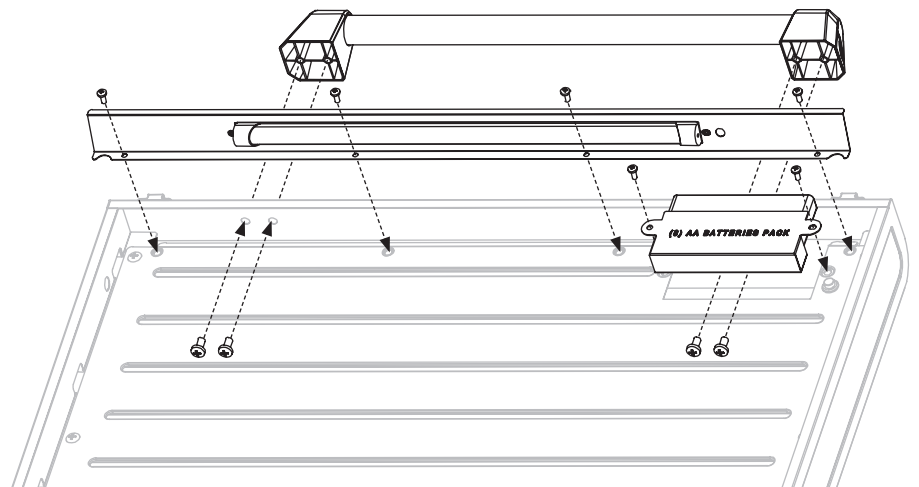

**STEP 40** Hang the eight (8) seasoning boxes and the four (4) metal hooks on the slots inside the lid.

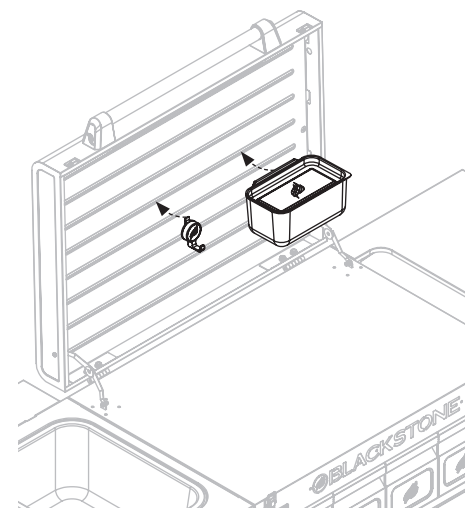



**STEP 41** Enjoy cooking outdoors with your Blackstone Store & Serve Prep Cart!

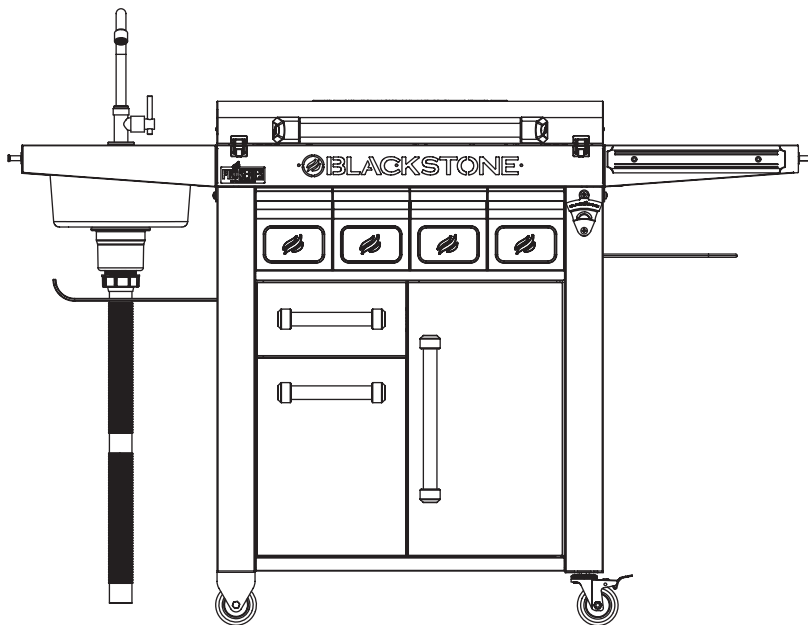

When not in use: Swivel the paper tower holder.

Remove the faucet and sink before lifting and turning down the right side shelf.

Lift and turn down the garbage bag holder.

Lift and turn down the left side shelf.

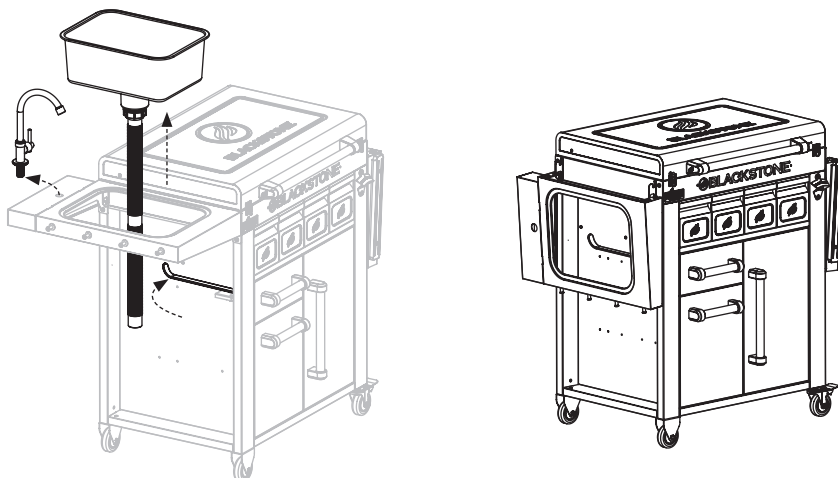

#### ASSEMBLY VIDEOS

View Product Assembly and Technical Support videos online at [blackstoneproducts.com/support](https://blackstoneproducts.com/support) and on YouTube @BlackstoneGriddles

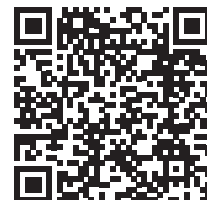



SERVIR ET STOCKER LE

# CHARIOT DE PRÉPARATION

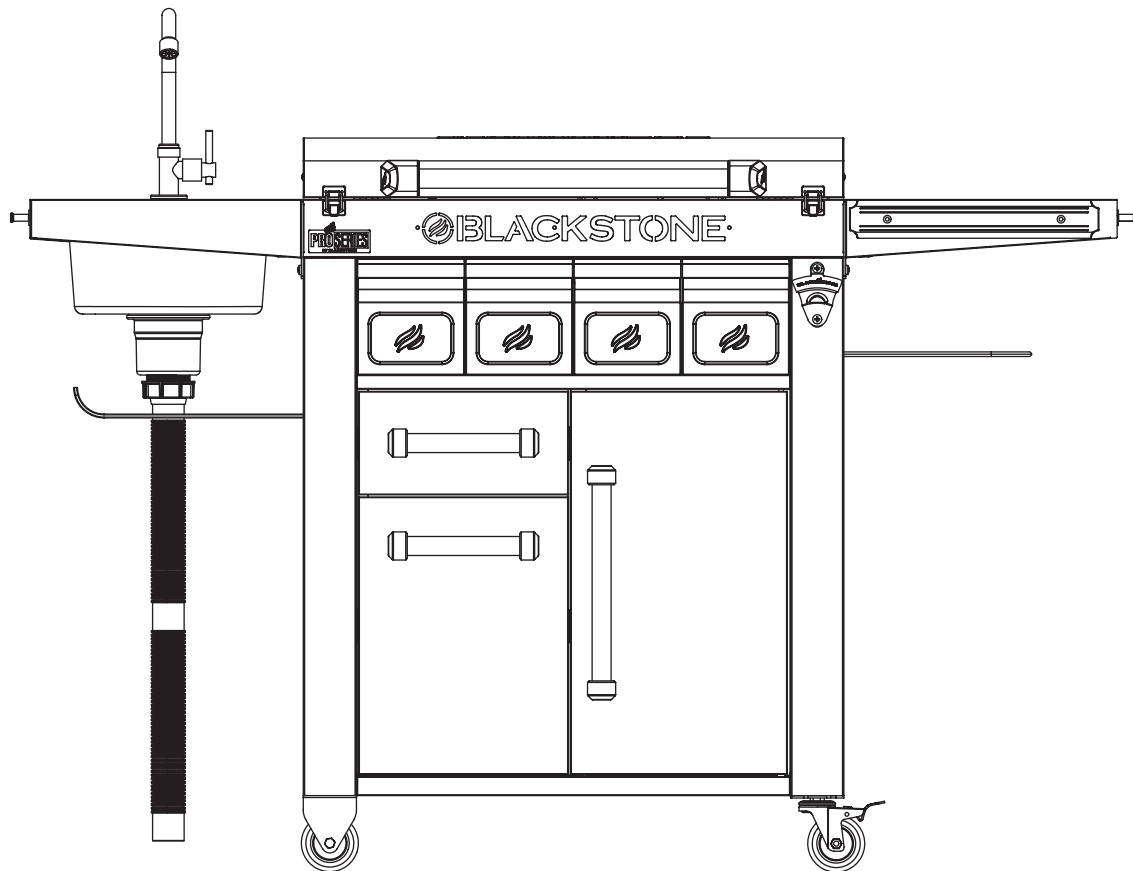



# TABLE DES MATIÈRES

*Il incombe au consommateur de s'assurer que l'unité est correctement assemblée, installée et entretenue. Si vous ne suivez pas les instructions de ce manuel, vous risquez des blessures corporelles et/ou des dégâts matériels.*

## CONTENU

01. GARANTIE .....	01
02. GUIDE DE MONTAGE .....	02

### MESSAGES RELATIFS À LA SÉCURITÉ

Lisez et suivez tous les avertissements qui se trouvent dans ce manuel.

#### DANGER

Indique une situation extrêmement dangereuse qui, si elle n'est pas évitée, peut entraîner des blessures graves, voire mortelles.

#### ATTENTION

Indique la possibilité de blessures corporelles graves si les instructions ne sont pas suivies.

#### MISE EN GARDE

Indique une situation potentiellement dangereuse qui, si elle n'est pas évitée, peut entraîner des blessures légères ou modérées.



# GARANTIE D'UN AN DE NORTH ATLANTIC IMPORTS LLC

North Atlantic Imports, le fabricant, garantira toutes les pièces, la fabrication et les finitions pendant un an. Le fabricant aura le choix de réparer ou de remplacer l'un des éléments ci-dessus. Toutes les garanties sont limitées à l'acheteur d'origine uniquement. Cette garantie ne couvre pas la responsabilité de North Atlantic Imports, de ses agents ou de ses employés, pour les dommages indirects ou consécutifs résultant d'une violation de garantie. L'acheteur doit suivre les instructions d'utilisation du fabricant.

Le fabricant n'est en aucun cas responsable des dommages résultant de l'incapacité à utiliser correctement l'appareil de cuisson. Il incombe à l'acheteur d'établir la période de garantie en vérifiant la date d'achat d'origine à l'aide du reçu de vente.

*Pour une explication plus approfondie de la garantie, lisez le message ci-dessous:*

North Atlantic Imports LLC garantit au propriétaire que le produit couvert par cet accord est exempt de défauts de matériaux et de fabrication dans des conditions normales d'utilisation et de service pour lesquelles il a été conçu si, mais seulement si, il a été utilisé conformément à North Atlantic Imports LLC. instructions exclusivement à usage domestique, et non à des fins associatives privées ou publiques, institutionnelles ou commerciales.

L'obligation de North Atlantic Imports LLC en vertu de cette garantie est limitée au remplacement ou à la réparation, gratuitement, de toute pièce ou pièces qui pourraient s'avérer, à la satisfaction de North Atlantic Imports LLC, être défectueuses dans des conditions normales d'utilisation et d'entretien à domicile dans les périodes indiquées ci-dessous. de temps à compter de la date d'achat ; pendant un an à compter de l'achat, toutes les pièces, la finition et la fabrication. Si un non-respect de cette garantie devenait apparent pendant les périodes de garantie applicables indiquées ci-dessus, l'acheteur d'origine doit informer North Atlantic Imports LLC de la violation de la garantie pendant la période de garantie applicable.

North Atlantic Imports LLC, après notification et conformité de l'acheteur d'origine à ces instructions, corrigera cette non-conformité en réparant ou en remplaçant la ou les pièces défectueuses.

La correction de la manière indiquée ci-dessus constituera l'accomplissement de toutes les obligations de North Atlantic Imports LLC en ce qui concerne la qualité du produit.

North Atlantic Imports LLC ne garantit pas que cet équipement réponde aux exigences de tout code de sécurité d'un État, d'une municipalité ou d'une autre juridiction, et l'acheteur d'origine assume tous les risques et toutes les responsabilités résultant de son utilisation, qu'elle soit utilisée conformément à North Atlantic Imports. instructions LLC ou autre.

Cette garantie ne couvre pas et est destinée à exclure toute responsabilité de la part de North Atlantic, ses agents, préposés ou employés que ce soit en vertu de cette garantie ou implicite par la loi pour tout dommage indirect ou consécutif pour violation de toute garantie. L'acheteur doit établir toutes les périodes de garantie applicables conformément à cette garantie en vérifiant la date d'achat d'origine











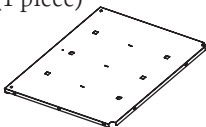

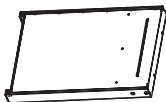
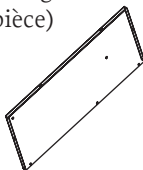
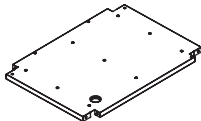

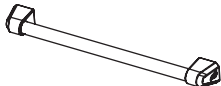
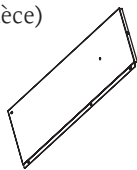

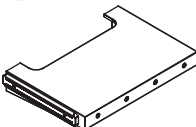
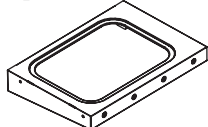
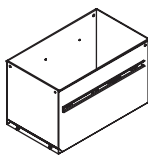

en produisant le reçu de vente daté. Cette garantie ne s'appliquera pas à ce produit ou à toute autre partie de celui-ci qui a fait l'objet d'un accident, d'une négligence, d'une altération, d'un abus ou d'une mauvaise utilisation ou qui a été réparé ou modifié sans le consentement écrit de North Atlantic, en dehors de l'usine North Atlantic Imports LLC. La garantie complète du fabricant n'est pas valable pour les plaques chauffantes achetées auprès de revendeurs tiers sans licence, achetées à prix réduit en raison de pièces manquantes ou endommagées, ou achetées comme modèle de sol ; à la discrétion des Importations de l'Atlantique Nord.

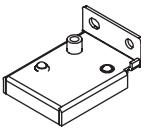
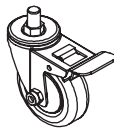
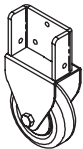
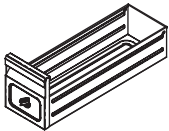
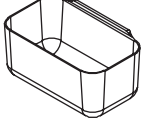
North Atlantic Imports LLC n'offre aucune garantie concernant les accessoires ou les pièces qui ne sont pas fournis avec. Cette garantie ne s'appliquera qu'à l'intérieur des frontières des États-Unis d'Amérique. Cette garantie donne à l'acheteur d'origine des droits spécifiques, et l'acheteur d'origine peut également avoir d'autres droits, qui varient d'un État à l'autre.

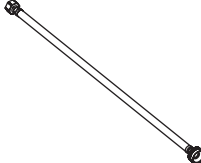
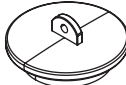











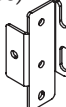

# GUIDE DE MONTAGE

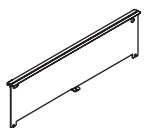
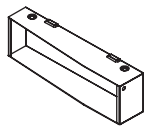
## LISTE DES PIÈCES ILLUSTRÉES

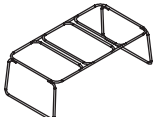
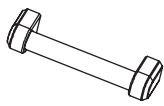
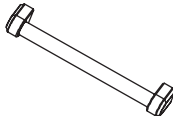
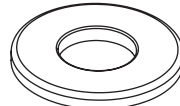
<b>N° 1 BOÎTE</b>	<b>1</b> Panneau de tiroir supérieur (1 pièce) 	<b>2</b> Assemblage de la jambe gauche (1 pièce) 	<b>3</b> Assemblage de la jambe droite (1 pièce) 	<b>N° 6 BOÎTE</b> <i>Intérieur N° 1 Boîte</i>	<b>4</b> Panneau arrière gauche (1 pièce) 
<b>N° 2 BOÎTE</b>	<b>5</b> Bottom panel (1 pièce) 	<b>6</b> Plateau de table (1 pièce) 	<b>7</b> Poignée de couvercle (1 pièce) 	<b>8</b> Panneau arrière droit (1 pièce) 	<b>9</b> Porte de chariot (1 pièce) 
<b>10</b> Support sac poubelle (1 pièce) 	<b>11</b> Panneau de tiroir central (1 pièce) 	<b>N° 7 BOÎTE</b> <i>Intérieur N° 2 Boîte</i>	<b>12</b> Tablette latérale droite (1 pièce) 	<b>13</b> Tablette latérale gauche (1 pièce) 	<b>N° 8 BOÎTE</b> <i>Intérieur N° 7 Boîte</i>
<b>N° 3 BOÎTE</b>	<b>14</b> Tiroir inférieur (1 pièce) 	<b>15</b> Porte-serviettes en papier (1 pièce) 	<b>16</b> Support porte-essuie-tout (1 pièce) 	<b>17</b> Roulettes (2 pièces) 	<b>18</b> Roues fixes (2 pièces) 
<b>19</b> Petits tiroirs (2 pièces) 	<b>20</b> Boîtes d'assaisonnement (4 pièces) 	<b>21</b> Couvercles de boîte d'assaisonnement (4 pièces) 	<b>22</b> Tuyau de robinet (1 pièce) 	<b>23</b> Bouchon de tiroir inférieur (1 pièce) 	<b>24</b> Joint intérieur (1 pièce) 
<b>25</b> Joint extérieur (1 pièce) 	<b>26</b> Couvercle de filtre (1 pièce) 	<b>27</b> Filtre (1 pièce) 	<b>28</b> Inner water output (1 pièce) 	<b>29</b> Outer water output (1 pièce) 	

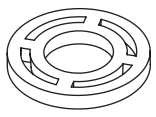
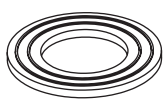
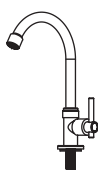

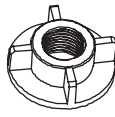
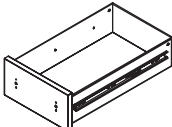
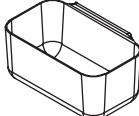

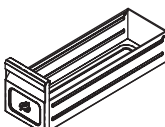
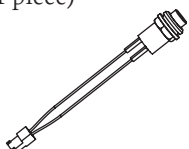
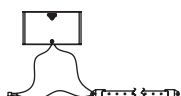
<b>N° 9 BOÎTE</b> <i>Intérieur N° 3 Boîte</i>	<b>30</b> Support de tablette latérale avant gauche (1 pièce) 	<b>31</b> Support de tablette latérale avant droite (1 pièce) 	<b>32</b> Support de tablette latérale arrière gauche (1 pièce) 	<b>33</b> Support de tablette latérale arrière droite (1 pièce) 	<b>34</b> Ouvre-bouteille (1 pièce) 
<b>35</b> Planches d'espacement (3 pièces) 	<b>36</b> Panneau de support de robinet (1 pièce) 	<b>N° 4 BOÎTE</b>	<b>37</b> Écrou en plastique (1 pièce) 	<b>38</b> Évier (1 pièce) 	<b>39</b> Support de boîte d'assaisonnement (1 pièce) 
<b>N° 10 BOÎTE</b> <i>Intérieur N° 4 Boîte</i>	<b>40</b> Poignées de tiroir (2 pièces) 	<b>41</b> Poignée de porte (1 pièce) 	<b>42</b> Base de robinet (1 pièce) 	<b>43</b> Façade du tiroir inférieur (1 pièce) 	<b>44</b> Tube d'eau en plastique (1 pièce) 
<b>45</b> Anneau femelle en silicone (1 pièce) 	<b>46</b> Anneau mâle en silicone (1 pièce) 	<b>47</b> Robinet (1 pièce) 	<b>48</b> Crochets en métal (4 pièces) 	<b>49</b> Écrou de robinet (1 pièce) 	
<b>N° 5 BOÎTE</b>	<b>50</b> Tiroir supérieur (1 pièce) 	<b>51</b> Boîtes d'assaisonnement (4 pièces) 	<b>52</b> Couvercles de boîte d'assaisonnement (4 pièces) 	<b>53</b> Petits tiroirs (2 pièces) 	
<b>N° 11 BOÎTE</b>	<b>54</b> Assemblage de bouton LED (1 pièce) 	<b>55</b> Bande LED et batterie (1 pièce) 			

**56** Pack matériel (1 pièce)

- a. Vis M6x12  
(15 pièces) (17 pièces) (15 pièces)
- b. Boulons étagés M6x20 (12 pièces)
- c. Supports d'étagère (8 pièces)
- d. Rondelles pour chevilles d'étagère  
(8 pièces)
- e. Rondelles (2 pièces)
- f. Écrous à embase M4 (2 pièces)
- g. Vis à tôle (6 pièces)
- h. Vis M4x10 (17 pièces) (16 pièces)

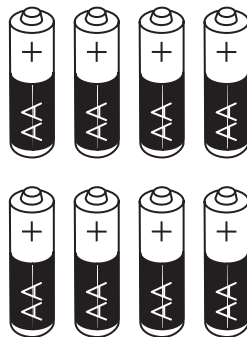
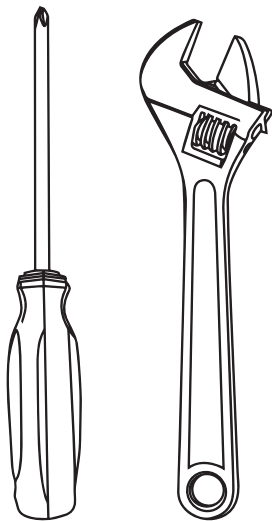
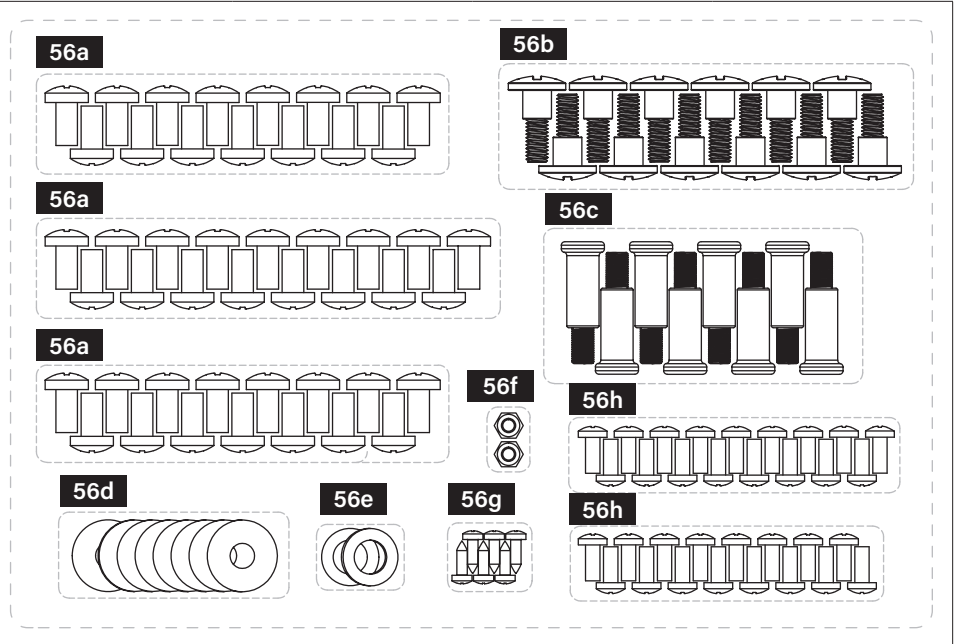

**OUTILS NÉCESSAIRES:**  
Tournevis cruciforme et Clé à molette

**NON INCLUS:**  
Huit (8) piles AA



## INSTRUCTIONS DE MONTAGE

*Veillez lire attentivement toutes les instructions avant de continuer. Assurez-vous que tous les matériaux d'emballage en plastique et toute protection de transport sont retirés avant l'assemblage.*

Trouvez une grande surface propre pour assembler votre gril. Veuillez vous référer à la liste des pièces et aux schémas d'assemblage si nécessaire.

**ÉTAPE 01** Retirez l'assemblage du pied de joint de l'emballage. Desserrez les quatre (4) vis et séparez les ensembles de pieds gauche et droit.

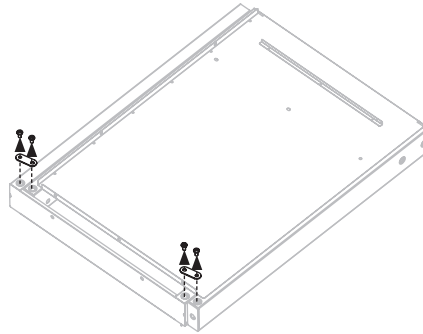

**ÉTAPE 02** Utilisez trois (3) vis M4x10 (h.) pour installer le pied gauche sur le panneau inférieur.

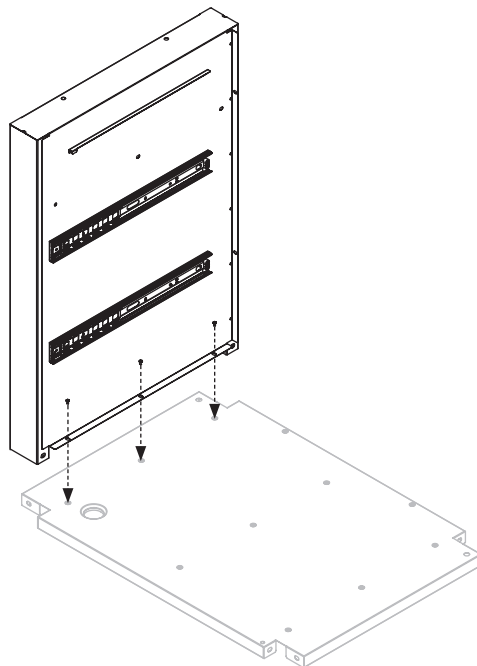

### ⚠ ATTENTION

Le fabricant a tout mis en œuvre pour éliminer les bords tranchants. Cependant, vous devez manipuler tous les éléments avec soin pour éviter les blessures accidentelles.

Certaines pièces peuvent comporter des bords tranchants, notamment celles indiquées dans ces instructions. Portez des gants de protection si nécessaire.

### ⚠ ATTENTION

L'utilisation d'alcool, de médicaments sur ordonnance ou en vente libre peut nuire à la capacité du consommateur d'assembler correctement ou d'utiliser cet appareil en toute sécurité.

### ⚠ MISE EN GARDE

Il est recommandé de monter ce produit à deux personnes.



**ÉTAPE 03** Utilisez trois (3) vis M4x10 (**h.**) pour installer le pied droit sur le panneau inférieur.

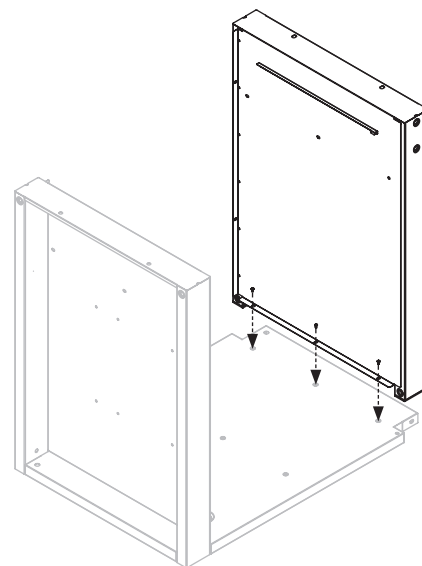

**ÉTAPE 04** Avec l'aide d'une autre personne, posez le chariot sur le dos. Utilisez quatre (4) vis M6x12 (**a.**) pour fixer les deux (2) roues fixes au pied gauche. Utilisez quatre (4) vis M6x12 (**a.**) pour fixer le pied droit au panneau inférieur, puis insérez les roulettes dans le pied droit.

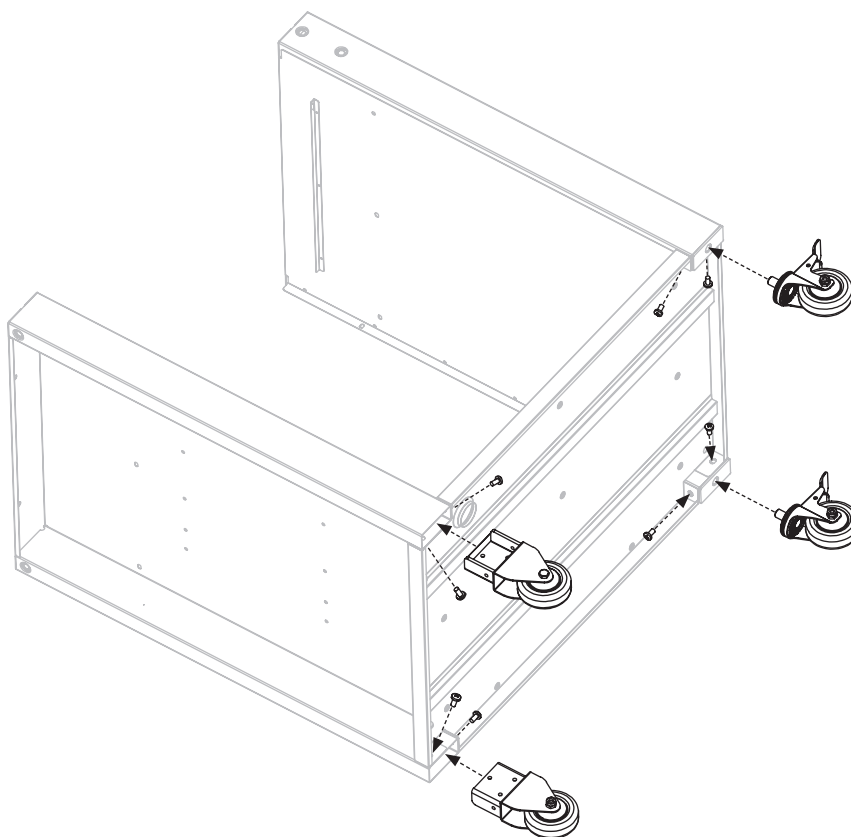



**ÉTAPE 05** Avec l'aide d'une autre personne, placez le chariot sur ses pieds et utilisez deux (2) vis M6x12 (a.) pour fixer les roues fixes.

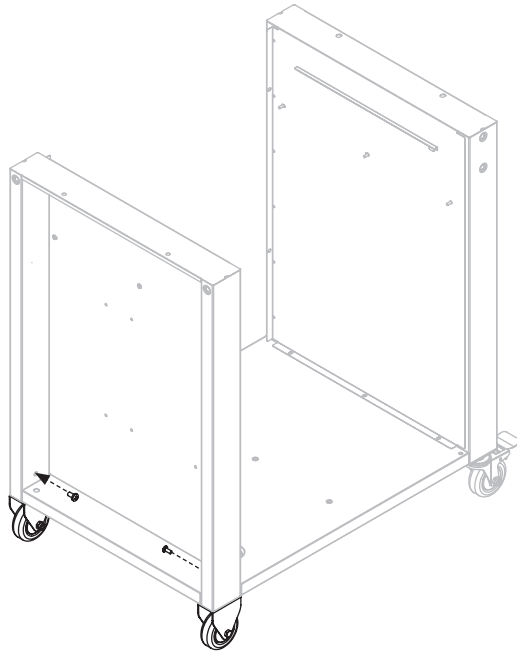

**ÉTAPE 06** Utilisez trois (3) vis M4x10 (h.) pour fixer le panneau arrière droit au pied droit et au panneau inférieur.

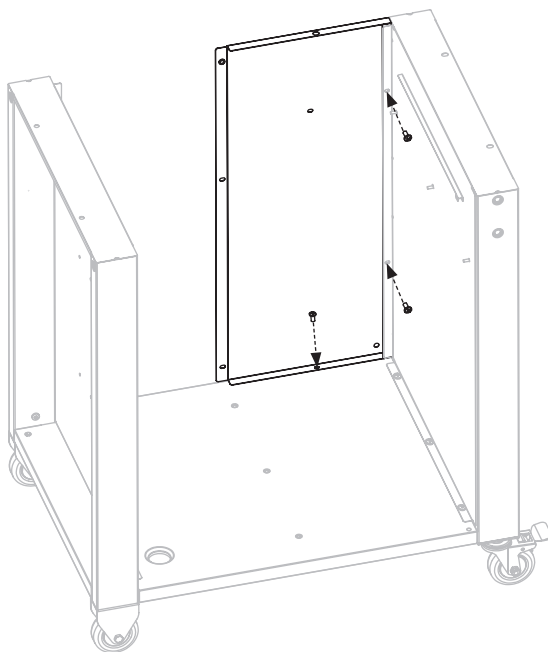



**ÉTAPE 07** Utilisez trois (3) vis M4x10 (**h.**) pour fixer le panneau arrière gauche au pied gauche et au panneau inférieur. Utilisez une (1) vis M4x10 (**h.**) pour fixer le panneau arrière gauche au panneau arrière droit.

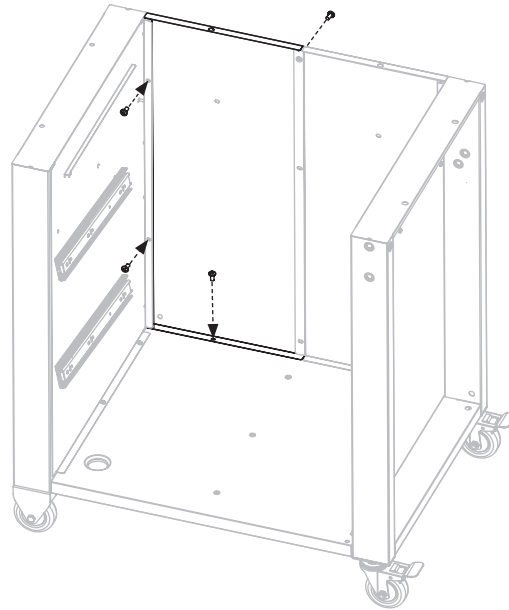

**ÉTAPE 08** Avec l'aide d'une autre personne, placez le plateau de table sur le chariot. Utilisez quatre (4) vis M6x12 (**a.**) pour fixer la table aux pieds gauche et droit (deux (2) par côté). Utilisez deux (2) vis M6x12 (**a.**) pour fixer la table aux panneaux arrière.

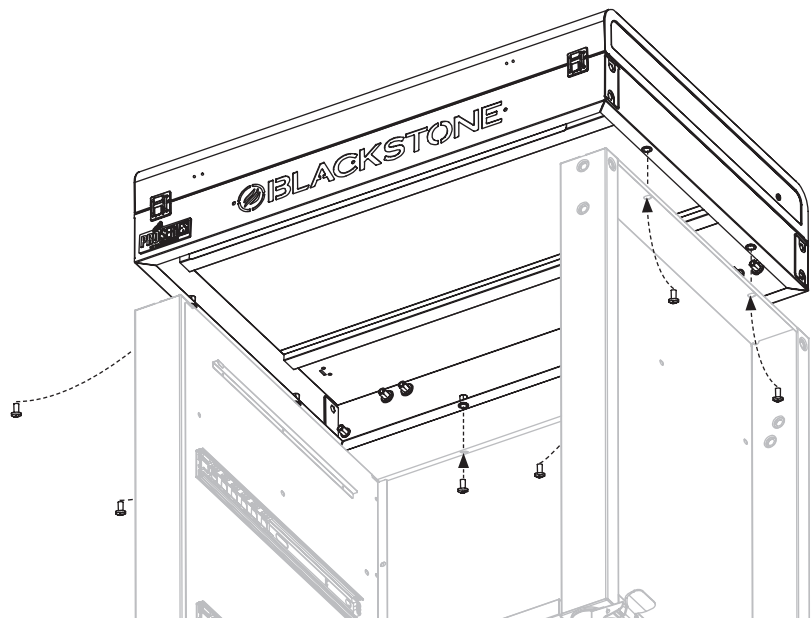



**ÉTAPE 09** Utilisez trois (3) vis M4x10 (**h.**) pour fixer le panneau du tiroir central au panneau inférieur.

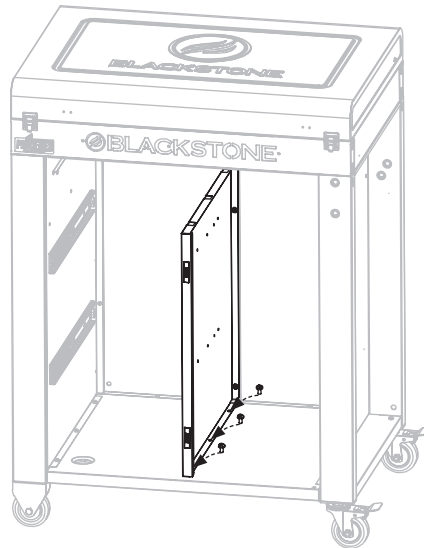

Utilisez deux (2) vis M4x10 (**h.**) pour fixer le panneau central du tiroir aux panneaux arrière.

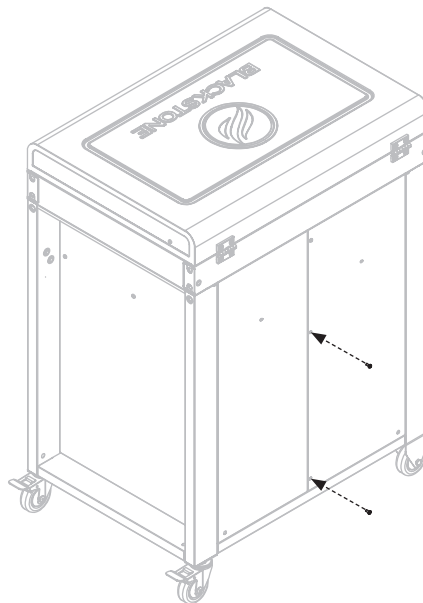

**ÉTAPE 10** Utilisez six (6) vis autotaraudeuses M3 pour fixer les trois (3) planches d'espacement (**g.**) au panneau du tiroir supérieur.

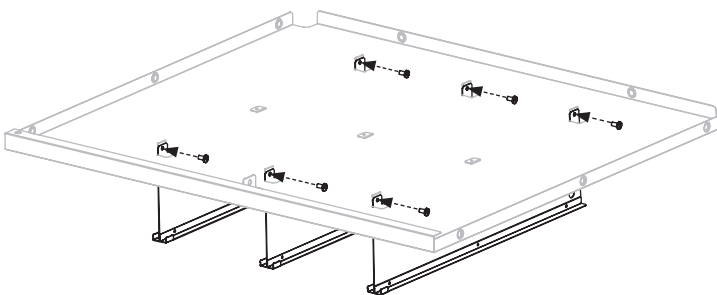



**ÉTAPE 11** Alignez le panneau d'espacement central de sorte qu'il s'insère dans les fentes supérieures du panneau central du tiroir. Utilisez six (6) vis M4x10 (**h.**) pour fixer le panneau du tiroir supérieur aux pieds, et une (1) vis M4x10 (**h.**) pour fixer le panneau du tiroir supérieur au panneau du tiroir central.

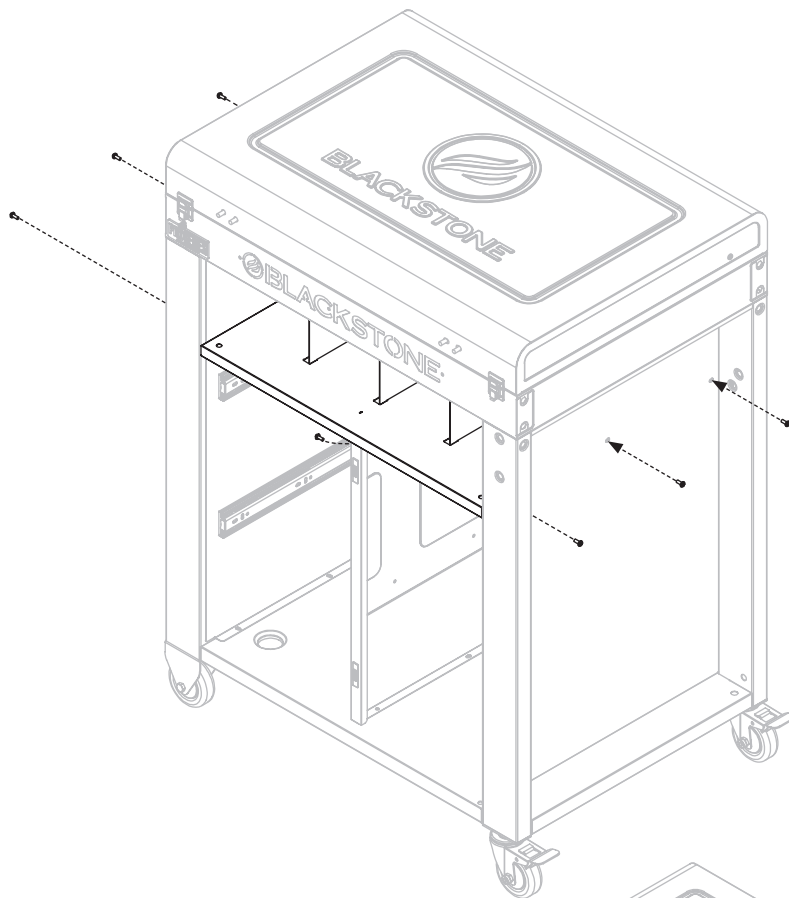

Utilisez deux (2) vis M4x10 (**h.**) pour fixer le panneau du tiroir supérieur aux panneaux arrière.

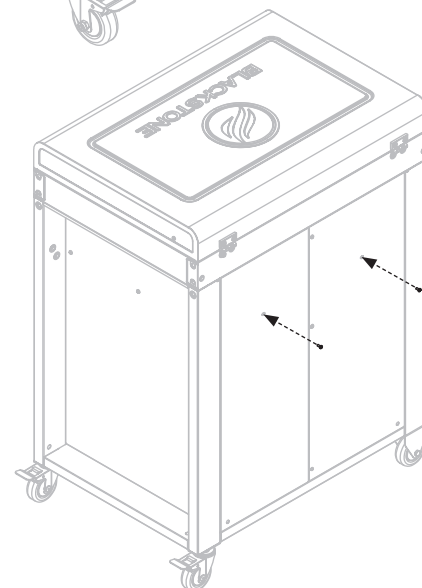





**ÉTAPE 12** Utilisez deux (2) vis M6x12 (a.) pour fixer une (1) poignée de porte à la porte droite du chariot.

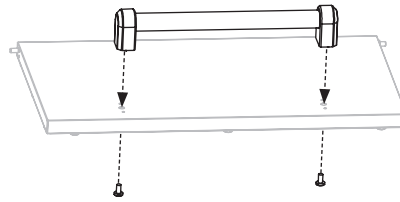

**ÉTAPE 13** Fixez la porte droite du chariot au chariot en ① insérant d'abord l'axe de charnière de porte inférieure, puis ② en insérant l'axe de charnière de porte supérieure.

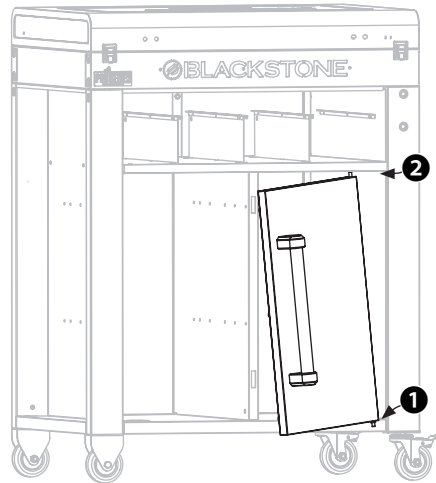

**ÉTAPE 14** Utilisez deux (2) vis M6x12 (a.) pour fixer une (1) poignée de tiroir à la plaque avant du tiroir inférieur.

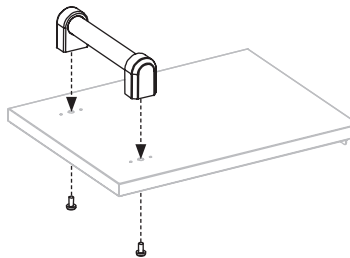

Utilisez quatre (4) vis M4x10 (h.) pour fixer la plaque avant du tiroir inférieur au tiroir inférieur.

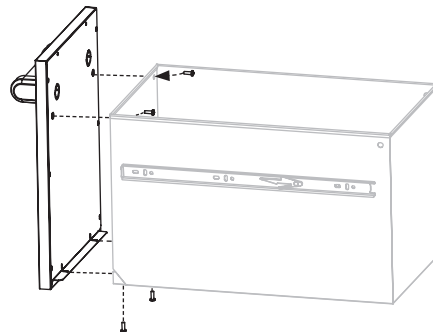



**ÉTAPE 15** Insérez le bouchon dans le trou prédécoupé du tiroir inférieur.

Retirez le rail inférieur du tiroir.

Alignez le rail du tiroir entre le tiroir inférieur et le chariot, puis faites glisser le tiroir inférieur en place.

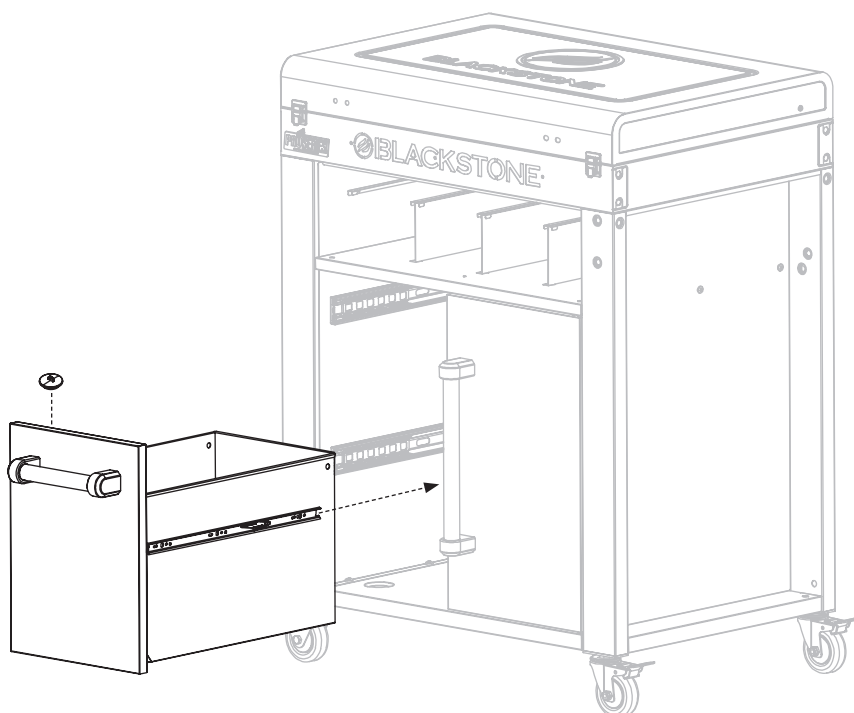

**ÉTAPE 16** Utilisez deux (2) vis M6x12 (a.) pour fixer une (1) poignée de tiroir au tiroir supérieur.

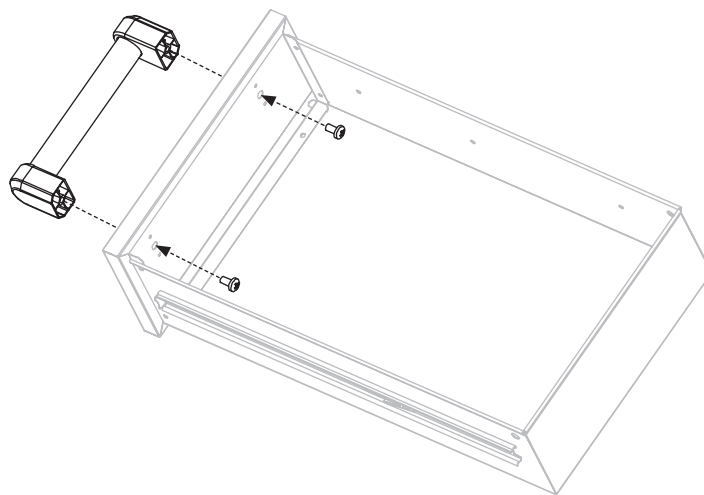



**ÉTAPE 17** Retirez le rail du tiroir supérieur.

Alignez le rail du tiroir entre le tiroir supérieur et le chariot, puis faites glisser le tiroir supérieur en place.

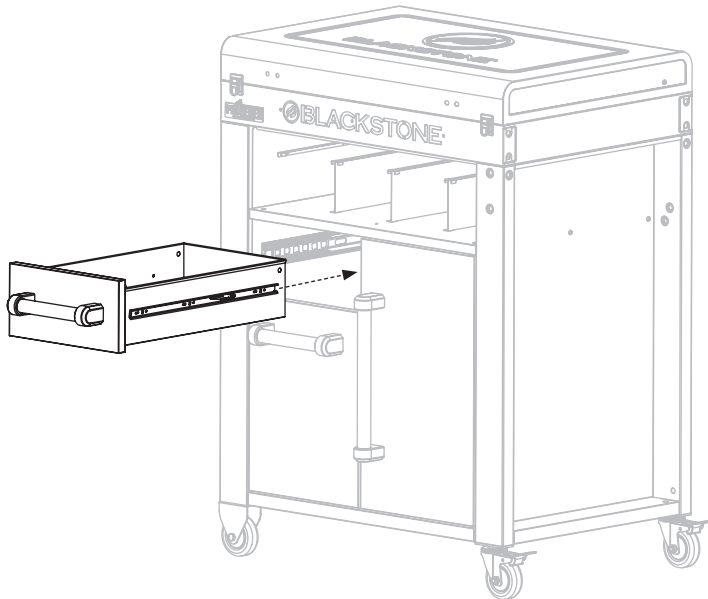

**ÉTAPE 18** Inclinez les quatre (4) petits tiroirs et faites-les glisser en place.

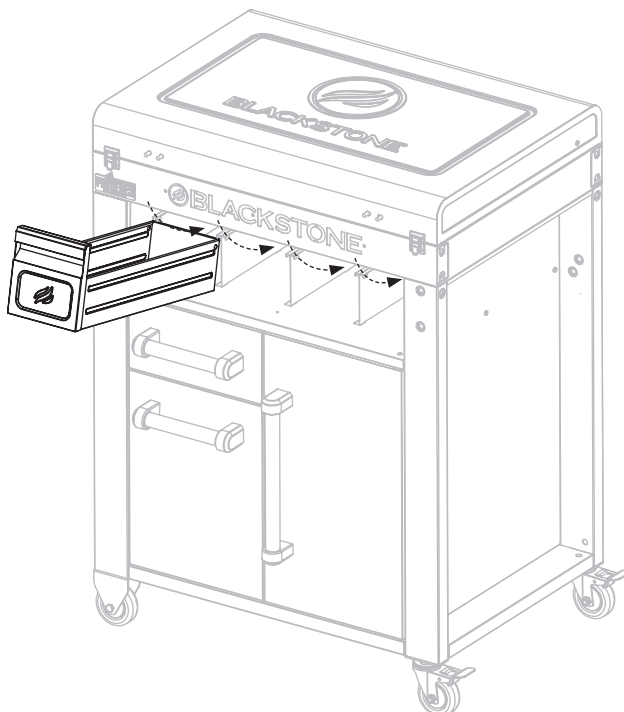



**ÉTAPE 19** Utilisez deux (2) vis M6x12 (**a.**) pour fixer le support de serviette en papier sur le côté gauche du chariot.

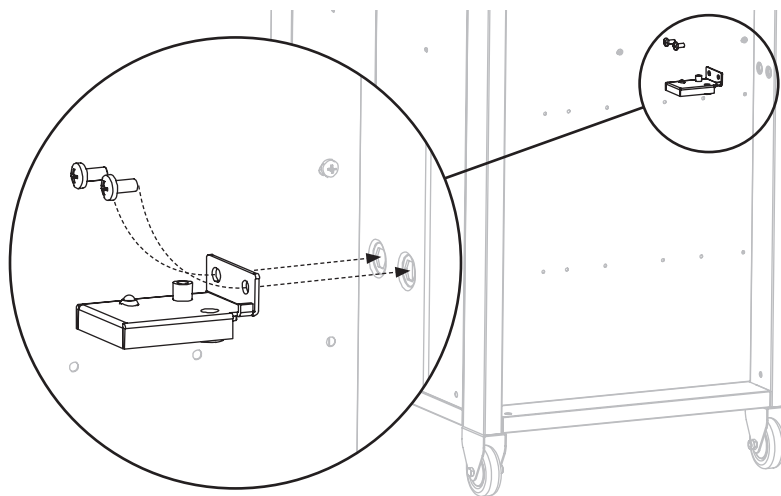

**ÉTAPE 20** Utilisez une (1) vis M6x12 (**a.**) et deux (2) rondelles (**e.**) pour fixer le support de la tour de papier sur le support de la serviette en papier.

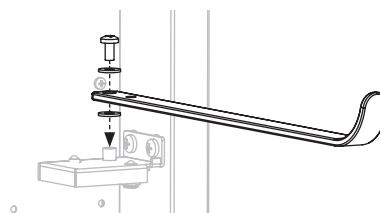

**ÉTAPE 21** Vissez deux (2) boulons étagés M6x20 (**b.**) dans les trous inférieurs du pied droit.

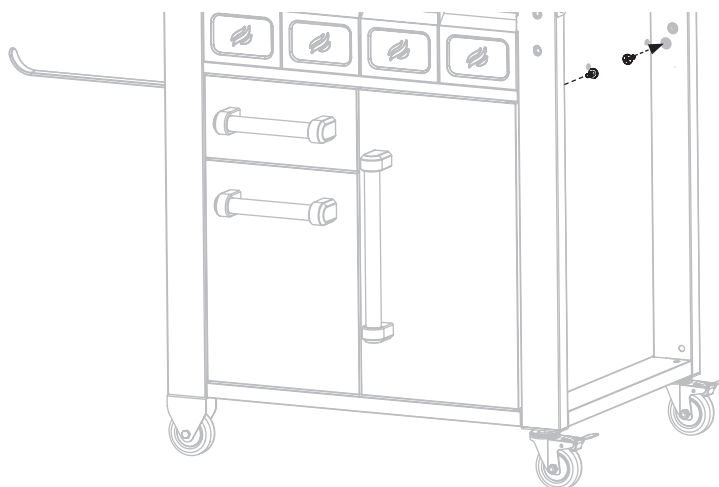



**ÉTAPE 22** Utilisez deux (2) boulons étagés M6x20 (**b.**) pour attacher le support de sac poubelle au pied droit.

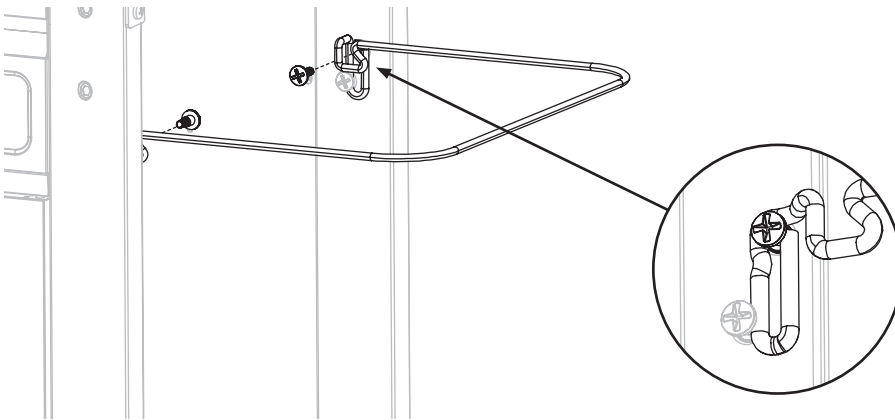

**ÉTAPE 23** Utilisez sept (7) vis M6x12 (**a.**) pour fixer deux (2) supports de tablette du côté droit au côté droit du chariot.

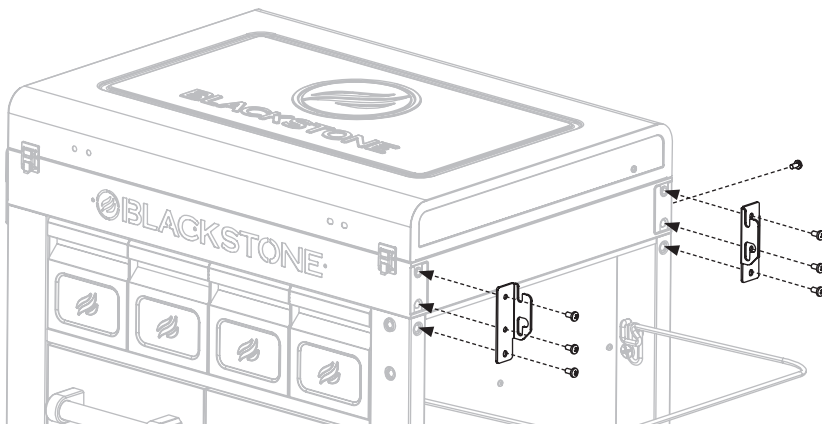

**ÉTAPE 24** Utilisez sept (7) vis M6x12 (**a.**) pour fixer deux (2) supports de tablette latérale gauche au côté gauche du chariot.

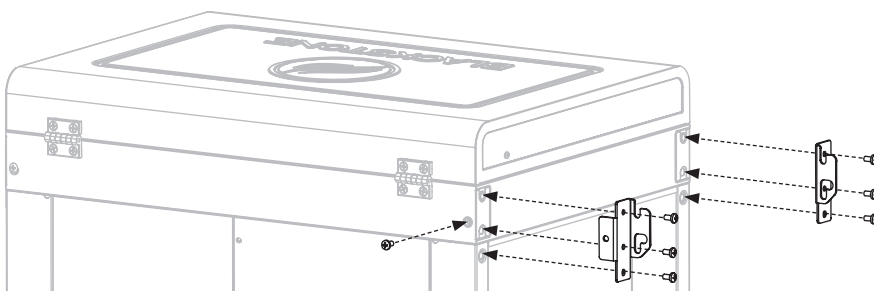

**MISE EN GARDE**

Le poids maximum sur la tablette latérale est de de 4,5 kg (10 lb).

**ÉTAPE 25** Vissez deux (2) boulons à épaulement M6x20 (**b.**) dans les trous supérieurs de la tablette latérale droite.

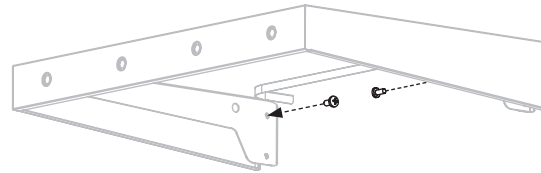

**ÉTAPE 26** Utilisez deux (2) vis M6x12 (**a.**) pour fixer le panneau de support du robinet à la tablette latérale gauche.

Vissez deux (2) boulons à épaulement M6x20 (**b.**) dans les trous supérieurs de la tablette latérale gauche.

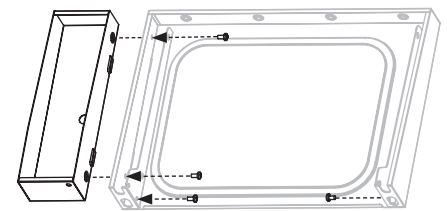

**ÉTAPE 27** Accrochez les boulons de la tablette latérale droite sur les supports de la tablette latérale. Vissez deux (2) boulons à épaulement M6x20 (**b.**) dans les trous inférieurs des supports pour fixer la tablette latérale droite aux supports de tablette.

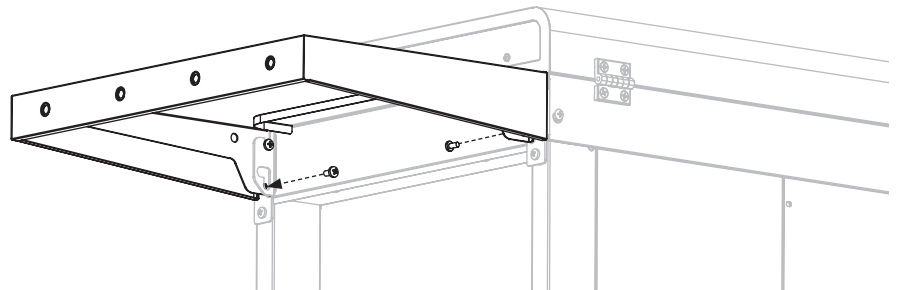

**ÉTAPE 28** Accrochez les boulons de la tablette latérale gauche sur les supports de la tablette latérale. Vissez deux (2) boulons à épaulement M6x20 (**b.**) dans les trous inférieurs des supports pour fixer la tablette latérale gauche aux supports de tablette.

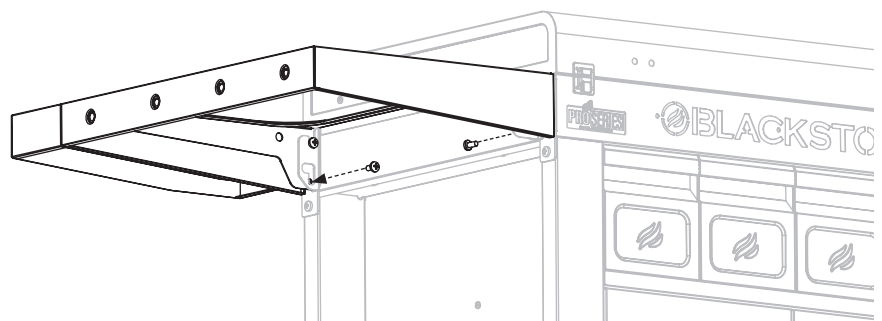



**ÉTAPE 29** Fixez les quatre (4) chevilles de tablette latérale (**c.**) et quatre (4) rondelles de fixation (**d.**) aux deux tablettes latérales en les vissant dans les trous prédécoupés.



**ÉTAPE 30** Installez le joint intérieur, la sortie d'eau intérieure, le filtre et le couvercle du filtre au fond de l'évier.

Placez le joint extérieur contre le fond de l'évier et vissez la sortie d'eau extérieure dans la sortie d'eau intérieure.

Utilisez l'écrou en plastique pour fixer le tube d'eau en plastique à la sortie d'eau extérieure.

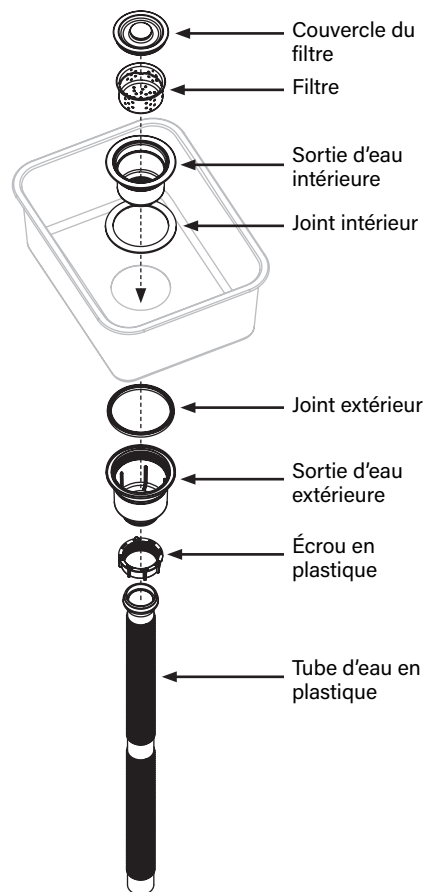



**ÉTAPE 31** Placez l'évier dans la tablette latérale gauche.  
(Dirigez le tube d'eau en plastique dans un seau ou un autre récipient.)

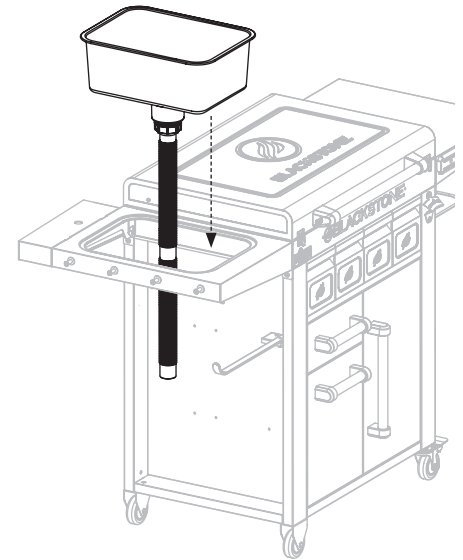

**ÉTAPE 32** Utilisez deux (2) vis M6x12 (a.) pour fixer le décapsuleur à l'avant du pied droit.

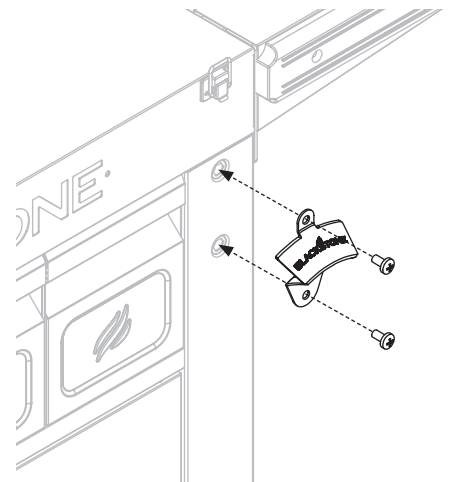

**ÉTAPE 33** Fixez la base du robinet et la bague en silicone femelle sur le fond du robinet.

Insérez le robinet dans le trou prédécoupé du panneau de support du robinet, puis fixez l'anneau en silicone mâle et l'écrou du robinet à l'extrémité du robinet.

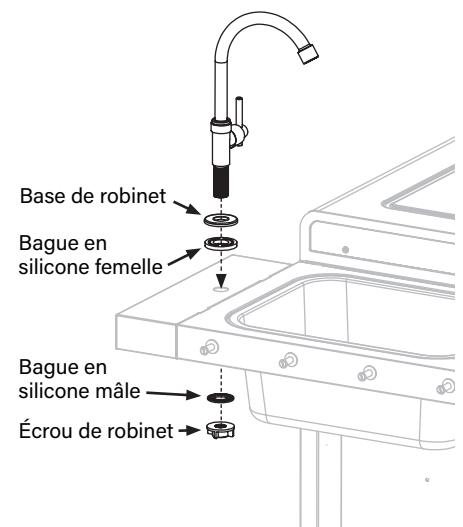





**ÉTAPE 34** Fixez le tuyau du robinet au robinet. Un tuyau d'arrosage standard (non inclus) peut maintenant être connecté au tuyau du robinet.

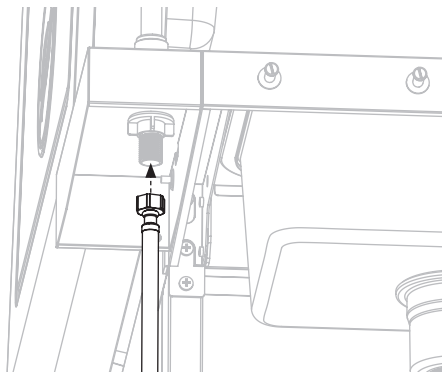

### ⚠ ATTENTION

- Ne mélangez pas des piles anciennes et neuves.
- Ne mélangez pas des piles alcalines, standard (carbène-zinc) ou rechargeables (ni-cad, ni-mh, etc.).

**ÉTAPE 35** Sous le couvercle, retirez les six (6) vis M4x10 du support de DEL et du couvercle du bloc-batterie.

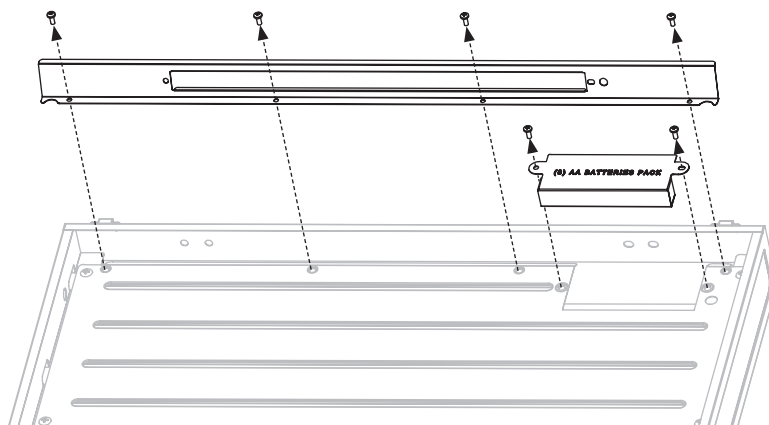

**ÉTAPE 36** Insérez huit (8) piles AA (non incluses) dans la batterie.

Fixez la batterie au couvercle de la batterie.

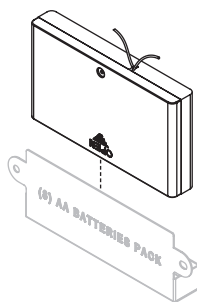

**ÉTAPE 37** Utilisez deux (2) vis M4x10 (**h.**) et deux (2) écrous M4 (**f.**) pour fixer la bande LED au support LED.

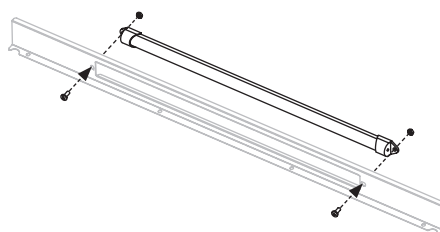



**ÉTAPE 38** Enfilez l'assemblage du bouton LED à travers le trou sous le couvercle et connectez-le à la borne de la batterie.

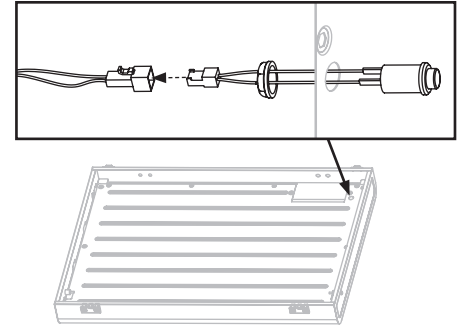

**ÉTAPE 39** Utilisez quatre (4) vis M6x12 (a.) pour fixer la poignée du couvercle au couvercle.

Remettez le couvercle de la batterie en place avec la batterie en dessous.  
Remettez en place le support LED.

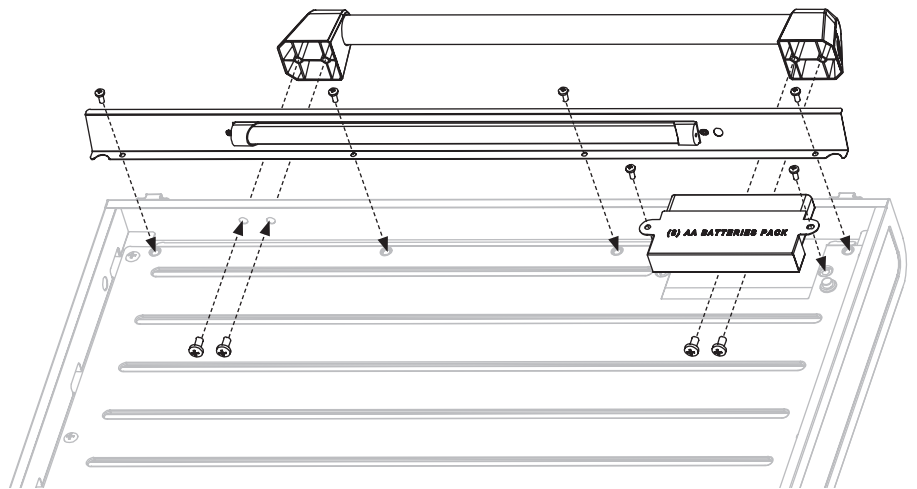

**ÉTAPE 40** Accrochez les huit (8) boîtes d'assaisonnement et les quatre (4) crochets métalliques sur les fentes à l'intérieur du couvercle.

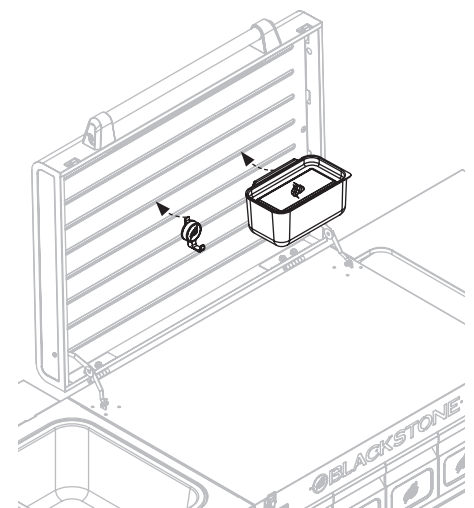



**ÉTAPE 41** Profitez de la cuisine en plein air avec votre Servir et stocker le chariot de préparation Blackstone!

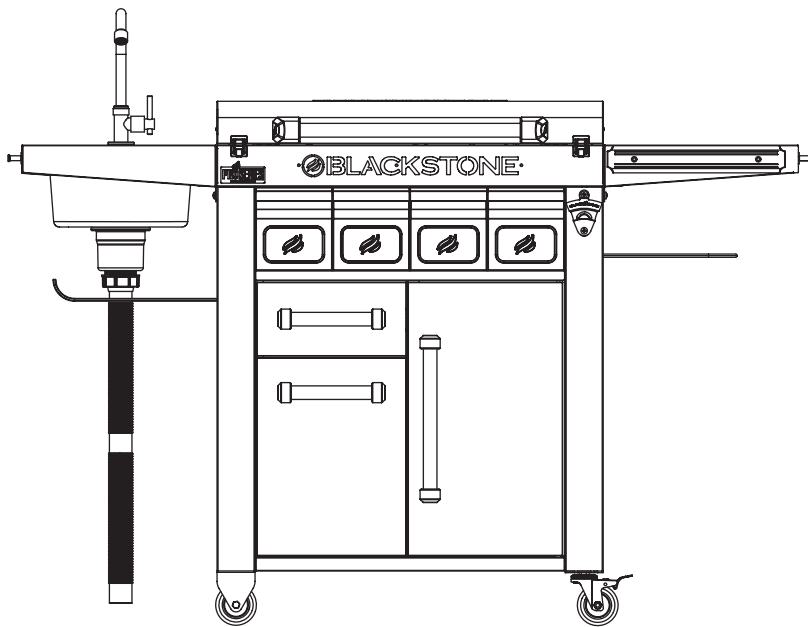

Lorsqu'il n'est pas utilisé: faites pivoter le support de la tour papier.

Retirez le robinet et l'évier avant de soulever et d'abaisser la tablette latérale droite.

Soulevez et abaissez le support du sac poubelle.

Soulevez et abaissez la tablette latérale gauche.

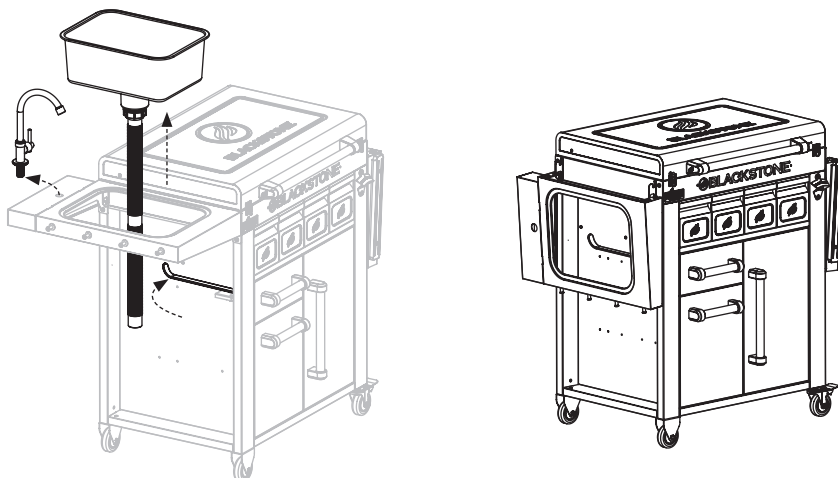

#### VIDÉOS DE MONTAGE

Visionnez les vidéos d'assemblage de produits et d'assistance technique en ligne sur [blackstoneproducts.com/support](https://blackstoneproducts.com/support) et sur YouTube @BlackstoneGriddles

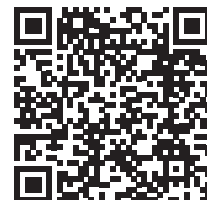



# CARRITO DE PREPARACIÓN

PARA SERVIR Y ALMACENAR

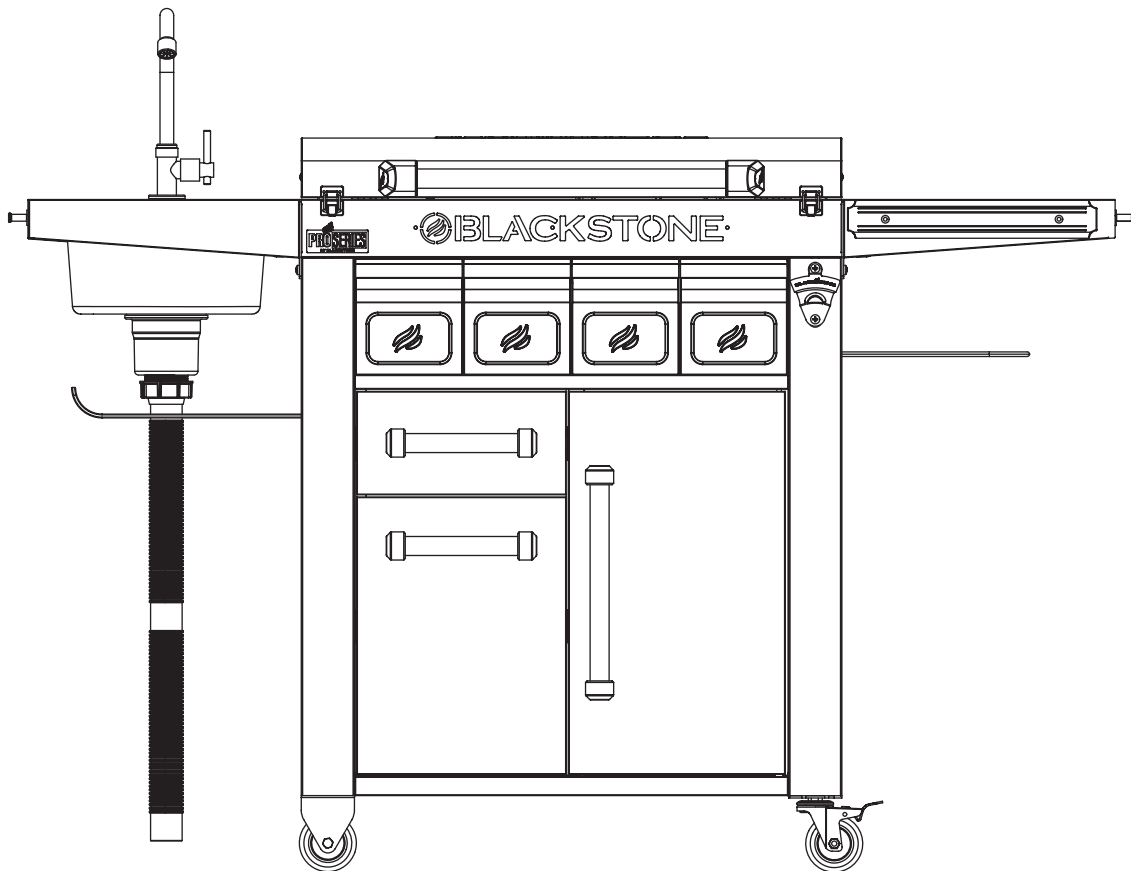



# TABLA DE CONTENIDO

*Es responsabilidad del consumidor asegurarse de que la unidad esté correctamente ensamblada, instalada y mantenida. El incumplimiento de las instrucciones de este manual puede provocar lesiones corporales y / o daños a la propiedad.*

## CONTENIDO

01. GARANTÍA .....	01
02. GUÍA DE MONTAJE .....	02

### LLAVE DE ALERTA DE SEGURIDAD

Lea y siga todos los avisos que se encuentran en el manual.

#### PELIGRO

Indica una situación de peligro inminente que, si no se evita, puede causar la muerte o lesiones graves.

#### ADVERTENCIA

Indica la posibilidad de lesiones corporales graves si no se siguen las instrucciones.

#### PRECAUCIÓN

Indica una situación potencialmente peligrosa que, si no se evita, puede resultar en una lesión moderada.



# NORTH ATLANTIC IMPORTS LLC

## GARANTÍA DE 1 AÑO

North Atlantic Imports, el fabricante, garantizará por un año a partir de la compra a todas las piezas, mano de obra y acabados. Será la opción del fabricante en cuanto a si reparar o reemplazar cualquiera de los elementos anteriores. Todas las garantías están limitadas únicamente al comprador original. Esta garantía no cubre ninguna responsabilidad por parte de North Atlantic Imports, sus agentes o empleados, por cualquier daño indirecto o consecuente por incumplimiento de la garantía. El comprador debe seguir las instrucciones de uso del fabricante.

Bajo ninguna circunstancia, el fabricante es responsable de los daños causados por el hecho de no operar correctamente la estación de cocción. Es responsabilidad del comprador establecer el período de garantía al verificar la fecha de compra original con el recibo de compra original.

*Para obtener una explicación más detallada de la garantía, lea a continuación:*

North Atlantic Imports LLC garantiza al propietario que el producto cubierto por este acuerdo está libre de defectos de material y mano de obra bajo el uso y servicio normal para el cual fue diseñado si, pero solo si, ha sido operado de acuerdo con North Atlantic Imports LLC instrucciones exclusivamente para uso doméstico, y no para club público o privado, institucional o comercial.

La obligación de North Atlantic Imports LLC bajo esta garantía se limita a reemplazar o reparar, sin cargo, cualquier parte o partes que puedan probar, a satisfacción de North Atlantic Imports LLC, ser defectuosas bajo el uso y servicio doméstico normal dentro de los siguientes períodos establecidos de tiempo desde la fecha de compra; durante un año desde la compra, todas las piezas, el acabado y la mano de obra. Si cualquier incumplimiento de esta garantía se hace evidente durante los períodos de garantía aplicables indicados anteriormente, el comprador original debe notificar a North Atlantic Imports LLC del incumplimiento de la garantía dentro del período de garantía aplicable.

North Atlantic Imports LLC, previo aviso y cumplimiento por parte del comprador original de dichas instrucciones, corregirá dicha no conformidad reparando o reemplazando la pieza o piezas defectuosas.

La corrección en la forma provista anteriormente constituirá el cumplimiento de todas las obligaciones de North Atlantic Imports LLC con respecto a la calidad del producto.

North Atlantic Imports LLC no garantiza que este equipo cumpla con los requisitos de ningún código de seguridad de ningún estado, municipio u otra jurisdicción, y el comprador original asume todo el riesgo y la responsabilidad que resulte del uso del mismo, ya sea que se use de acuerdo con North Atlantic Imports. Instrucciones de LLC o de otro tipo.

Esta garantía no cubre y está destinada a excluir cualquier responsabilidad por parte de North Atlantic, sus agentes, servidores o empleados, ya sea bajo esta garantía o implícita por ley, por cualquier daño indirecto o consecuente por incumplimiento de cualquier garantía. El comprador debe establecer todos los períodos de garantía aplicables de conformidad











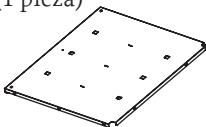

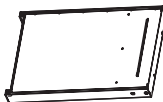
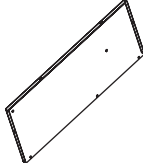
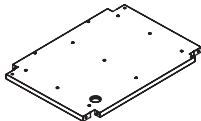

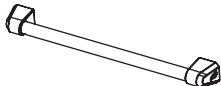
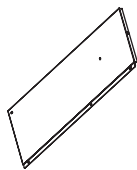

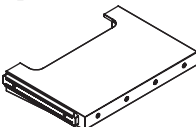
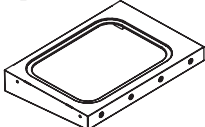
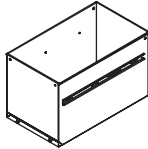

con esta garantía verificando la fecha de compra original mediante la presentación del recibo de venta con fecha. Esta garantía no se aplicará a este producto o cualquier otra parte del mismo que haya sido objeto de accidente, negligencia, alteración, abuso o mal uso o que haya sido reparado o alterado sin el consentimiento por escrito de North Atlantic, fuera de la fábrica de North Atlantic Imports LLC. La garantía completa del fabricante no es válida para planchas compradas a revendedores externos sin licencia, compradas con descuento debido a piezas faltantes o dañadas, o compradas como modelo de piso; a discreción de North Atlantic Imports.

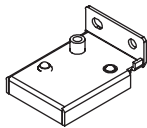
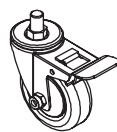
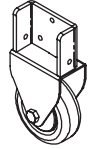
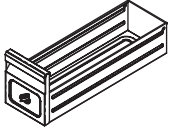
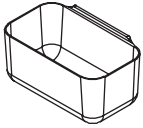
North Atlantic Imports LLC no ofrece garantía alguna con respecto a los accesorios o piezas no suministrados con él. Esta garantía se aplicará únicamente dentro de los límites de los Estados Unidos de América. Esta garantía otorga al comprador original derechos específicos, y el comprador original también puede tener otros derechos, que varían de un estado a otro.

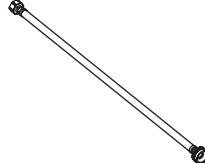
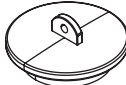













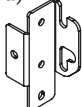
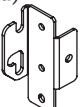

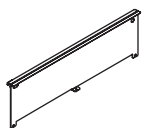
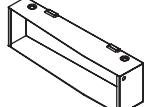

# GUÍA DE MONTAJE

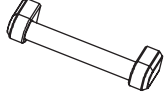
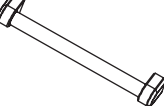
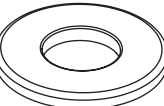
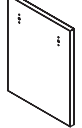
## LISTA DE PIEZAS ILUSTRADA

<b>Nº 1 CAJA</b>	<b>1</b> Panel superior del cajón (1 pieza) 	<b>2</b> Montaje de la pata izquierda (1 pieza) 	<b>3</b> Conjunto de pata derecha (1 pieza) 	<b>Nº 6 CAJA Interior Nº 1 Caja</b>	<b>4</b> Panel trasero izquierdo (1 pieza) 
<b>Nº 2 CAJA</b>	<b>5</b> Panel inferior (1 pieza) 	<b>6</b> Tablero de mesa (1 pieza) 	<b>7</b> Asa de la tapa (1 pieza) 	<b>8</b> Panel trasero derecho (1 pieza) 	<b>9</b> Puerta del carro (1 pieza) 
<b>10</b> Porta bolsa de basura (1 pieza) 	<b>11</b> Panel del cajón central (1 pieza) 	<b>Nº 7 CAJA Interior Nº 2 Caja</b>	<b>12</b> Estante lateral derecho (1 pieza) 	<b>13</b> Estante lateral izquierdo (1 pieza) 	<b>Nº 8 CAJA Interior Nº 7 Caja</b>
<b>Nº 3 CAJA</b>	<b>14</b> Cajón inferior (1 pieza) 	<b>15</b> Portarrollos de papel (1 pieza) 	<b>16</b> Soporte porta toallas de papel (1 pieza) 	<b>17</b> Ruedas giratorias (2 piezas) 	<b>18</b> Ruedas fijas (2 piezas) 
<b>19</b> Cajones pequeños (2 piezas) 	<b>20</b> Cajas de condimentos (4 piezas) 	<b>21</b> Tapas de caja de condimentos (4 piezas) 	<b>22</b> Manguera de grifo (1 pieza) 	<b>23</b> Tapón de cajón inferior (1 pieza) 	<b>24</b> Junta interior (1 pieza) 
<b>25</b> Junta exterior (1 pieza) 	<b>26</b> Tapa de filtro (1 pieza) 	<b>27</b> Filtro (1 pieza) 	<b>28</b> Salida de agua interior (1 pieza) 	<b>29</b> Salida de agua exterior (1 pieza) 	

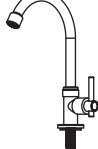

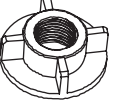
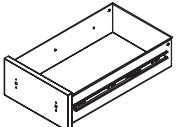
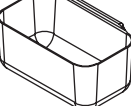

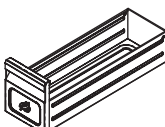
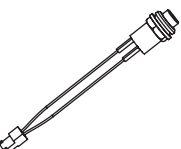
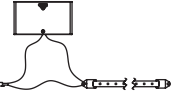
<p><b>Nº 9 CAJA</b> <i>Interior Nº 3 Caja</i></p>	<p><b>30</b> Soporte de estante lateral delantero izquierdo (1 pieza)</p> 	<p><b>31</b> Soporte de estante lateral delantero derecho (1 pieza)</p> 	<p><b>32</b> Soporte del estante lateral trasero izquierdo (1 pieza)</p> 	<p><b>33</b> Soporte del estante lateral trasero derecho (1 pieza)</p> 	<p><b>34</b> Abridor de botellas (1 pieza)</p> 
<p><b>35</b> Tablas espaciadoras (3 piezas)</p> 	<p><b>36</b> Panel soporte grifo (1 pieza)</p> 	<p><b>Nº 4 CAJA</b></p>	<p><b>37</b> Tuerca de plástico (1 pieza)</p> 	<p><b>38</b> Fregadero (1 pieza)</p> 	<p><b>39</b> Soporte para caja de condimentos (1 pieza)</p> 
<p><b>Nº 10 CAJA</b> <i>Interior Nº 4 Caja</i></p>	<p><b>40</b> Tiradores de cajón (2 piezas)</p> 	<p><b>41</b> Tirador de puerta (1 pieza)</p> 	<p><b>42</b> Base de grifo (1 pieza)</p> 	<p><b>43</b> Placa frontal del cajón inferior (1 pieza)</p> 	<p><b>44</b> Tubo de agua de plástico (1 pieza)</p> 
<p><b>45</b> Anillo de silicona hembra (1 pieza)</p> 	<p><b>46</b> Anillo de silicona macho (1 pieza)</p> 	<p><b>47</b> Grifo (1 pieza)</p> 	<p><b>48</b> Ganchos de metal (4 piezas)</p> 	<p><b>49</b> Tuerca de grifo (1 pieza)</p> 	
<p><b>Nº 5 CAJA</b></p>	<p><b>50</b> Cajón superior (1 pieza)</p> 	<p><b>51</b> Cajas de condimentos (4 piezas)</p> 	<p><b>52</b> Tapas de caja de condimentos (4 piezas)</p> 	<p><b>53</b> Cajones pequeños (2 piezas)</p> 	
<p><b>Nº 11 CAJA</b></p>	<p><b>54</b> Conjunto de botón LED (1 pieza)</p> 	<p><b>55</b> Tira de LED y paquete de batería (1 pieza)</p> 			



**56** Paquete de hardware (1 pieza)

- a.** Tornillos M6x12  
(15 piezas) (17 piezas) (15 piezas)
- b.** Pernos escalonados M6x20 (12 piezas)
- c.** Clavijas para estantes (8 piezas)
- d.** Arandelas para estantes (8 piezas)
- e.** Arandelas (2 piezas)
- f.** Tuercas de brida M4 (2 piezas)
- g.** Tornillos de rosca (6 piezas)
- h.** Tornillos M4x10 (17 piezas) (16 piezas)

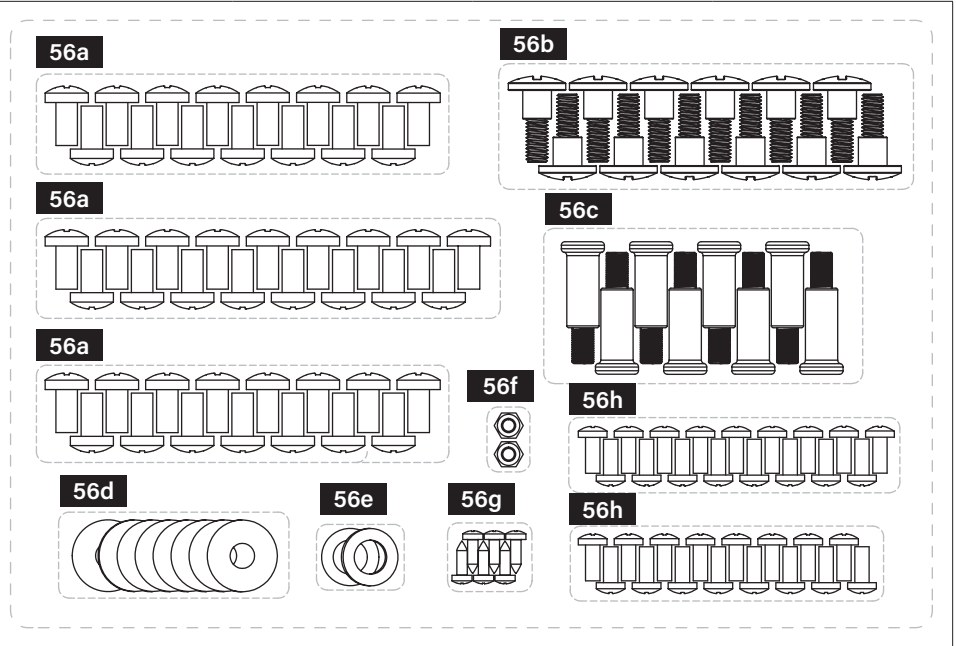

ESPAÑOL

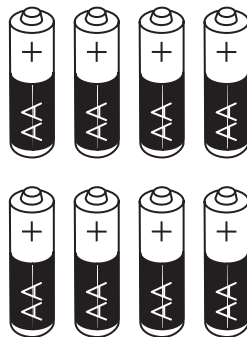
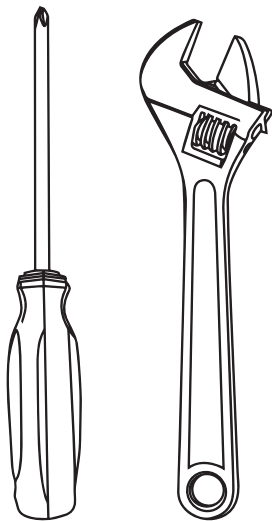

**HERRAMIENTAS NECESARIAS:**  
Destornillador Phillips y Llave ajustable

**NO INCLUIDO:**  
Ocho (8) pilas AA



## INSTRUCCIONES DE MONTAJE

Lea atentamente todas las instrucciones antes de continuar. Asegúrese de quitar todo el material de embalaje de plástico y cualquier protección de tránsito antes de ensamblar.

Encuentre un área grande y limpia para ensamblar su unidad. Consulte la lista de piezas y los diagramas de ensamblaje según sea necesario.

**PASO 01** Retire el conjunto de la pata de la articulación del embalaje. Afloje los cuatro (4) tornillos y separe los conjuntos de patas izquierda y derecha.

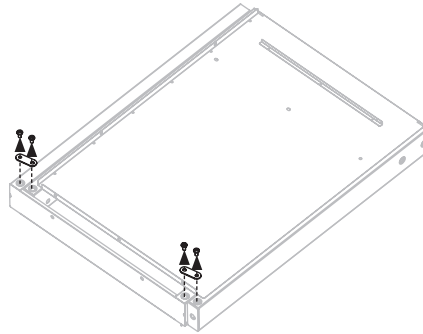

**PASO 02** Utilice tres (3) tornillos M4x10 (h.) para instalar el conjunto de la pata izquierda en el panel inferior.

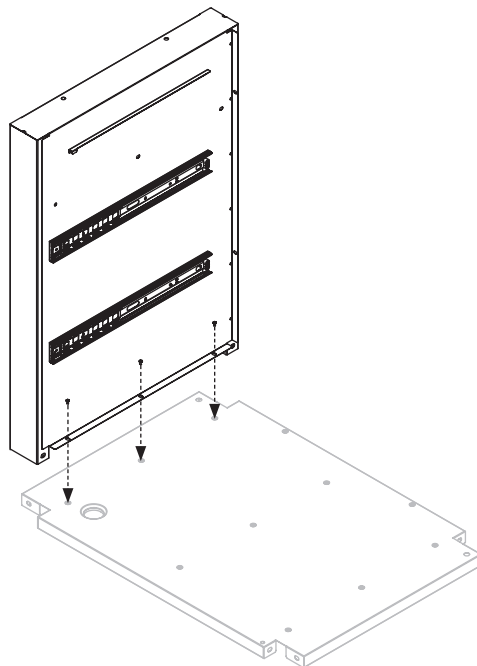

### ⚠ ADVERTENCIA

El fabricante ha hecho todo lo posible para eliminar los bordes afilados. Sin embargo, debe manejar todos los componentes con cuidado para evitar lesiones accidentales.

Algunas partes pueden contener bordes afilados, especialmente como se indica en estas instrucciones. Use guantes de protección si es necesario.

### ⚠ ADVERTENCIA

El uso de alcohol, medicamentos recetados o sin receta puede afectar la capacidad del consumidor para ensamblar u operar el aparato de manera segura.

### ⚠ PRECAUCIÓN

Se recomiendan dos personas para el montaje de este producto.



**PASO 03** Utilice tres (3) tornillos M4x10 (**h.**) para instalar el conjunto de la pata derecha en el panel inferior.

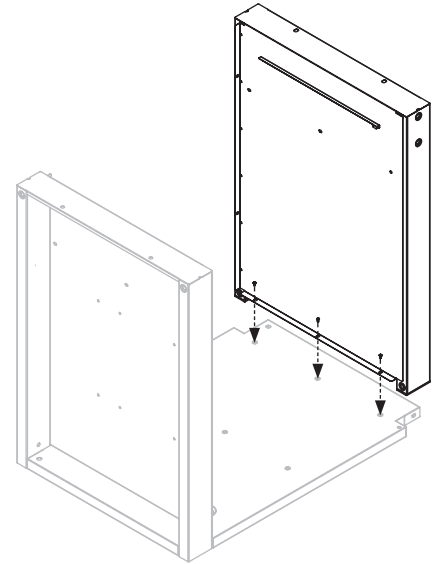

**PASO 04** Con la ayuda de otra persona, coloque el carro sobre su parte trasera. Utilice cuatro (4) tornillos M6x12 (**a.**) para sujetar las dos (2) ruedas fijas al conjunto de la pata izquierda. Utilice cuatro (4) tornillos M6x12 (**a.**) para asegurar el conjunto de la pata derecha al panel inferior, luego inserte las ruedas giratorias en el conjunto de la pata derecha.

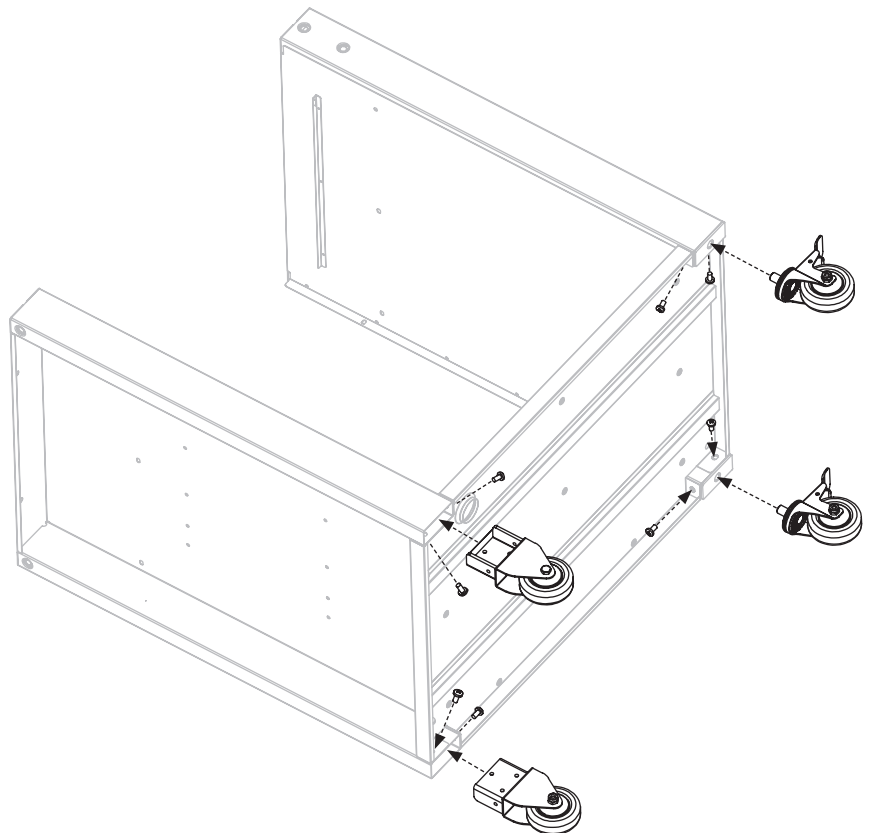



**PASO 05** Con la ayuda de otra persona, coloque el carro sobre sus pies y use dos (2) tornillos M6x12 (**a.**) para asegurar las ruedas fijas.

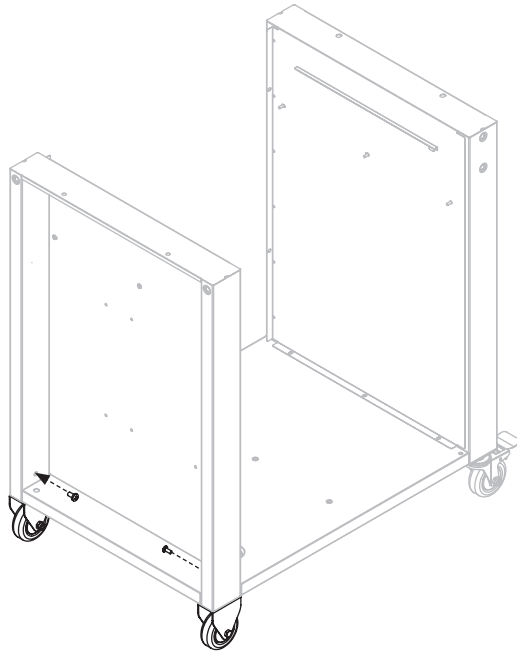

**PASO 06** Utilice tres (3) tornillos M4x10 (**h.**) para fijar el panel trasero derecho al ensamblaje de la pata derecha y al panel inferior.

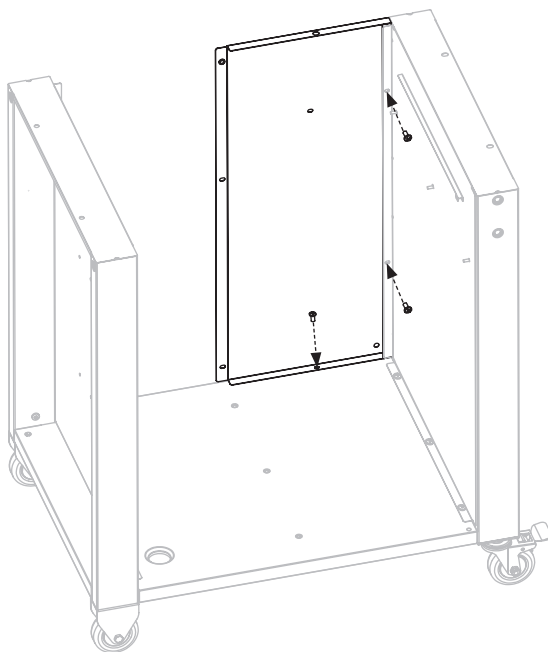



**PASO 07** Utilice tres (3) tornillos M4x10 (**h.**) para fijar el panel trasero izquierdo al ensamblaje de la pata izquierda y al panel inferior. Utilice un (1) tornillo M4x10 (**h.**) para asegurar el panel trasero izquierdo al panel trasero derecho.

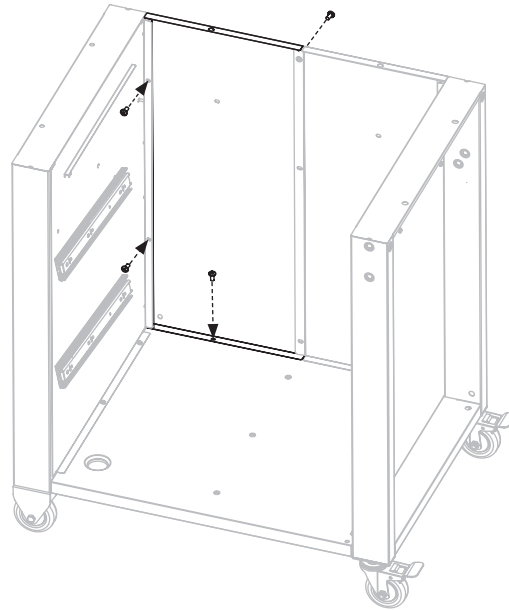

**PASO 08** Con la ayuda de otra persona, coloque el tablero de la mesa en el carrito. Utilice cuatro (4) tornillos M6x12 (**a.**) para asegurar la mesa a los conjuntos de patas izquierda y derecha (dos (2) por lado). Utilice dos (2) tornillos M6x12 (**a.**) para asegurar la mesa a los paneles traseros.

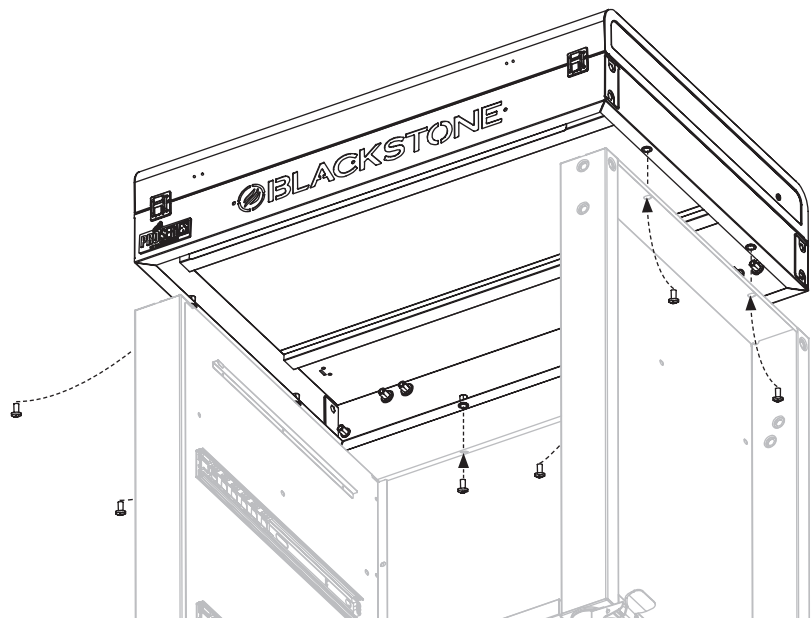



**PASO 09** Utilice tres (3) tornillos M4x10 (**h.**) para fijar el panel del cajón central al panel inferior.

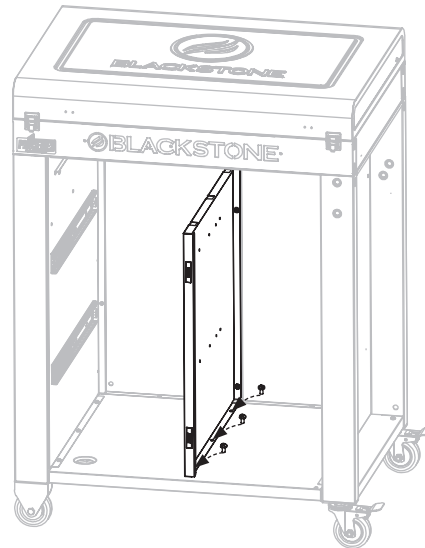

Utilice dos (2) tornillos M4x10 (**h.**) para asegurar el panel del cajón central a los paneles traseros.

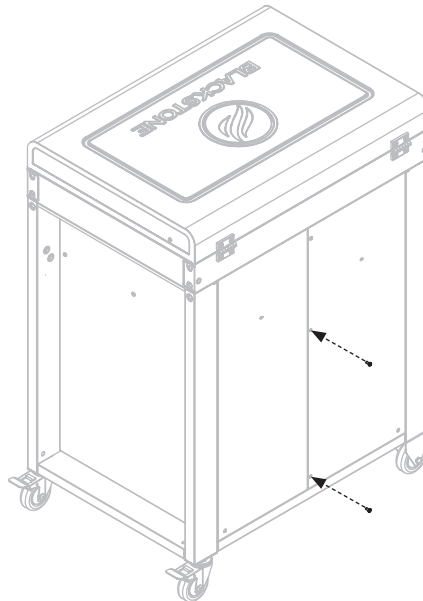

**PASO 10** Utilice seis (6) tornillos de rosca M3 para fijar las tres (3) tablas espaciadoras (**g.**) al panel del cajón superior.

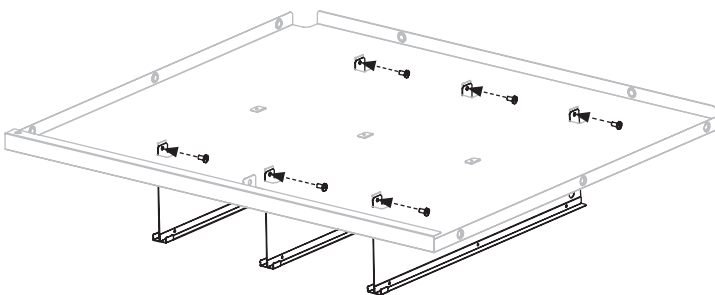



**PASO 11** Alinee la tabla espaciadora central para que se inserte en las ranuras superiores del panel del cajón central. Utilice seis (6) tornillos M4x10 (h.) para fijar el panel del cajón superior a los ensamblajes de las patas y un (1) tornillo M4x10 para asegurar el panel del cajón superior al panel del cajón medio.

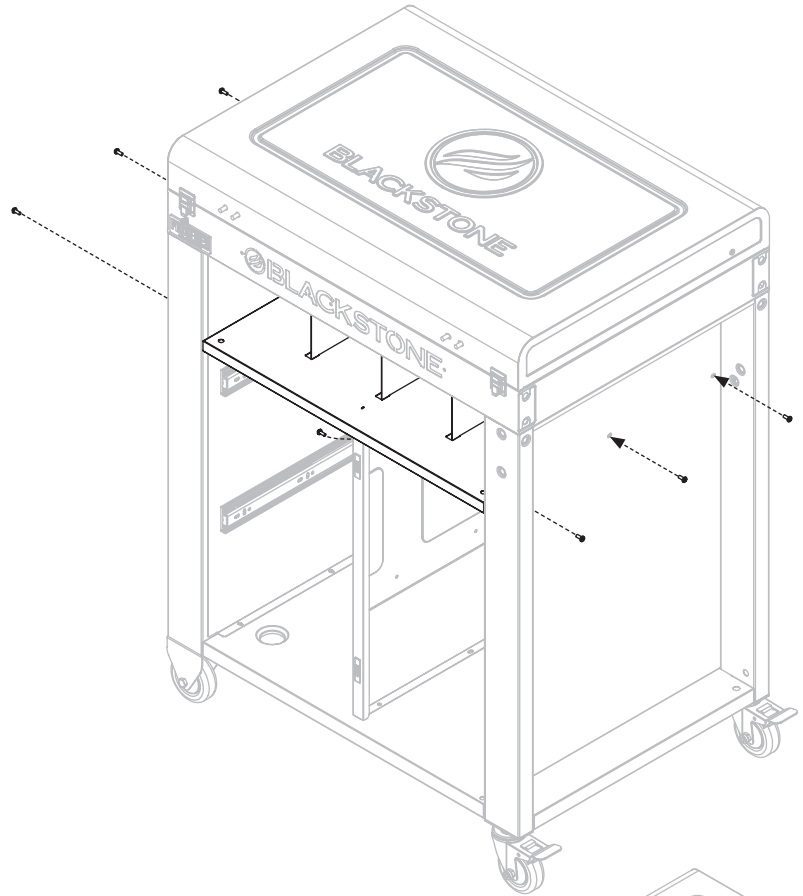

Utilice dos (2) tornillos M4x10 (h.) para asegurar el panel del cajón superior a los paneles traseros.

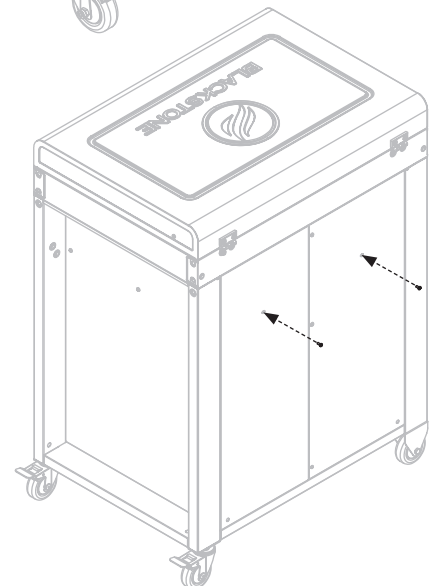





**PASO 12** Utilice dos (2) tornillos M6x12 (**a.**) para fijar una (1) manija de puerta a la puerta derecha del carrito.

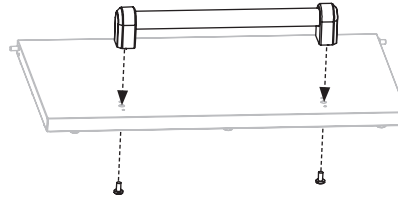

**PASO 13** Conecte la puerta derecha del carrito al carrito primero **1** insertando el pasador de la bisagra de la puerta inferior, luego **2** insertando el pasador de la bisagra de la puerta superior.

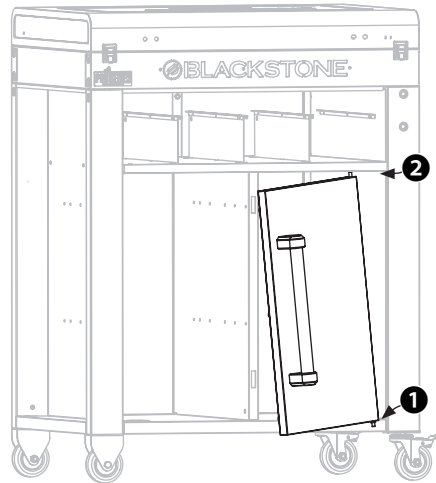

**PASO 14** Utilice dos (2) tornillos M6x12 (**a.**) para fijar una (1) manija del cajón a la placa frontal del cajón inferior.

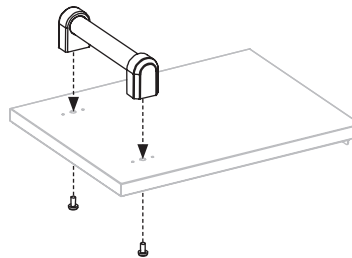

Utilice cuatro (4) tornillos M4x10 (**h.**) para fijar la placa frontal del cajón inferior al cajón inferior.

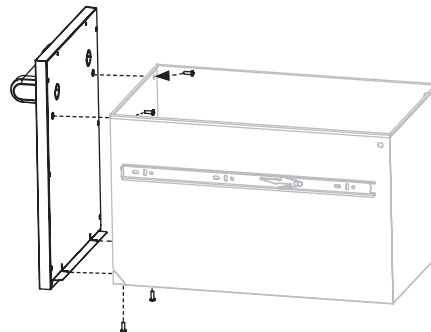



**PASO 15** Inserte el tapón en el orificio precortado del cajón inferior.

Extraiga el riel inferior del cajón.

Alinee el riel del cajón entre el cajón inferior y el carro, y deslice el cajón inferior en su lugar.

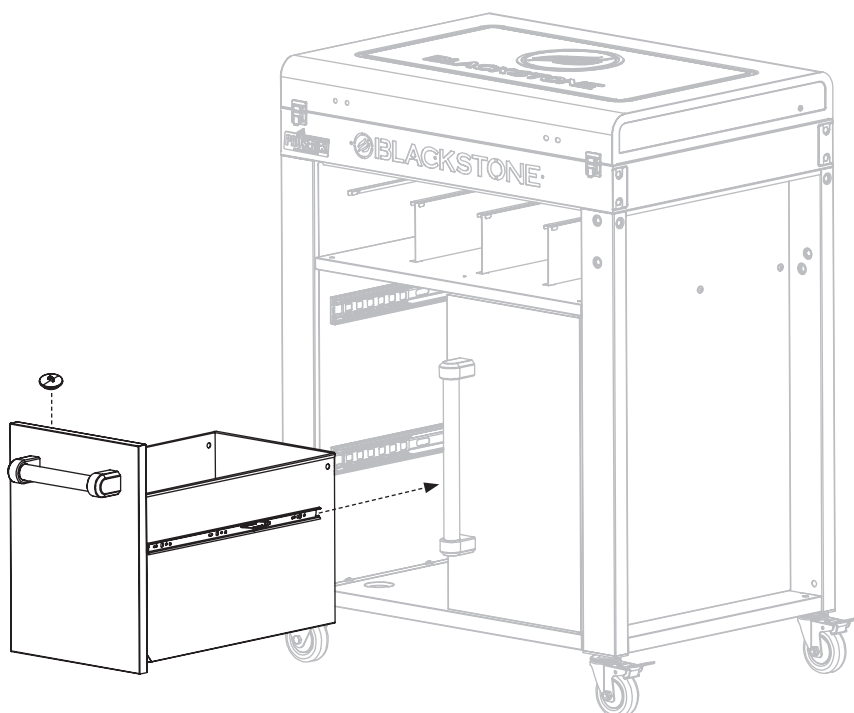

**PASO 16** Utilice dos (2) tornillos M6x12 (a.) para fijar una (1) manija de cajón al cajón superior.

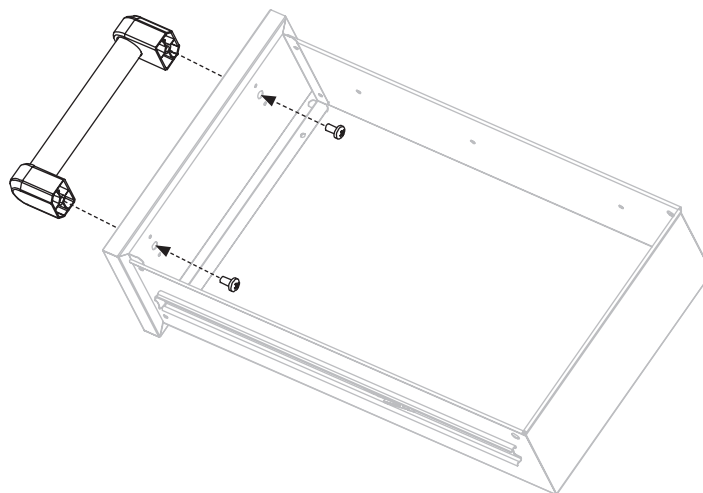



**PASO 17** Extraiga el riel superior del cajón.

Alinee el riel del cajón entre el cajón superior y el carro, y deslice el cajón superior en su lugar.

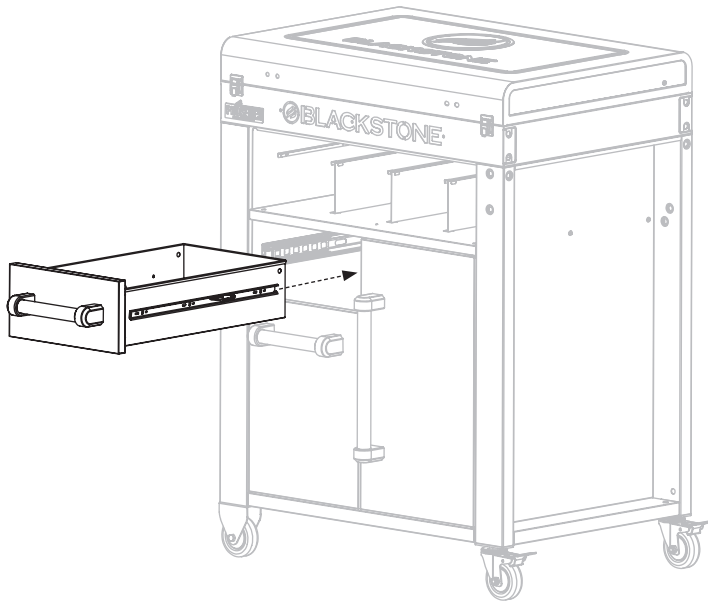

**PASO 18** Incline los cuatro (4) cajones pequeños y deslícelos en su lugar.

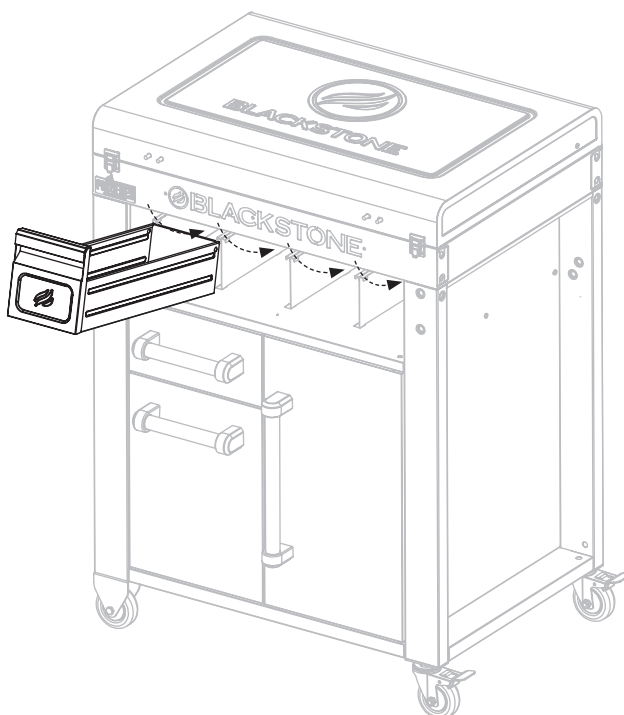



**PASO 19** Utilice dos (2) tornillos M6x12 (**a.**) para sujetar el soporte de toallas de papel al lado izquierdo del carro.

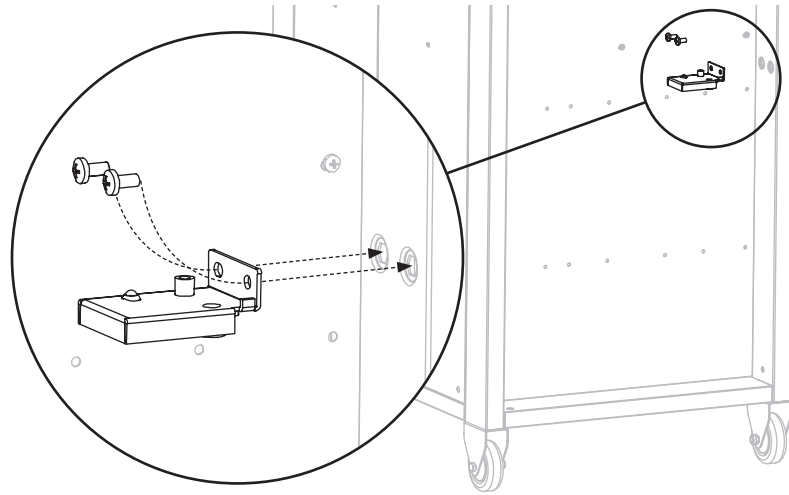

**PASO 20** Utilice un (1) tornillo M6x12 (**a.**) y dos (2) arandelas (**e.**) para sujetar el soporte de la torre de papel al soporte de la toalla de papel.

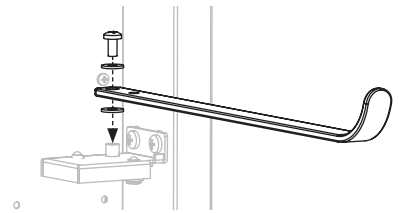

**PASO 21** Atornille dos (2) pernos escalonados M6x20 (**b.**) en los orificios inferiores del conjunto de la pata derecha.

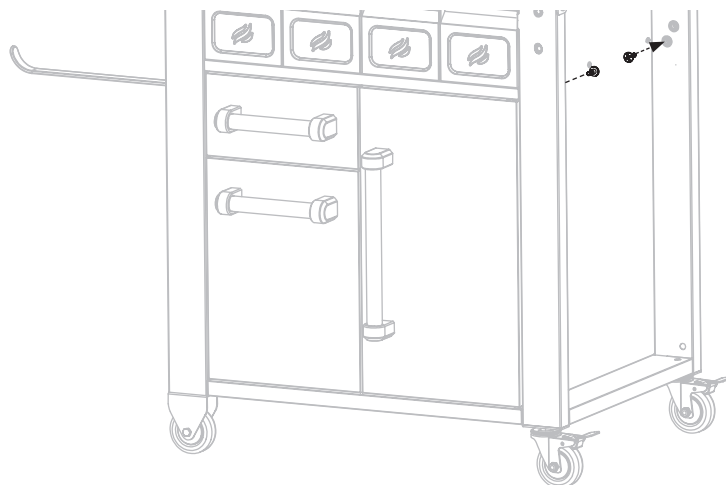



**PASO 22** Use dos (2) pernos escalonados M6x20 (b.) para sujetar el soporte de la bolsa de basura al ensamblaje de la pata derecha.

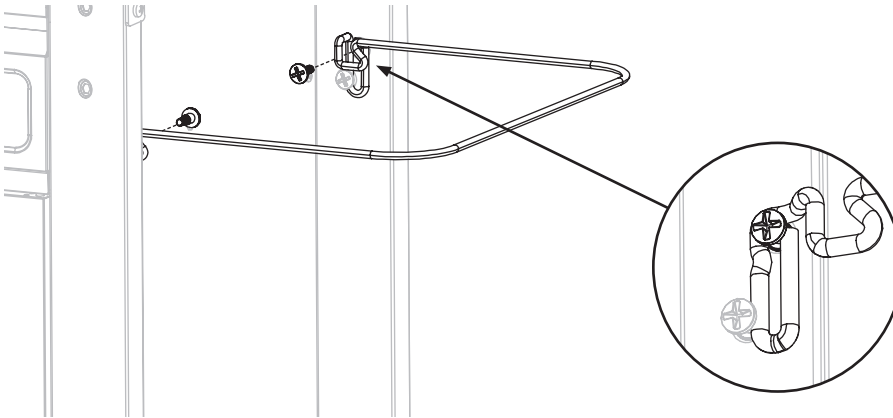

**PASO 23** Utilice siete (7) tornillos M6x12 (a.) para fijar dos (2) soportes del estante del lado derecho al lado derecho del carrito.

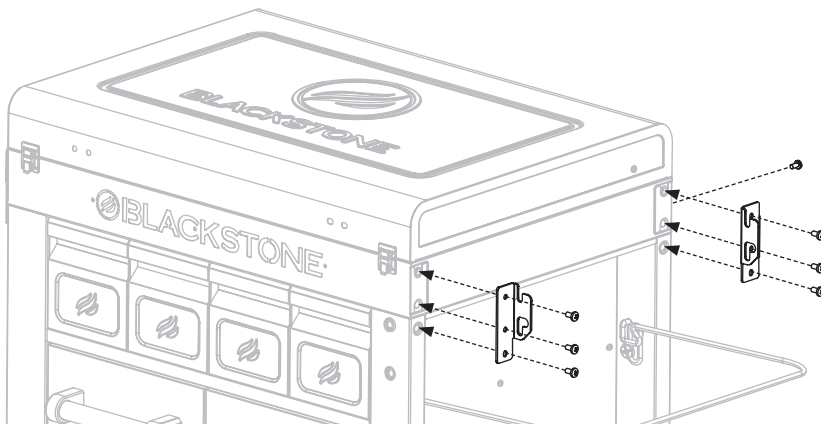

**PASO 24** Utilice siete (7) tornillos M6x12 (a.) para fijar dos (2) soportes del estante del lado izquierdo al lado izquierdo del carro.

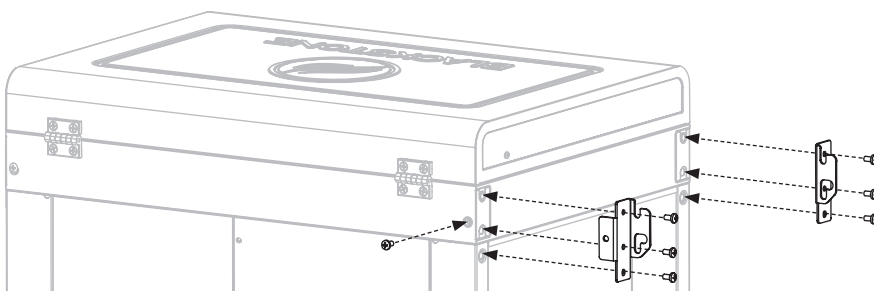



**PRECAUCIÓN**

El peso máximo en el estante lateral es de 4.5 kg (10 libras).

**PASO 25** Enrosque dos (2) pernos escalonados M6x20 (**b.**) en los orificios superiores del estante lateral derecho.

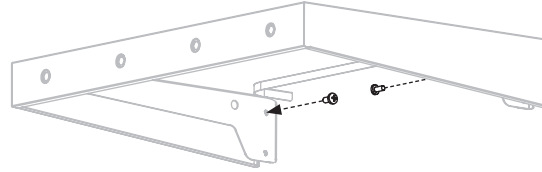

**PASO 26** Use dos (2) tornillos M6x12 (**a.**) para sujetar el panel de soporte del grifo al estante del lado izquierdo.

Enrosque dos (2) pernos escalonados M6x20 (**b.**) en los orificios superiores del estante lateral izquierdo.

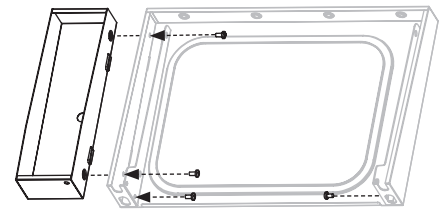

**PASO 27** Enganche los pernos del estante lateral derecho en los soportes del estante lateral. Enrosque dos (2) pernos escalonados M6x20 (**b.**) en los orificios inferiores de los soportes para asegurar el estante del lado derecho a los soportes del estante.

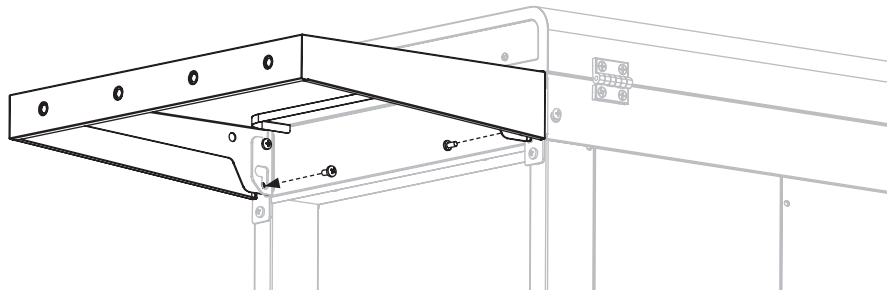

**PASO 28** Enganche los pernos del estante lateral izquierdo en los soportes del estante lateral. Enrosque dos (2) pernos escalonados M6x20 (**b.**) en los orificios inferiores de los soportes para asegurar el estante del lado izquierdo a los soportes del estante.

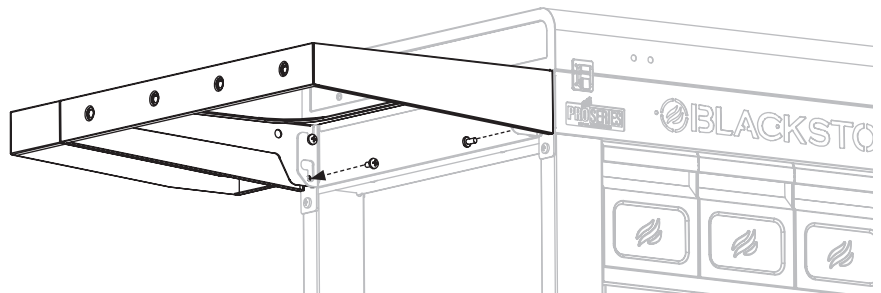



**PASO 29** Fije las cuatro (4) clavijas del estante lateral (**c.**) y las cuatro (4) arandelas de clavija (**d.**) a ambos estantes laterales atornillándolas en los orificios precortados.



**PASO 30** Instale la junta interior, la salida de agua interior, el filtro y la tapa del filtro en la parte inferior del fregadero.

Coloque la junta exterior contra la parte inferior del fregadero y atornille la salida de agua exterior en la salida de agua interior.

Utilice la tuerca de plástico para conectar el tubo de agua de plástico a la salida de agua exterior.

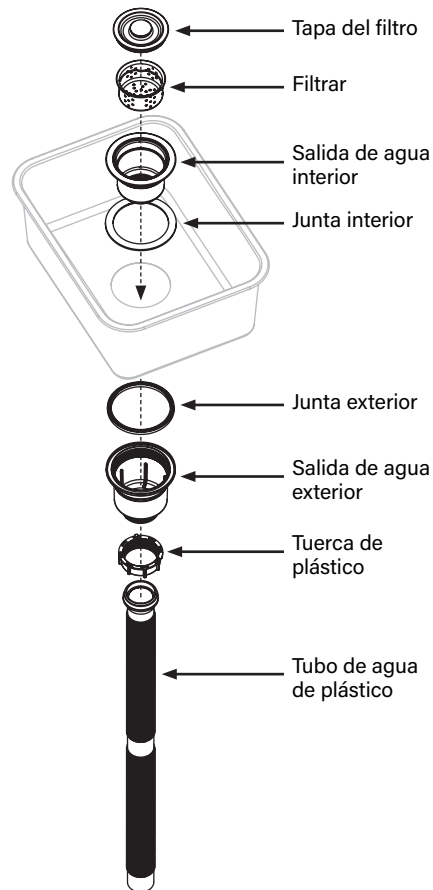



**PASO 31** Coloque el fregadero en el estante del lado izquierdo.  
(Dirija el tubo de agua de plástico a un balde u otro receptáculo).

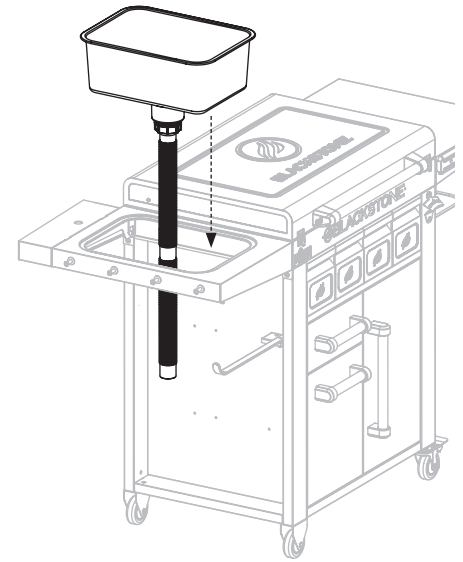

**PASO 32** Utilice dos (2) tornillos M6x12 (a.) para sujetar el abridor de botellas al frente del conjunto de la pata derecha.

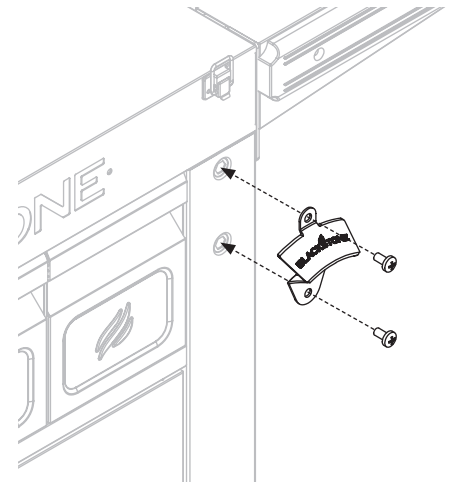

**PASO 33** Coloque la base del grifo y el anillo de silicona hembra en la parte inferior del grifo.

Coloque la base del grifo y el anillo de silicona hembra en la parte inferior del grifo.

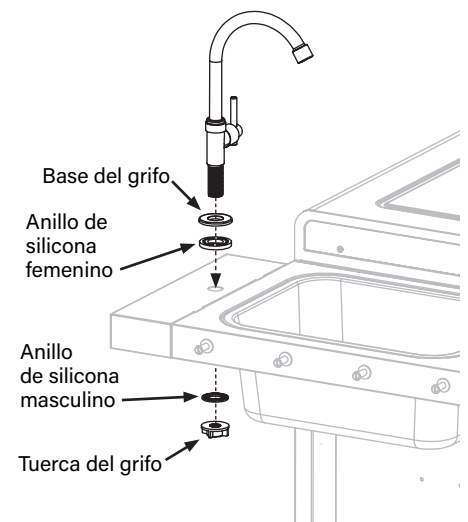





**PASO 34** Conecte la manguera del grifo al grifo. Ahora se puede conectar una manguera de jardín estándar (no incluida) a la manguera del grifo.

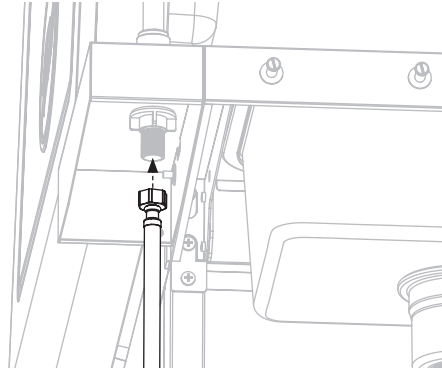

### ⚠ ADVERTENCIA

- No mezcle pilas nuevas y viejas.
- No mezcle pilas alcalinas, estándar (carbono-zinc) o recargables (ni-cad, ni-mh, etc.).

**PASO 35** Desde la parte inferior de la tapa, retire los seis (6) tornillos M4x10 del soporte del LED y de la tapa del paquete de baterías.

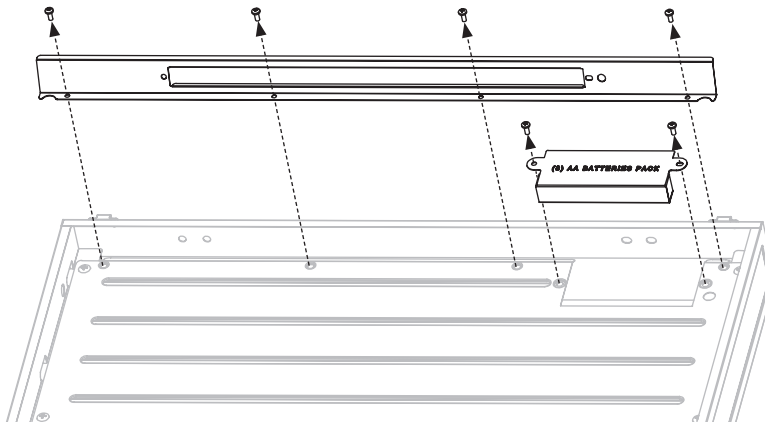

**PASO 36** Inserte ocho (8) baterías AA (no incluidas) en el paquete de baterías.

Coloque la batería en la tapa de la batería.

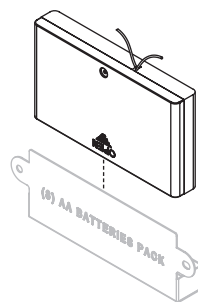

**PASO 37** Utilice dos (2) tornillos M4x10 (**h.**) y dos (2) tuercas M4 (**h.**) para fijar la tira de LED al soporte de LED.

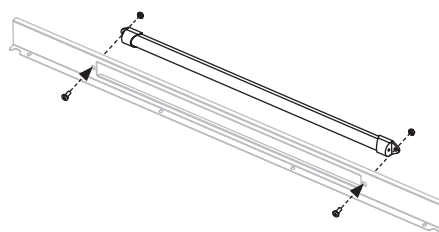



**PASO 38** Pase el conjunto del botón LED a través del orificio en la parte inferior de la tapa y conéctelo al terminal del paquete de baterías.

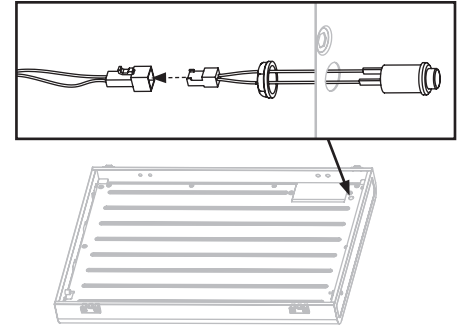

**PASO 39** Utilice cuatro (4) tornillos M6x12 (a.) para sujetar el asa de la tapa a la tapa.

Vuelva a colocar la tapa del paquete de baterías con el paquete de baterías debajo. Vuelva a colocar el soporte de LED.

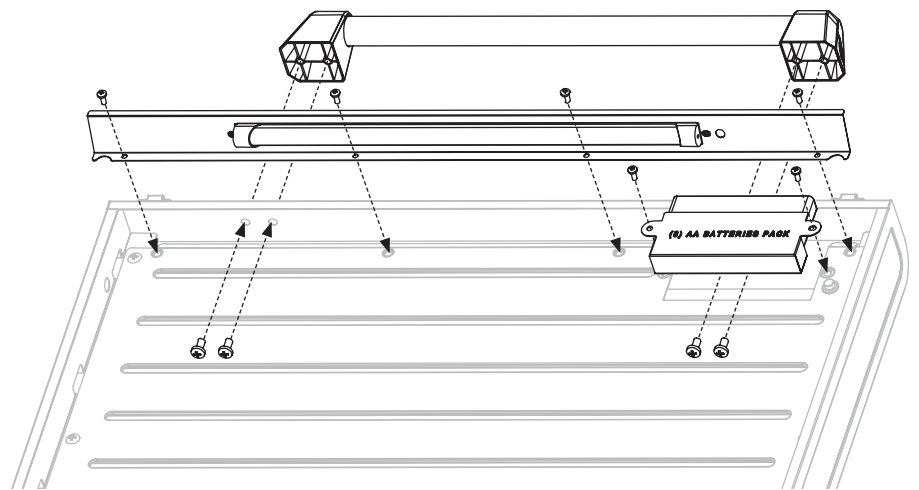

**PASO 40** Cuelgue las ocho (8) cajas de condimentos y los cuatro (4) ganchos de metal en las ranuras dentro de la tapa.

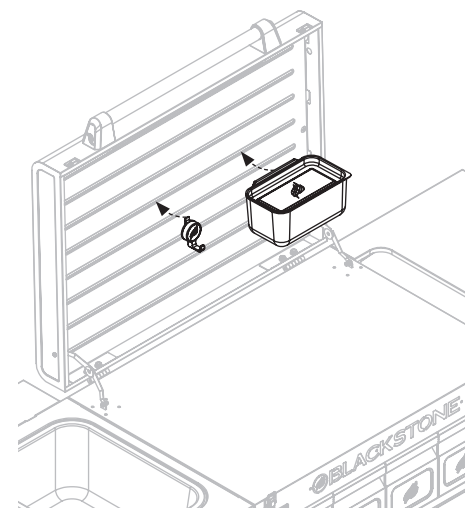



**PASO 41** ¡Disfruta cocinando al aire libre con tu Carrito de preparación para servicio y tienda Blackstone!

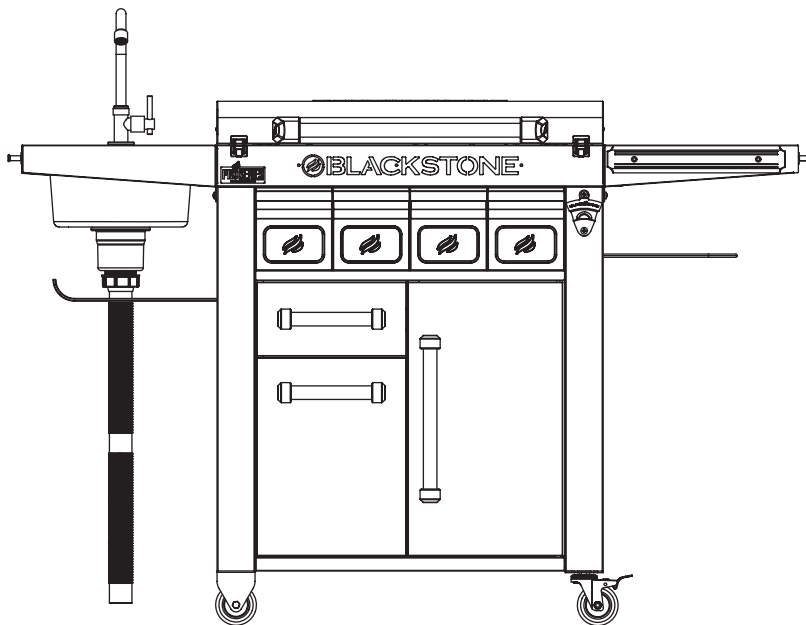

Cuando no esté en uso: Gire el soporte de la torre de papel.

Retire el grifo y el fregadero antes de levantar y bajar el estante del lado derecho.

Levante y baje el soporte de la bolsa de basura.

Levante y baje el estante del lado izquierdo.

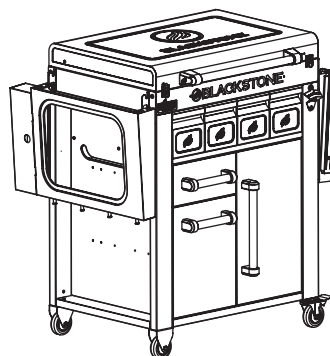
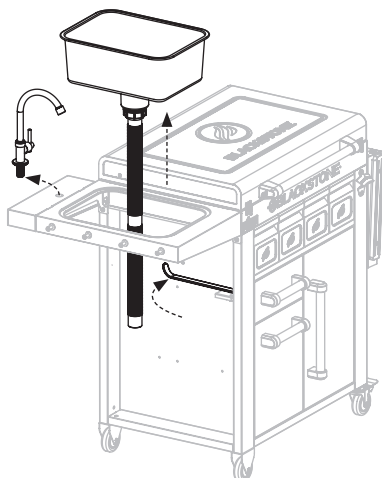

**VÍDEOS DE MONTAJE**

Vea videos de soporte técnico y ensamblaje de productos en línea en [blackstoneproducts.com/support](https://blackstoneproducts.com/support) y en YouTube @BlackstoneGriddles



