

Model 1938

SERVE & STORE PREP CART

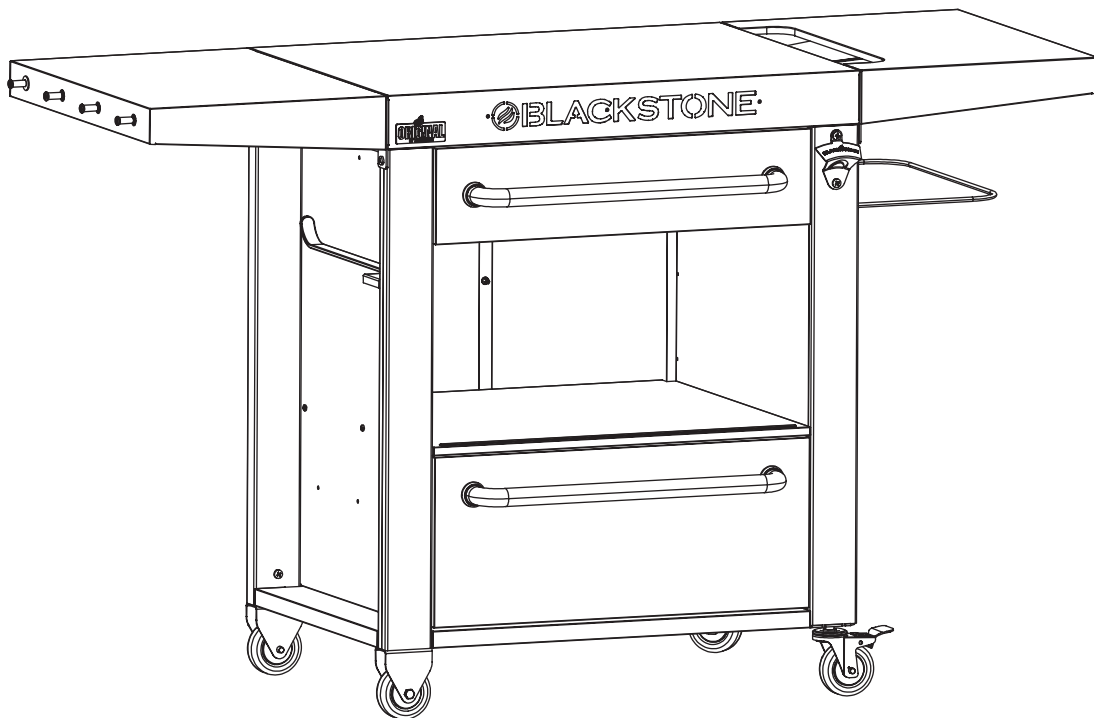

Please reference blackstoneproducts.com/support for the latest version of this manual, and to follow along with assembly videos.



TABLE OF CONTENTS

It is the consumer's responsibility to see that the unit is properly assembled, installed, and maintained. Failure to follow the instructions in this manual could result in bodily injury and/or property damage.

CONTENTS

01. WARRANTY.....	01
02. ASSEMBLY GUIDE	02

SAFETY ALERT KEY

Read and follow all the notices throughout the manual.

DANGER

Indicates an imminently hazardous situation which, if not avoided, may result in death or serious injury.

WARNING

Indicates the possibility of serious bodily injury if the instructions are not followed.

CAUTION

Indicates a potentially hazardous situation which, if not avoided, may result in minor or moderate injury.



NORTH ATLANTIC IMPORTS LLC 1-YEAR WARRANTY

North Atlantic Imports, the manufacturer, will warranty for one year from purchase all parts, workmanship, and finishes. It will be the manufacturer's option as to whether to repair or replace any of the above items. All warranties are limited to the original purchaser only. This warranty does not cover any liability on the part of North Atlantic Imports, its agents or employees, for any indirect or consequential damages for breach of warranty. The purchaser must follow the manufacturer's usage instructions.

Under no circumstances is the manufacturer responsible for damages from the failure to operate the cooking station properly. It is the responsibility of the purchaser to establish the warranty period by verifying the original purchase date with original sales receipt.

For more detailed explanation of the warranty, read below:

North Atlantic Imports LLC warrants to the owner that the product covered by this agreement is free from defects in material and workmanship under normal use and service for which it was intended if, but only if, it has been operated in accordance with North Atlantic Imports LLC instructions exclusively for domestic use, and not for private or public club, institutional or commercial purposes.

North Atlantic Imports LLC's obligation under this warranty is limited to replacing or repairing, free of charge, any part or parts that may prove, to the satisfaction of North Atlantic Imports LLC, to be defective under normal home use and service within the following stated periods of time from the date of purchase; for one year from purchase, all parts, finish, and workmanship. Should any failure to conform to this warranty become apparent during applicable warranty periods stated above, the original purchaser must notify North Atlantic Imports LLC

of breach of warranty within the applicable warranty period.

North Atlantic Imports LLC shall upon notice and compliance by the original purchaser with such instructions, correct such nonconformity by repair or replacement of the defective part or parts. Correction in the manner provided above shall constitute a fulfillment of all obligations of North Atlantic Imports LLC with respect to the quality of the product.

North Atlantic Imports LLC does not warrant this equipment to meet the requirement of any safety code of any state, municipality or other jurisdiction, and the original purchaser assumes all risk and liability whatsoever resulting from the use thereof, whether used in accordance with North Atlantic Imports LLC instructions or otherwise.

This warranty does not cover and is intended to exclude any liability on the part of North Atlantic its agents,

servants or employees whether under this warranty or implied by law for any indirect or consequential damages for breach on any warranty. The purchaser must establish all applicable warranty periods pursuant to this warranty by verifying the original purchase date by producing the dated sales receipt. This warranty shall not apply to this product or any other part thereof which has been subject to accident, negligence, alteration, abuse, or misuse or which has been repaired or altered without North Atlantic written consent, outside of North Atlantic Imports LLC factory.

North Atlantic Imports LLC makes no warranty whatsoever in respect to accessories or parts not supplied with it. This warranty shall apply only within the boundaries of the United States of America. This warranty gives the original purchaser specific rights, and the original purchaser may also have other rights, which vary from state to state.



ASSEMBLY GUIDE

ILLUSTRATED PARTS LIST

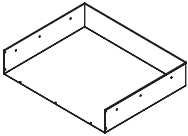
1 Table (1 piece) 		2 Left leg assembly (1 piece) 		3 Right leg assembly (1 piece) 	
4 Left rear panel (1 piece) 	5 Right rear panel (1 piece) 	6 Seasoning boxes (3 pieces) 	7 Seasoning box lids (3 pieces) 	8 Cart base (1 piece) 	
9 Left side shelf (1 piece) 	10 Right side shelf (1 piece) 	11 Inner shelf (1 piece) 	12 Paper towel holder (1 piece) 	13 Garbage bag holder (1 piece) 	14 Bottle opener (1 piece) 
15 Upper drawer (1 piece) 	16 Lower drawer (1 piece) 	17 Upper drawer face plate (1 piece) 	18 Lower drawer face plate (1 piece) 	19 Drawer handles (2 pieces) 	20 Plug (1 piece) 
21 Caster wheels (2 pieces) 	22 Fixed wheels (2 pieces) 	23 Left front side shelf bracket (1 piece) 	24 Right front side shelf bracket (1 piece) 	25 Left rear side shelf bracket (1 piece) 	26 Right rear side shelf bracket (1 piece) 



<p>27 Hardware pack (1 piece)</p> <p>a. Step 2, 3: M4x10 screws (6 pieces)</p> <p>b. Step 15, 7: M4x10 screws (14 pieces)</p> <p>c. Step 5, 6: M4x10 screws (9 pieces)</p> <p>d. Step 4: M6x12 screws (6 pieces)</p> <p>e. Step 14: M4x10 screws (7 pieces)</p> <p>f. Step 14: M4 nuts (7 pieces)</p> <p>g. Step 10, 11: Metal peg washers (8 pieces)</p> <p>h. Step 9: M6x12 screws (14 pieces)</p> <p>i. Step 12, 13, 19: M6 Step bolts (8 pieces)</p> <p>j. Step 10, 11: Shelf pegs (8 pieces)</p> <p>k. Step 8, 17, 18: M6x12 screws (10 pieces)</p> <p>l. Spares</p>	
--	--

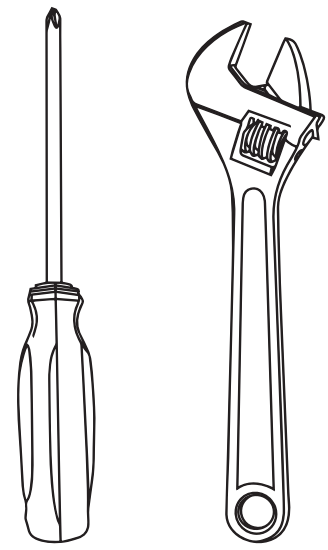

TOOLS NEEDED: Phillips head screwdriver & Adjustable wrench

**⚠ WARNING**

The manufacturer has made every effort to eliminate any sharp edges. However, you should handle all components with care to avoid accidental injury.

Some parts may contain sharp edges, especially as noted in these instructions. Wear protective gloves if necessary.

⚠ WARNING

The use of alcohol, prescription or non-prescription drugs may impair the consumer's ability to properly assemble or safely operate the appliance.

⚠ CAUTION

Two people are recommended for the assembly of this product.

ASSEMBLY INSTRUCTIONS

Please read all instructions thoroughly before proceeding. Make sure all the plastic packing material is removed before assembling.

Find a large, clean area to assemble your unit. Please refer to the parts list and assembly diagrams as necessary.

STEP 01 Remove the joint leg assembly from the packaging. Loosen the four (4) screws and separate the left and right leg assemblies.

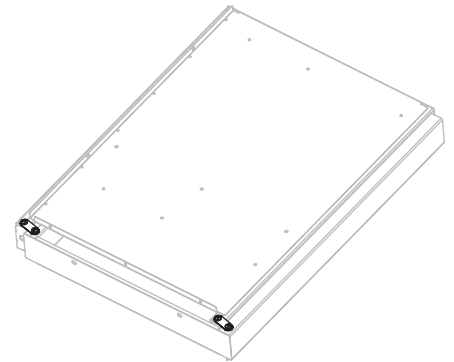

STEP 02 Use three (3) M4x10 screws to attach the left leg assembly to the cart base.

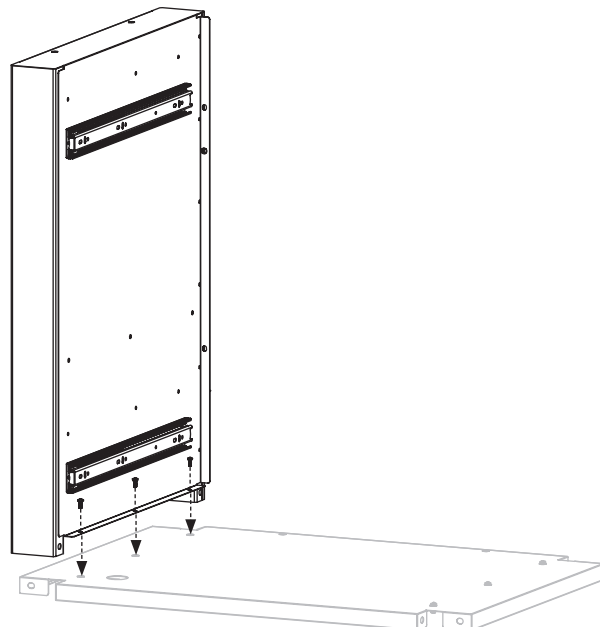



STEP 03 Use three (3) M4x10 screws to attach the right leg assembly to the cart base.

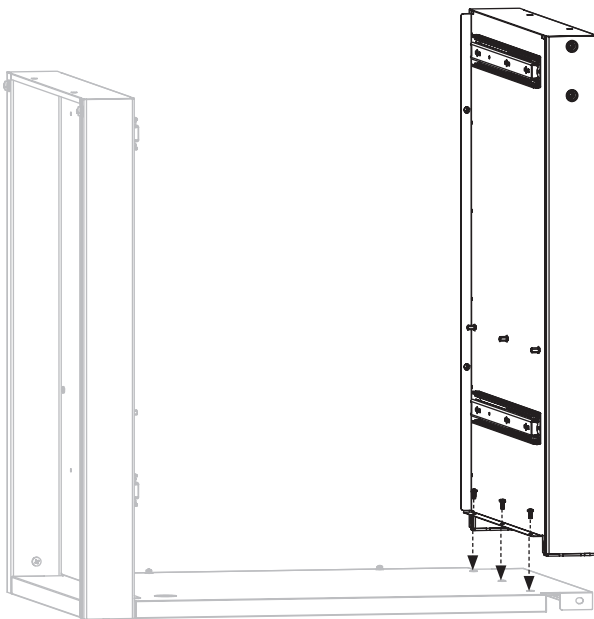

STEP 04 With the help of other person, flip the cart base upside down. Use six (6) M6x12 screws to attach the two (2) fixed wheels to the left leg assembly. Use four (4) M6x12 screws to attach the the two (2) caster wheels to the right leg assembly.

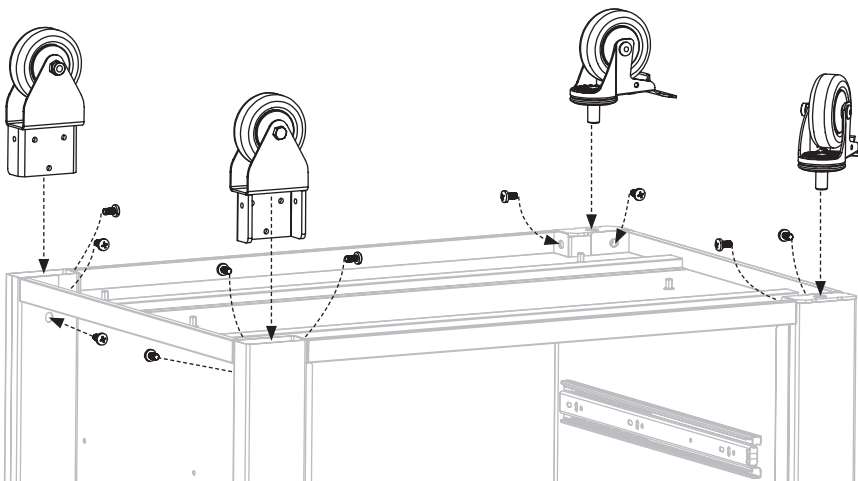
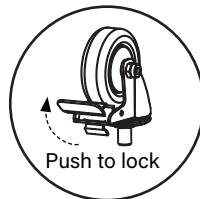



STEP 05 **With the help with other person,** set the cart upright on its wheels. Use two (2) M4x10 screws to fasten the right rear panel to the right leg assembly. Use one (1) M4x10 screw to fasten the right rear panel to the cart base.

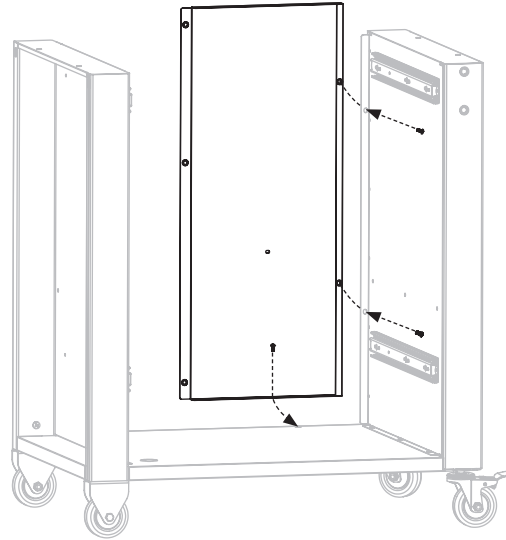

STEP 06 Use two (2) M4x10 screws to fasten the left rear panel to the left leg assembly. Use one (1) M4x10 screw to fasten the left rear panel to the cart base. From the back of the panel, use three (3) M4x10 screws to fasten the the left rear panel to the right rear panel.

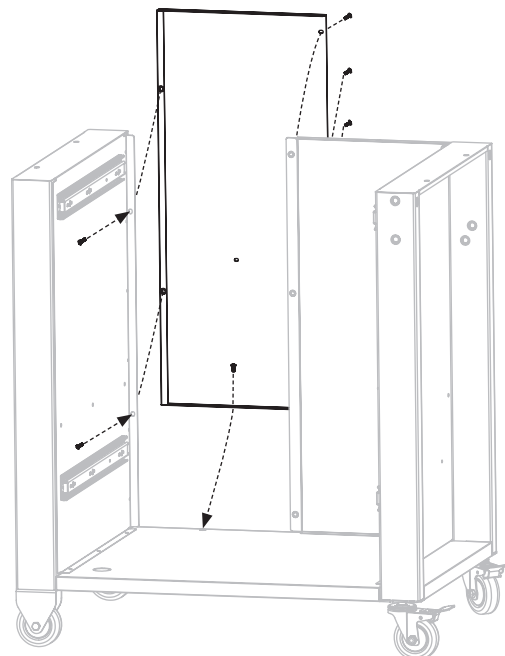



STEP 07 Use eight (8) M4x10 screws to install the inner shelf to the cart (three (3) screws on each leg assembly, one (1) on each back panel).

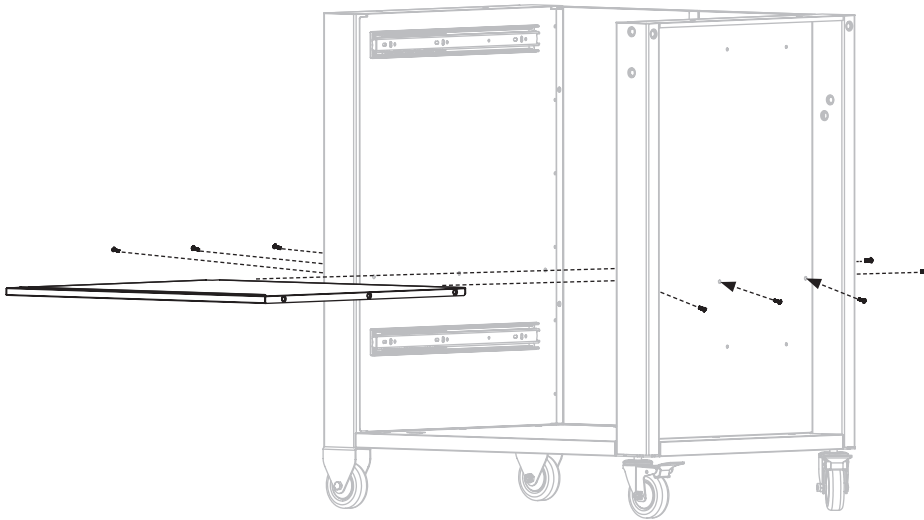

STEP 08 Place the table onto the stand and secure with six (6) M6x12 screws (two (2) screws on each leg assembly, one (1) on each back panel).

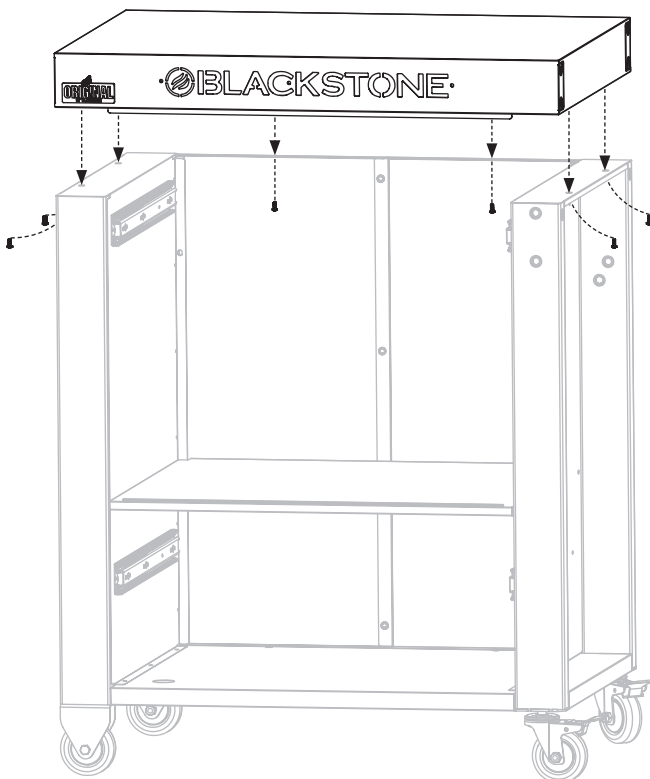



STEP 09 ① Use three (3) M6x12 screws to attach the left front side shelf bracket to the left side of the cart. ② Use four (4) M6x12 screws to attach the left rear side shelf bracket to the left side of the cart. ③ Use three (3) M6x12 screws to attach the right front side shelf bracket to the right side of the cart. ④ Use four (4) M6x12 screws to attach the right rear side shelf bracket to the right side of the cart.

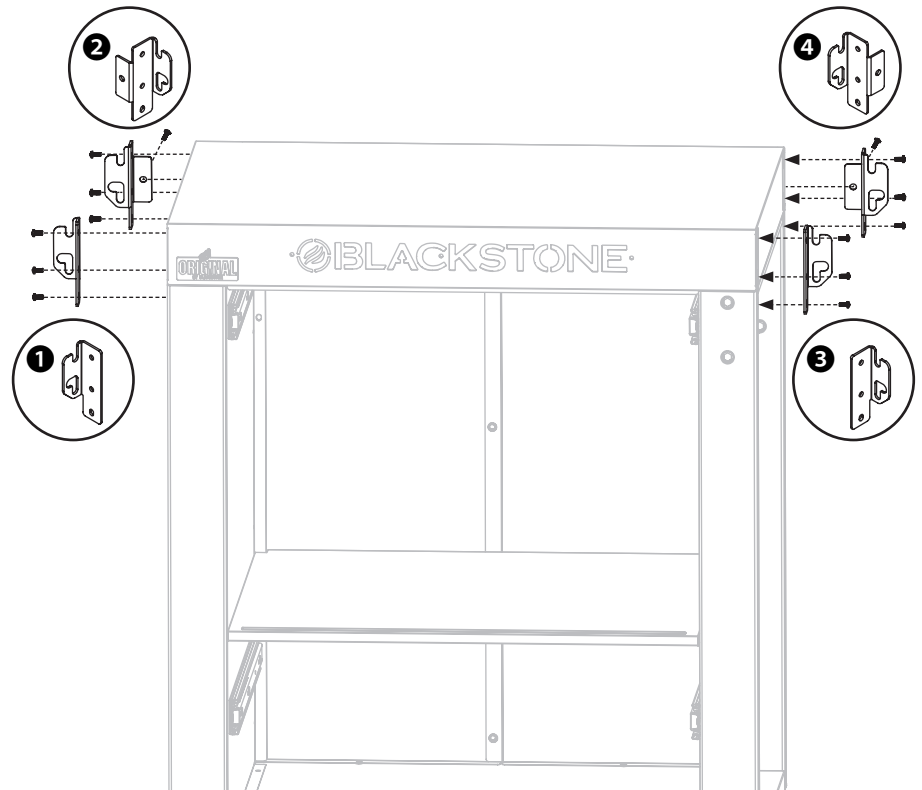

STEP 10 Thread four (4) side shelf pegs into four (4) peg washers and the precut holes of the left side shelf.

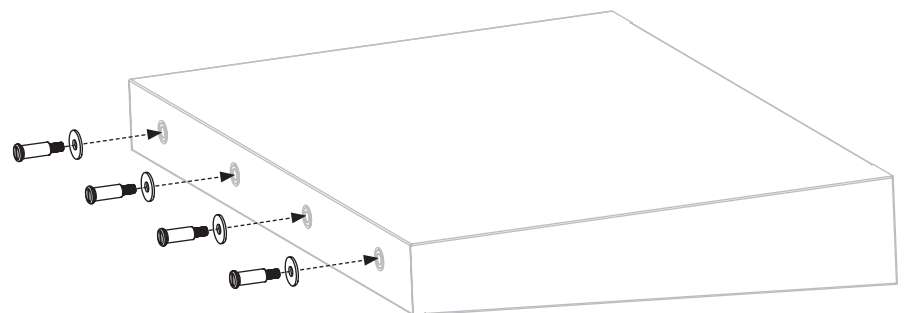



STEP 11 Thread four (4) side shelf pegs into four (4) peg washers and the precut holes of the right side shelf.

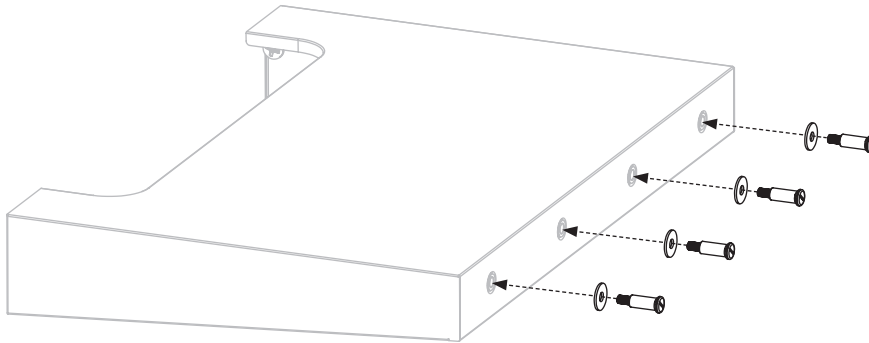

STEP 12 Hook the left side shelf on the shelf brackets, and use two (2) step bolts to secure through the lower holes.

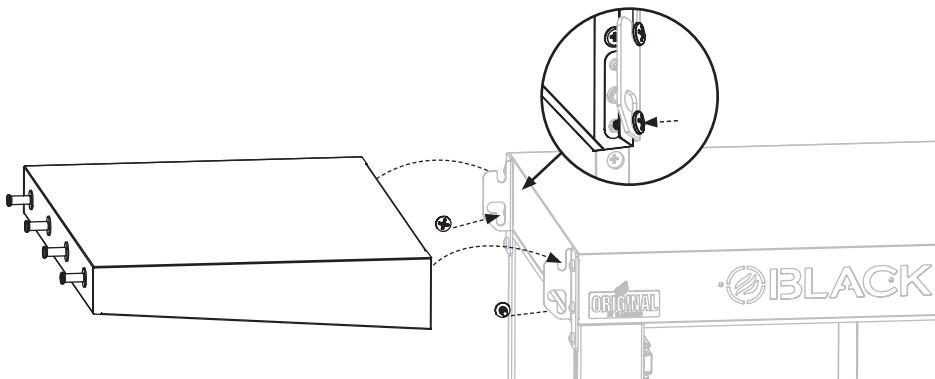

STEP 13 Hook the right side shelf on the shelf brackets, and use two (2) step bolts to secure through the lower holes.

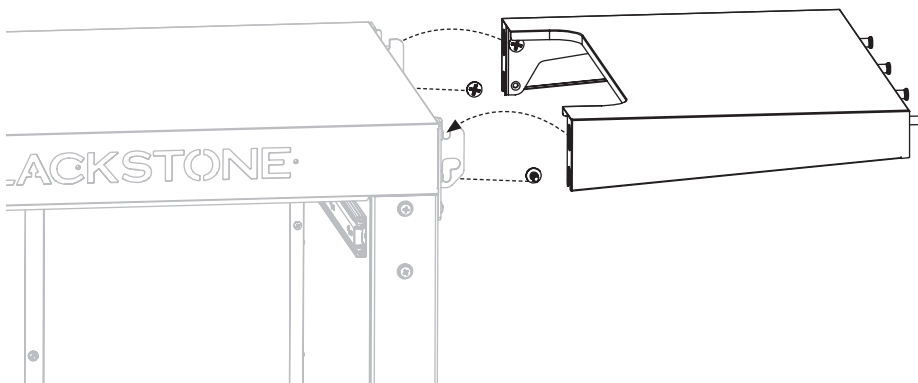



STEP 14 Use two (2) M6x12 screws to install one (1) drawer handle to the front plate of the upper drawer.

Use seven (7) M4x10 screws and seven (7) nuts to attach the front plate to the upper drawer.

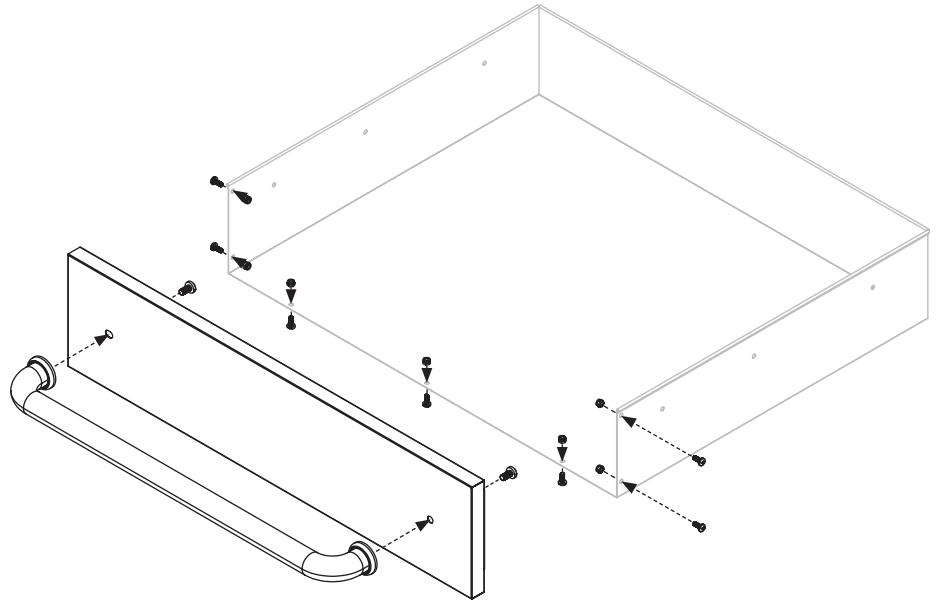

STEP 15 Use two (2) M6x12 screws to install one (1) drawer handle to the front plate of the lower drawer.

Use six (6) M4x10 screws to attach the front plate to the lower drawer.

Insert the plug in the pre-cut hole of the lower drawer. (The lower drawer can store ice and water.)

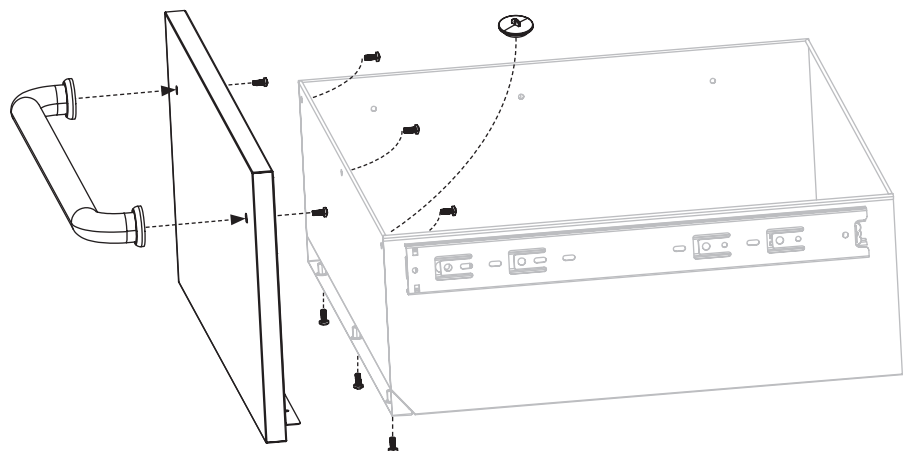



STEP 16 Align and insert the upper drawer and lower drawers into their respective slides.

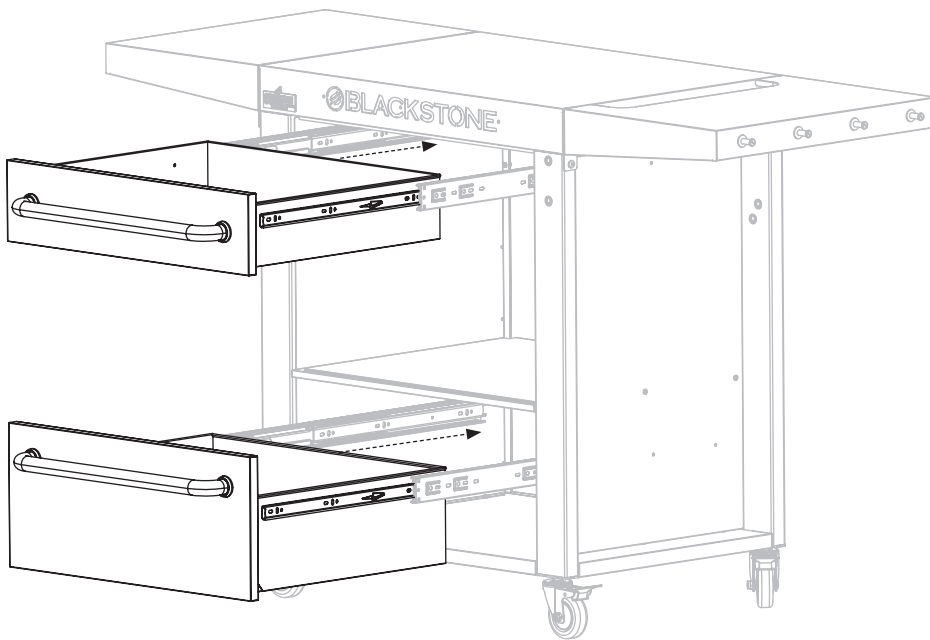

STEP 17 Loosen the paper towel holder arm screw and remove the paper towel holder arm, then use two (2) M6x12 screws to attach the paper towel holder to the left side of the unit. Reattach the paper towel holder arm.

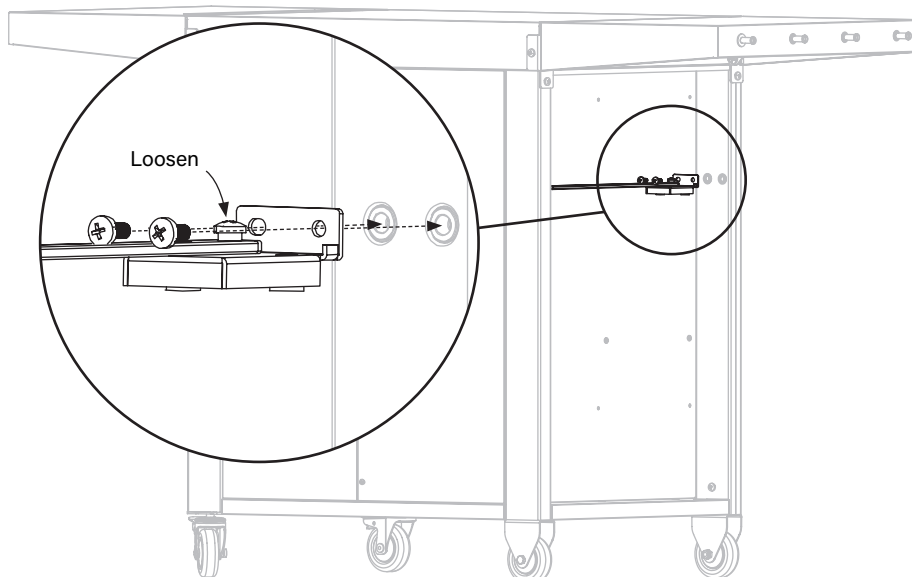



STEP 18 Use two (2) M6x12 screws to attach the bottle opener to the right leg assembly.



STEP 19 Screw in two (2) M4 step bolts into the lower holes of the right leg assembly. Then, align the loops of the garbage bag holder to the top holes on the right leg assembly and use two (2) M4 step bolts to secure.

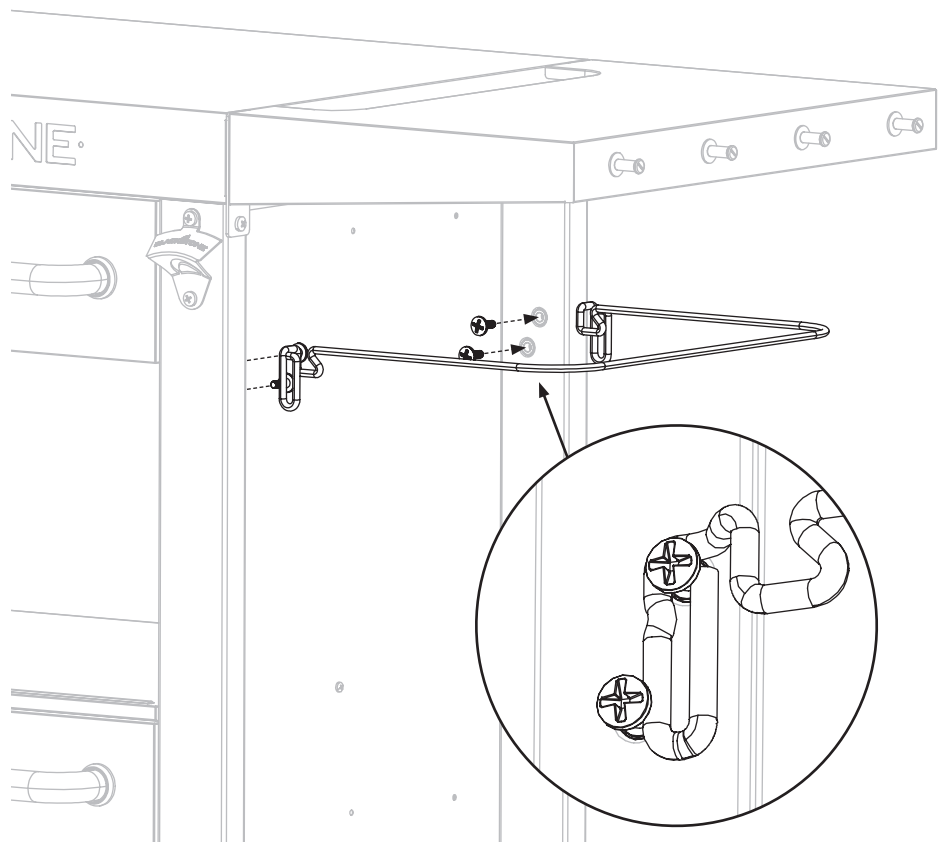



STEP 20 Enjoy cooking outdoors with your Blackstone Store & Serve Prep Cart!

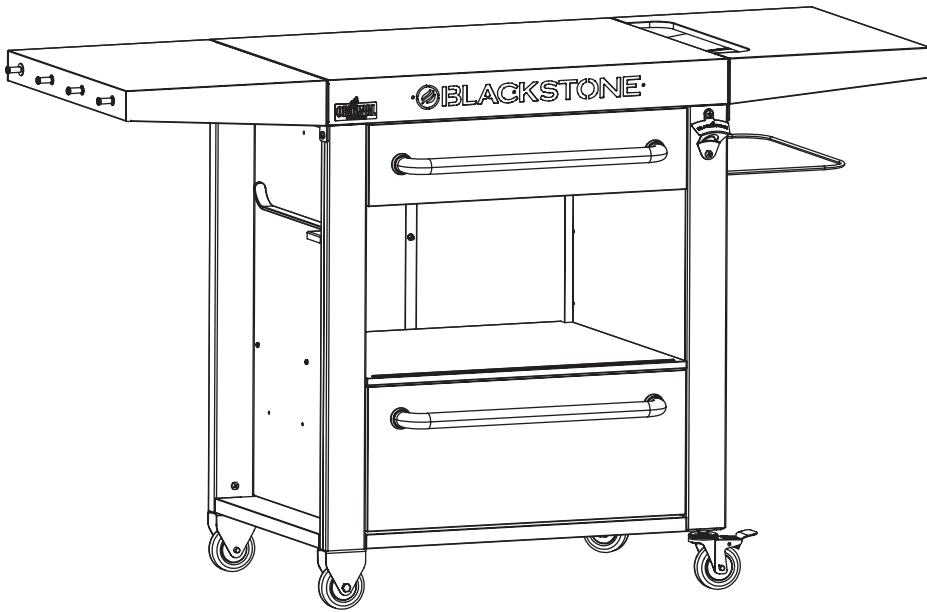

Store bay leaves, diced vegetables, spices and more in your seasoning boxes!

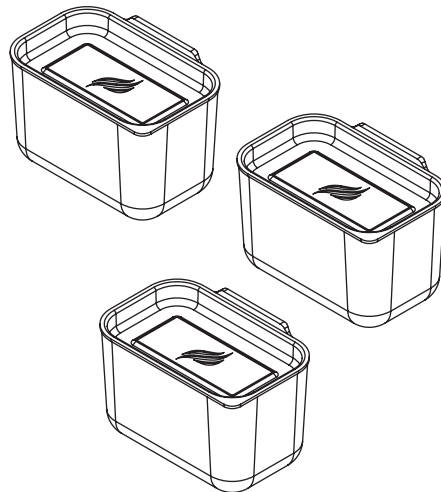

OUR CUSTOMER SERVICE STAFF IS HERE TO HELP YOU!

Register your Blackstone product at blackstoneproducts.com/register and visit us online at blackstoneproducts.com/support



We are pleased to help you with any questions concerning appliance use, replacement parts, or your warranty.

Customer Service Hours:
Monday - Friday
7:00 am - 5:00 pm
Mountain Standard Time

Modèle 1938

SERVIR ET STOCKER LE

CHARIOT DE PRÉPARATION

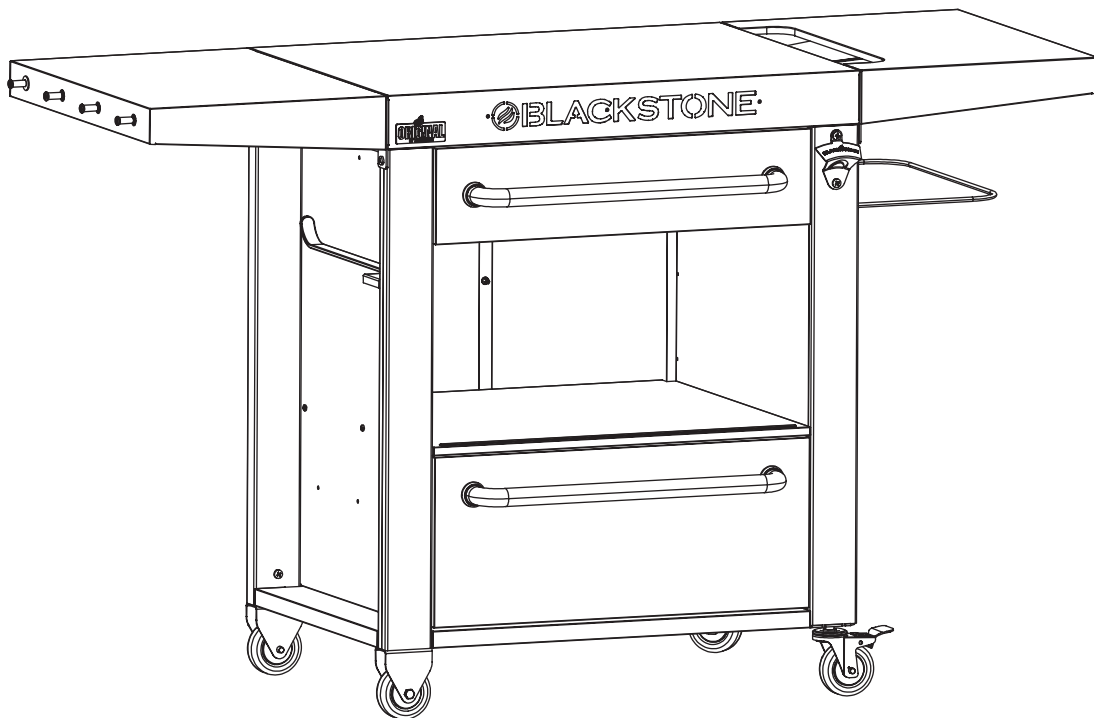

Veillez consulter blackstoneproducts.com/support pour obtenir la dernière version de ce manuel et suivre les vidéos d'assemblage.



TABLE DES MATIÈRES

Il incombe au consommateur de s'assurer que l'unité est correctement assemblée, installée et entretenue. Si vous ne suivez pas les instructions de ce manuel, vous risquez des blessures corporelles et/ou des dégâts matériels.

CONTENU

01. GARANTIE	01
02. GUIDE DE MONTAGE	02

MESSAGES RELATIFS À LA SÉCURITÉ

Lisez et suivez tous les avertissements qui se trouvent dans ce manuel.

DANGER

Indique une situation extrêmement dangereuse qui, si elle n'est pas évitée, peut entraîner des blessures graves, voire mortelles.

ATTENTION

Indique la possibilité de blessures corporelles graves si les instructions ne sont pas suivies.

MISE EN GARDE

Indique une situation potentiellement dangereuse qui, si elle n'est pas évitée, peut entraîner des blessures légères ou modérées.



GARANTIE D'UN AN DE NORTH ATLANTIC IMPORTS LLC

North Atlantic Imports, le fabricant, garantira toutes les pièces, la fabrication et les finitions pendant un an. Le fabricant aura le choix de réparer ou de remplacer l'un des éléments ci-dessus. Toutes les garanties sont limitées à l'acheteur d'origine uniquement. Cette garantie ne couvre pas la responsabilité de North Atlantic Imports, de ses agents ou de ses employés, pour les dommages indirects ou consécutifs résultant d'une violation de garantie. L'acheteur doit suivre les instructions d'utilisation du fabricant.

Le fabricant n'est en aucun cas responsable des dommages résultant de l'incapacité à utiliser correctement l'appareil de cuisson. Il incombe à l'acheteur d'établir la période de garantie en vérifiant la date d'achat d'origine à l'aide du reçu de vente.

Pour une explication plus approfondie de la garantie, lisez le message ci-dessous:

North Atlantic Imports LLC garantit au propriétaire que le produit couvert par le présent contrat est exempt de vices de matériau et de fabrication dans les conditions normales d'utilisation et de service auxquels il est destiné si, et seulement si, il a été utilisé conformément aux instructions de North Atlantic Imports LLC, et exclusivement dans le cadre d'un usage domestique et non d'une utilisation au sein d'un club privé ou public, dans un cadre institutionnel ou commercial.

En vertu de cette garantie, l'obligation de North Atlantic Imports LLC est limitée au remplacement ou à la réparation gratuite de toute pièce ou partie de l'appareil qui pourrait, à la satisfaction de North Atlantic Imports LLC, se révéler défectueuse dans les conditions normales d'utilisation et de service dans un cadre domestique, dans les délais indiqués à partir de la date d'achat; pendant un an à partir de l'achat, toutes les pièces, la fabrication et la finition. Si le non-respect de cette garantie devient apparent au cours des périodes de garantie applicables indiquées ci-dessus, l'acheteur

d'origine doit avertir North Atlantic Imports LLC de toute violation de la garantie pendant la période de garantie applicable.

North Atlantic Imports LLC s'engage, après avis émanant de l'acheteur d'origine et en cas de respect de ces instructions, à corriger une telle non-conformité en réparant ou en remplaçant la ou les pièce(s) défectueuse(s). Une correction telle qu'indiquée ci-dessus respecte toutes les obligations de North Atlantic Imports LLC en ce qui concerne la qualité du produit.

North Atlantic Imports LLC ne garantit pas que cet appareil respecte les exigences de tout code de sécurité de tout État, de toute municipalité ou de toute autre juridiction, et l'acheteur d'origine assume tous les risques et la responsabilité résultant de son utilisation, que celle-ci soit en conformité avec les instructions de North Atlantic Imports Instructions LLC ou non.

Cette garantie ne couvre pas et est destinée à exclure toute responsabilité de la part de North Atlantic, de ses agents, préposés ou employés,









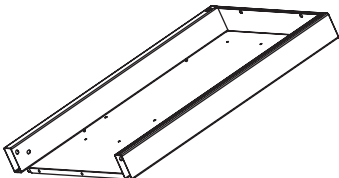
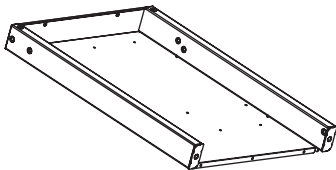
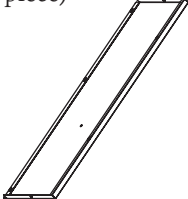
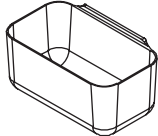

que ce soit en vertu de la présente garantie ou implicitement par la loi pour tout dommage indirect ou consécutif à une violation de la garantie. L'acheteur doit établir toutes les périodes de garantie applicables conformément à la présente garantie en vérifiant la date d'achat d'origine en fournissant le reçu daté. Cette garantie ne s'applique pas à ce produit ou à tout élément de celui-ci ayant été impliqué dans un accident, une négligence, une altération, un usage abusif ou inadéquat, ou ayant été réparé ou modifié sans autorisation écrite de l'atelier de North Atlantic Imports LLC.

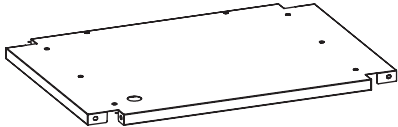
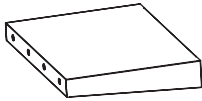
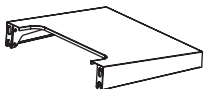
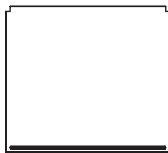
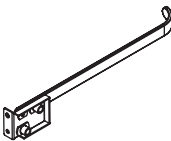
North Atlantic Imports LLC n'offre aucune garantie concernant les accessoires ou les pièces non fournies avec le produit. Cette garantie ne s'applique qu'à l'intérieur des frontières des États-Unis d'Amérique. Cette garantie confère à l'acheteur d'origine des droits spécifiques, et celui-ci peut également disposer d'autres droits, qui varient d'un État à un autre.

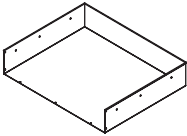
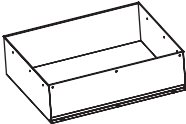
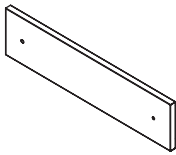
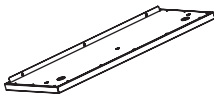

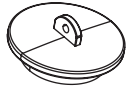
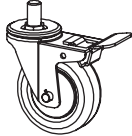
GUIDE DE MONTAGE

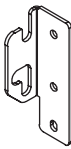
LISTE DES PIÈCES ILLUSTRÉES

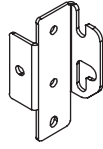
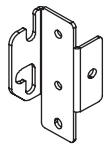
1 Table (1 pièce) 		2 Ensemble de jambe gauche (1 pièce) 		3 Assemblage de la jambe droite (1 pièce) 	
4 Panneau arrière gauche (1 pièce) 	5 Panneau arrière droit (1 pièce) 	6 Boîtes d'assaisonnement (3 pièces) 	7 Couvercles de boîtes d'assaisonnement (3 pièces) 	8 Base de chariot (1 pièce) 	
9 Tablette latérale gauche (1 pièce) 	10 Tablette latérale droite (1 pièce) 	11 Tablette intérieure (1 pièce) 	12 Porte-serviettes en papier (1 pièce) 	13 Support de sac poubelle (1 pièce) 	14 Ouvre-bouteille (1 pièce) 
15 Tiroir supérieur (1 pièce) 	16 Tiroir inférieur (1 pièce) 	17 Plaque frontale du tiroir supérieur (1 pièce) 	18 Plaque frontale du tiroir inférieur (1 pièce) 	19 Poignées de tiroir (2 pièces) 	20 Bouchon (1 pièce) 
21 Roulettes (2 pièces) 	22 Roues fixes (2 pièces) 	23 Support de tablette avant gauche (1 pièce) 	24 Support de tablette latérale avant droite (1 pièce) 	25 Support de tablette arrière gauche (1 pièce) 	26 Support de tablette latérale arrière droite (1 pièce) 



27 Pack matériel (1 pièce)

- a. Étape 2, 3: vis M4x10 (6 pièces)
- b. Étape 15, 7: vis M4x10 (14 pièces)
- c. Étape 5, 6: vis M4x10 (9 pièces)
- d. Étape 4: vis M6x12 (6 pièces)
- e. Étape 14: vis M4x10 (7 pièces)
- f. Étape 14: Écrous M4 (7 pièces)
- g. Étape 10, 11: rondelles de cheville en métal (8 pièces)
- h. Étape 9: vis M6x12 (14 pièces)
- i. Étape 12, 13, 19: Boulons M6 Step (8 pièces)
- j. Étape 10, 11: chevilles d'étagère (8 pièces)
- k. Étape 8, 17, 18: vis M6x12 (10 pièces)
- l. Pièces de rechange

The hardware pack includes:

- 27a: 6 screws (M4x10)
- 27b: 14 screws (M4x10)
- 27c: 9 screws (M4x10)
- 27d: 6 screws (M6x12)
- 27e: 7 screws (M4x10)
- 27f: 7 nuts (M4)
- 27g: 8 metal bracket washers
- 27h: 14 screws (M6x12)
- 27i: 8 M6 Step bolts
- 27j: 8 shelf brackets
- 27k: 10 screws (M6x12)

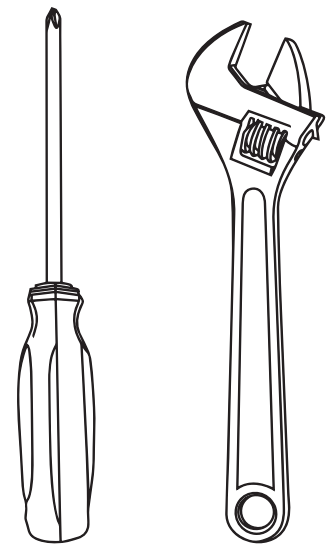
**OUTILS NÉCESSAIRES:**

Tournevis cruciforme et Clé à molette

**⚠ ATTENTION**

Le fabricant a tout mis en œuvre pour éliminer les bords tranchants. Cependant, vous devez manipuler tous les éléments avec soin pour éviter les blessures accidentelles.

Certaines pièces peuvent comporter des bords tranchants, notamment celles indiquées dans ces instructions. Portez des gants de protection si nécessaire.

⚠ ATTENTION

L'utilisation d'alcool, de médicaments sur ordonnance ou en vente libre peut nuire à la capacité du consommateur d'assembler correctement ou d'utiliser cet appareil en toute sécurité.

⚠ MISE EN GARDE

Il est recommandé de monter ce produit à deux personnes.

INSTRUCTIONS DE MONTAGE

Veillez lire attentivement toutes les instructions avant de continuer. Assurez-vous que tout le matériel d'emballage en plastique est enlevé avant de procéder à l'assemblage.

Trouvez une grande surface propre pour assembler votre gril. Veuillez vous référer à la liste des pièces et aux schémas d'assemblage si nécessaire.

ÉTAPE 01 Retirez l'assemblage du pied de joint de l'emballage. Desserrez les quatre (4) vis et séparez les ensembles de pieds gauche et droit.

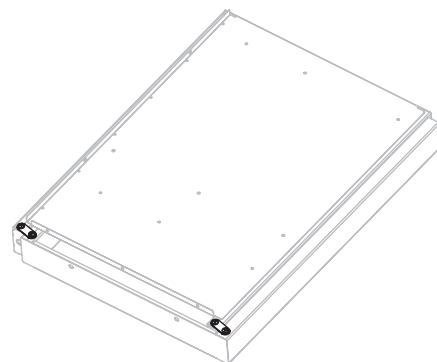

ÉTAPE 02 Utilisez trois (3) vis M4x10 pour fixer l'assemblage du pied gauche à la base du chariot.

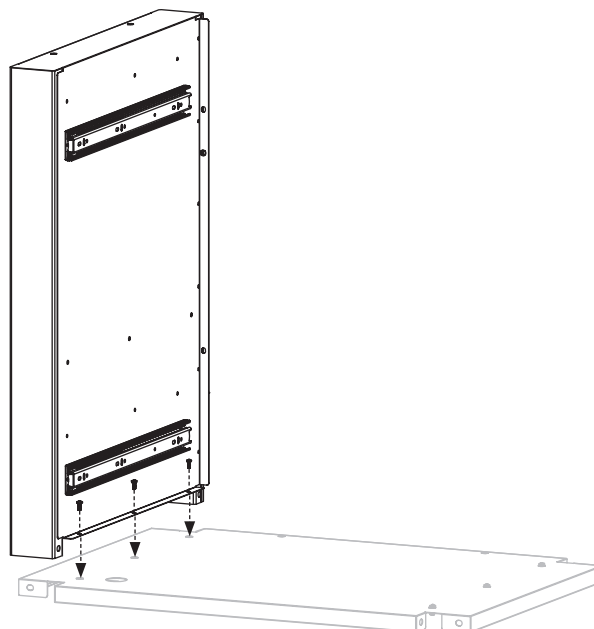



ÉTAPE 03 Utilisez trois (3) vis M4x10 pour fixer le pied droit à la base du chariot.

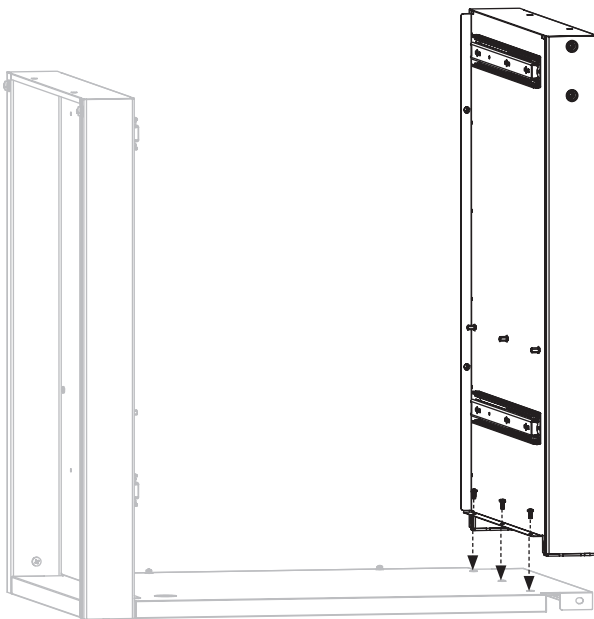

ÉTAPE 04 Avec l'aide d'une autre personne, retournez la base du chariot à l'envers. Utilisez six (6) vis M6x12 pour fixer les deux (2) roues fixes à l'assemblage du pied gauche. Utilisez quatre (4) vis M6x12 pour fixer les deux (2) roulettes à l'assemblage du pied droit.

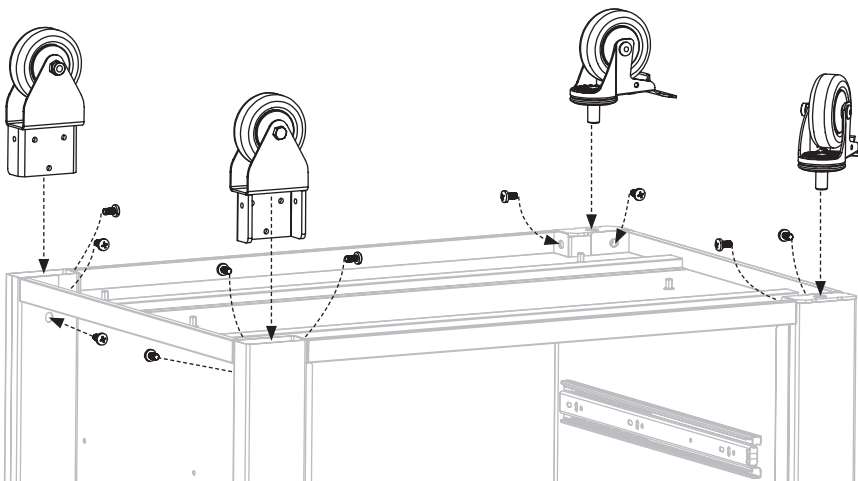
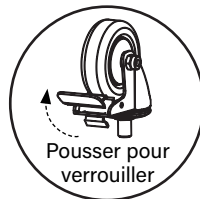



ÉTAPE 05 Avec l'aide d'une autre personne, placez le chariot debout sur ses roues. Utilisez deux (2) vis M4x10 pour fixer le panneau arrière droit à l'assemblage du pied droit. Utilisez une (1) vis M4x10 pour fixer le panneau arrière droit à la base du chariot.

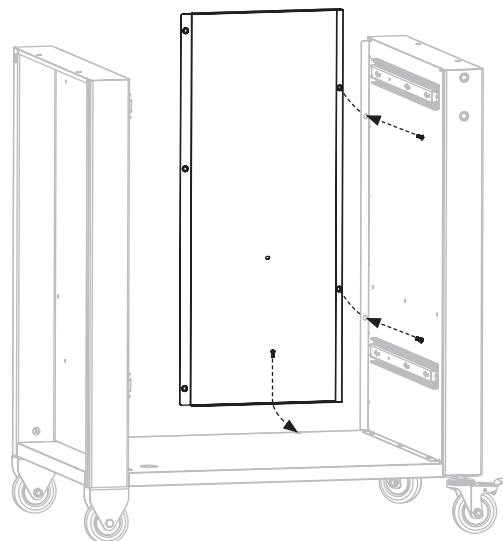

ÉTAPE 06 Utilisez deux (2) vis M4x10 pour fixer le panneau arrière gauche à l'assemblage du pied gauche. Utilisez une (1) vis M4x10 pour fixer le panneau arrière gauche à la base du chariot. Depuis l'arrière du panneau, utilisez trois (3) vis M4x10 pour fixer le panneau arrière gauche au panneau arrière droit.

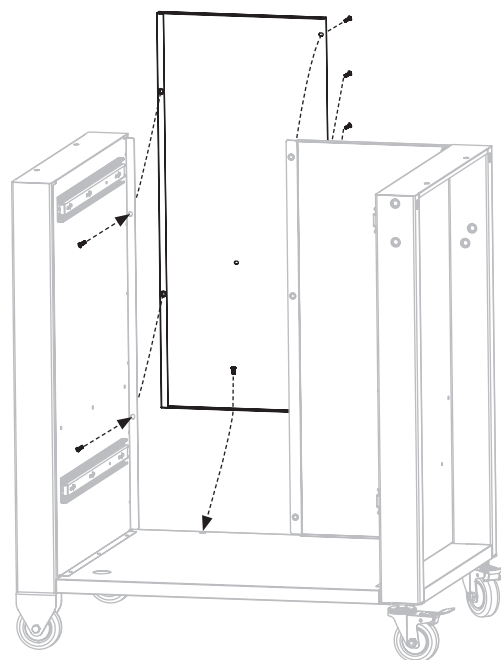



ÉTAPE 07 Utilisez huit (8) vis M4x10 pour installer la tablette intérieure sur le chariot (trois (3) vis sur chaque pied, une (1) sur chaque panneau arrière).

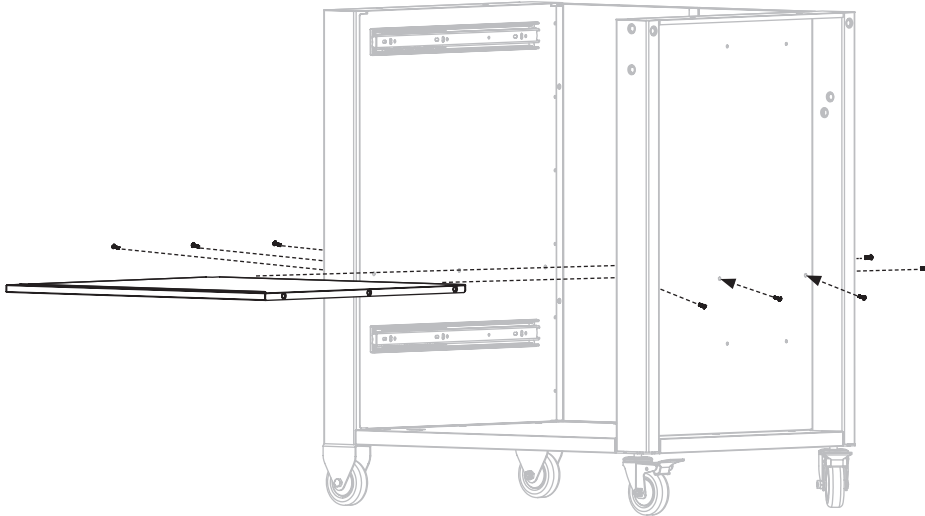

ÉTAPE 08 Placez la table sur le support et fixez-la avec six (6) vis M6x12 (deux (2) vis sur chaque pied, une (1) sur chaque panneau arrière).

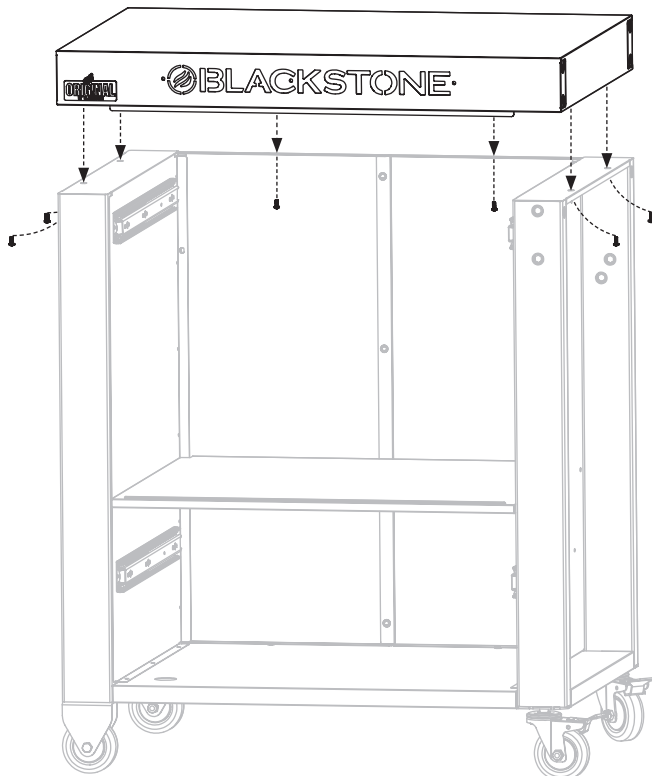



ÉTAPE 09 ① Utilisez trois (3) vis M6x12 pour fixer le support de tablette avant gauche sur le côté gauche du chariot. ② Utilisez quatre (4) vis M6x12 pour fixer le support de tablette latérale arrière gauche sur le côté gauche du chariot. ③ Utilisez trois (3) vis M6x12 pour fixer le support de tablette avant droite sur le côté droit du chariot. ④ Utilisez quatre (4) vis M6x12 pour fixer le support de tablette arrière droite sur le côté droit du chariot.

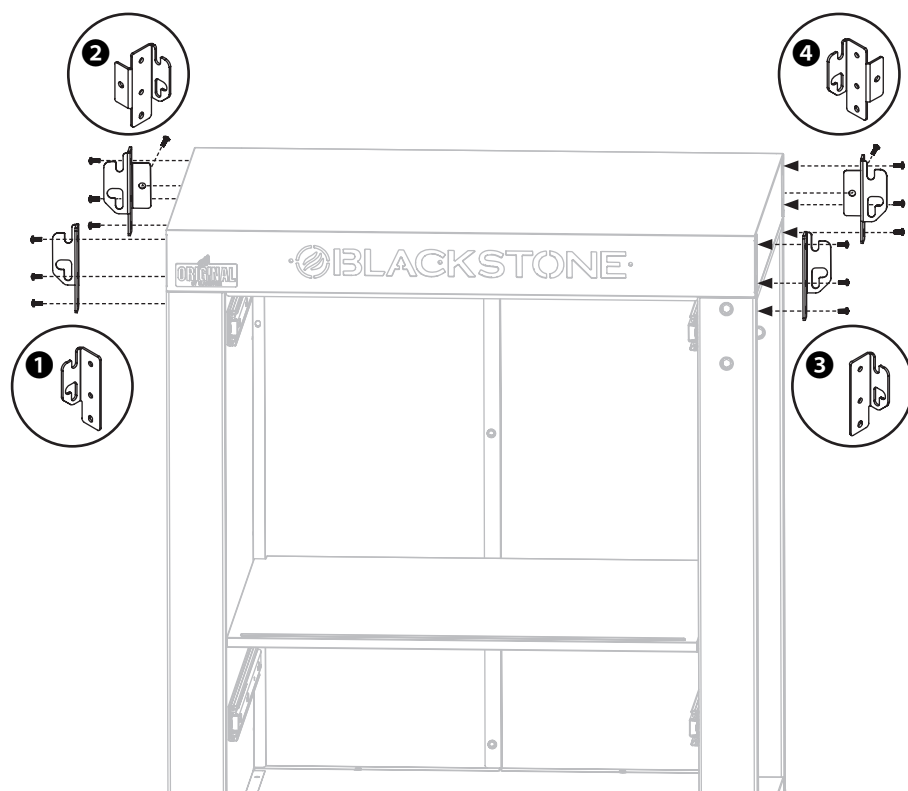

ÉTAPE 10 Vissez quatre (4) chevilles de tablette latérale dans quatre (4) rondelles de cheville et les trous prédécoupés de la tablette latérale gauche.

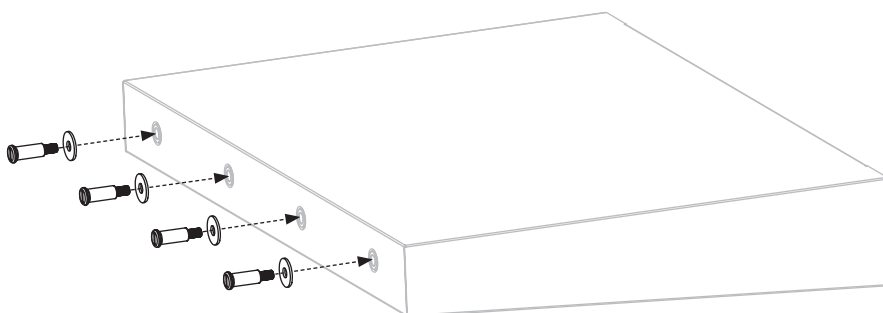



ÉTAPE 11 Vissez quatre (4) chevilles de tablette latérale dans quatre (4) rondelles de cheville et les trous prédécoupés de la tablette latérale droite.

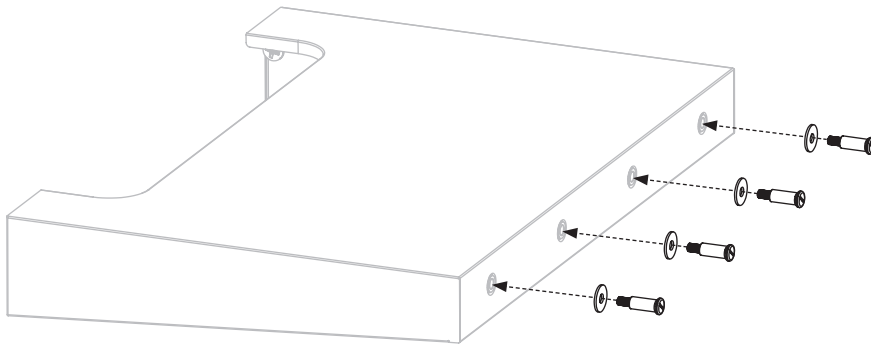

ÉTAPE 12 Accrochez la tablette latérale gauche aux supports de la tablette et utilisez deux (2) boulons étagés pour la fixer à travers les trous inférieurs.

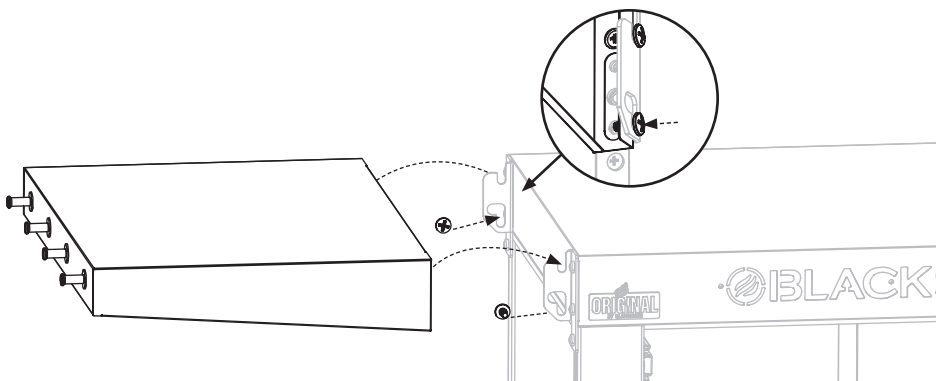

ÉTAPE 13 Accrochez la tablette latérale droite sur les supports de la tablette et utilisez deux (2) boulons étagés pour la fixer à travers les trous inférieurs.

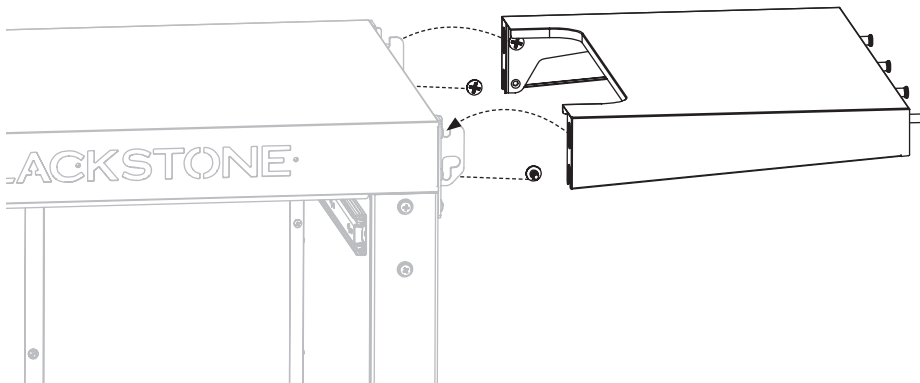

ÉTAPE 14 Utilisez deux (2) vis M6x12 pour installer une (1) poignée de tiroir sur la plaque avant du tiroir supérieur.

Utilisez sept (7) vis M4x10 et sept (7) écrous pour fixer la plaque avant au tiroir supérieur.

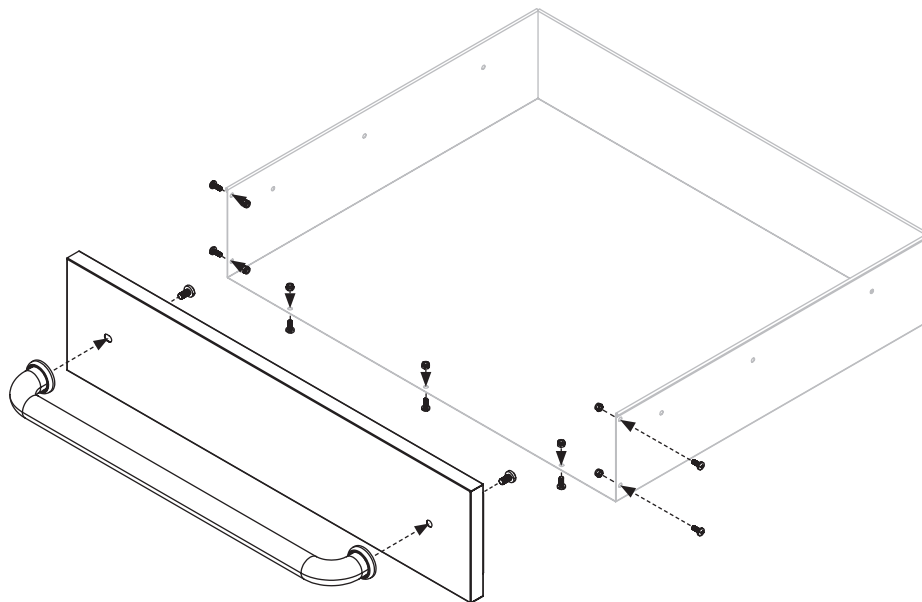

ÉTAPE 15 Utilisez deux (2) vis M6x12 pour installer une (1) poignée de tiroir sur la plaque avant du tiroir inférieur.

Utilisez six (6) vis M4x10 pour fixer la plaque avant au tiroir inférieur.

Insérez le bouchon dans le trou prédécoupé du tiroir inférieur. (Le tiroir inférieur peut stocker de la glace et de l'eau.)

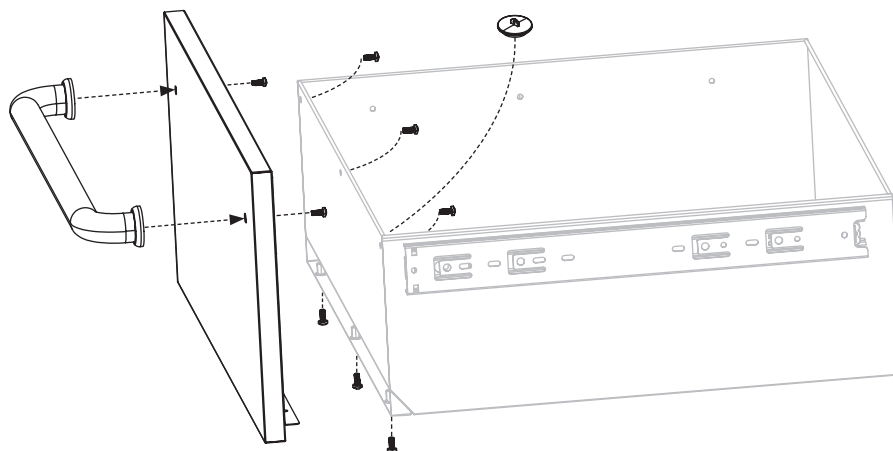



ÉTAPE 16 Alignez et insérez le tiroir supérieur et les tiroirs inférieurs dans leurs glissières respectives.

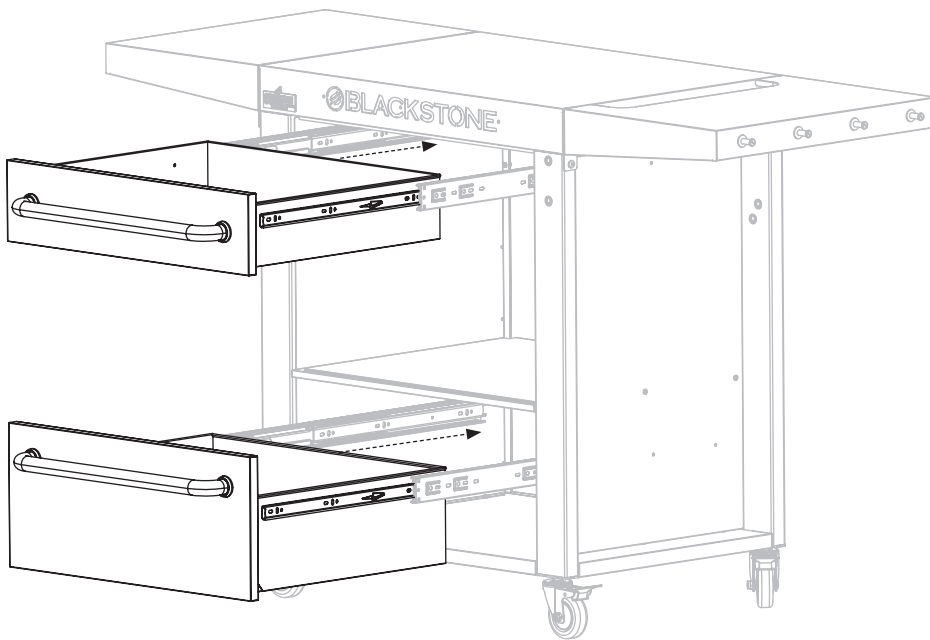

ÉTAPE 17 Desserrez la vis du bras du support de l'essuie-tout et retirez le bras du support de l'essuie-tout, puis utilisez deux (2) vis M6x12 pour fixer le support de la tour de papier sur le côté gauche de l'unité. Rattachez le bras porte-serviettes en papier.

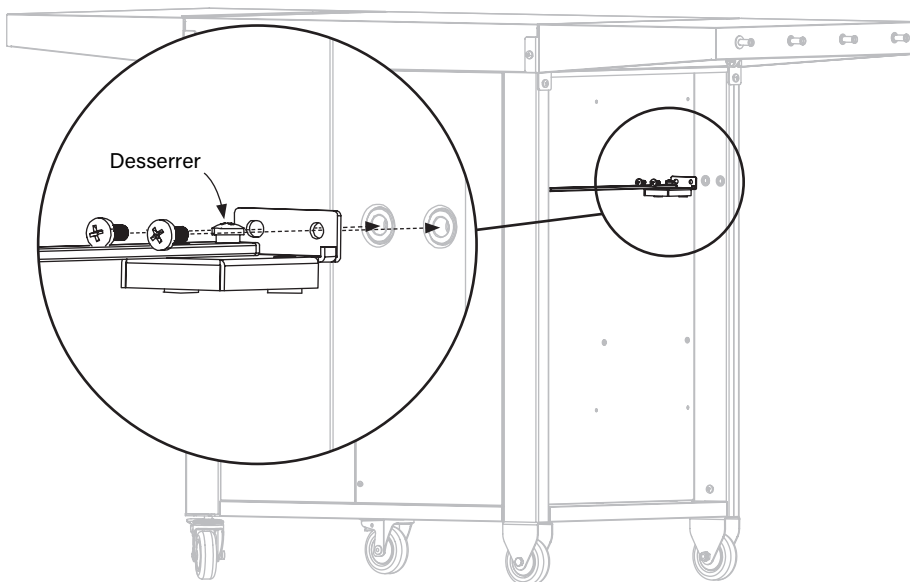



ÉTAPE 18 Utilisez deux (2) vis M6x12 pour fixer l'ouvre-bouteille au pied droit.



ÉTAPE 19 Vissez deux (2) boulons étagés M4 dans les trous inférieurs de l'assemblage du pied droit. Ensuite, alignez les boucles du support de sac poubelle sur les trous supérieurs de l'assemblage du pied droit et utilisez deux (2) boulons étagés M4 pour fixer.

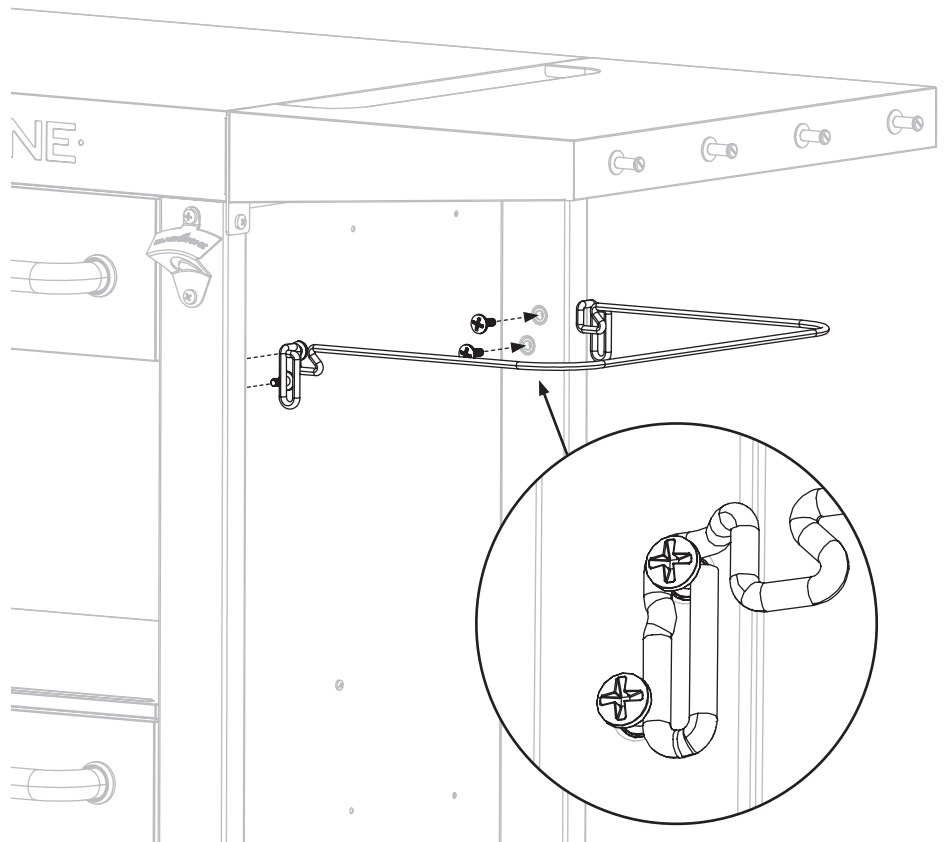



ÉTAPE 20 Profitez de la cuisine en plein air avec votre Servir et stocker le chariot de préparation Blackstone!

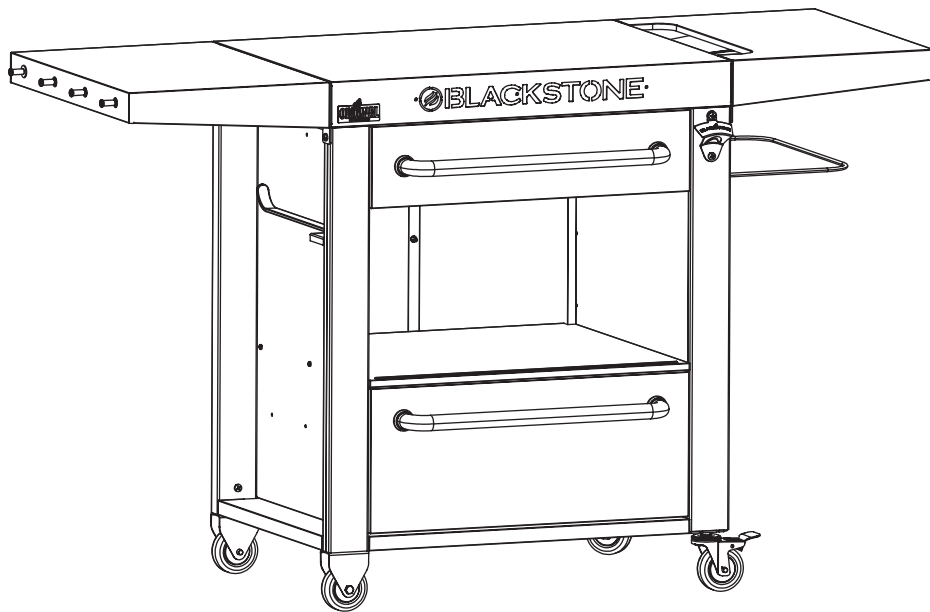

Rangez les feuilles de laurier, les légumes en dés, les épices et plus encore dans vos boîtes d'assaisonnements!

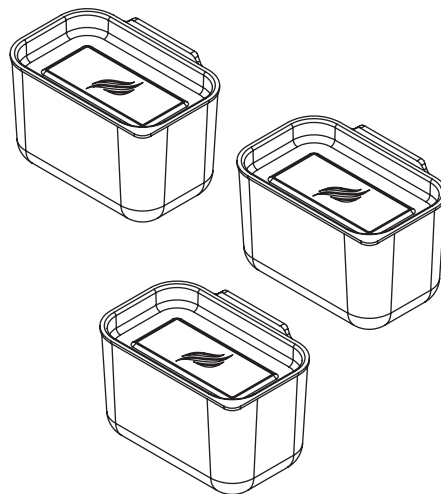

NOTRE PERSONNEL DU SERVICE À LA CLIENTÈLE EST LÀ POUR VOUS AIDER!

Enregistrez votre produit Blackstone sur blackstoneproducts.com/register et visitez-nous en ligne sur blackstoneproducts.com/support



Nous sommes heureux de vous aider pour toute question concernant l'utilisation de l'appareil, les pièces de rechange ou votre garantie.

*Heures de service à la clientèle:
Lundi au vendredi
7 h à 17 h
Heure normale des Rocheuses.*

Modelo 1938

CARRITO DE PREPARACIÓN

PARA SERVIR Y ALMACENAR

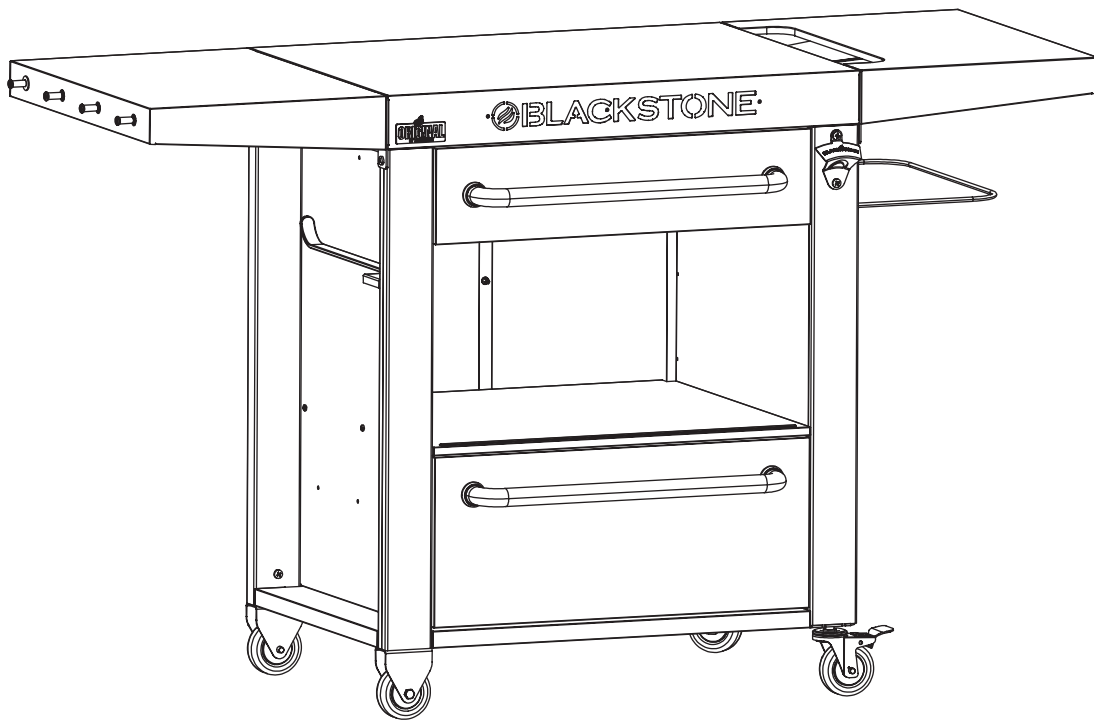

Consulte blackstoneproducts.com/support para obtener la última versión de este manual y seguir los videos de montaje.



TABLA DE CONTENIDO

Es responsabilidad del consumidor asegurarse de que la unidad esté correctamente ensamblada, instalada y mantenida. El incumplimiento de las instrucciones de este manual puede provocar lesiones corporales y / o daños a la propiedad.

CONTENIDO

01. GARANTÍA	01
02. GUÍA DE MONTAJE	02

LLAVE DE ALERTA DE SEGURIDAD

Lea y siga todos los avisos que se encuentran en el manual.

PELIGRO

Indica una situación de peligro inminente que, si no se evita, puede causar la muerte o lesiones graves.

ADVERTENCIA

Indica la posibilidad de lesiones corporales graves si no se siguen las instrucciones.

PRECAUCIÓN

Indica una situación potencialmente peligrosa que, si no se evita, puede resultar en una lesión moderada.



NORTH ATLANTIC IMPORTS LLC

GARANTÍA DE 1 AÑO

North Atlantic Imports, el fabricante, garantizará por un año a partir de la compra a todas las piezas, mano de obra y acabados. Será la opción del fabricante en cuanto a si reparar o reemplazar cualquiera de los elementos anteriores. Todas las garantías están limitadas únicamente al comprador original. Esta garantía no cubre ninguna responsabilidad por parte de North Atlantic Imports, sus agentes o empleados, por cualquier daño indirecto o consecuente por incumplimiento de la garantía. El comprador debe seguir las instrucciones de uso del fabricante.

Bajo ninguna circunstancia, el fabricante es responsable de los daños causados por el hecho de no operar correctamente la estación de cocción. Es responsabilidad del comprador establecer el período de garantía al verificar la fecha de compra original con el recibo de compra original.

Para obtener una explicación más detallada de la garantía, lea a continuación:

North Atlantic Imports LLC garantiza al propietario que el producto cubierto por este acuerdo está libre de defectos en el material y la mano de obra bajo el uso y servicio normales para los cuales fue diseñado, pero solo si ha sido operado de acuerdo con las instrucciones de North Atlantic Imports LLC exclusivamente para uso doméstico, y no para fines de clubes privados o públicos, institucionales o comerciales.

La obligación de North Atlantic Imports LLC bajo esta garantía se limita a reemplazar o reparar, sin cargo alguno, cualquier parte o partes que se puedan demostrar, a satisfacción de North Atlantic Imports LLC, que son defectuosas en el uso y servicio normales en el hogar dentro de los siguientes períodos indicados de tiempo desde la fecha de compra; por un año desde la compra, todas las piezas, el acabado y la mano de obra. Si el incumplimiento de esta garantía se hace evidente durante los períodos de garantía aplicables mencionados anteriormente, el comprador original debe notificar a North Atlantic Imports LLC sobre el incumplimiento

de la garantía dentro del período de garantía correspondiente.

North Atlantic Imports LLC deberá, previa notificación y cumplimiento por parte del comprador original de tales instrucciones, corregir dicha no conformidad mediante la reparación o reemplazo de la pieza o piezas defectuosas. La corrección en la forma provista anteriormente constituirá un cumplimiento de todas las obligaciones de North Atlantic Imports LLC con respecto a la calidad del producto.

North Atlantic Imports LLC no garantiza que este equipo cumpla con el requisito de ningún código de seguridad de ningún estado, municipio u otra jurisdicción, y el comprador original asume todos los riesgos y responsabilidades que resulten del uso de los mismos, ya sean utilizados de acuerdo con las instrucciones de North Atlantic Imports LLC o de otra manera.

Esta garantía no cubre y tiene la intención de excluir cualquier responsabilidad por parte de North Atlantic a sus agentes, trabajadores o empleados, ya sea en virtud de esta





garantía o de la ley implícita por cualquier daño indirecto o consecuente por incumplimiento de cualquier garantía. El comprador debe establecer todos los períodos de garantía aplicables de conformidad con esta garantía verificando la fecha de compra original al presentar el recibo de venta con fecha. Esta garantía no se aplicará a este producto ni a ninguna otra parte del mismo que haya sido objeto de accidente, negligencia, alteración, abuso o mal uso, o que haya sido reparada o alterada sin el consentimiento por escrito del North Atlantic, fuera de la fábrica de North Atlantic Imports LLC.

North Atlantic Imports LLC no ofrece ninguna garantía con respecto a los accesorios o piezas no suministrados por ellos. Esta garantía se aplicará solo dentro de los límites de los Estados Unidos de América. Esta garantía otorga al comprador original derechos específicos, y el comprador original también puede tener otros derechos, que varían de un estado a otro.

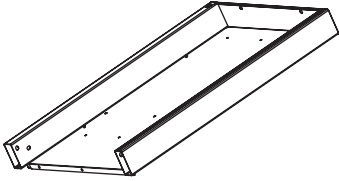
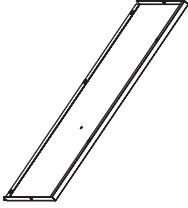

GUÍA DE MONTAJE

LISTA DE PIEZAS ILUSTRADA

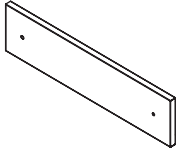
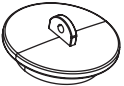
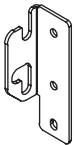
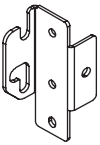
1 Mesa (1 pieza) 		2 Conjunto de pierna izquierda (1 pieza) 		3 Conjunto de pierna derecha (1 pieza) 	
4 Panel trasero izquierdo (1 pieza) 	5 Panel trasero derecho (1 pieza) 	6 Cajas de condimentos (3 piezas) 	7 Tapas de caja de condimentos (3 piezas) 	8 Base de carro (1 pieza) 	
9 Repisa lateral izquierda (1 pieza) 	10 Right side shelf (1 piece) 	11 Balda interior (1 pieza) 	12 Porta toallas de papel (1 pieza) 	13 Soporte para bolsa de basura (1 pieza) 	14 Abrebotellas (1 pieza) 
15 Cajón superior (1 pieza) 	16 Cajón inferior (1 pieza) 	17 Placa frontal del cajón superior (1 pieza) 	18 Placa frontal del cajón inferior (1 pieza) 	19 Tiradores de cajón (2 piezas) 	20 Enchufe (1 pieza) 
21 Ruedas giratorias (2 piezas) 	22 Ruedas fijas (2 piezas) 	23 Soporte del estante del lado delantero izquierdo (1 pieza) 	24 Soporte de estante del lado delantero derecho (1 pieza) 	25 Soporte de estante lateral trasero izquierdo (1 pieza) 	26 Soporte de estante lateral trasero derecho (1 pieza) 



27 Paquete de hardware (1 pieza)

- a.** Paso 2, 3: tornillos M4x10 (6 piezas)
- b.** Paso 15, 7: tornillos M4x10 (14 piezas)
- c.** Paso 5, 6: tornillos M4x10 (9 piezas)
- d.** Paso 4: tornillos M6x12 (6 piezas)
- e.** Paso 14: tornillos M4x10 (7 piezas)
- f.** Paso 14: tuercas M4 (7 piezas)
- g.** Paso 10, 11: Arandelas de clavija de metal (8 piezas)
- h.** Paso 9: tornillos M6x12 (14 piezas)
- i.** Paso 12, 13, 19: Pernos de paso M6 (8 piezas)
- j.** Paso 10, 11: Clavijas de estante (8 piezas)
- k.** Paso 8, 17, 18: tornillos M6x12 (10 piezas)
- l.** Repuestos

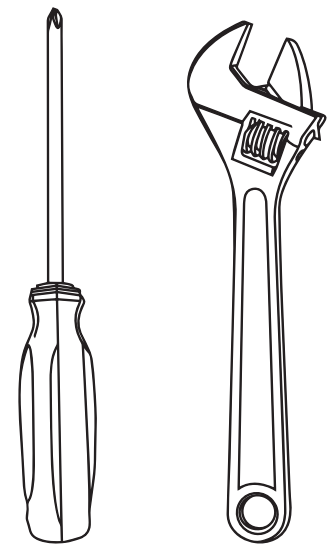

HERRAMIENTAS NECESARIAS:
Destornillador Phillips y Llave ajustable



⚠ ADVERTENCIA

El fabricante ha hecho todo lo posible para eliminar los bordes afilados. Sin embargo, debe manejar todos los componentes con cuidado para evitar lesiones accidentales.

Algunas partes pueden contener bordes afilados, especialmente como se indica en estas instrucciones. Use guantes de protección si es necesario.

⚠ ADVERTENCIA

El uso de alcohol, medicamentos recetados o sin receta puede afectar la capacidad del consumidor para ensamblar u operar el aparato de manera segura.

⚠ PRECAUCIÓN

Se recomiendan dos personas para el montaje de este producto.

INSTRUCCIONES DE MONTAJE

Lea atentamente todas las instrucciones antes de continuar. Asegúrese de retirar todo el material de embalaje de plástico antes de ensamblarlo.

Encuentre un área grande y limpia para ensamblar su unidad. Consulte la lista de piezas y los diagramas de ensamblaje según sea necesario.

PASO 01 Retire el conjunto de la pata de la articulación del embalaje. Afloje los cuatro (4) tornillos y separe los conjuntos de patas izquierda y derecha.

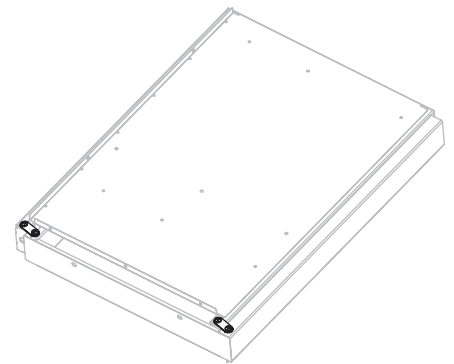

PASO 02 Utilice tres (3) tornillos M4x10 para sujetar el conjunto de la pata izquierda a la base del carro.

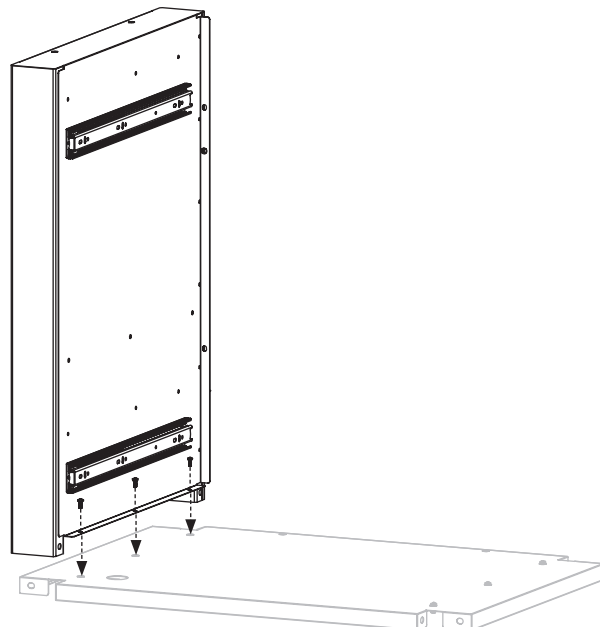



PASO 03 Utilice tres (3) tornillos M4x10 para sujetar el conjunto de la pata derecha a la base del carro.

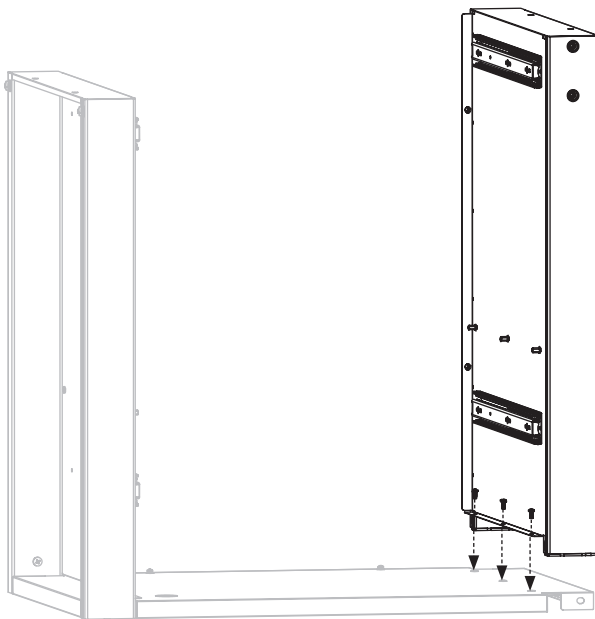

PASO 04 Con la ayuda de otra persona, voltee la base del carro al revés. Utilice seis (6) tornillos M6x12 para sujetar las dos (2) ruedas fijas al conjunto de la pata izquierda. Utilice cuatro (4) tornillos M6x12 para sujetar las dos (2) ruedas giratorias al conjunto de la pata derecha.

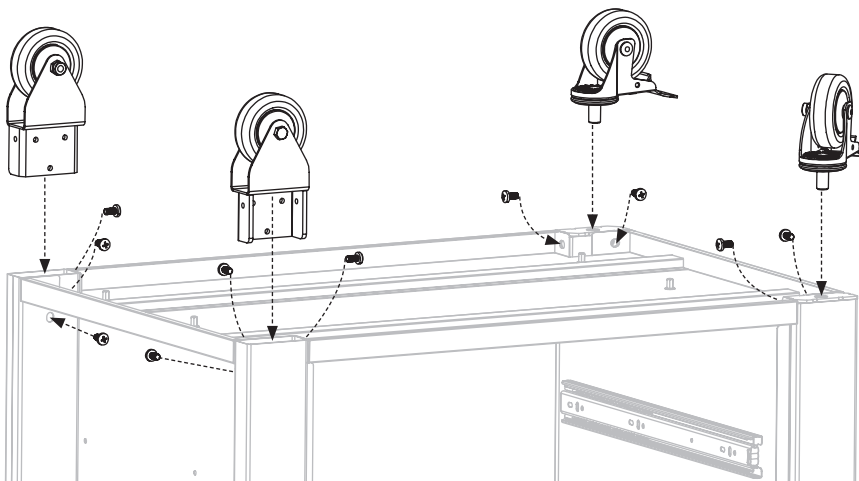
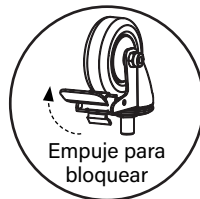



PASO 05 Con la ayuda de otra persona, coloque el carro en posición vertical sobre sus ruedas. Use dos (2) tornillos M4x10 para sujetar el panel trasero derecho al ensamblaje de la pata derecha. Utilice un (1) tornillo M4x10 para sujetar el panel trasero derecho a la base del carro.

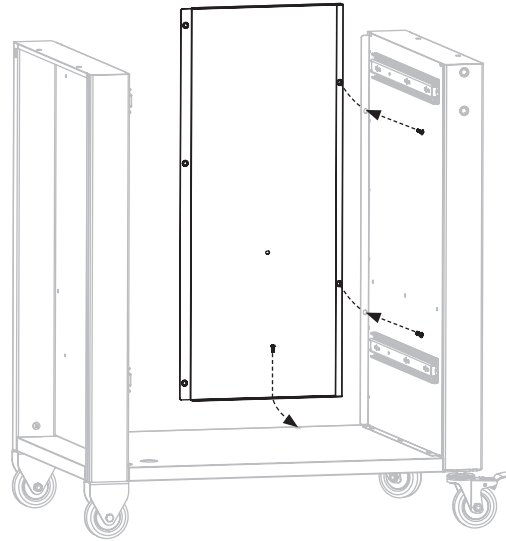

PASO 06 Use dos (2) tornillos M4x10 para sujetar el panel trasero izquierdo al ensamblaje de la pata izquierda. Utilice un (1) tornillo M4x10 para sujetar el panel trasero izquierdo a la base del carro. Desde la parte posterior del panel, use tres (3) tornillos M4x10 para sujetar el panel posterior izquierdo al panel posterior derecho.

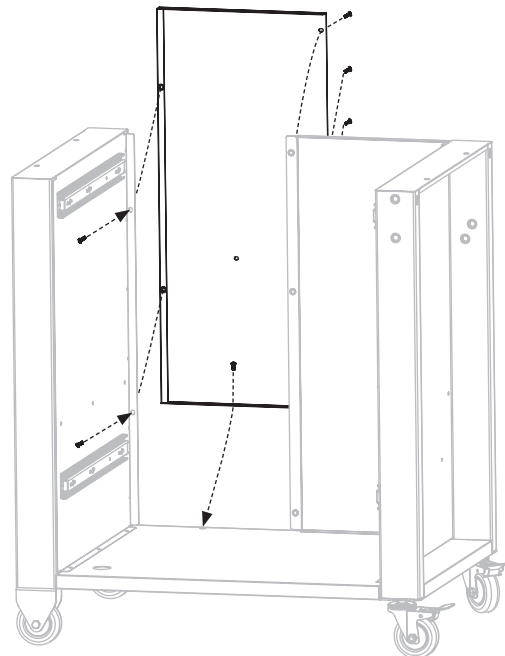



PASO 07 Utilice ocho (8) tornillos M4x10 para instalar el estante interior en el carro (tres (3) tornillos en cada conjunto de patas, uno (1) en cada panel posterior).

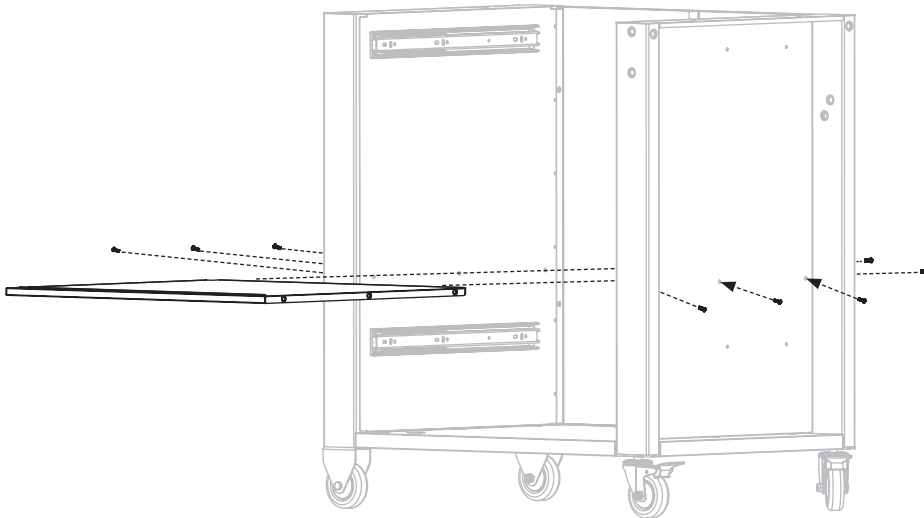

PASO 08 Coloque la mesa sobre el soporte y asegúrela con seis (6) tornillos M6x12 (dos (2) tornillos en cada conjunto de patas, uno (1) en cada panel posterior).

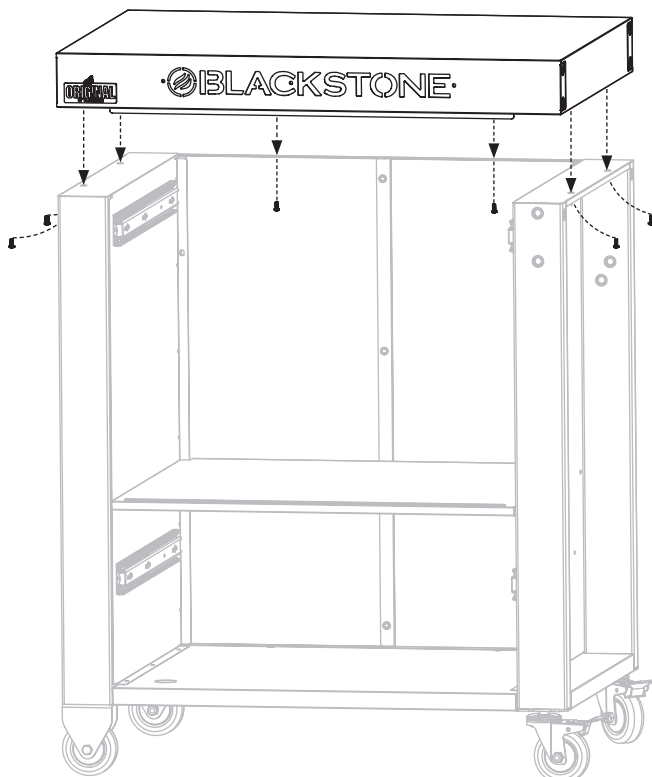



PASO 09 ❶ Utilice tres (3) tornillos M6x12 para fijar el soporte del estante del lado frontal izquierdo al lado izquierdo del carrito. ❷ Utilice cuatro (4) tornillos M6x12 para fijar el soporte del estante lateral trasero izquierdo al lado izquierdo del carrito. ❸ Utilice tres (3) tornillos M6x12 para sujetar el soporte del estante del lado frontal derecho al lado derecho del carrito. ❹ Utilice cuatro (4) tornillos M6x12 para fijar el soporte del estante lateral trasero derecho al lado derecho del carrito.

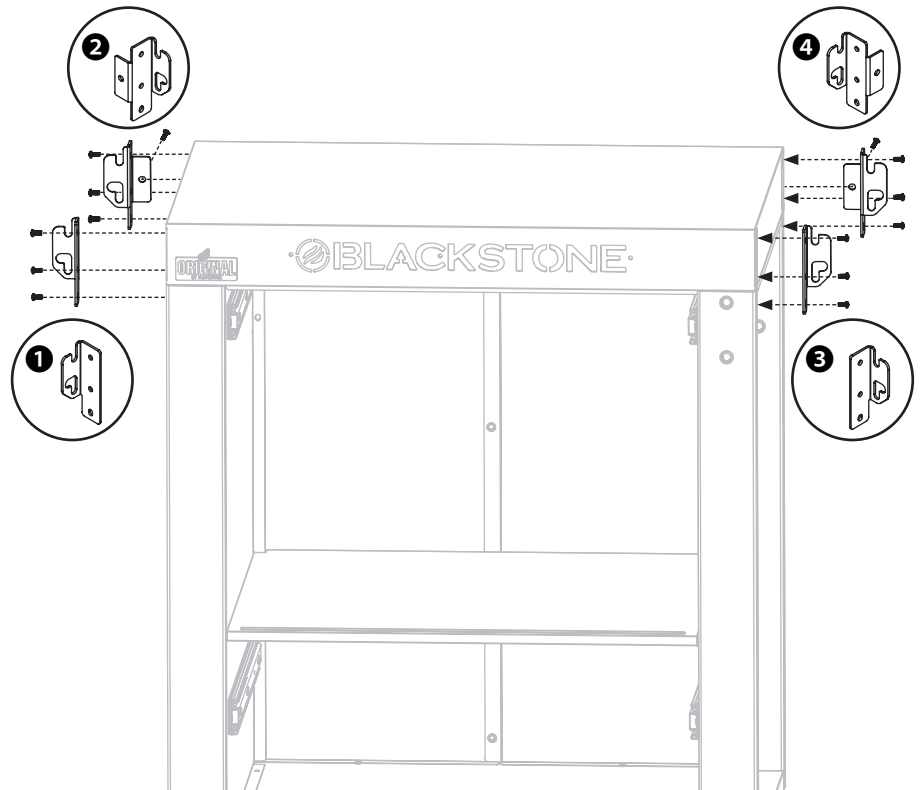

PASO 10 Enrosque cuatro (4) clavijas del estante lateral en cuatro (4) arandelas de clavija y los orificios precortados del estante lateral izquierdo.

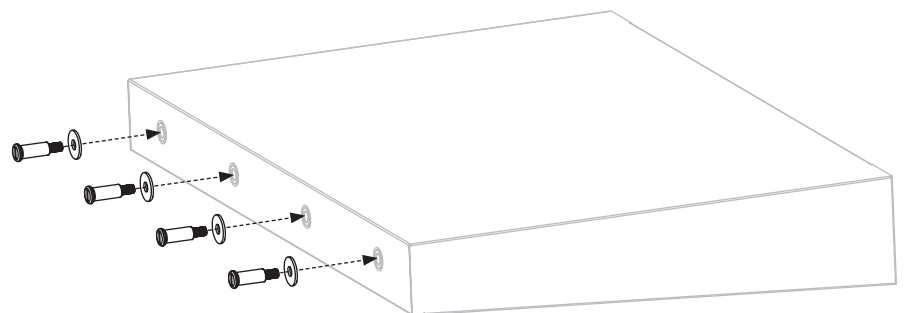



PASO 11 Enrosque cuatro (4) clavijas del estante lateral en cuatro (4) arandelas de clavija y los orificios precortados del estante lateral derecho.

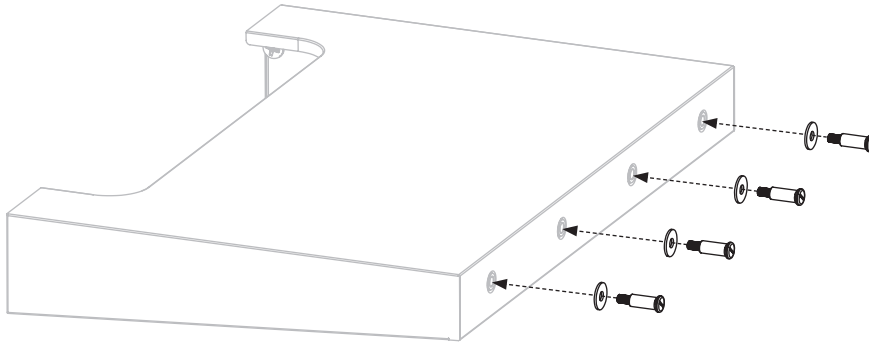

PASO 12 Enganche el estante del lado izquierdo en los soportes del estante y use dos (2) pernos escalonados para asegurarlo a través de los orificios inferiores.

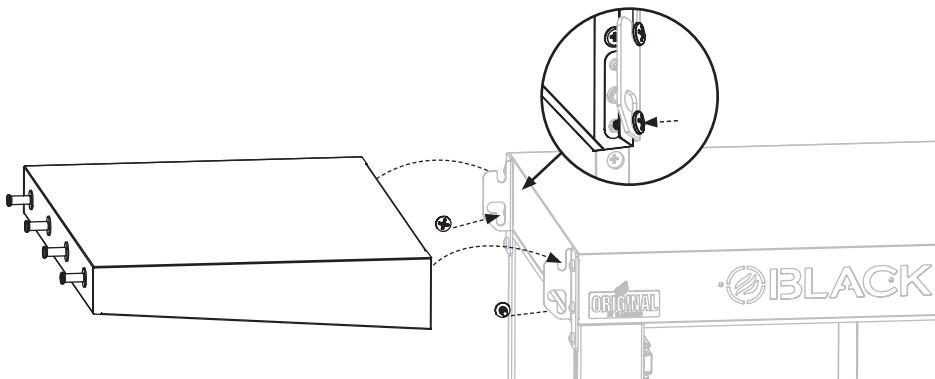

PASO 13 Enganche el estante del lado derecho en los soportes del estante y use dos (2) pernos escalonados para asegurarlo a través de los orificios inferiores.

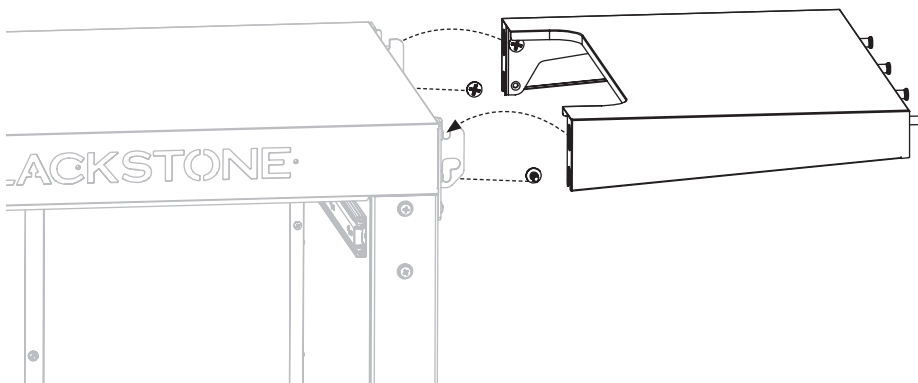



PASO 14 Utilice dos (2) tornillos M6x12 para instalar una (1) manija de cajón en la placa frontal del cajón superior.

Utilice siete (7) tornillos M4x10 y siete (7) tuercas para sujetar la placa frontal al cajón superior.

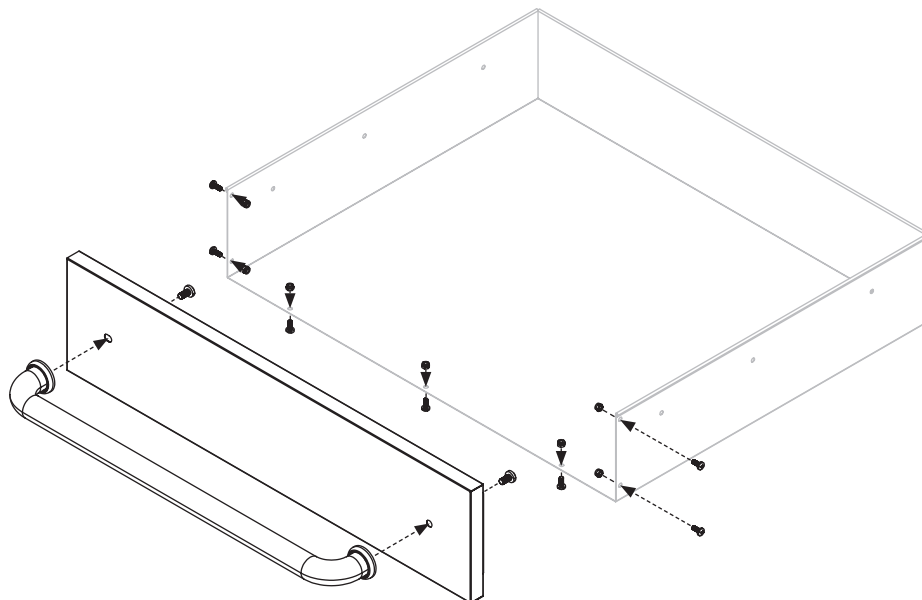

PASO 15 Utilice dos (2) tornillos M6x12 para instalar una (1) manija de cajón en la placa frontal del cajón inferior.

Utilice seis (6) tornillos M4x10 para fijar la placa frontal al cajón inferior.

Inserte el tapón en el orificio precortado del cajón inferior. (El cajón inferior puede almacenar hielo y agua).

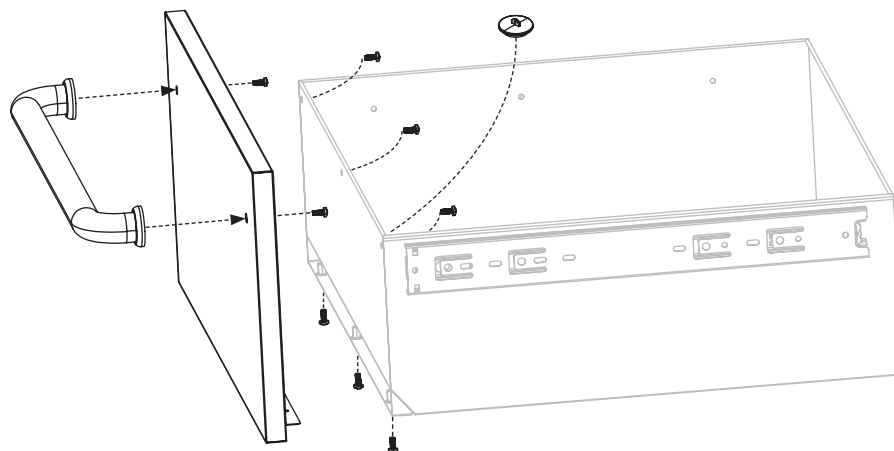



PASO 16 Alinee e inserte el cajón superior e inferior en sus respectivas guías.

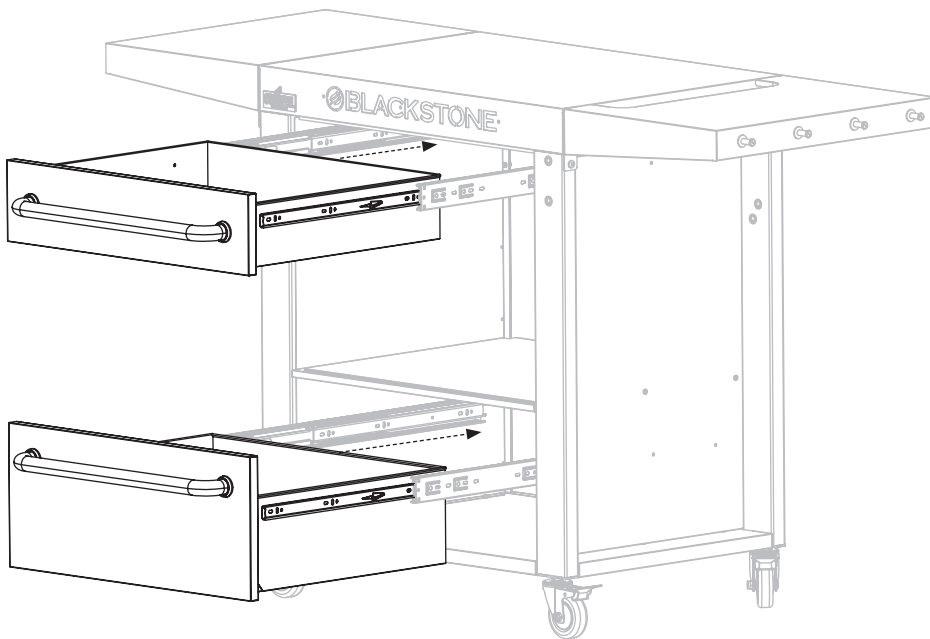

PASO 17 Afloje el tornillo del brazo del soporte de la toalla de papel y retire el brazo del soporte de la toalla de papel, luego use dos (2) tornillos M6x12 para fijar el soporte de la torre de papel al lado izquierdo de la unidad. Vuelva a colocar el brazo del soporte de toallas de papel.

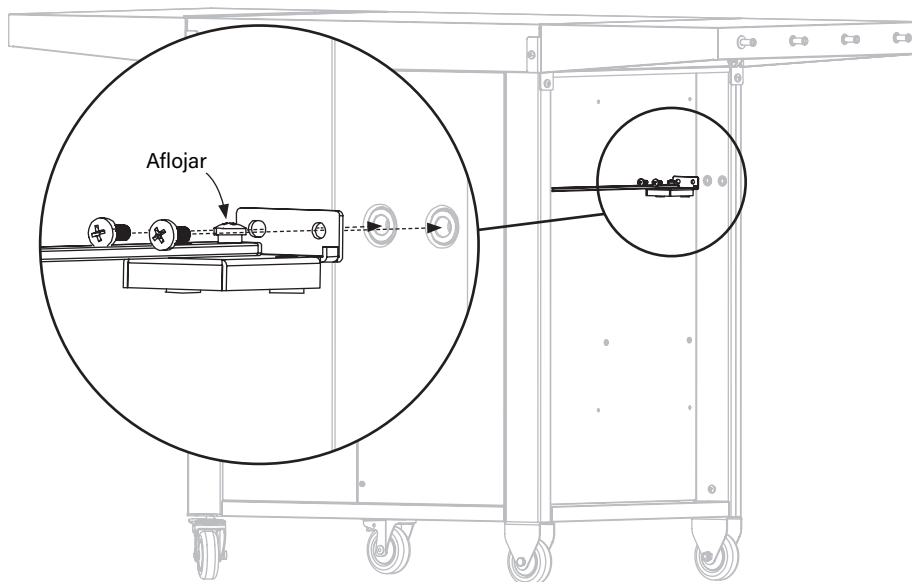



PASO 18 Utilice dos (2) tornillos M6x12 para sujetar el abrebotellas al conjunto de la pata derecha.

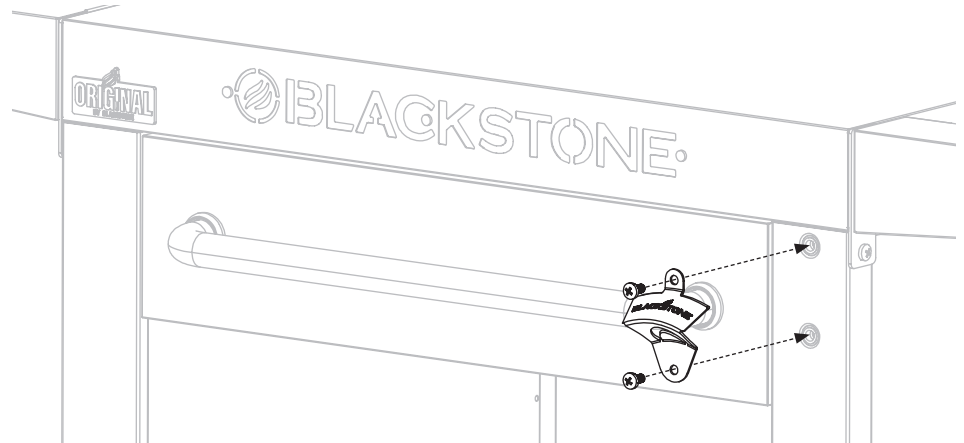

PASO 19 Atornille dos (2) pernos escalonados M4 en los orificios inferiores del conjunto de la pata derecha. Luego, alinee los lazos del soporte de la bolsa de basura con los orificios superiores en el ensamblaje de la pata derecha y use dos (2) pernos escalonados M4 para asegurar.

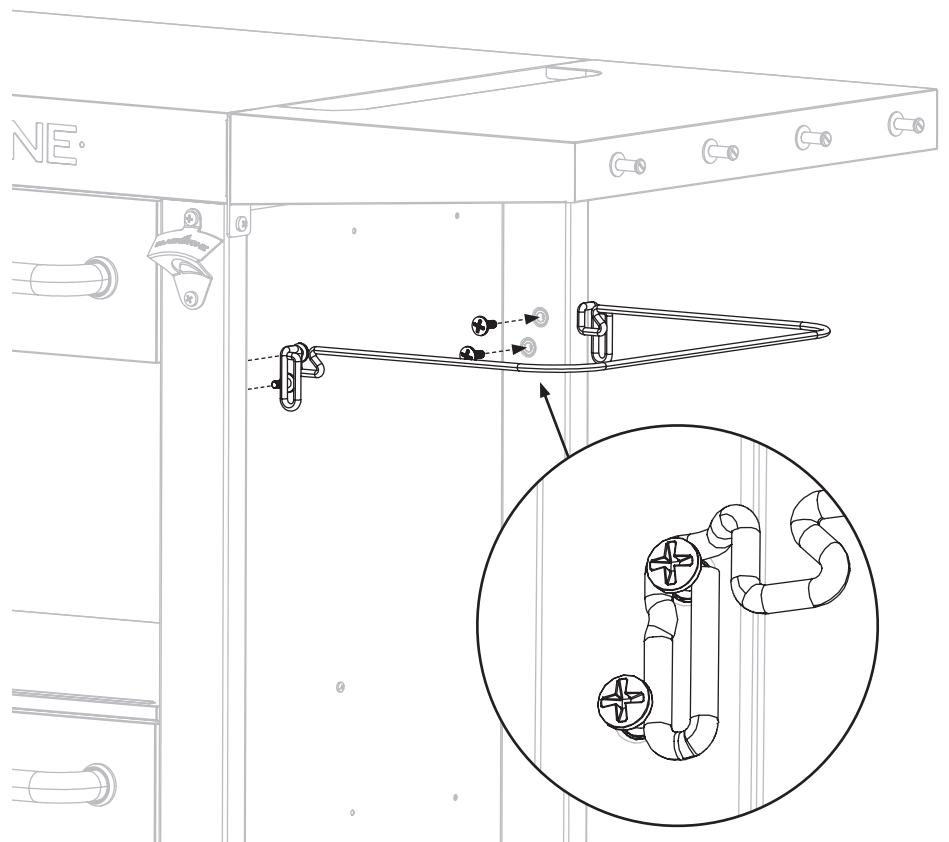



PASO 20 ¡Disfruta cocinando al aire libre con tu Carrito de preparación para servicio y tienda Blackstone!

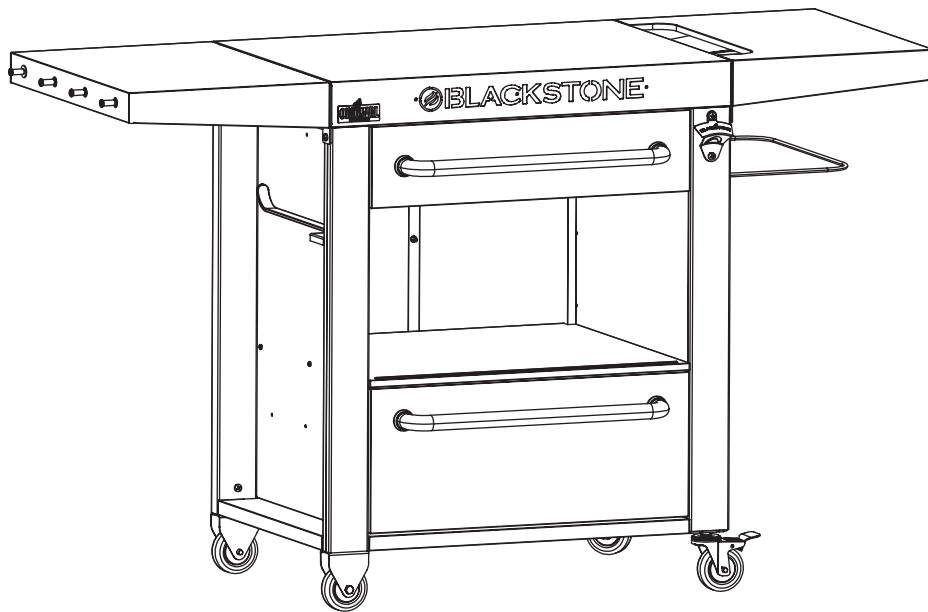

¡Guarde hojas de laurel, vegetales cortados en cubitos, especias y más en sus cajas de condimentos!

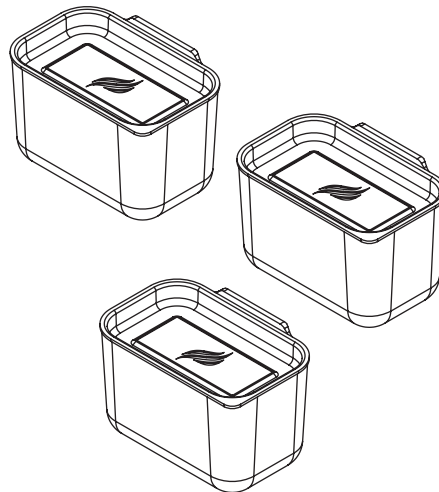

¡NUESTRO PERSONAL DE SERVICIO AL CLIENTE ESTÁ AQUÍ PARA AYUDARLO!

Registre su producto Blackstone en blackstoneproducts.com/register y visítenos en línea en blackstoneproducts.com/support



Nos complace ayudarlo con cualquier pregunta relacionada con el uso del aparato., las piezas de repuesto o su garantía.

Horario de atención al cliente:
Lunes a viernes
7:00 a.m. a 5:00 p.m
Hora estándar de la montaña

