



Installation, Operation and Maintenance Manual

November 2021



Table of contents

1	General instructions.....	2
1.1	Essentials.....	2
1.2	Installation.....	3
1.3	Test & Start Procedures.....	3
1.4	Maintenance.....	4
1.5	Motors.....	4
1.6	Warranty.....	5
1.7	Explosion Resistant products.....	6
1.8	Declaration of Conformity.....	7
2	PLASTEC utility and Storm Blowers	8
2.1	Disassembly Instructions.....	8
2.2	Reassembly Instructions.....	8
2.3	Illustration: Plastec Utility and Storm Blower.....	9
2.4	Illustrations: Attachment of PLASTEC Fan to Weather Hood.....	10
3	PLASTEC PSS Series Stainless Steel Utility Blowers	11
3.1	Disassembly Instructions.....	11
3.2	Reassembly instructions.....	11
3.3	Illustration: PSS Series – PSS20 and PSS35.....	12
4	PLASTEC JET Series	13
4.1	Disassembly Instructions.....	13
4.2	Reassembly Instructions.....	13
4.3	Illustration: Jet Series.....	14
5	Roof Unit Kits.....	15
5.1	Roof Unit 15 – Roof Unit 30 Kit Assembly.....	15
5.2	Roof Unit 35 Kit Assembly.....	18
6	Electrical wiring.....	19
6.1	General Precautions.....	19
6.2	Diagram.....	19
6.2.1	TechTop wiring.....	19



1 General instructions

1.1 Essentials

1.1.1 Introduction

DO NOT INSTALL, USE OR OPERATE THIS EQUIPMENT UNTIL THIS MANUAL HAS BEEN FULLY READ AND UNDERSTOOD. RETAIN THESE INSTRUCTIONS FOR FUTURE USE.

THESE INSTRUCTIONS ARE INTENDED TO SUPPLEMENT GOOD GENERAL PRACTICES FOR THE VARIOUS STYLES OF PLASTEC FANS AND BLOWERS. DETAILED INSTRUCTIONS WILL BE PRESENTED SEPARATELY.

IT IS THE RESPONSIBILITY OF THE USER / PURCHASER TO ASSURE THE INSTALLATION, OPERATION, AND MAINTENANCE OF THIS EQUIPMENT IS CARRIED OUT BY EXPERIENCED AND QUALIFIED PERSONNEL IN THIS TYPE OF WORK.

CONTACT YOUR LOCAL REPRESENTATIVE FOR ANY FURTHER INFORMATION REQUIRED.

By using this product, Buyer, and Buyer's past, present, and future agents, representatives, attorneys, affiliates, heirs, executors, assigns and successors, and all other persons or entities associated therewith, agrees that it will indemnify and hold harmless Plastec Ventilation Inc., and all of its past, present, and future agents, representatives, principals, attorneys, affiliates, owners, parent corporations, subsidiaries, officers, directors, employees, assigns and successors, and all other persons or entities associated therewith, against any and all claims, demands, causes of action, liabilities, damages, costs, and judgments, including attorney's fees, hereafter brought or asserted by any person or entity arising out of the design, installation or use of any Product(s) manufactured by Plastec Ventilation Inc under this Agreement and in accordance with Buyer's Specifications except for any intentional acts of Manufacture or any of Manufacture's employees, agents or contractors.

No claims, representations or warranties, whether expressed or implied, are made by Plastec Ventilation Inc as to the safety, reliability, durability, and performance of any of our companies' products. Furthermore, our company accepts no liability whatsoever for the safety, reliability, durability, and performance of any of our companies' products.

1.1.2 Shipping & Receiving

All fans and blowers have been thoroughly inspected before shipment. Unless otherwise noted. All fans and blowers are tested and approved prior to shipment.

THE RECEIVER MUST NOTE ANY DAMAGE ON THE CARRIER'S BILL OF LADING AND FILE A CLAIM IMMEDIATELY WITH THE FREIGHT COMPANY.

Keep a record of all equipment received including inspection details and date of receipt. Contact your sales representative for replacement service.

Handle your equipment with caution using proper equipment and safety procedures.

1.1.3 Storage

Store fans in a clean, dry location prior to installation to protect against the weather and corrosive atmospheres. If it is necessary to store equipment outdoors, protect from the elements as much as possible. Keep equipment dry and clean. Cover inlets/outlets to prevent collection of moisture, dust, etc.



For equipment stored for extended periods of time (1 month), rotate motor bearings. Records of stored equipment should be kept to assure proper procedures.

1.2 Installation

Area where fan is installed should provide support for rigid mounting of the fan(s). Fans not supported properly will cause vibration that could cause damage or injury!

Use guy wires to secure roof mounted units, stacks and accessories where excessively windy conditions are prevalent.

CAUTION! Fans contain rotating parts and electrical service is used to operate.

Use appropriate safety precautions during Installation, Operation and Maintenance procedures.

WARNING! Do not install or operate fan in an environment or atmosphere where combustible or flammable materials, gases or fumes are present unless it is specifically designed for that type of environment. Explosion or fire can result.

Roof curbs for mounting of fans should be securely installed prior to fan installation. Fan should be firmly secured to roof curb to prevent vibration.

CAUTION! All electrical work must be done in accordance with local and /or national codes as applied. Work should be performed by qualified electricians.

WARNING! This product must be grounded.

DANGER! Make sure power is turned off and locked in the off position before installing, wiring or servicing fan.

CAUTION! Always check the supply voltage against the motor name plate voltage. Incorrect voltage can damage the motor and void the motor warranty.

WARNING! Keep all wiring clear of rotating or moving parts.

WARNING! Before starting the fan, turn the wheel to assure it rotates freely. **POWER MUST BE OFF DURING THIS OPERATION.**

CAUTION! Before operating any fan or blower, make sure any guards or protective devices required are in place for protection against injury.

1.3 Test & Start Procedures

WARNING: Do not insert your hands or arms in the fan while it is running.

It is highly recommended to insert an exhaust cap on the outlet and a six feet duct on the inlet flange to avoid accident or aspiration of hand, arm or clothes when the fan is running. Do not wear a scarf close to the fan when it is running to avoid accidental choking and potential death.

Disconnect power before servicing the unit. Make sure power is turned off and locked in the OFF position.

Check that fan/blower is securely attached to the mounting location and that the mounting location is also secure. This unit should not vibrate when operating! Check clearances and all mounting hardware and secure as required.

All fans have sealed for life ball bearings and do not require lubrication. Running the unit for 15 to 20 minutes will assure lubricant to thoroughly mix with the bearings and operate at optimum quietness.



When power is applied to the unit, check for proper rotation of fan wheel/impeller. Most motors allow for reverse rotation and if the fan wheel/impeller is moving in the wrong direction, air performance will be greatly affected. Reverse rotation for a prolonged period may cause motor damage that could void the warranty. Check the motor wiring diagram for proper wiring.

Electrical input check should be performed with fan properly loaded (pressure drop) to assure motor name plate amps are not exceeded. Never run a fan at free air.

Do not open the terminal box before tuning of the power.

Check fan RPM against motor name plate to verify correct performance.

The fans are factory tested and checked for vibration, so this type of balancing is not required. Vibration could be caused by rough handling during shipment, installation, and weak foundations. Correct as required.

1.4 Maintenance

Before performing any maintenance on the fan, be sure power is turned off and locked in the off position at the service entrance.

Ventilators should be carefully checked at least once a year. For critical or rugged applications, a routine check every two or three months is suggested.

All motors carry a one-year warranty from the date of shipment. For repairs within the warranty period, the motor must be taken to the motor manufacturer's authorized service dealer. Contact your representative for additional warranty details.

A periodic motor check should consist of spinning the motor shaft with the power off to be sure the motor turns freely and the bearings run smoothly.

The motor cooling fan and guard should also be maintained by checking and cleaning accumulated dust and debris.

The rotating wheel or propeller requires enhanced attention since materials in the air being handled can build up on blades to cause destructive vibration or weaken the structure of the propeller by corroding and /or eroding the blades. Regular inspection and corrective action at intervals determined by the severity of each application are essential to good service life and safety.

WARNING: Failure to comply with the above-mentioned maintenance schedule may result in catastrophic failure of equipment. Said failure may include physical damage, shrapnel, electrical short, equipment damage, overheating, fire, property damage and other dangerous conditions.

1.5 Motors

Periodic checks of voltage, frequency and current of a motor while in operation are recommended. Such checks assure the correctness of frequency and voltage applied to the motor and yield an indication of the fan load. Comparison of this data with previous data will give an indication of the fan performance. Any serious deviations could indicate a potential motor failure.

All motors carry a one-year warranty from date of shipment. For repairs within warranty period, the motor must be taken to the motor manufacturer's authorized service dealer. Contact your representative for additional warranty details.

A periodic motor check should consist of spinning the motor shaft with the power off so to be sure the motor turns freely and the bearings run smoothly.



Repair or replacement of motors is normally performed by a repair station authorized by the manufacturer. Contact your representative or the factory for locations nearest you. DO NOT ship motor to factory without specific authorization forms.

1.6 Warranty

This Blower Housing Assembly is warranted to be free from defects in material and workmanship for two years from date of original shipment. Any units or parts which prove to be defective and are reported during the warranty period will be replaced at our option when returned to our factory, transportation prepaid by the sender. Deterioration of wear by heat, abrasive action, chemicals, improper installation or operation or lack of normal maintenance shall not constitute defects, and are not covered by warranty. Transportation to and from the factory for warranty repairs is not covered under warranty and is the sole responsibility of the owner of the equipment.

The motor is warranted by the motor manufacturer for one year. If the motor becomes defective in the warranty period, it should be taken to the nearest authorized motor service station. If this is not done, the motor manufacturer will not warrant the motor. Call the factory for instructions if authorized service station is not known.

The manufacturer will not be responsible for any installation, removal or re-installation cost or any consequential damage resulting in failure to meet conditions of any warranty.

LIMITATION OF WARRANTY AND LIABILITY: This warranty does not apply to any product or parts which have failed as a result of faulty installation or abuse, or incorrect electrical connections or alterations, made by other, or use under abnormal operating conditions or misapplications of the products and parts.

The manufacturer will not approve for payment any repairs made outside its factory without prior written consent. The foregoing shall constitute our sole and exclusive warranty and our sole and exclusive liability and is in lieu of all other warranties whether written, oral, implied, or statutory. There are no warranties which extend beyond the description of the page hereof. Seller does not warranty that said goods and articles are merchantable quality or that they are fit for any particular purpose. The liability of seller on any claim of any kind, including negligence, for any loss or damage arising out of, or connected with, or resulting from the sale and purchase of the products and parts covered by this proposal, acknowledgment, order or from performance or breach of any contract pertaining to such sale or purchase, or from the design, manufacture, sale, delivery, resale, installation, technical direction of installation, inspection, repair, operation or use of any products or parts covered by this proposal, acknowledgment, order or furnished by seller shall, in no case exceed the price allocable to the product or parts thereof which give rise to the claim and shall terminate one (1) year after shipment of said products and parts.

In no event, whether as a result of breach of contract, or warranty or alleged negligence, defects, incorrect advise or other causes, shall seller be liable for special or consequential damages including, but not limited to, loss of profits or revenue, loss of use of the equipment or any associated equipment, cost of capital, cost of substitute equipment, facilities or services, down time costs or claims of customers of the purchaser for such damages. The manufacturer neither assumes nor authorizes any persons to assume for it any other liability in connection with the sale of its fan products and parts.

SAFETY ACCESSORIES WARNING: The responsibility for providing safety accessories for equipment supplied by the manufacturer is that of the installer and user of this equipment. The manufacturer sells its equipment with and without safety accessories, and accordingly it can supply such safety accessories upon receipt of order.

The user, in making its determination as to the appropriate safety accessories to be installed and any warning notices, should consider (1) the location of the installation, (2) the accessibility of employees and other persons to this equipment, (3) any adjacent equipment, (4) applicable building codes, and (5) requirements of the Federal Occupational Safety and Health Act.



Users and installers of this equipment should read, "RECOMMENDED SAFETY PRACTICES FOR AIR MOVING DEVICES" which is published by Air Movement and Control Association, 30 West University Drive, Arlington Heights, Illinois, 60004.

The invalidity or unenforceability of any particular provision in this document shall not affect the other provisions hereto, and this document shall be construed as though such invalid or unenforceable provisions were omitted.

1.7 Explosion Resistant products

The fans listed below are also available in Explosion Resistant version. They are compliant with all the international standards: NEC 500/505, ATEX (EN60079) and European directives (99/92/EC and 94/9/EC)



- | | | |
|--------------|------------|----------|
| - PLASTEC 15 | - STORM 10 | - JET 20 |
| - PLASTEC 20 | - STORM 12 | - JET 25 |
| - PLASTEC 25 | - STORM 14 | - JET 30 |
| - PLASTEC 30 | - STORM 16 | |
| - PLASTEC 35 | | |



For all Explosion Resistant certified PLASTEC products, additives are added to the polypropylene to reduce the risk of creating an electrical charge. The surface and volume resistivity is lower than $10^9\Omega$ as mentioned in the IEC60079-0 standard.

WARNING: FOR EXPLOSION RESISTANT FANS, ANY ASSEMBLY, DISASSEMBLY OR OTHER MODIFICATIONS, EVEN MINOR, ARE NOT RECOMMENDED AND MUST BE CARRIED OUT ONLY IN AGREEMENT ON THE RETURN BASIS WITH PLASTEC VENTILATION.

ATEX FAN INSTALLATIONS MUST BE PERFORMED BY ATEX APPROVED COMPANIES.

THE DEFINITION OF THE ZONE AND DIVISION (0, 1 OR 2 FOR GASES) IS THE RESPONSIBILITY OF THE USER, CUSTOMER, PROJECT MANAGER AND/OR SITE MANAGER. IN NO CASE CAN PLASTEC VENTILATION BE HELD RESPONSIBLE FOR A WRONG CHOICE OF ZONE.

IT IS HIGHLY RECOMMENDED TO USE MOTORS EQUIPED WITH A PTC OR PTO SENSOR WHEN OPERATING WITH A VARIABLE FREQUENCY DRIVE. IT IS THE CUSTOMER'S RESPONSIBILITY TO REQUEST IT WHEN ORDERING THE PRODUCTS.

WARNING: Elprom motors are not frequency inverter duty certified.

PLASTEC VENTILATION PRODUCTS ARE CERTIFIED ONLY FOR ZONE II GAZ.

EXPLOSION RESISTANT MARKING:

- NEC 500: CLASS I DIV II GROUP A,B,T4
- NEC 505: CLASS I ZONE II AEx d GROUP IIC T4
- ATEX : Ex II 3G Ex c GROUP IIC T4

1.8 Declaration of Conformity



**DECLARATION EU DE CONFORMITE
EU DECLARATION OF CONFORMITY
ATEX
N° 2019-06**

Nous /we: SEAT Ventilation, 70 Impasse Jean Mermoz, 09340 Verniolle, France
déclarons que les appareils mis sur le marché, pour des atmosphères explosibles, désignés ci-après :
*declare that the equipment about to be put on the market and for use in explosive atmospheres
described below :*

Types de ventilateurs : Seat, Jet, Storm
Fan types

Pour Gaz/For Gas : CE 0081 Ex II 3 G,
EEx c IIC T4

satisfont : - aux dispositions de la directive 94/9 CE (jusqu'au 19 avril 2016 / *the provisions of
directive 94/9 EC (until April 19th, 2016)*)
- aux dispositions de la directive 2014/34/UE (à partir du 20 avril 2016 / *the provisions of
directive 2014/34/UE (from 30 April 2016)*)
- au décret 96-1010 annexe 8
- à la série de tests prescrite par la norme EN 13463-1 (2002), effectuée par le laboratoire
L.C.I.E. (n°0081) / *tests required by EN 13463 standard and implemented by L.C.I.E. laboratory.*
- à la Norme EN 14986 (2007) Conception des ventilateurs pour Atmosphères Explosives

Modifié : - Tests référence SN/04-SEAT-ITA/ATEX du (of) 2004/03/22

Les produits sont conformes aux Directives suivantes :
The products are in conformity with provisions of the following Council Directives :
Directive 2014/34/EU et (and) 2011/65/EU

sous réserve d'une utilisation conforme à leur destination et/ou d'une installation conforme aux
normes en vigueur et/ou aux recommandations du constructeur.
*Subject to use for the purpose for which they were designated and/or installed in accordance with
standards in force and/or with the manufacturer's recommendations.*

Le produit désigné a été conçu, fabriqué et contrôlé dans le cadre d'un système d'assurance qualité
ISO 9002.
*The said product has been designed, manufactured and controlled within the guidelines of a quality
insurance system in accordance with ISO 9002.*

Nos appareils sont adaptés pour fonctionner à des températures ambiantes situées entre -22°C et +40°C.
La présente déclaration de conformité est établie sous la seule responsabilité du fabricant.

Verniolle, le 16 juin 2019

Jean-Jacques GAUDIOT
President

Année d'apposition du marquage CE : 2008
Year of affixing CE marking :





2 PLASTEC utility and Storm Blowers

2.1 Disassembly Instructions

Before beginning these instructions, place this fan on a bench or tabletop that can support its weight.

1. Remove Torx head screws from the motor plate. (These screws require a T-20 bit.)
2. Lift the assembly clear of the fan housing. Set the fan housing aside.
3. Use a thin flat head screwdriver to pop the black hub cap off the bushing. It may be necessary to reach between the blades of the impeller to do this. (Be careful not to damage the impeller during this step.)
4. Remove the shaft bolt, lock washer and washer. The bolt will be 8mm, 10mm or 13mm.
5. Use a gear puller to remove the impeller from the shaft. Always use the bushing as the pulling point. Pulling on the blades or rim of the impeller will cause irreparable damage.
6. Use a 10mm or 13mm socket to remove the four bolts securing the motor plate to the C-face.

(See Illustrations)

2.2 Reassembly Instructions

Before beginning these instructions, place this fan on a bench or tabletop that can support its weight.

1. Stand the motor on end, so that the shaft is pointing vertically.
2. Set the motor plate onto the C-face and align bolt holes. If motor plate does not fit flush on the C-face, use a small hammer or dead blow mallet to seat the plate onto the rabbet. You should not need much force to seat the plate. Secure the motor plate with four bolts, lock washers and washers.
3. Check the fit of the impeller bushing on the motor shaft. If it slides on easily, then push it onto the shaft and tap to seat it on the shaft shoulder. If it is a tight fit, lubricate the inside of the bushing with 3-in-1 oil or a similar product. Set the impeller on top of the shaft so it sits level. Use a driving rod and mallet, on bushing only, to drive the impeller onto the shaft until it touches the shoulder. Do not hit with excessive force or the bearings may be damaged. Remove any debris that was cut from the inside of the bushing. If there is a gap between the tip of the shaft and the top of the bushing, fill it with stainless steel washer(s).
4. Secure the impeller on the shaft with supplied bolt, lock washer and washer.
5. Cover the bushing with the hub cap and use a mallet to seat it properly. It may be necessary to cut out the raised ring on the inside of the hub cap with a box knife.
6. Select the orientation of the fan housing. There are eight possible orientations.
7. Remember, if the fan is being installed in a weather hood, the motor will be upside down. Use eight Torx head screws to secure the motor assembly to the fan housing. Inspect visually and test electrically before installing the fan.

(See Illustrations)



2.3 Illustration: Plastec Utility and Storm Blower

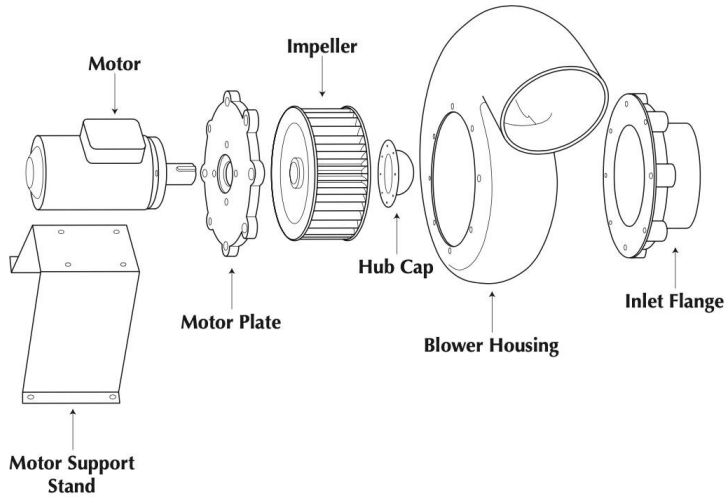

TYPICAL ROOF TOP INSTALLATION FOR PLASTEC/STORM UTILITY BLOWER

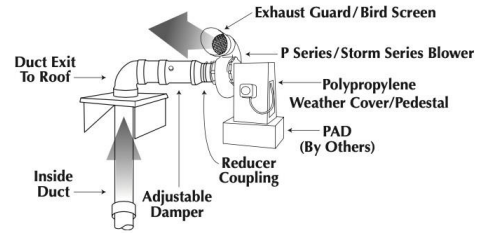

TYPICAL INSTALLATION FOR PLASTEC BLOWER WITH ROOF UNIT OPTION

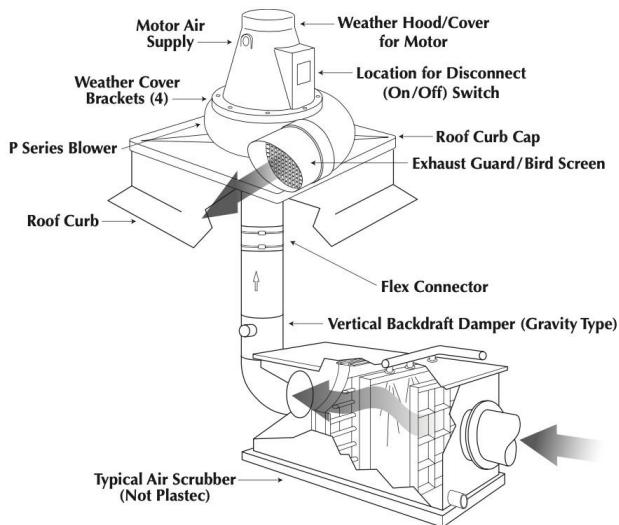

MOUNTING PLASTEC SERIES AND STORM SERIES TO SUPPORT STAND

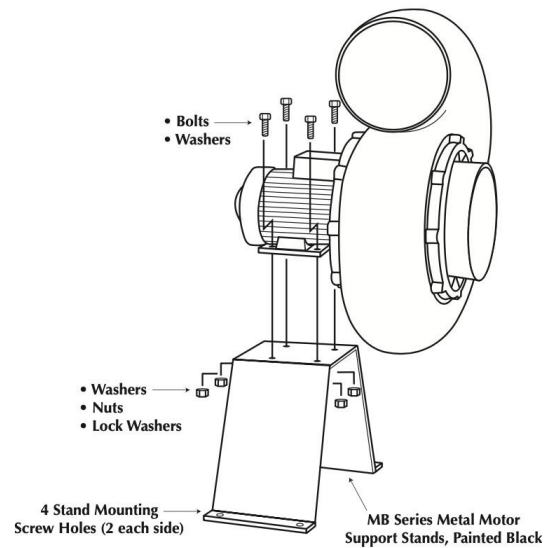

2.4 Illustrations: Attachment of PLASTEC Fan to Weather Hood

1. The motor feet should point vertically upwards for attachment to the underside of the hood top. Ensure that the fan discharge is correctly orientated in relation to the motor feet.
2. It is recommended that the motor is connected to the disconnect switch prior to assembly of motor and weather hood, otherwise access to the terminals may be difficult.
3. Insert the four bolts into the holes in the weather cover. Prevent them from falling out by fitting the barbed washers.
4. Secure weather hood to the motor by means of nuts, large washers and lock washers. This is best accomplished by placing the fan housing on a horizontal surface with the motor shaft vertical, then introduce the holes in the hood to the bolts you have fitted to the motor feet.
5. Ensure that the weather hood is installed in an up-right position and that the drain holes in the base panel are clear.

Rotation and Discharge for Centrifugal Fans

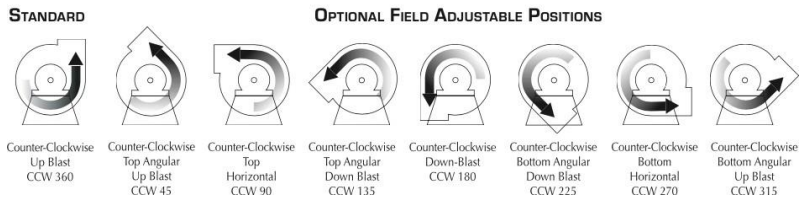

Notes:

- (1) Direction of rotation is determined from the drive side of fan.
Standard position is up-blast CCW 360.
- (2) On single inlet fans, drive side is always considered as the opposite fan inlet.

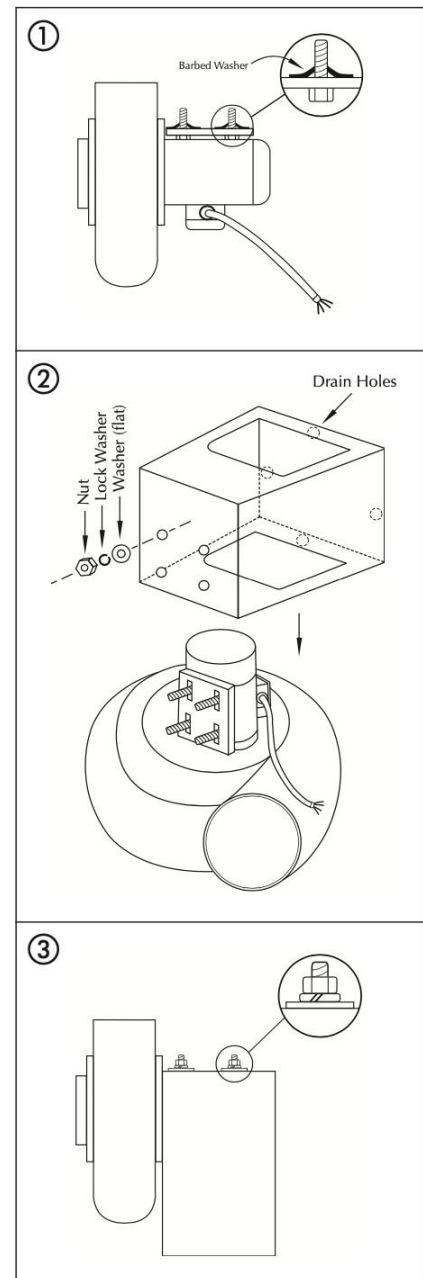



3 PLASTEC PSS Series Stainless Steel Utility Blowers

3.1 Disassembly Instructions

Before beginning these instructions, place this fan on a bench or table top that can support its weight. For tool size see illustration.

1. Remove Hex cap screws from the motor plate. (Be careful not to damage the impeller during this operation.)
2. Lift the assembly clear of the fan housing. Set the fan housing aside.
3. Remove the hub cap and teflon gasket.
4. Loosen the shaft locking screws (hub).
5. Use a gear puller to remove the impeller from the shaft. Always use the bushing as the pulling point. Pulling on the blades or rim of the impeller will cause irreparable damage.
6. Remove the 4 motor plate bolts to remove the motor plate from the motor.
7. Remove the motor support stand if required by this operation.

(See Illustrations)

NOTE: Any new assembly parts or mounting hardware sourced must be 316 Stainless Steel

3.2 Reassembly instructions

Before beginning these instructions, place this fan on a bench or table top that can support its weight.

1. Stand the motor on end, so that the shaft is pointing vertically.
2. Set the motor plate onto the C-face and align bolt holes. If motor plate does not fit flush on the C-face, use a small hammer or dead blow mallet to seat the plate onto the rabbet. You should not need much force to seat the plate. Secure the motor plate with four bolts, lock washers and washers. Apply the teflon gasket between the motor plate and housing.
3. Check the fit of the impeller bushing on the motor shaft. If it slides on easily, then push it onto the shaft and tap to seat it on the shaft. If it is a tight fit, lubricate the inside of the bushing with 3-in-1 oil or a similar product. Set the impeller on top of the shaft so it sits level. Use a driving rod and mallet, on bushing only, to drive the impeller onto the shaft until it is even with the end of the motor shaft. Do not hit with excessive force or the bearings may be damaged.
4. Secure the impeller on the shaft with supplied locking screws (2).
5. Cover the bushing with the hub cap gasket and hub cap. Lock in place with two screws supplied.
6. Select the orientation of the fan housing. There are eight possible orientations.
7. Remember, if the fan is being installed in a weather hood, the motor will be upside down. Use eight Hex head screws to secure the motor assembly to the fan housing. Inspect visually and test electrically before installing the fan. Ensure the teflon gasket is in place.

(See Illustrations)

NOTE: Any new assembly parts or mounting hardware sourced must be 316 Stainless Steel.

3.3 Illustration: PSS Series – PSS20 and PSS35

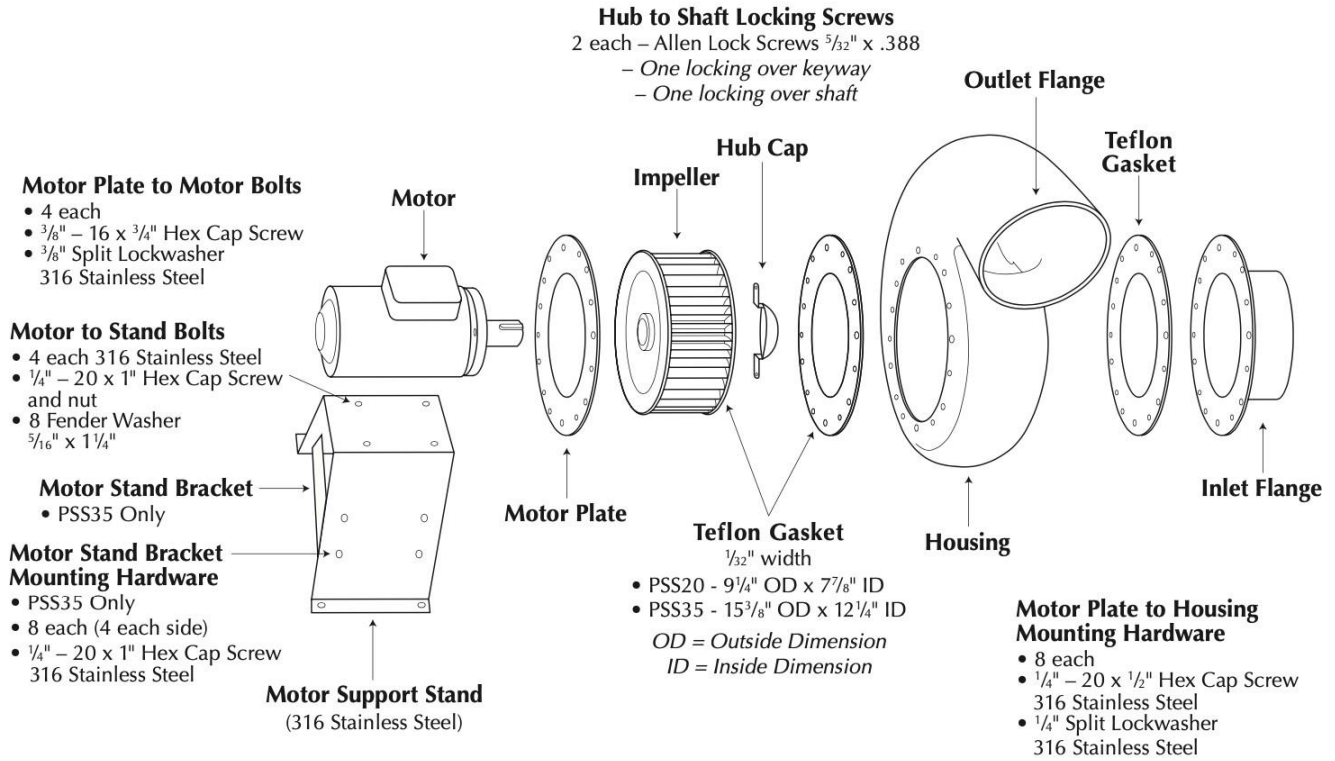

MOUNTING PSS SERIES TO SUPPORT STAND

TYPICAL ROOF TOP INSTALLATION

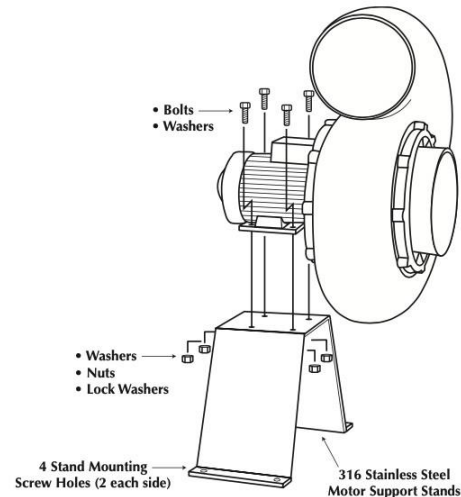
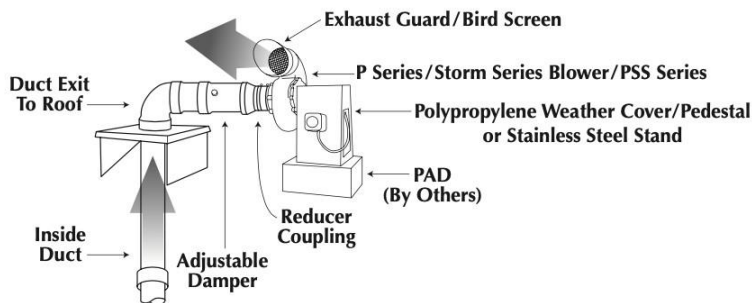



4 PLASTEC JET Series

4.1 Disassembly Instructions

Before beginning these instructions, place this fan on a bench or table top that can support its weight.

1. Disconnect the fan from its power source.
2. Open the switch box. Take note of the wire positions before removing them from the wiring terminal.
3. Unscrew the plastic locknut from the liquid tight fitting on top of the switch box and the one from the face of the weather cover.
4. Gently pull the conduit and cable out of the top of the switch box and pull the conduit off the cable.
5. Push a short length of cable back into the weather cover. This provides slack for lifting the weather cover off the manifold.
6. Remove the six or eight Phillips head screws from the base ring of the weather cover.
7. Lift the weather cover up and over the top of the manifold, being careful not to damage the cable.
8. If the motor is being replaced, be sure to retrieve the cable and strain relief connector from the wiring box. Take note of the orientation of the wiring positions before removing the cable.
9. Take note of the orientation of the motor as it sits in the fan body. This is important for the reassembly procedure.
10. Remove eight Torx head screws from the motor plate. Lift the motor assembly out of the fan body. Stand on the cooling fan end of the motor. Refer to step #3 of the utility blower disassembly sheet.

(See Illustrations)

4.2 Reassembly Instructions

Before beginning these instructions, place this fan on a bench or table top that can support its weight.

1. Complete steps one through five of the Utility Blower assembly procedure.
2. Set the motor plate into the fan body in the same orientation as it was before being removed.
3. Secure the motor assembly to the fan body with eight Torx head screws.
4. Remove the lid from the wiring box. Install the strain relief connector and wire according to the motors and wiring diagram. Close the wiring box.
5. Slide the manifold onto the outlet of the fan body. If it is a tight fit, use a rubber mallet to tap it into position. Use careful strikes to avoid damaging the fan body or manifold. Do not use any adhesive or hardware to secure the manifold. Make sure the drain hole in the manifold is clear from the fan housing outlet.
6. Hold the weather cover over the fan assembly and feed the cable through the liquid tight fitting, from inside to out, while lowering the weather cover over the fan assembly.
7. Push the weather cover down past the fan body so it is seated in the ring on the colored base. Pull any additional slack out of the power cable. Align the holes around the base of the weather cover and the colored ring. Secure it in place with 6 or 8 Phillips head screws.
8. Feed the power cable through the conduit and fit the conduit into the liquid tight fitting in the weather cover. Screw the plastic lock nut onto this liquid tight fitting. Slide the other locknut onto the conduit and make sure it is oriented correctly.
9. Feed the power cable through the liquid tight fitting on top of the switch box and fit positions as before. Screw the second locknut onto the liquid tight fitting. Reconnect the power supply and close the switch box.

(See Illustrations)



4.3 Illustration: Jet Series

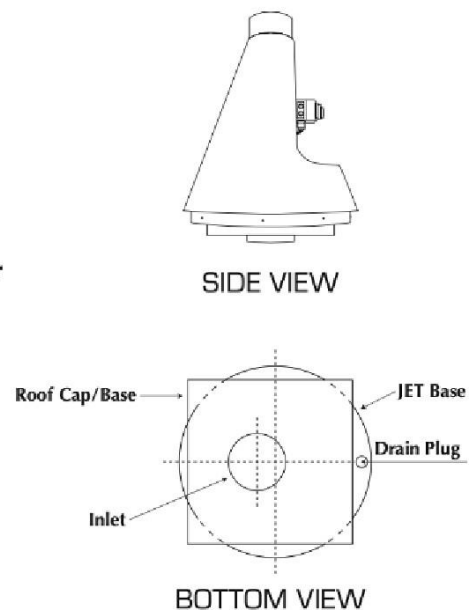
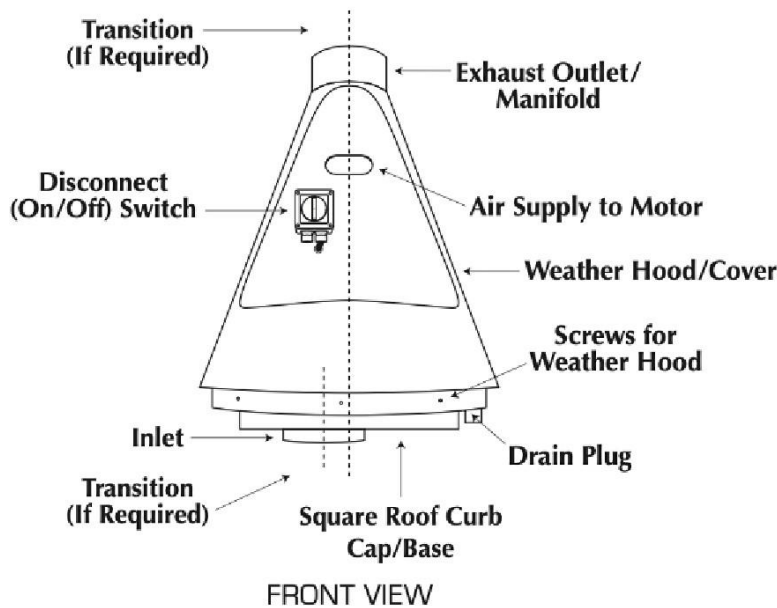
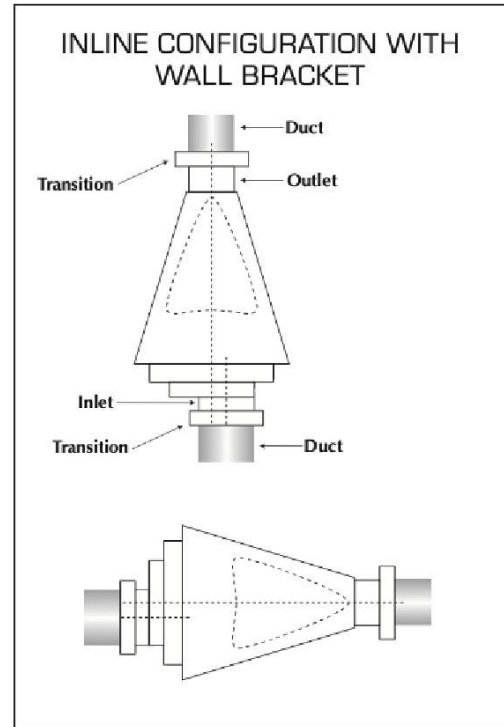
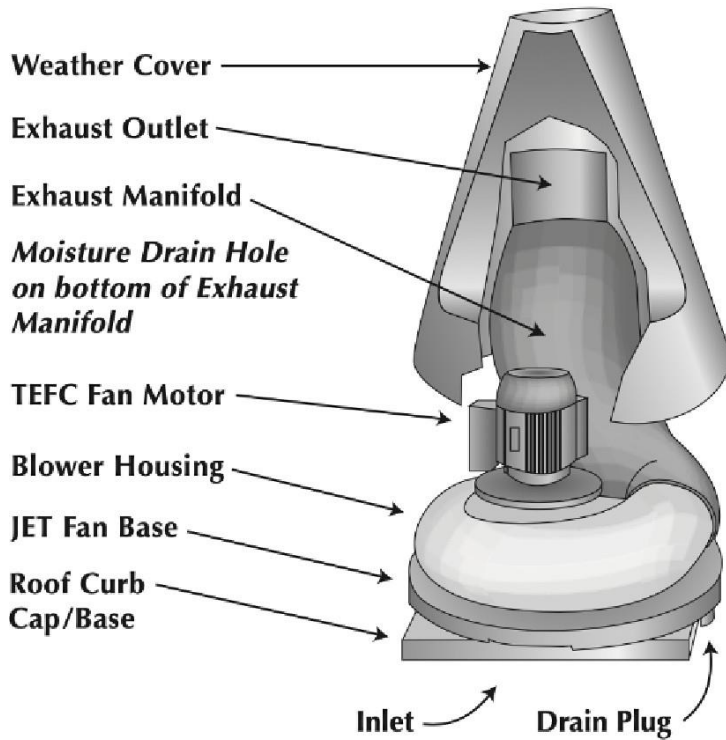

5 Roof Unit Kits

5.1 Roof Unit 15 – Roof Unit 30 Kit Assembly



1. Components of Roof Kit: Roof Curb Cap, Motor Cap, Cap Bracket, Exhaust Guard



2. Place the cap bracket on the motor with the screwing inserts upwards.



3. Fix the motor flange.



4. Place the O-ring seal.



5. Place the impeller.



6. Push in the impeller.



7. Screw the hub cap on the motor shaft.



8. Install the hub cap.



9. Place the roof curb cap O-ring seal.



10. Place the roof curb cap on the housing.



11. Screw the roof curb cap to the housing.



12. Turn over the housing.
Reinforce the base before placing the roof curb cap to support.



13. Place the motor/impeller part.



14-17. Screw the motor flange and the cap bracket on the housing indicated in the pictures.



15.

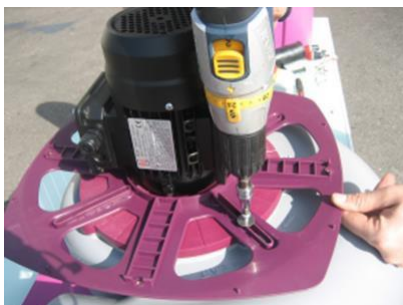

16.



17.



18. Do the correct wiring between the switch and the motor, respecting tension.

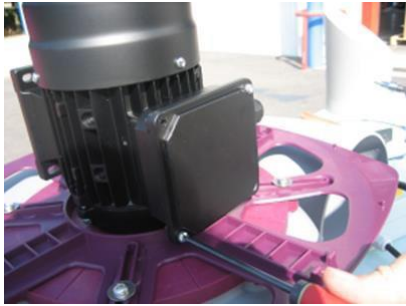

19. Screw back on the terminal box lid.



20-21. Place the motor cap and secure with screws.



21.



22-24. Attach switch with screws on the flat side of the motor cap.



23.



24.



25. Place the exhaust cap on the outlet and attach with 4 screws.



26. Finished Assembly.

5.2 Roof Unit 35 Kit Assembly

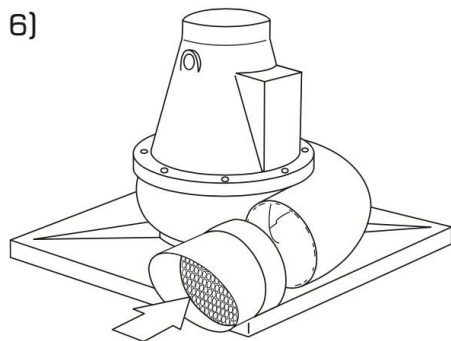
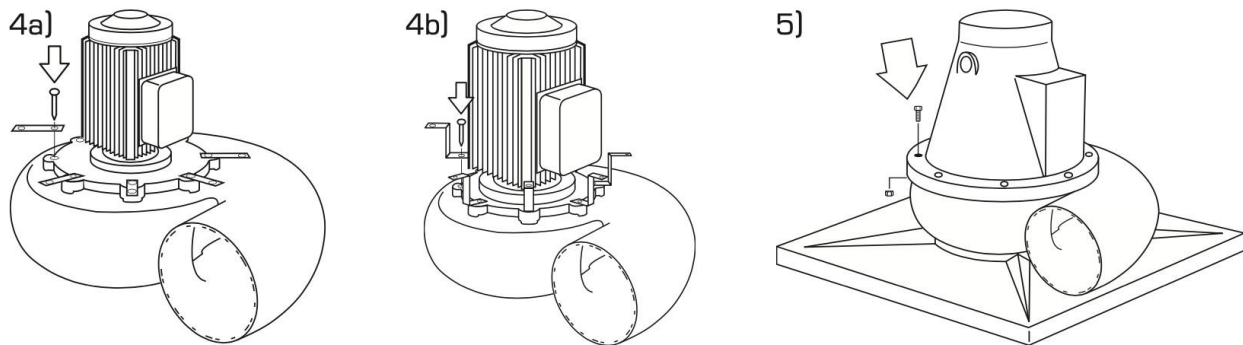
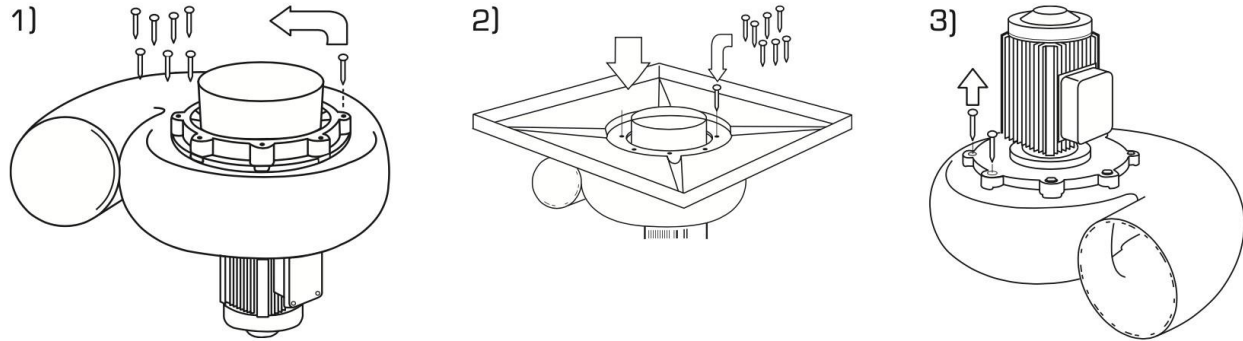

- 1) Remove inlet screws.
- 2) Place roof cap on inlet and secure with inlet screws.
- 3) Remove applicable motor plate screws where brackets fit.
- 4) [a & b] Attach brackets using motor plate screws.
- 5) Attach motor weather cover to brackets using bolts, washers and nuts. (After installing electrical cable.)
- 6) Complete assembly by installing outlet guard/bird screen using screws.

6 Electrical wiring

6.1 General Precautions

WARNING! This equipment should be installed, adjusted, and serviced by qualified electrical maintenance personnel familiar with the construction and operation of the equipment and the hazards involved. Failure to observe this precaution could result in property damage and/or serious bodily injury, including death.

HIGH VOLTAGE! Hazard of electrical shock. Disconnect incoming power before working on this control.

WARNING! Wait at least five (5) minutes after turning off the input power supply before performing maintenance or an inspection. Otherwise, there is the danger of electric shock.

CAUTION! Proper grounds, disconnecting devices and other safety devices and their location are the responsibility of the user and are not provided by Plastec Ventilation Inc.

WARNING! For equipment protection, install a ground leakage type breaker with a fast response circuit capable of handling large currents. The ground fault protection circuit is not designed to protect against personal injury.

6.2 Diagram

6.2.1 TechTop wiring

Three Phase motor

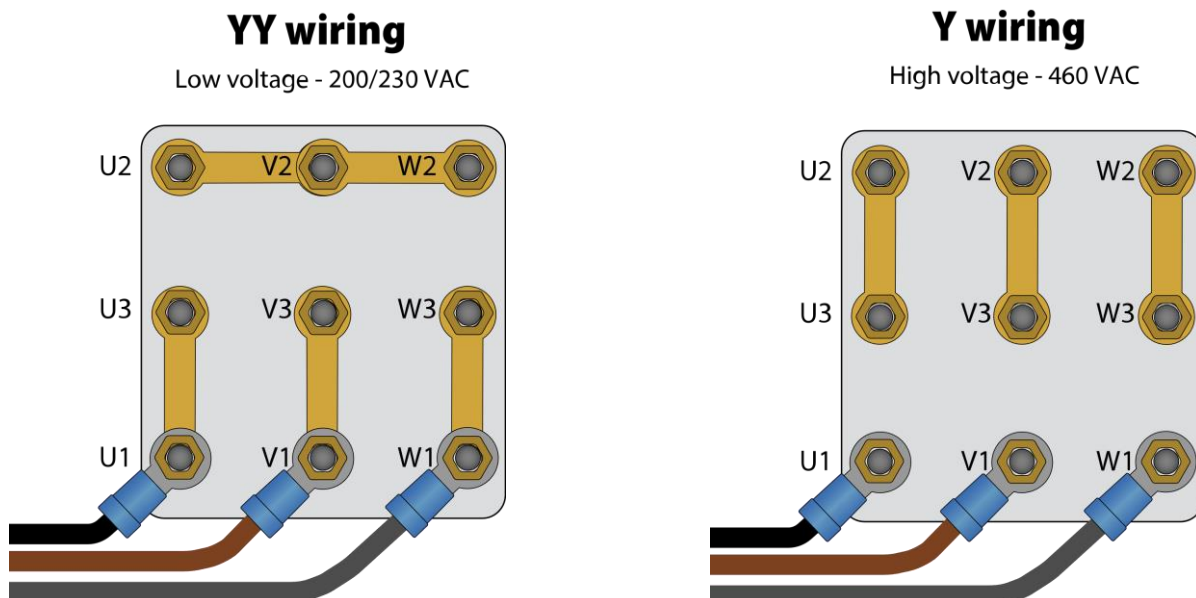

Single Phase motor

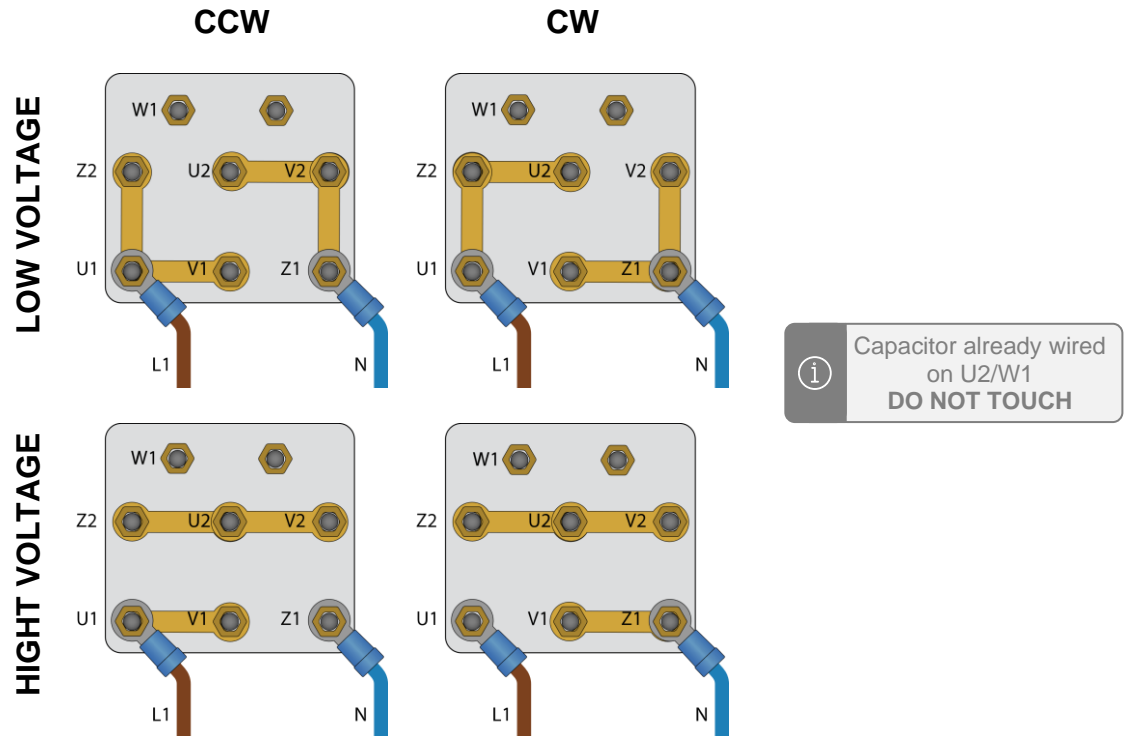

6.2.2 Elprom wiring

Three Phase motor

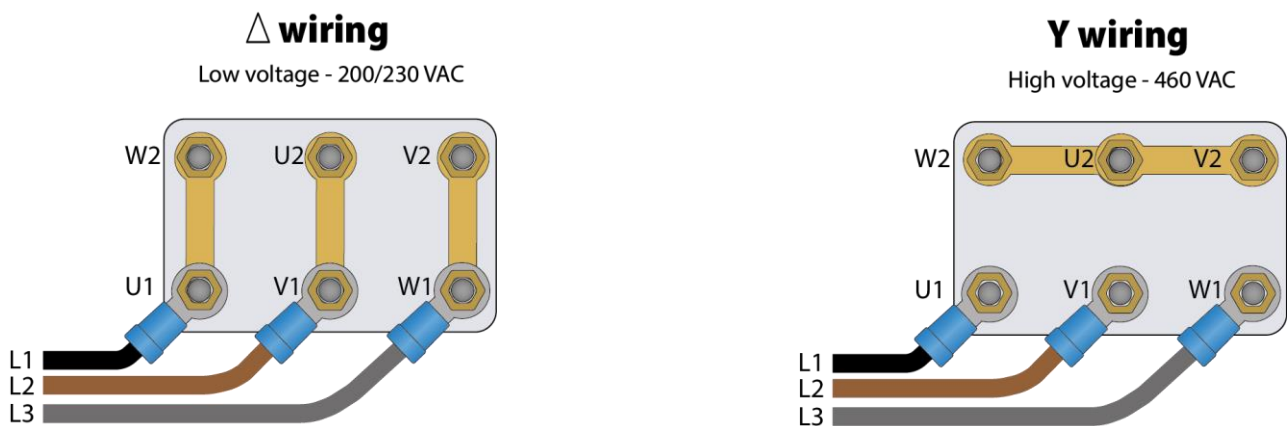



Single Phase motor

