

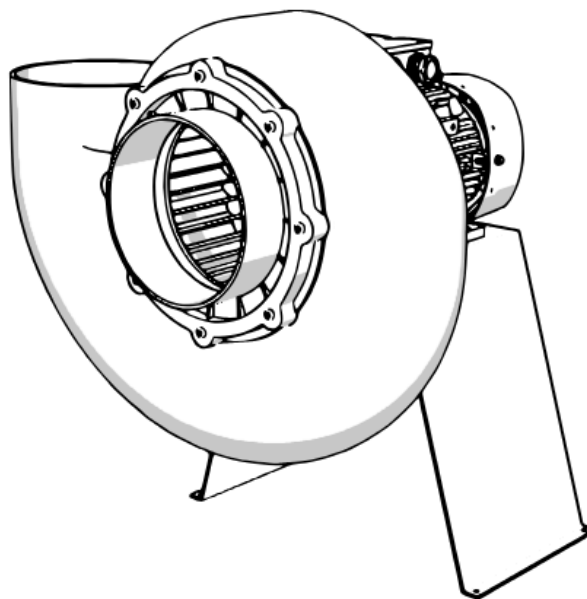

PLASTEC Series Installation, Operation and Maintenance Manual

March 2024





1	General Information	3	9.2	Weather hood	35
1.1	Introduction.....	3	9.2.1	Installation	35
1.2	Shipping and Receiving	3	9.3	Vibration Isolators	38
1.3	Storage.....	4	9.3.1	Motor Support Stand Installation	38
2	Safety Information.....	4	9.3.2	Weather hood Installation	41
2.1	Safety Warnings	4	9.4	Roof Unit Kit.....	44
2.2	Personal Protective Equipment.....	5	9.4.1	Installation	44
3	Regulatory Compliance.....	5	9.4.2	Roof Curb Installation	51
3.1	Certifications.....	5	9.4.3	Wall Bracket Installation.....	53
4	Explosion Resistant Products.....	5	9.5	Speed Nozzle.....	56
5	Warranty	7	9.5.1	Installation	56
6	Description.....	8	10	Test & Start Procedures.....	58
6.1	Intended Use	8	10.1	Test & Normal Start Procedures	58
6.2	Technical Data	9	10.2	VFD Start Procedures	59
6.3	Dimensions.....	9	11	Troubleshooting/Maintenance/Repair	59
6.3.1	PLASTEC Series.....	9	11.1	Maintenance Schedule.....	60
6.3.2	PLASTEC 50.....	10	11.2	Common Questions	62
6.4	Expanded View.....	11	11.3	Troubleshooting Procedures	63
6.4.1	PLASTEC Series.....	11			
6.4.2	PLASTEC 50.....	11			
7	Installation	12			
7.1	Handling Information.....	12			
7.1.1	Rigging Instructions.....	12			
7.2	Installation Orientations	13			
7.3	PLASTEC Series	13			
7.3.1	Disassembly Instructions.....	13			
7.3.2	Assembly/Reassembly Instructions	17			
7.3.3	Counterclockwise and Clockwise Conversions.....	22			
8	Electrical Installation/Wiring	29			
8.1	Motors	30			
8.2	Single Phase Motors.....	30			
8.2.1	Techtop	30			
8.2.2	Elprom/Orange1	31			
8.3	Three Phase Motors	32			
8.3.1	Techtop	32			
8.3.2	Elprom/Orange1	32			
9	Accessories	33			
9.1	Motor Support Stand.....	33			
9.1.1	Installation.....	33			



1 General Information

1.1 Introduction

DO NOT INSTALL, USE OR OPERATE THIS EQUIPMENT UNTIL THIS MANUAL HAS BEEN FULLY READ AND UNDERSTOOD. RETAIN THESE INSTRUCTIONS FOR FUTURE USE.

THESE INSTRUCTIONS ARE INTENDED TO SUPPLEMENT GOOD GENERAL PRACTICES FOR THE VARIOUS STYLES OF PLASTEC FANS AND BLOWERS. DETAILED INSTRUCTIONS WILL BE PRESENTED SEPARATELY.

IT IS THE RESPONSIBILITY OF THE USER / PURCHASER TO ASSURE THE INSTALLATION, OPERATION, AND MAINTENANCE OF THIS EQUIPMENT IS CARRIED OUT BY EXPERIENCED AND QUALIFIED PERSONNEL IN THIS TYPE OF WORK.

CONTACT YOUR LOCAL REPRESENTATIVE FOR ANY FURTHER INFORMATION REQUIRED.

By using this product, Buyer, and Buyer's past, present, and future agents, representatives, attorneys, affiliates, heirs, executors, assigns and successors, and all other persons or entities associated therewith, agrees that it will indemnify and hold harmless Plastec Ventilation Inc., and all of its past, present, and future agents, representatives, principals, attorneys, affiliates, owners, parent corporations, subsidiaries, officers, directors, employees, assigns and successors, and all other persons or entities associated therewith, against any and all claims, demands, causes of action, liabilities, damages, costs, and judgments, including attorney's fees, hereafter brought or asserted by any person or entity arising out of the design, installation or use of any Product(s) manufactured by Plastec Ventilation Inc under this Agreement and in accordance with Buyer's Specifications except for any intentional acts of Manufacture or any of Manufacture's employees, agents or contractors.

No claims, representations or warranties, whether expressed or implied, are made by Plastec Ventilation Inc as to the safety, reliability, durability, and performance of any of our companies' products. Furthermore, our company accepts no liability whatsoever for the safety, reliability, durability, and performance of any of our companies' products.

1.2 Shipping and Receiving

All fans and blowers have been thoroughly inspected before shipment. Unless otherwise noted. All fans and blowers are tested and approved prior to shipment.



THE RECEIVER MUST NOTE ANY DAMAGE ON THE CARRIER'S BILL OF LADING AND FILE A CLAIM IMMEDIATELY WITH THE FREIGHT COMPANY.

Keep a record of all equipment received including inspection details and date of receipt. Contact your sales representative for replacement service.

Handle your equipment with caution using proper equipment and safety procedures

1.3 Storage

Store fans in a clean, dry location prior to installation to protect against the weather and corrosive atmospheres. If it is necessary to store equipment outdoors, protect it from the elements as much as possible. Keep equipment dry and clean. Cover inlets/outlets to prevent collection of moisture, dust, etc.

For equipment stored for extended periods of time (1 month), rotate motor bearings. Records of stored equipment should be kept to assure proper procedures.

2 Safety Information

2.1 Safety Warnings

CAUTION! Fans contain rotating parts and electrical service is used to operate.

Use appropriate safety precautions during Installation, Operation and Maintenance procedures.

WARNING! Do not install or operate fan in an environment or atmosphere where combustible or flammable materials, gases or fumes are present unless it is specifically designed for that type of environment. Explosion or fire can result.

Roof curbs for mounting of fans should be securely installed prior to fan installation. Fan should be firmly secured to roof curb to prevent vibration.

CAUTION! All electrical work must be done in accordance with local and /or national codes as applied. Work should be performed by qualified electricians.

WARNING! This product must be grounded.

DANGER! Make sure power is turned off and locked in the off position before installing, wiring, or servicing fan.

CAUTION! Always check the supply voltage against the motor name plate voltage. Incorrect voltage can damage the motor and void the motor warranty.

WARNING! Keep all wiring clear of rotating or moving parts.

WARNING! Before starting the fan, turn the wheel to assure it rotates freely. **POWER MUST BE OFF DURING THIS OPERATION.**



CAUTION! Before operating any fan or blower, make sure any guards or protective devices required are in place for protection against injury.

WARNING! Do not insert your hands or arms in the fan while it is running.

WARNING! Ensure that all belongings and clothing items are secured if working near blower while it is running. Failure to do will result in blower sucking in said items.

CAUTION! Blower motor may become hot during operation. Do not touch blower motor without proper personal protective equipment (PPE) during operation.

WARNING! Ensure that the blower is installed in a well-ventilated area. Do not insulate motor. Insulating motor can result in failure of blower and fire.

2.2 Personal Protective Equipment

When working in the vicinity of the fan or performing maintenance on the fan, wear the proper personal protective equipment. Personal protective equipment (PPE) includes the following:

- Goggles or Eye-protection
- Hearing Protection
- Helmet or Head Protection
- Protective Working Clothes
- Protective Working Shoes
- Protective Working Gloves

3 Regulatory Compliance

3.1 Certifications

PLASTEC Ventilation certifies that the PLASTEC Series shown herein is licensed to bear the AMCA Seal. The ratings shown are based on tests and procedures performed in accordance with AMCA Publication 211 and AMCA Publication 311 and comply with the requirements of the AMCA Certified Ratings Program.

4 Explosion Resistant Products

The fans listed below are also available in Explosion Resistant version. They are compliant with all the international standards: NEC 500/505, ATEX (EN60079) and European directives (99/92/EC and 94/9/EC)

PLASTEC 15	-	STORM 10	-	JET 20
PLASTEC 20	-	STORM 12	-	JET 25





PLASTEC 25 - STORM 14 - JET 30
PLASTEC 30 - STORM 16
PLASTEC 35 - STORM 18
PLASTEC 50

For all Explosion Resistant certified PLASTEC products, additives are added to the polypropylene to reduce the risk of creating an electrical charge. The surface and volume resistivity is lower than $10^9\Omega$ as mentioned in the IEC60079-0 standard.

WARNING: FOR EXPLOSION RESISTANT FANS, ANY ASSEMBLY, DISASSEMBLY OR OTHER MODIFICATIONS, EVEN MINOR, ARE NOT RECOMMENDED AND MUST BE CARRIED OUT ONLY IN AGREEMENT ON THE RETURN BASIS WITH PLASTEC VENTILATION.

FAN INSTALLATIONS IN HAZARDOUS LOCATIONS MUST BE PERFORMED BY ATEX APPROVED COMPANIES.

THE DEFINITION OF THE ZONE AND DIVISION (0, 1 OR 2 FOR GASES) IS THE RESPONSIBILITY OF THE USER, CUSTOMER, PROJECT MANAGER AND/OR SITE MANAGER. IN NO CASE CAN PLASTEC VENTILATION BE HELD RESPONSIBLE FOR A WRONG CHOICE OF ZONE, DIVISION, OR GROUP.

IT IS HIGHLY RECOMMENDED TO USE MOTORS EQUIPED WITH A PTC OR PTO SENSOR WHEN OPERATING WITH A VARIABLE FREQUENCY DRIVE. IT IS THE CUSTOMER'S RESPONSIBILITY TO REQUEST IT WHEN ORDERING THE PRODUCTS.

WARNING: Elprom motors are not frequency inverter duty certified.

PLASTEC VENTILATION PRODUCTS ARE CERTIFIED ONLY FOR ZONE II GAZ.

EXPLOSION RESISTANT MARKING:

NEC 500: CLASS I DIV II GROUP A,B,T4

NEC 505: CLASS I ZONE II AEx d GROUP IIC T4

ATEX : Ex II 3G Ex c GROUP IIC T4



5 Warranty

This Blower Housing Assembly is warranted to be free from defects in material and workmanship for two years from date of original shipment. Any units or parts which prove to be defective and are reported during the warranty period will be replaced at our option when returned to our factory, transportation prepaid by the sender. Deterioration of wear by heat, abrasive action, chemicals, improper installation or operation or lack of normal maintenance shall not constitute defects, and are not covered by warranty. Transportation to and from the factory for warranty repairs is not covered under warranty and is the sole responsibility of the owner of the equipment.

The motor is warranted by the motor manufacturer for one year. If the motor becomes defective in the warranty period, it should be taken to the nearest authorized motor service station. If this is not done, the motor manufacturer will not warrant the motor. Call the factory for instructions if authorized service station is not known.

The manufacturer will not be responsible for any installation, removal or re-installation cost or any consequential damage resulting in failure to meet conditions of any warranty.

LIMITATION OF WARRANTY AND LIABILITY: This warranty does not apply to any product or parts which have failed as a result of faulty installation or abuse, or incorrect electrical connections or alterations, made by other, or use under abnormal operating conditions or misapplications of the products and parts.

The manufacturer will not approve for payment any repairs made outside its factory without prior written consent. The foregoing shall constitute our sole and exclusive warranty and our sole and exclusive liability and is in lieu of all other warranties whether written, oral, implied, or statutory. There are no warranties which extend beyond the description of the page hereof. Seller does not warranty that said goods and articles are merchantable quality or that they are fit for any particular purpose. The liability of seller on any claim of any kind, including negligence, for any loss or damage arising out of, or connected with, or resulting from the sale and purchase of the products and parts covered by this proposal, acknowledgment, order or from performance or breach of any contract pertaining to such sale or purchase, or from the design, manufacture, sale, delivery, resale, installation, technical direction of installation, inspection, repair, operation or use of any products or parts covered by this proposal,

acknowledgment, order or furnished by seller shall, in no case exceed the price allocable to the product or parts thereof which give rise to the claim and shall terminate one (1) year after shipment of said products and parts.

In no event, whether as a result of breach of contract, or warranty or alleged negligence, defects, incorrect advise or other causes, shall seller be liable for special or consequential damages including, but not limited to, loss of profits or revenue, loss of use of the equipment or any associated equipment, cost of capital, cost of substitute equipment, facilities or services, down time costs or claims of customers of the purchaser for such



damages. The manufacturer neither assumes nor authorizes any persons to assume for it any other liability in connection with the sale of its fan products and parts.

SAFETY ACCESSORIES WARNING: The responsibility for providing safety accessories for equipment supplied by the manufacturer is that of the installer and user of this equipment. The manufacturer sells its equipment with and without safety accessories, and accordingly it can supply such safety accessories upon receipt of order.

The user, in making its determination as to the appropriate safety accessories to be installed and any warning notices, should consider (1) the location of the installation, (2) the accessibility of employees and other persons to this equipment, (3) any adjacent equipment, (4) applicable building codes, and (5) requirements of the Federal Occupational Safety and Health Act.

Users and installers of this equipment should read, "RECOMMENDED SAFETY PRACTICES FOR AIR MOVING DEVICES" which is published by Air Movement and Control Association, 30 West University Drive, Arlington Heights, Illinois, 60004.

The invalidity or unenforceability of any particular provision in this document shall not affect the other provisions hereto, and this document shall be construed as though such invalid or unenforceable provisions were omitted.

6 Description

6.1 Intended Use

The PLASTEC series and PLASTEC XP series blowers were developed and built for the intended purpose of being used in ventilation systems. These blowers are intended to be used for extracting air from ventilation systems, especially for ventilation systems with the presence of corrosive gases/vapors. The PLASTEC series and PLASTEC XP series blowers are built as chemical and corrosion resistant fans.

The PLASTEC XP series blowers are intended to be used for conveying air or explosive atmospheres.



6.2 Technical Data

Sub Series	Min. Flow (cfm)	Max. Flow (cfm)	Min. Static (in. Wg)	Max. Static (in. Wg)	Max. Inlet Temp (F)	Min. Operating Temp (F)	Acoustic dB(A)
Plastec 15	11	600	0.1	2.55	140	-39	54
Plastec 20	30	1200	0.15	5.8	140	-39	65
Plastec 25	100	2100	0.25	8.0	140	-39	73
Plastec 30	270	3400	0.30	3.1	140	-39	78
Plastec 35	500	6400	0.4	5.45	140	-39	86
Plastec 50	800	10800	0.30	12	140	-39	96

6.3 Dimensions

6.3.1 PLASTECS Series

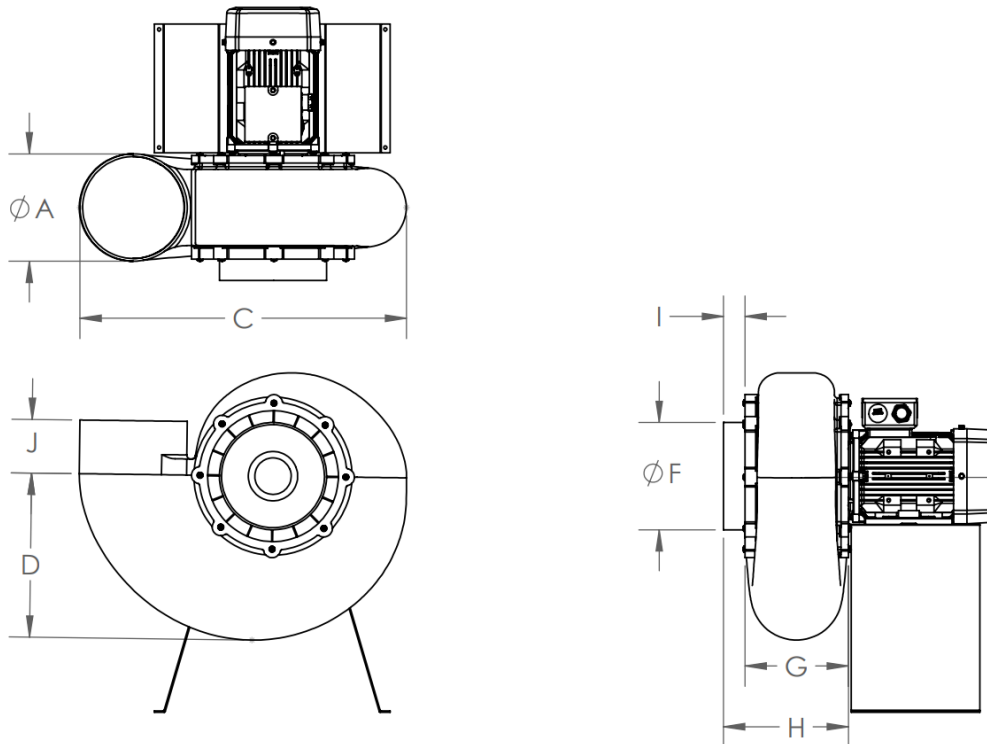



Sub Series	ØA (OD) in (mm)	C in (mm)	D in (mm)	ØF (OD) in (mm)	G in (mm)	H in (mm)	I in (mm)	J in (mm)
Plastec 15	4.91 (125)	16.11 (410)	7.98 (203)	4.91 (125)	5.7 (144)	6.84 (174)	1.18 (30)	3.93 (100)
Plastec 20	6.29 (160)	20.08 (511)	9.43 (240)	6.29 (160)	6.5 (166)	7.74 (197)	1.22 (31)	3.93 (100)
Plastec 25	7.86 (200)	23.99 (610)	12.03 (306)	7.86 (200)	7.6 (193)	9.16 (233)	1.57 (40)	3.93 (100)
Plastec 30	9.83 (250)	29.2 (743)	14.66 (373)	9.83 (250)	8.8 (223)	9.97 (253)	1.22 (31)	4.17 (106)
Plastec 35	12.38 (315)	36.94 (940)	17.69 (450)	12.38 (315)	12 (306)	14.5 (368)	2.44 (62)	4.17 (106)

6.3.2 PLASTEC 50

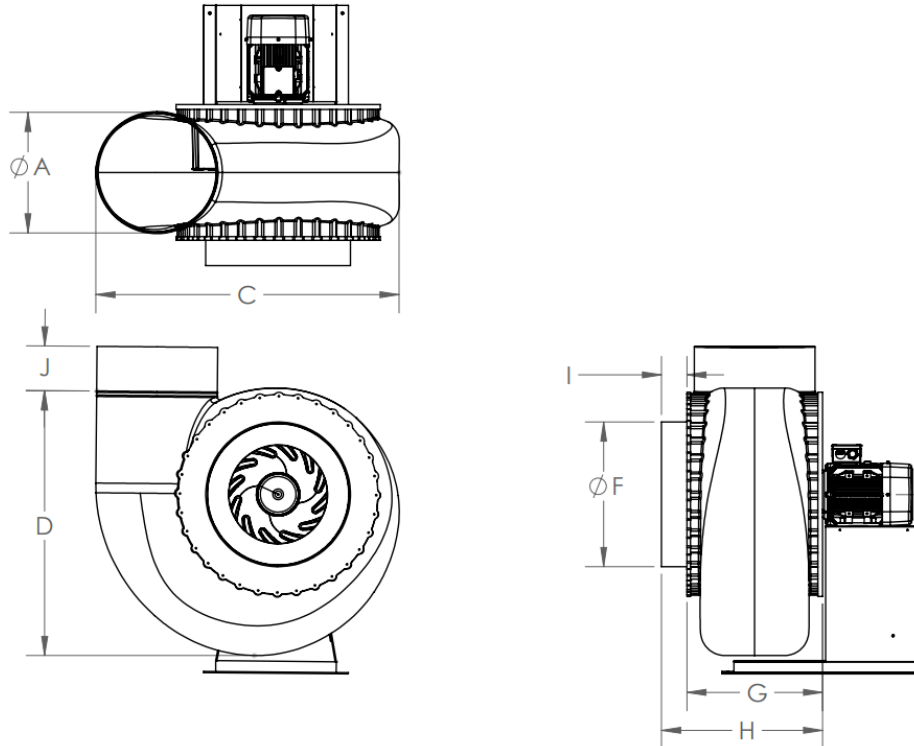



Sub Series	ØA (OD) in (mm)	C in (mm)	D in (mm)	ØF (OD) in (mm)	G in (mm)	H in (mm)	I in (mm)	J in (mm)
Plastec 50	19.95 (500)	49.5 (1259)	42.9 (1094)	23.6 (600)	22.1 (563)	26.3 (668)	4.13 (105)	7.27 (185)

6.4 Expanded View

6.4.1 PLASTEC Series

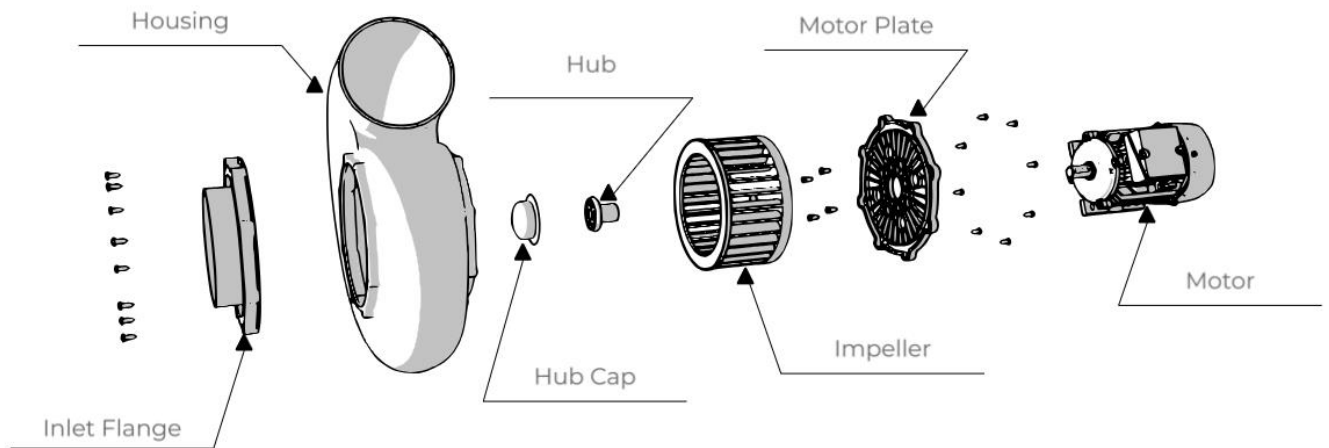

6.4.2 PLASTEC 50

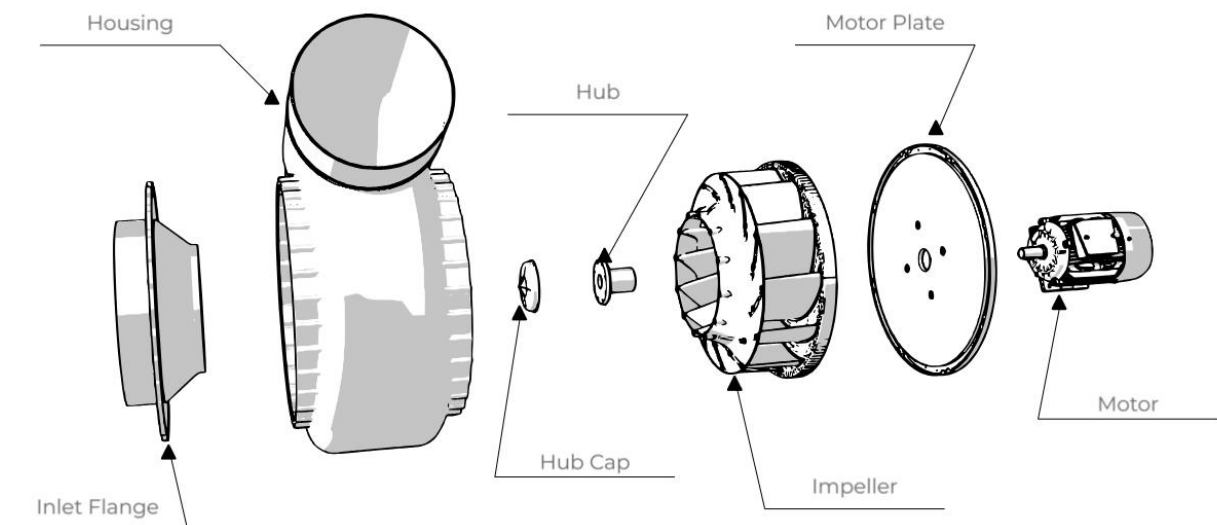



7 Installation

The area where fan(s) are installed should provide support for rigid mounting of the fan(s). Fans not supported properly will cause vibration that could cause damage or injury!

It is recommended to mount the fan(s) on a flat, level surface. This includes concrete pads, C-channels/C-Struts, roof curbs, steel platforms, metal plates, etc.

The fan(s) should be securely mounted when installed. Failure to do so can result in accidental tipping of the fan.

Use guy wires to secure roof mounted units, stacks and accessories where excessively windy conditions are prevalent.

7.1 Handling Information

When handling the fan(s), ensure that all the necessary safety precautions are taken, as outlined in *2 Safety Information*. Please ensure that the required safety procedures are followed and that personnel are wearing the proper PPE.

7.1.1 Rigging Instructions

Larger PLASTEC series blowers will require the use of cranes or lifting systems for rooftop installations. These systems will have hooks and lift points on the motor. Depending on the motor, the motor will have one central lift point or two separate lift points.

WARNING! When lifting the blower, ensure that the necessary safety precautions are taken. All personnel involved in the rigging and lifting of the blower must wear the appropriate PPE. Only trained and qualified personnel should be involved in the rigging and lifting process.

Inspect all equipment before rigging the blower, including lifting devices, hooks, straps, and slings. Inspect the lift points on the motor before continuing with the rigging of the blower.

WARNING! Only lift the blower by the lift points on the motor. Lifting the blower through any other means will damage the blower. Lifting the blower through any other means other than the lift points on the motor will lead to the failure of the rigging.

Motors with a singular lift point will have a hook on the rear of the motor. This hook is capable of lifting the entire blower assembly. Loop the cabling through the hook or attach another hook to this point to lift the blower assembly.

Motors with two lift points will have the lift points on the side of the motors. When lifting these motors, use two individual hooks to ensure the stability of the blower system. Otherwise, loop the two lift points together with cabling or straps. Ensure that the cabling or straps are behind the junction box of the motor. Looping the junction box of the motor with the lift points will result in damage to the motor.

7.2 Installation Orientations

The direction of rotation is determined from the drive or motor side of the fan. All blowers ship CCW 360 or in the up-blast position unless specified otherwise. For single inlet fans, it's important to note that the drive or motor side of the fan is always considered to be on the opposite side of the fan inlet.

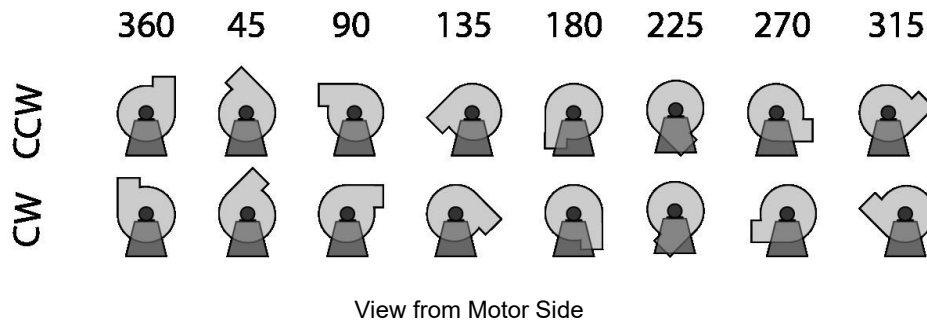

7.3 PLASTEC Series

7.3.1 Disassembly Instructions

1. Place the blower face down (Onto the inlet/with motor vertical) on a table that can support the weight of the blower.

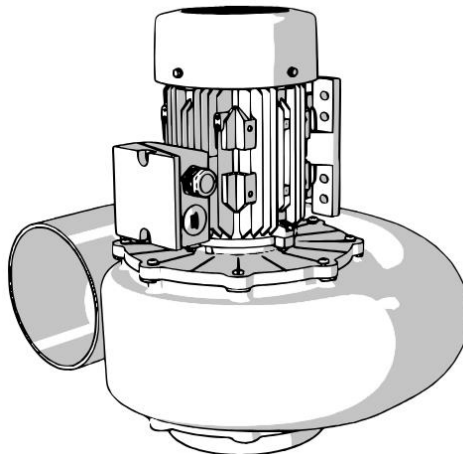

2. Remove the T25 Torx head screws from the motor plate. (There will be 8 or 16 screws depending on the blower. There may be a screw already missing in front of the motor junction box)

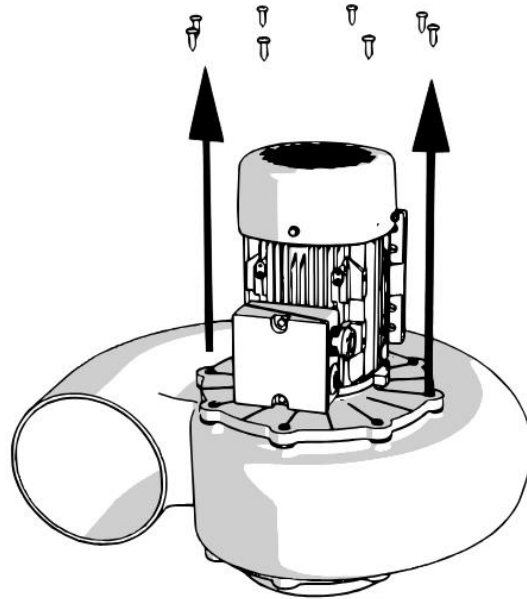

3. Pull the motor assembly from the blower housing. It may require some force to unseal the motor plate from the blower housing. Be careful not to damage the impeller.

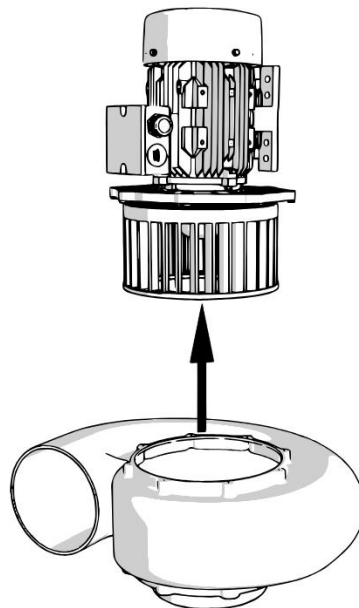

4. Using a long flathead screwdriver or a flat pry tool, remove the hub cap from the center of the impeller. It may require going through the blade of the impeller to remove the hub cap. Be careful not to damage the impeller.

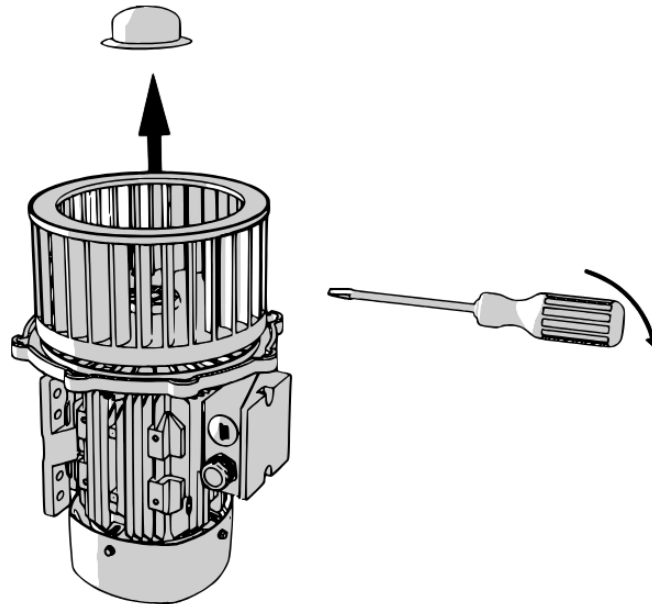

5. Remove the shaft bolt and washer in the center of the impeller from the shaft of the motor.
6. Remove the impeller from the motor shaft.
 - a. For the P20 and up, removing the impeller will require the aid of a gear/bearing puller. To do so, remove 2 of the bolts from the green bushing/hub of the impeller. Screw in the same bolts with the addition of a washer on each bolt. Hook the arms of the bearing puller onto the washers that were just added with the center screw of the puller on the shaft of the motor. Begin pulling the impeller from the motor shaft. At a certain point, it may require adding a spacer to the middle of the impeller for extra leverage. A bolt with the head facing up can act as a spacer. Continue pulling until the impeller is removed from the shaft.
 - b. For the P15, the impeller can be removed using 2 flathead screwdrivers. Place the screwdrivers between the motor plate and the impeller and pry slowly until the impeller is removed from the shaft.

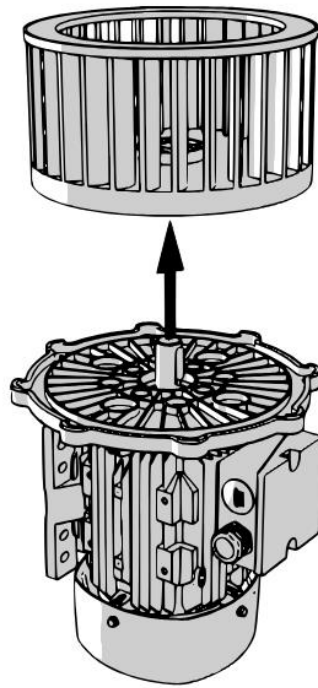

7. Remove the 4 bolts going through the motor plate into the C face of the motor.

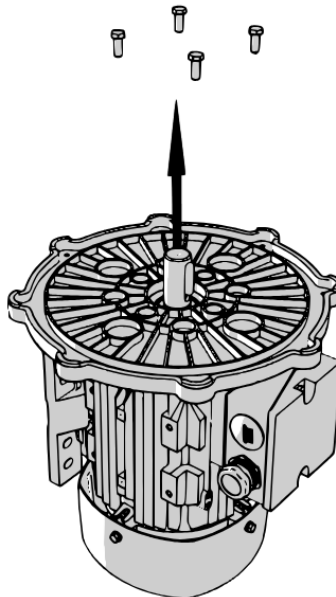

8. Remove the motor plate from the C face of the motor.

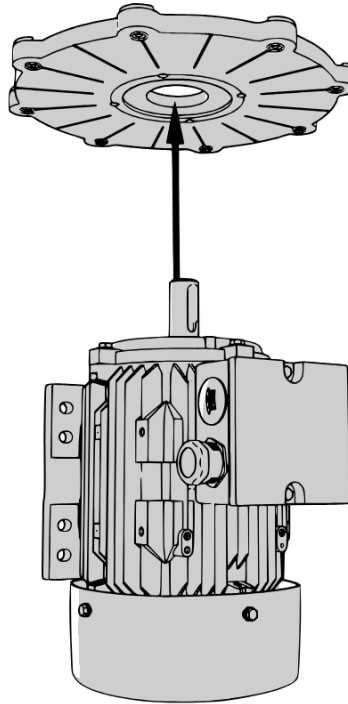

7.3.2 Assembly/Reassembly Instructions

1. Place the motor with the shaft facing upwards on a table that can support the weight of the blower.

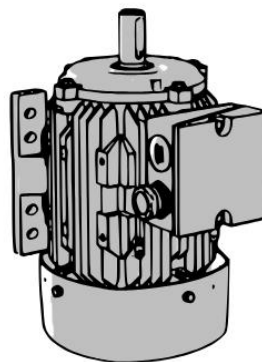

2. Set the motor plate onto the C face of the motor. It may require a small hammer or dead blow mallet to set the plate onto the rabbet. It will not require that much force to properly seat the motor plate.

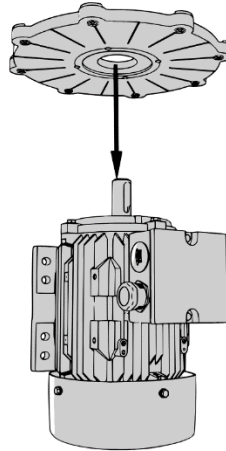

3. Secure the motor plate screwing the 4 bolts and washers through the plate into the C face of the motor.

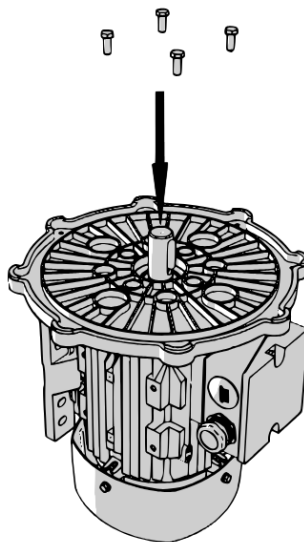

4. Align the impeller with the top of the motor shaft, ensuring that it is level. Push the impeller down the shaft until it touches the shaft shoulder. If the fit is tight or the impeller gets stuck at any point, it may require the use of a driving rod and mallet. When using a driving rod, only use it on the bushing in the center of the impeller. Place the driving rod

on the bushing and smack with the mallet until the impeller touches the shoulder. Do not hit with excessive force as it may cause damage to the bearings. Ensure that the impeller can rotate freely. Using the supplied bolt, screw down the impeller onto the shaft. If there is a gap between the tip of the shaft and the top of the bushing, then use a stainless-steel washer to fill the gap.

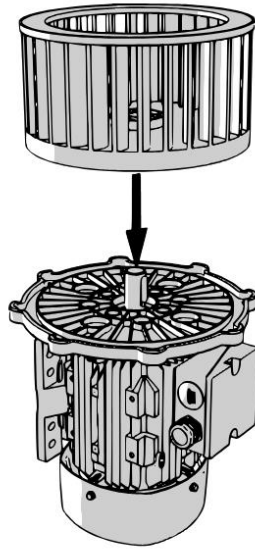

5. Cover the hub bushing with the hub cap. Use a driving rod and mallet to seat it properly.

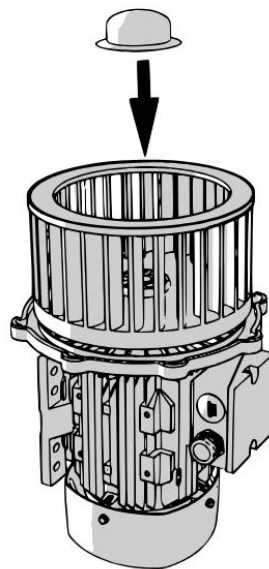

6. Place the blower housing with the inlet downward on the table.

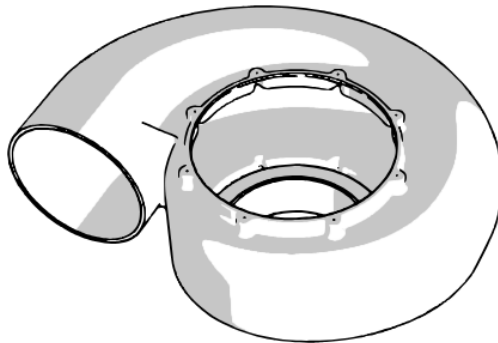

7. Select the desired orientation of the fan housing. There are up to eight possible orientations, which can be seen below. Remember that the direction of the fan (Clockwise or Counter-Clockwise) is found by looking from the rear of the motor. If the blower is being installed in a weather hood, the motor will be mounted upside down so blower orientation should be adjusted accordingly.
8. Once the desired orientation is selected, lift the motor assembly, and lower it into the blower housing, being careful not to damage the impeller.

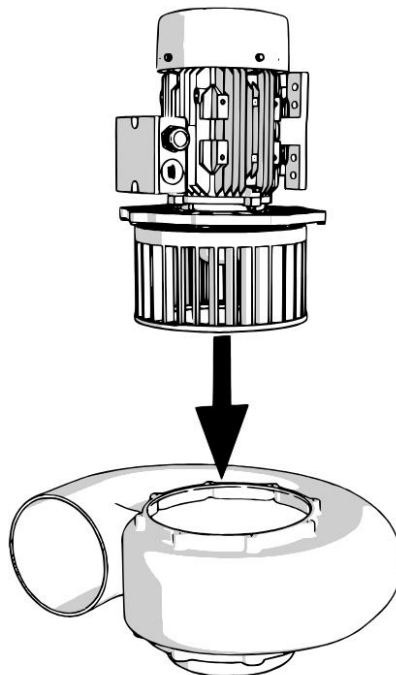

- Using the supplied Torx head screws (Either 8 or 16), secure the motor assembly to the blower assembly. Depending on the supplied motor, one screw may not be able to be screwed in due to the size and placement of the motor junction box. Do not apply max torque when screwing to avoid damage to the screw holes or housing.

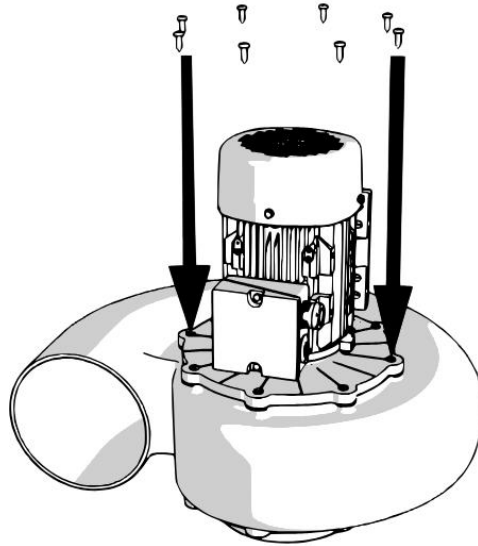

- Orient the fan so that the inlet is accessible. Ensure that the impeller can rotate freely and does not rub on the blower housing.

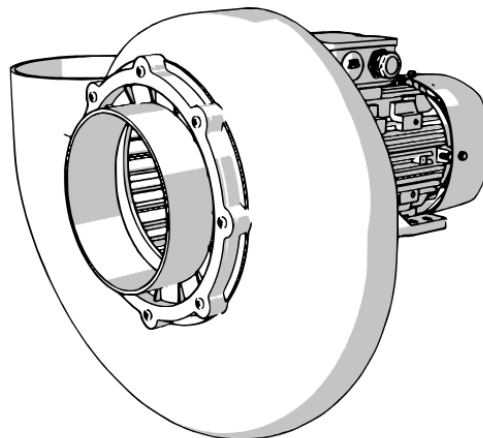

7.3.3 Counterclockwise and Clockwise Conversions

1. Place the blower face down (Onto the inlet/with motor vertical) on a table that can support the weight of the blower.

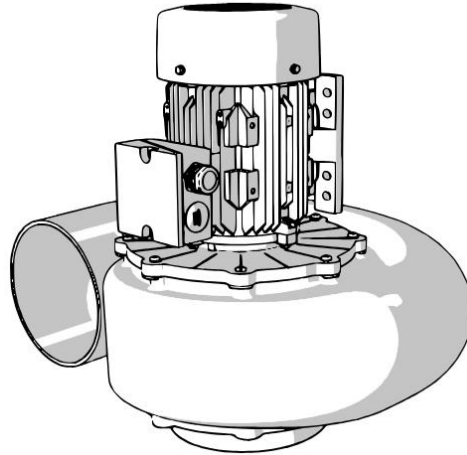

2. Remove the T25 Torx head screws from the motor plate. (There will be 8 or 16 screws depending on the blower. There may be a screw already missing in front of the motor junction box)

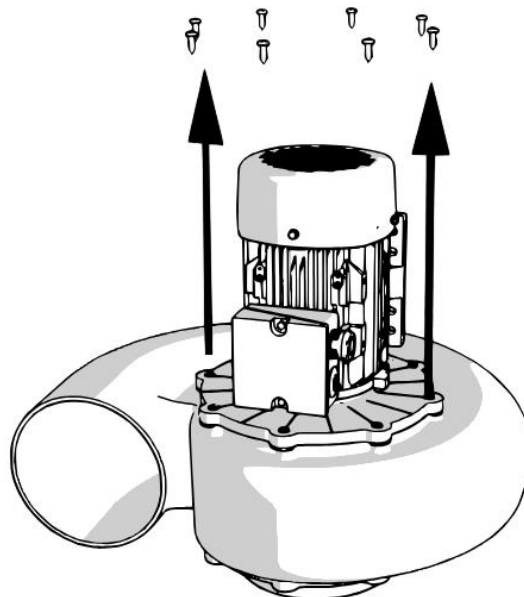

3. Pull the motor assembly from the blower housing. It may require some force to unseal the motor plate from the blower housing. Be careful not to damage the impeller.

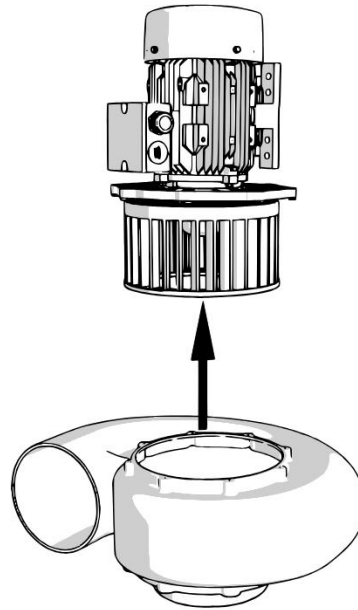

4. Using a long flathead screwdriver or a flat pry tool, remove the hub cap from the center of the impeller. It may require going through the blade of the impeller to remove the hub cap. Be careful not to damage the impeller.

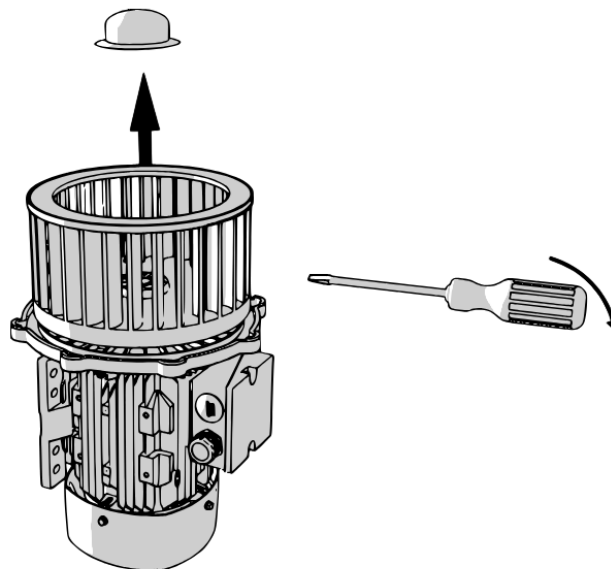

5. Remove the shaft bolt and washer in the center of the impeller from the shaft of the motor.
6. Remove the CCW impeller from the motor shaft.
 - a. For the P20 and up, removing the impeller will require the aid of a gear/bearing puller. To do so, remove 2 of the bolts from the green bushing/hub of the impeller. Screw in the same bolts with the addition of a washer on each bolt. Hook the arms of the bearing puller onto the washers that were just added with the center screw of the puller on the shaft of the motor. Begin pulling the impeller from the motor shaft. At a certain point, it may require adding a spacer to the middle of the impeller for extra leverage. A bolt with the head facing up can act as a spacer. Continue pulling until the impeller is removed from the shaft.
 - b. For the P15, the impeller can be removed using 2 flathead screwdrivers. Place the screwdrivers between the motor plate and the impeller and pry slowly until the impeller is removed from the shaft.

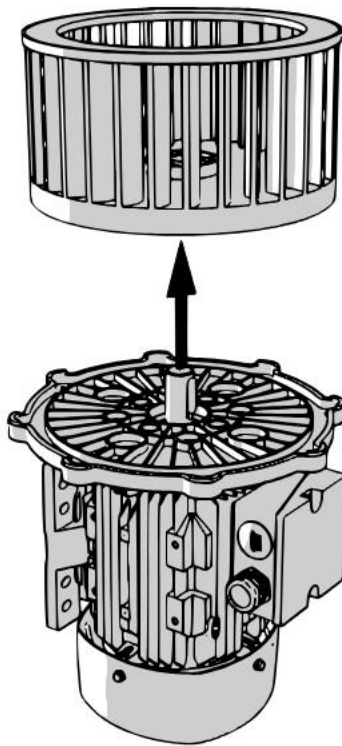

7. Align the CW impeller with the top of the motor shaft, ensuring that it is level. Push the impeller down the shaft until it touches the shaft shoulder. If the fit is tight or the impeller gets stuck at any point, it may require the use of a driving rod and mallet. When using a driving rod, only use it on the bushing in the center of the impeller. Place the driving rod on the bushing and smack with the mallet until the impeller touches the shoulder. Do not hit with excessive force as it may cause damage to the bearings. Ensure that the impeller can rotate freely. Using the supplied bolt, screw down the impeller onto the

shaft. If there is a gap between the tip of the shaft and the top of the bushing, then use a stainless-steel washer to fill the gap.

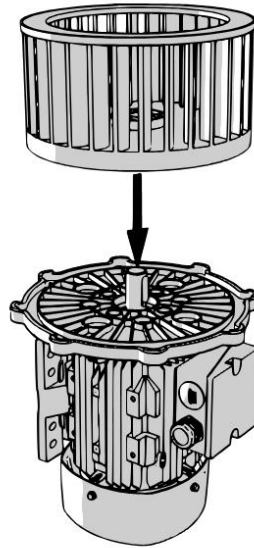

8. Cover the hub bushing with the hub cap. Use a driving rod and mallet to seat it properly.

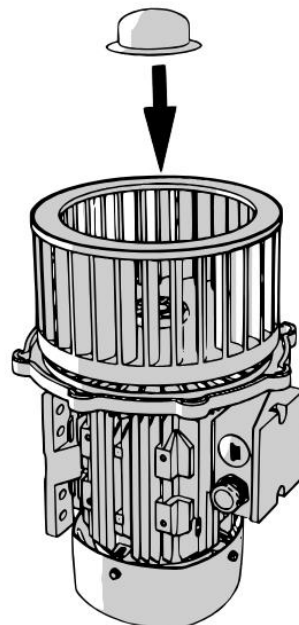

9. Remove the T25 Torx head screws from the inlet flange. (There will be 8 or 16 screws depending on the blower.)

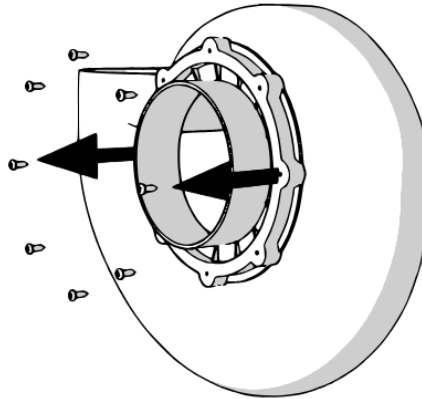

10. Remove the inlet flange from the blower housing.

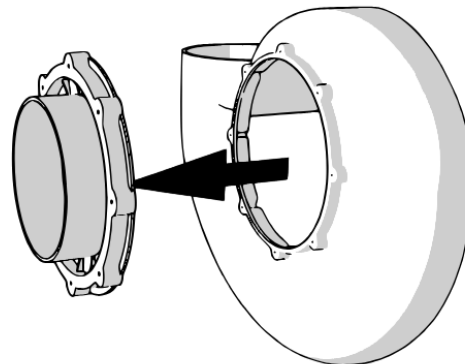

11. Reinstall the inlet flange on the opposite side of the housing. (The direction of the housing is determined by looking from the motor side of the blower)

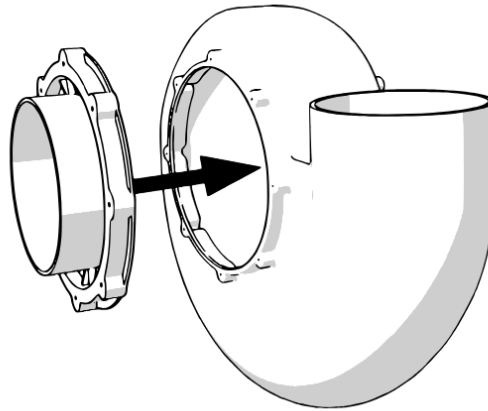

12. Using the previously removed Torx head screws to secure the inlet flange. Do not apply max torque when screwing to avoid damage to the screw holes or housing.
13. Place the blower housing with the inlet downward on the table.

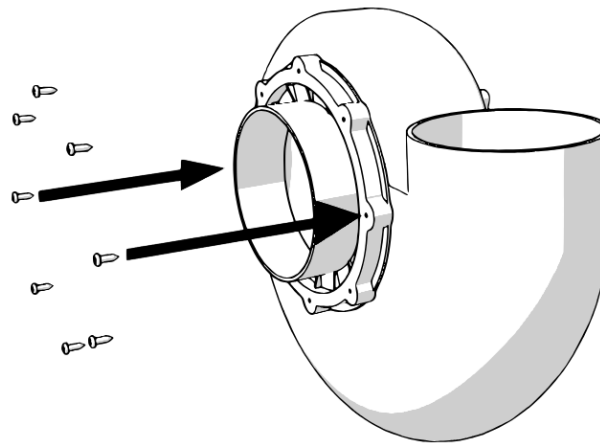

14. Select the desired orientation of the fan housing. There are up to eight possible orientations, which can be seen below. Remember that the direction of the fan (Clockwise or Counter-Clockwise) is found by looking from the rear of the motor. If the blower is being installed in a weather hood, the motor will be mounted upside down so blower orientation should be adjusted accordingly.
15. Once the desired orientation is selected, lift the motor assembly, and lower it into the blower housing, being careful not to damage the impeller.

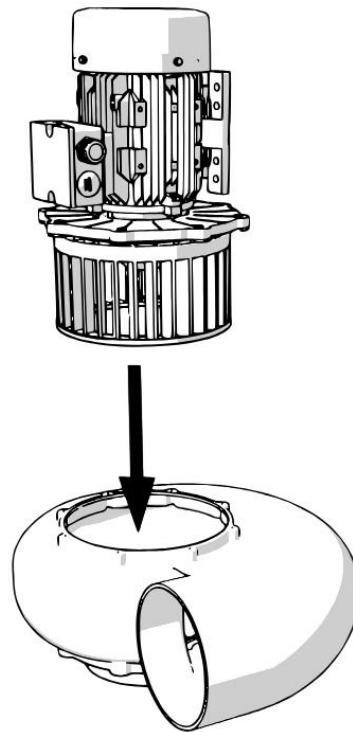

16. Using the supplied Torx head screws (Either 8 or 16), secure the motor assembly to the blower assembly. Depending on the supplied motor, one screw may not be able to be screwed in due to the size and placement of the motor junction box. Do not apply max torque when screwing to avoid damage to the screw holes or housing.

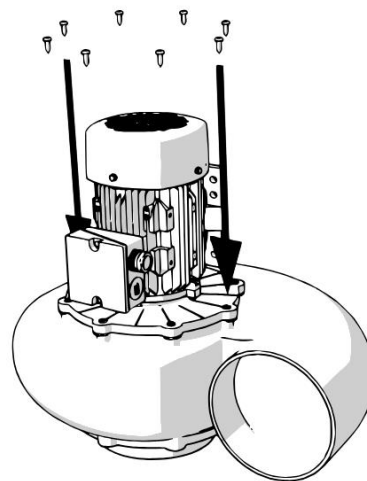

17. Orient the fan so that the inlet is accessible. Ensure that the impeller can rotate freely and does not rub on the blower housing.

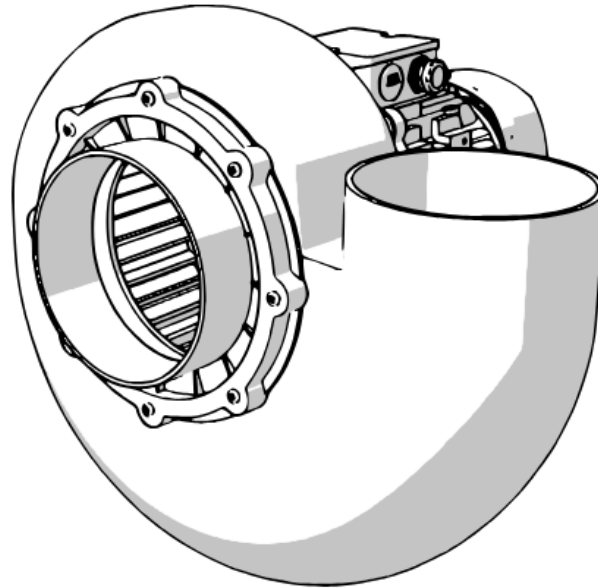

8 Electrical Installation/Wiring

WARNING! This equipment should be installed, adjusted, and serviced by qualified electrical maintenance personnel familiar with the construction and operation of the equipment and the hazards involved. Failure to observe this precaution could result in property damage and/or serious bodily injury, including death. **HIGH VOLTAGE!** Hazard of electrical shock. Disconnect incoming power before working on this control.

WARNING! Wait at least five (5) minutes after turning off the input power supply before performing maintenance or an inspection. Otherwise, there is the danger of electric shock.

CAUTION! Proper grounds, disconnecting devices and other safety devices and their location are the responsibility of the user and are not provided by Plastec Ventilation Inc.

WARNING! For equipment protection, install a ground leakage type breaker with a fast response circuit capable of handling large currents. The ground fault protection circuit is not designed to protect against personal injury.

8.1 Motors

Periodic checks of voltage, frequency and current of a motor while in operation are recommended. Such checks assure the correctness of frequency and voltage applied to the motor and yield an indication of the fan load. Comparison of this data with previous data will give an indication of the fan performance. Any serious deviations could indicate a potential motor failure.

All motors carry a one-year warranty from date of shipment. For repairs within warranty period, the motor must be taken to the motor manufacturer's authorized service dealer. Contact your representative for additional warranty details.

A periodic motor check should consist of spinning the motor shaft with the power off so to be sure the motor turns freely and the bearings run smoothly.

Repair or replacement of motors is normally performed by a repair station authorized by the manufacturer. Contact your representative or the factory for locations nearest you. **DO NOT** ship motor to factory without specific authorization forms.

8.2 Single Phase Motors

8.2.1 Techtop

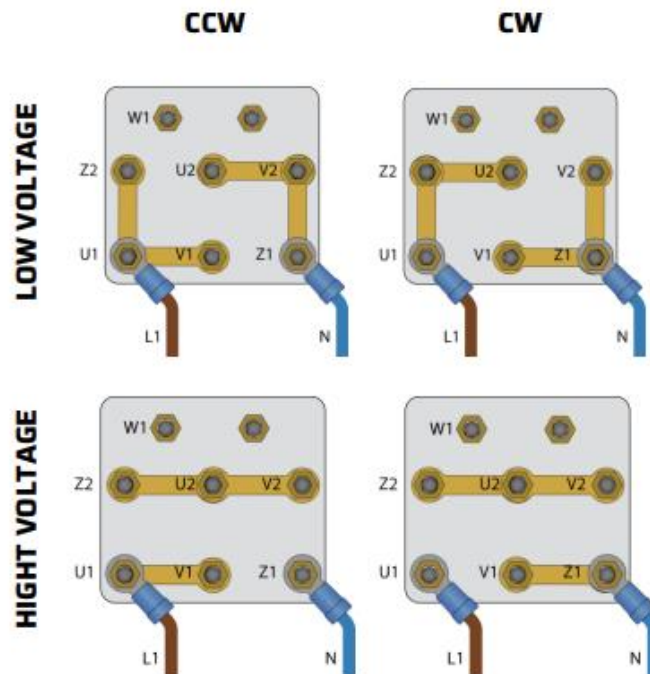

8.2.2 Elprom/Orange1

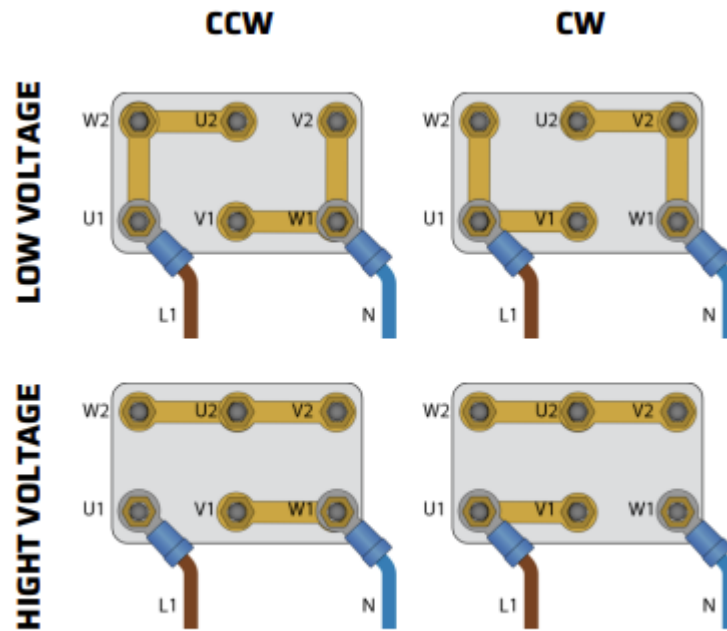

8.3 Three Phase Motors

8.3.1 Techtop

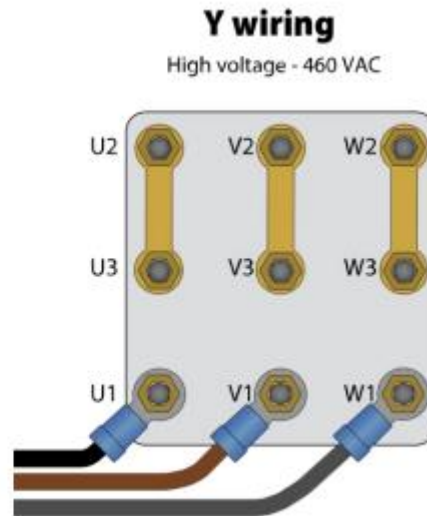
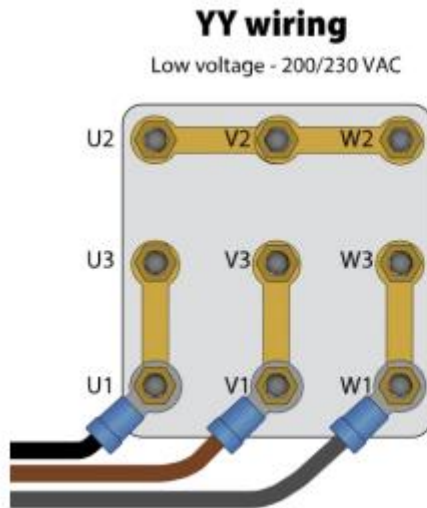

8.3.2 Elprom/Orange1

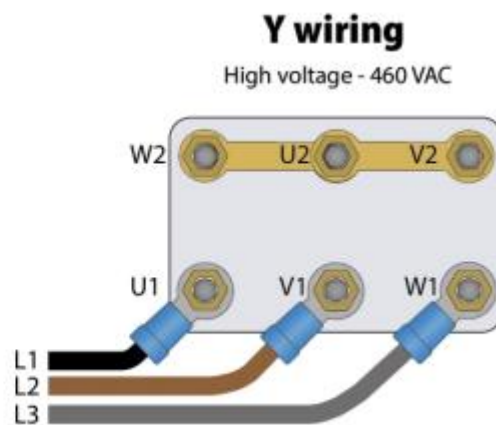
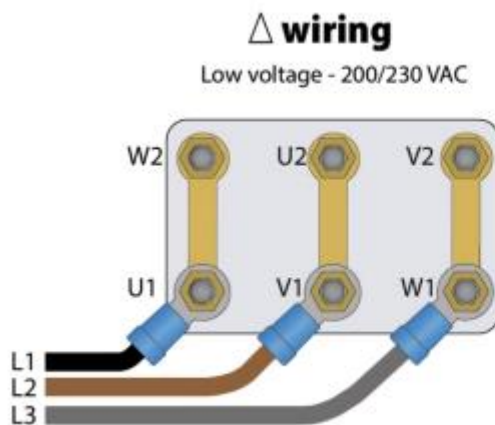

9 Accessories

9.1 Motor Support Stand

9.1.1 Installation

1. Secure the Motor support stand in the desired location before installing the blower on top of the stand. All motor support stands have a hole drilled in each of the four corners of the feet for easy mounting at the desired installation location.

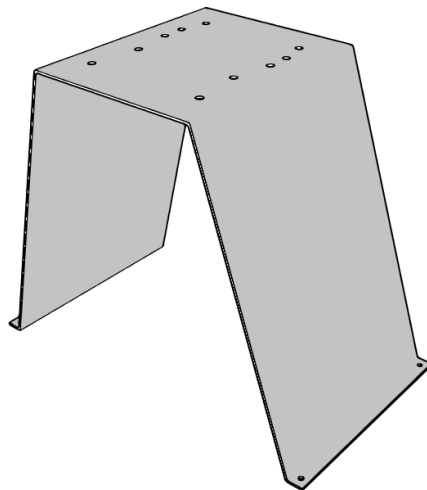

2. Gently place the blower assembly on top of the motor support stand. Align the holes in the feet of the motor with the holes drilled into the top of the motor support stand.

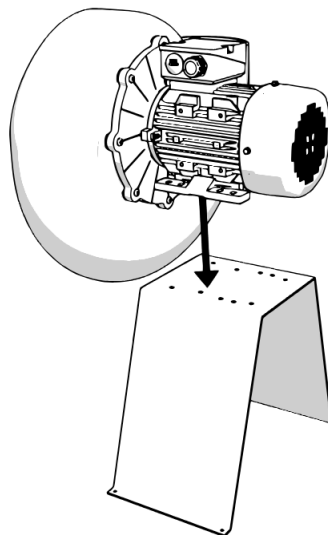

3. Insert the 4 supplied bolts through the feet of the motor and the top of the motor support stand.

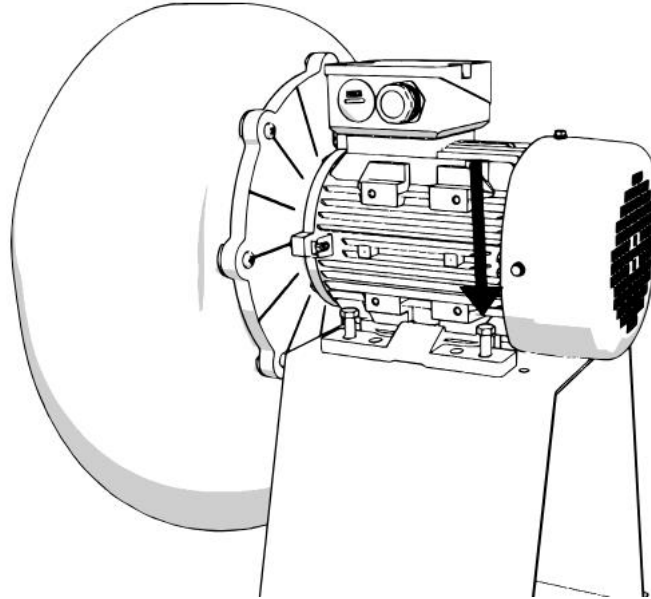

4. On the underside of the motor support stand, thread the 4 supplied nuts with the 4 supplied flat washers onto the bolts. Tighten the bolts and nuts to fully secure the blower to the motor support stand.

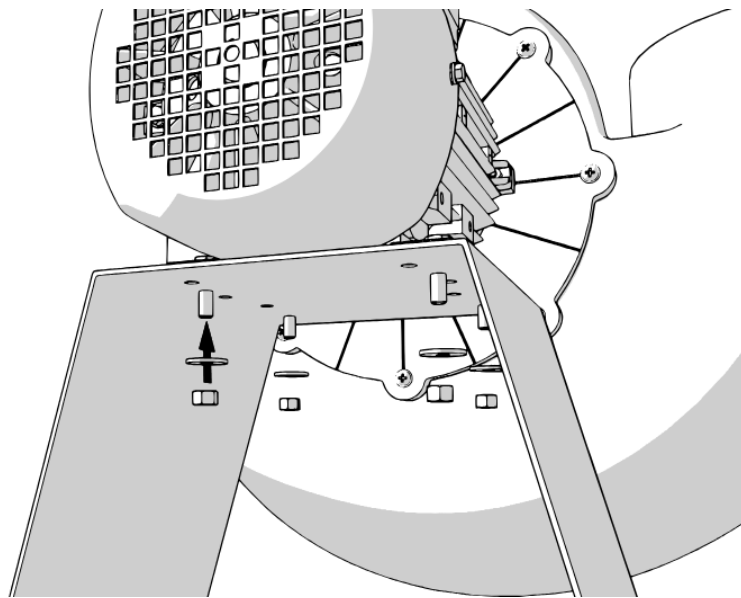

5. Ensure that the motor is completely secured to the support stand before running the blower.

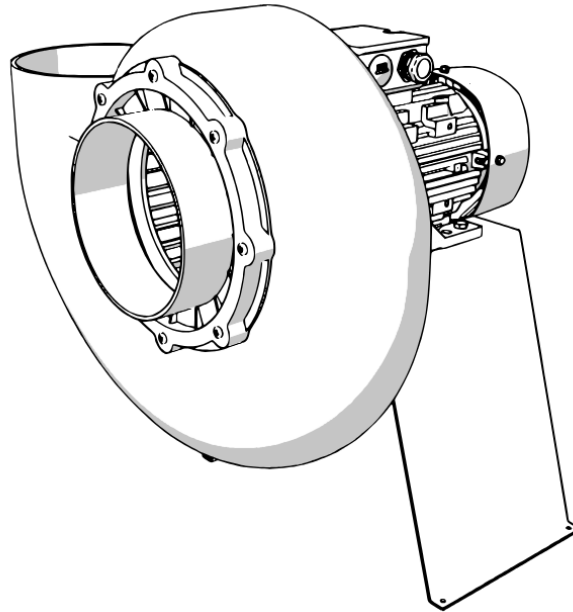

9.2 Weather hood

9.2.1 Installation

1. It is recommended to have two people when installing a blower onto a weather hood. It is recommended to begin wiring the blower motor before installing the blower on the weather hood. Wiring may become difficult after installation. Place the weather hood on its feet. Ensure that it is secured at the desired location.

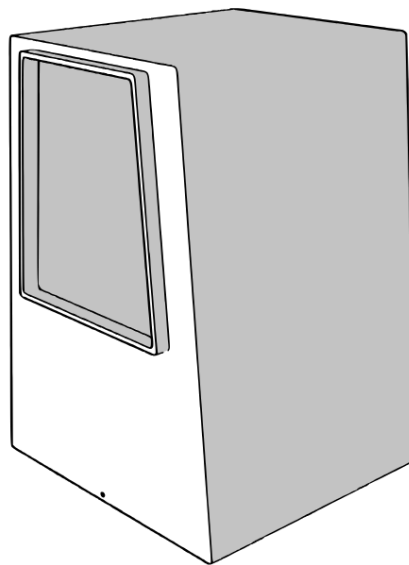

Note: Motor holes are pre-drilled according to the selected blower.

2. Insert the blower into the weather hood. The feet of the motor should be facing towards the top of the weather hood when inserting the blower.

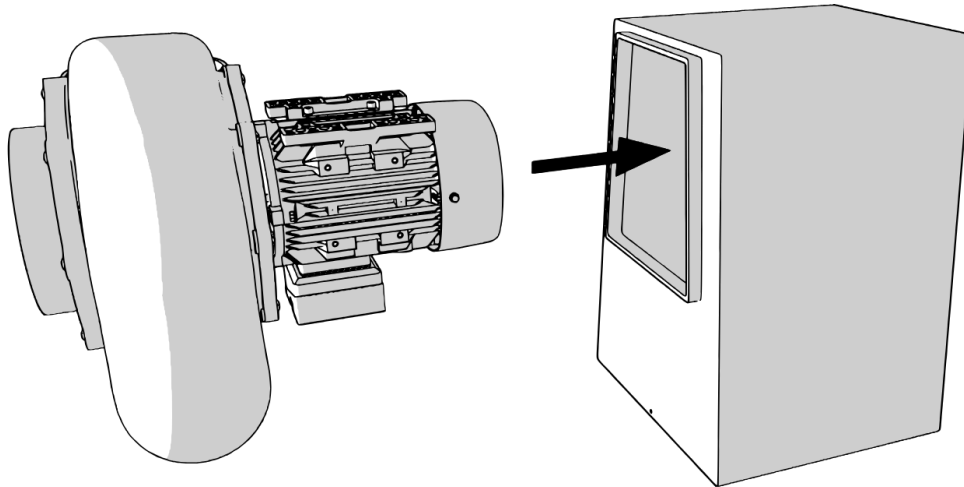

3. Hold the blower against the roof of the weather hood and align the holes in the feet of the motor with the holes drilled into the top of the weather hood.

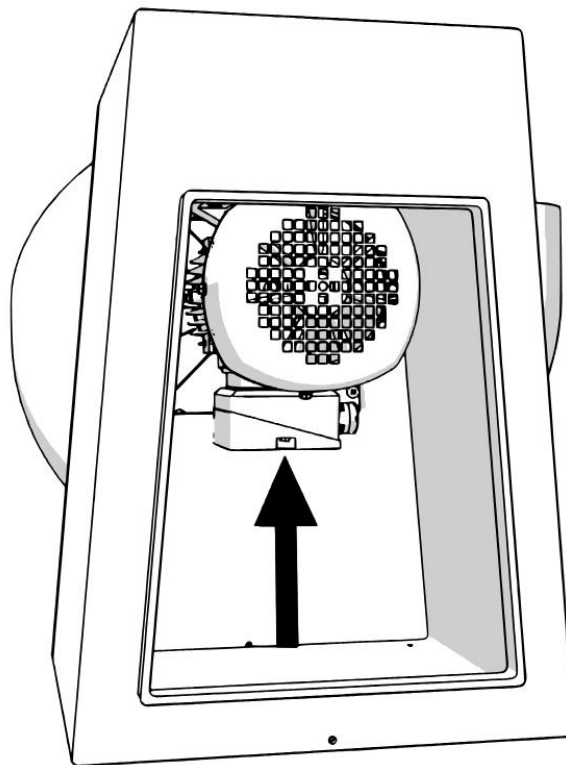

4. Insert the provided bolts through the feet of the motor and through the top of the weather hood.

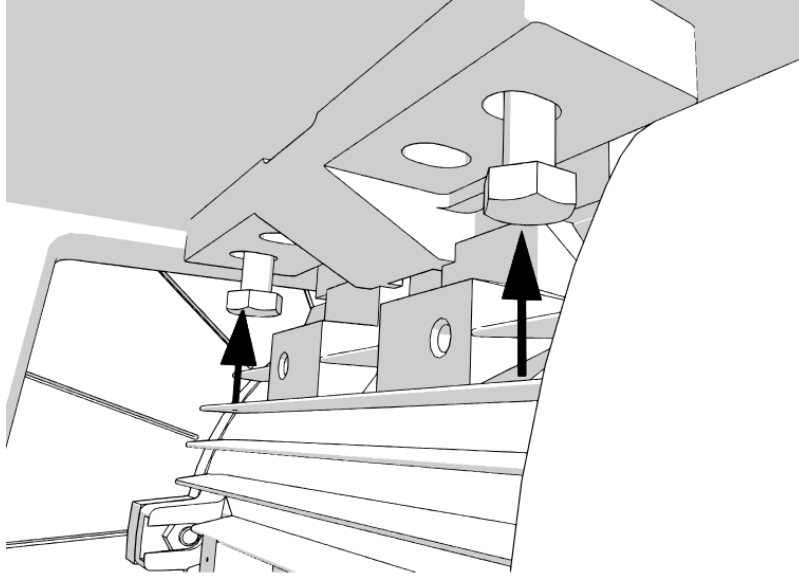

5. Place the provided washers over the bolts that are protruding through the top of the weather hood. Secure the bolts and washers with the provided nuts.

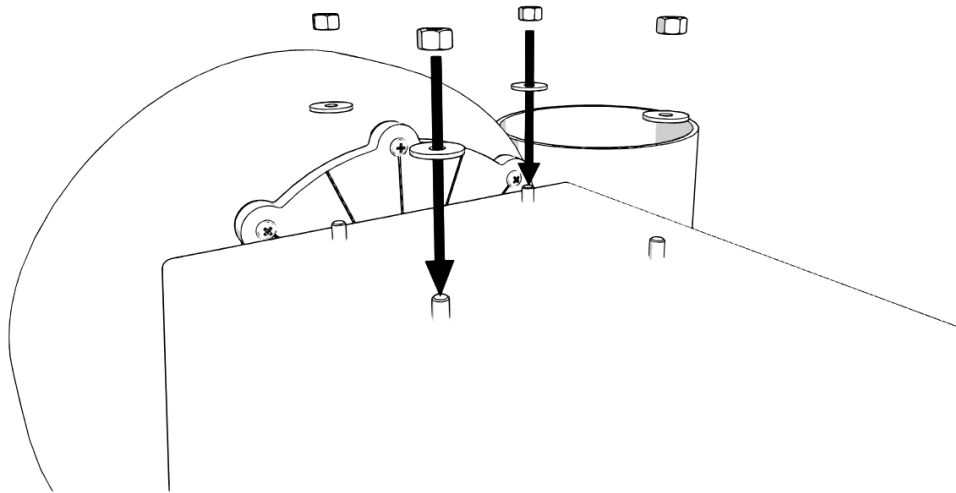

6. Ensure that the blower is completely secured to the weather hood before running the blower.

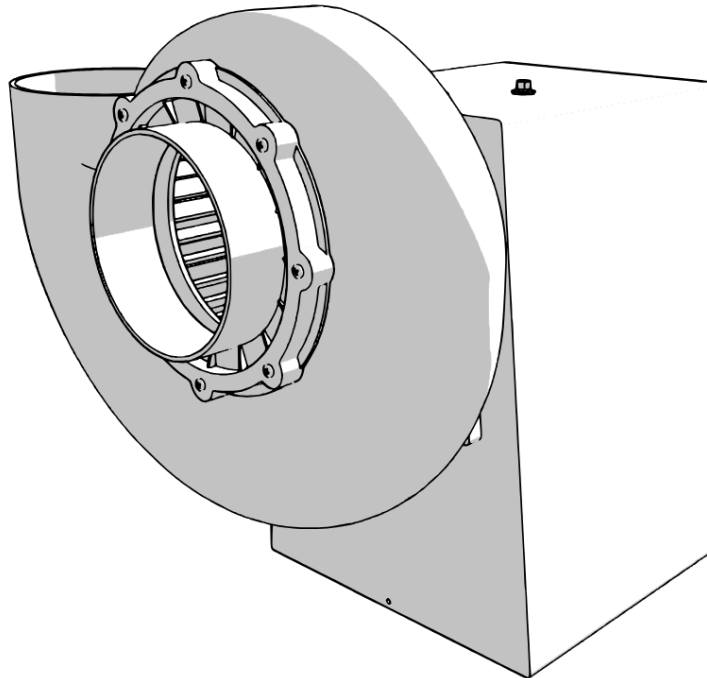

9.3 Vibration Isolators

9.3.1 Motor Support Stand Installation

1. Secure the Motor support stand in the desired location before installing the blower on top of the stand. All motor support stands have a hole drilled in each of the four corners of the feet for easy mounting at the desired installation location.

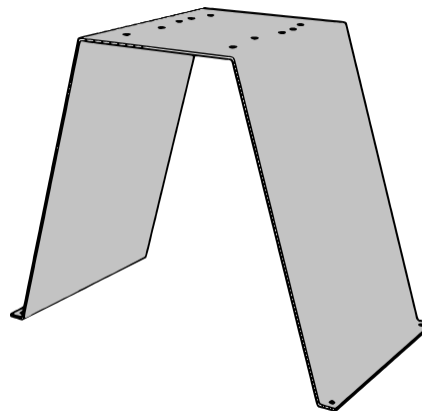

2. Place the vibration isolators into the pre-drilled holes in the motor support stand.

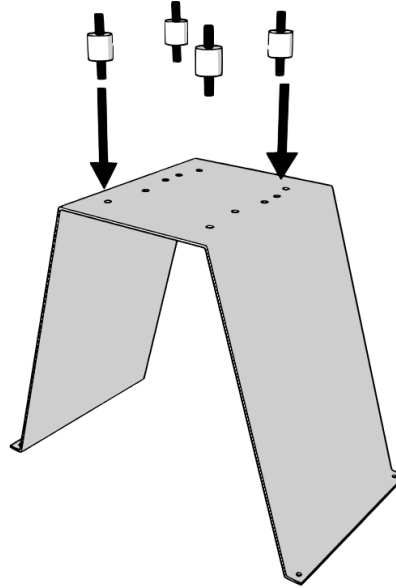

3. Secure the vibration isolators to the motor stand with the provided nuts. Ensure that the vibration isolators position aligns with the position of the holes in the feet of the blower motor.

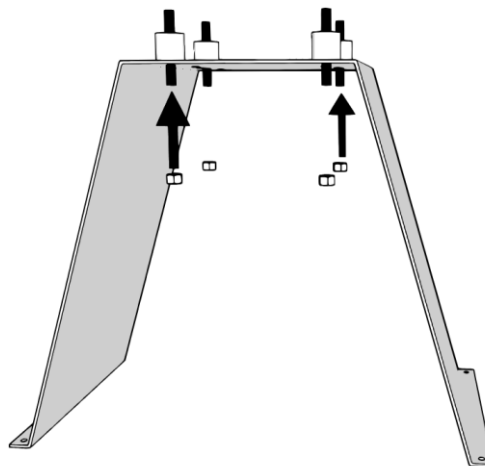

4. Place the blower assembly onto the vibration isolators.

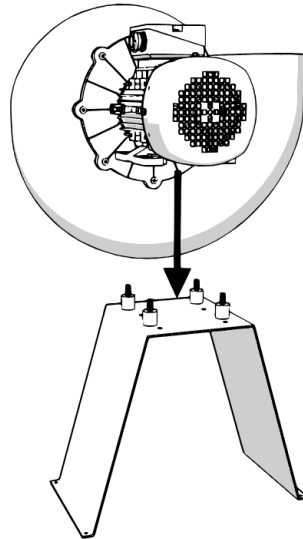

5. Secure the blower assembly to the vibration isolators with the provided nuts.

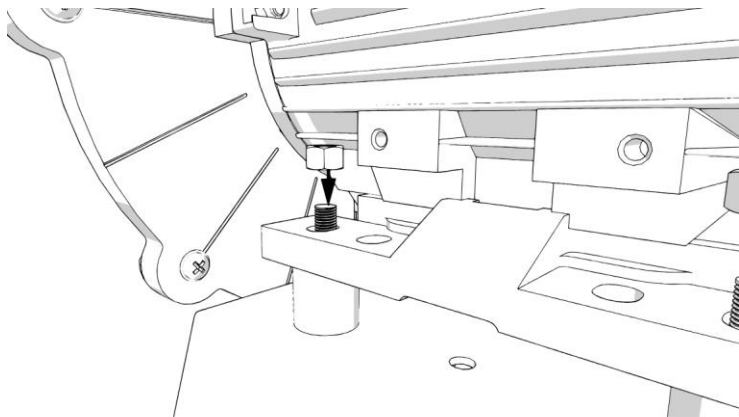

6. Ensure that the blower assembly is properly secured to the motor stand and vibration isolators before running.

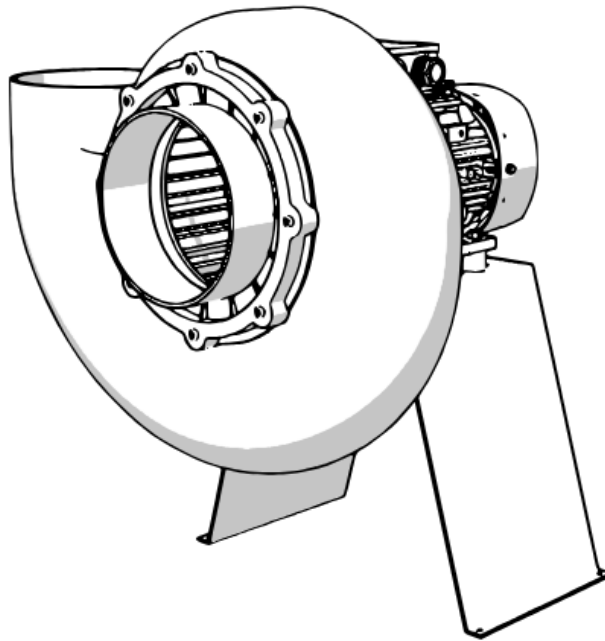

9.3.2 Weather hood Installation

1. Place the weather hood on a table or working surface. It is recommended to install the isolators before installing the blower on the weather hood.

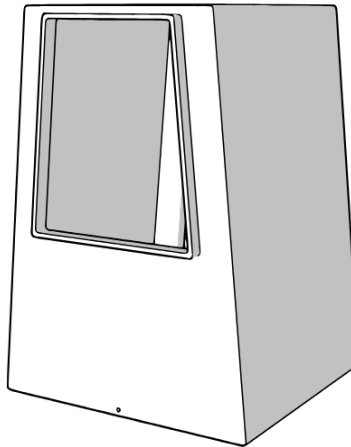

2. Lay the weather hood assembly onto the blower so that the compartment is accessible through the rear.

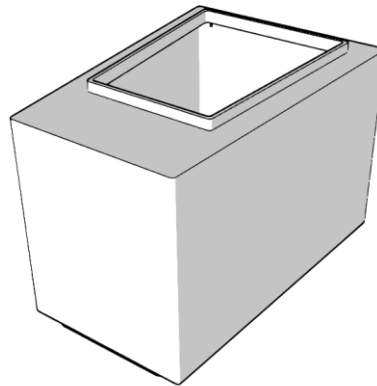

3. Insert the vibration isolators through the pre-drilled holes (The WH4 may require drilling the holes to fit the vibration isolators. It is recommended to drill the holes in the 4 corners of the weather hood).

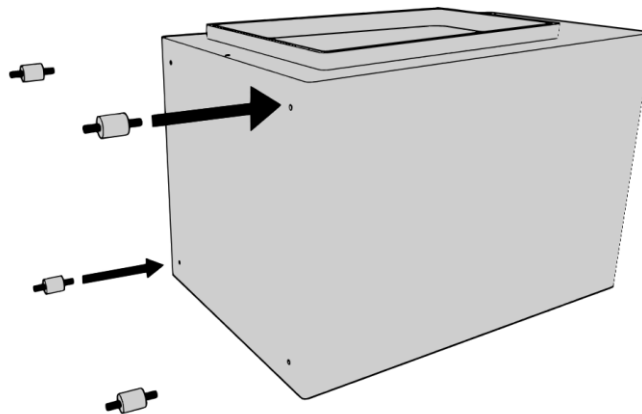

4. Through the opening in the rear, secure the vibration isolators to the weather hood with the provided nuts.

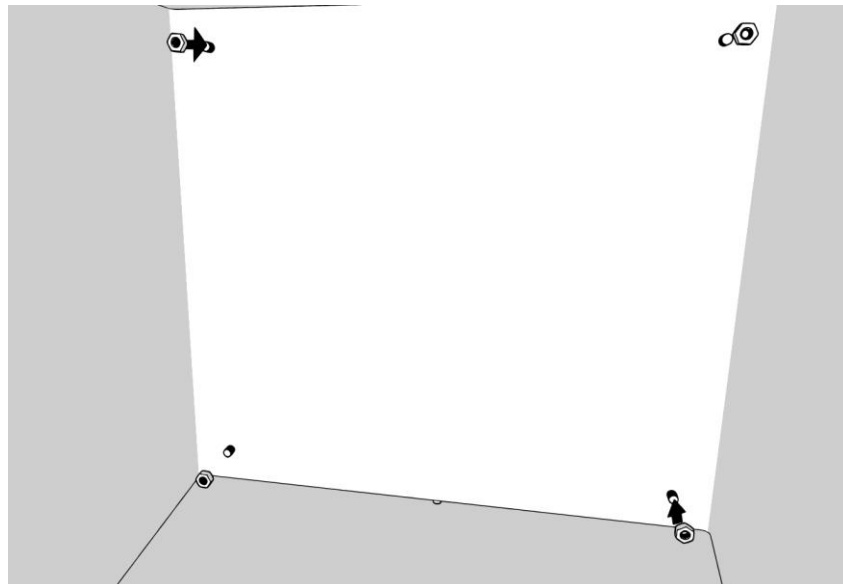

5. Ensure that the vibration isolators are properly secured to the weather hood before installing the blower.

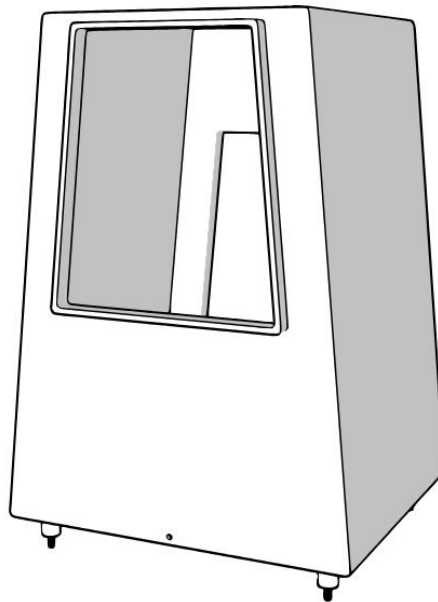

9.4 Roof Unit Kit

9.4.1 Installation

1. Place the base of the Roof Unit kit on a table or level working surface.

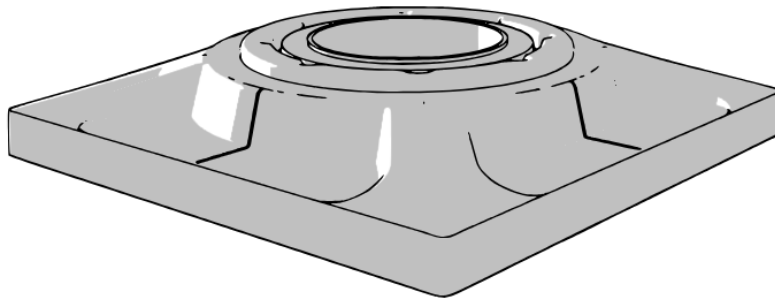

2. Select the desired orientation and direction for the blower (This is determined by looking at the blower from the motor side. In the case of the roof unit kit, this would be determined by looking down towards the base of the roof unit kit). Insert the blower housing into the base of the roof unit kit.

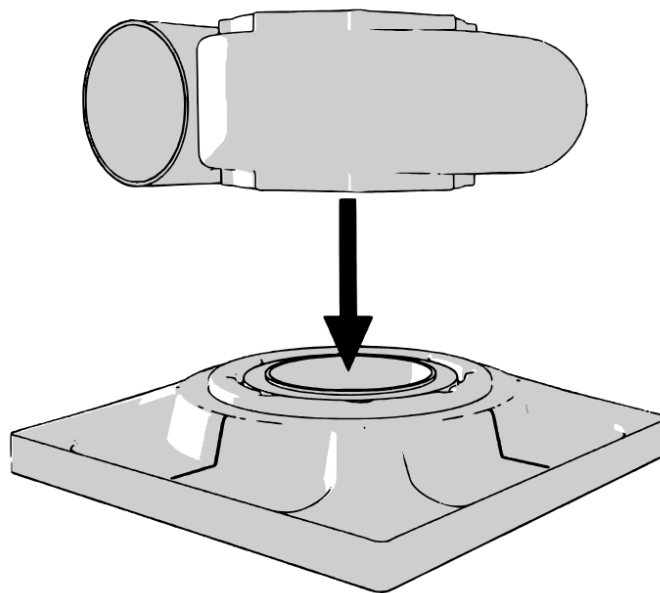

3. Rotate the roof unit kit base and blower housing to the inlet side (Bottom of the roof unit kit base) and insert the provided T25 Torx bit screws to secure the blower housing to the roof unit kit base.

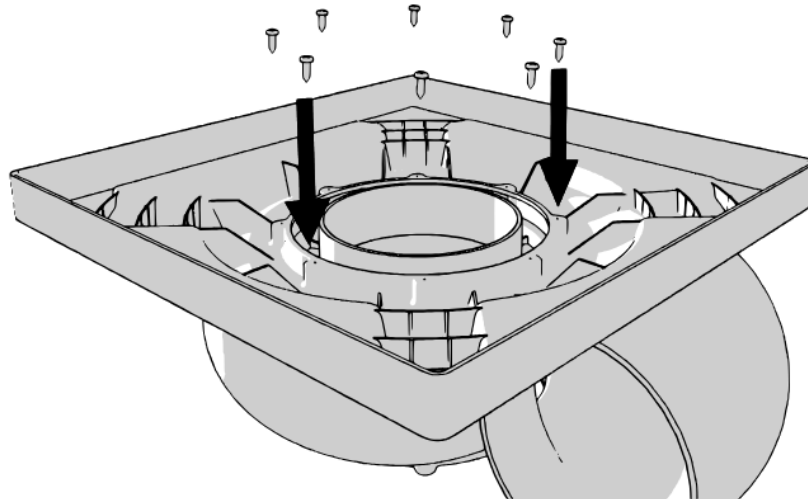

4. Place the motor with the shaft facing upwards on the work surface. Place the roof unit kit bracket on the C face of the motor with the threaded inserts facing upwards.

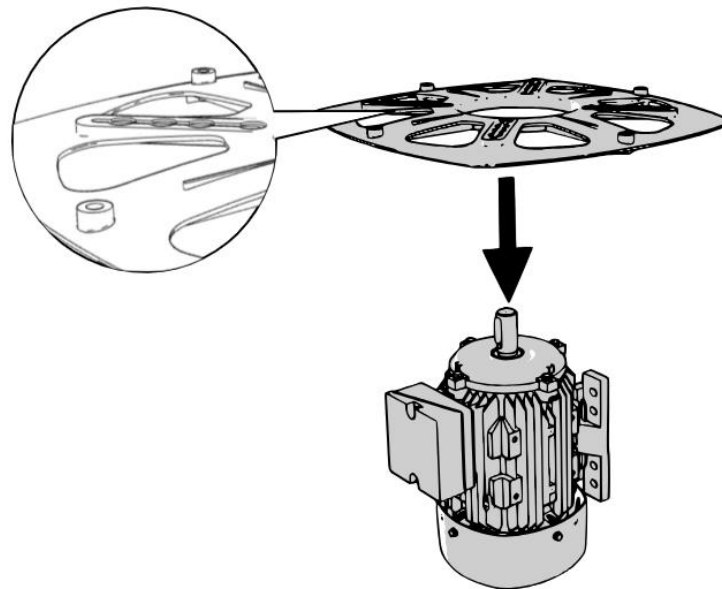

5. Set the motor plate onto the C face of the motor. It may require a small hammer or dead blow mallet to set the plate onto the rabbet. It will not require that much force to properly seat the motor plate.

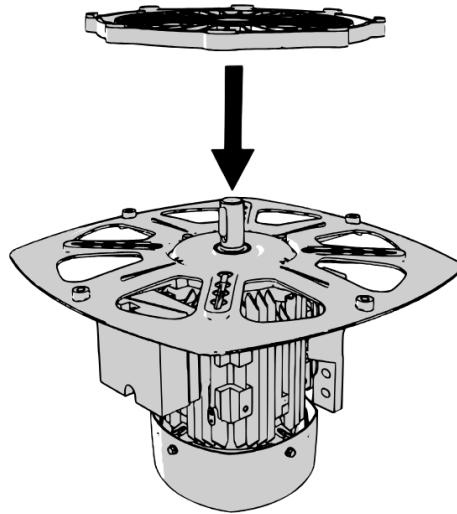

6. Secure the motor plate screwing the 4 bolts and washers through the plate into the C face of the motor.

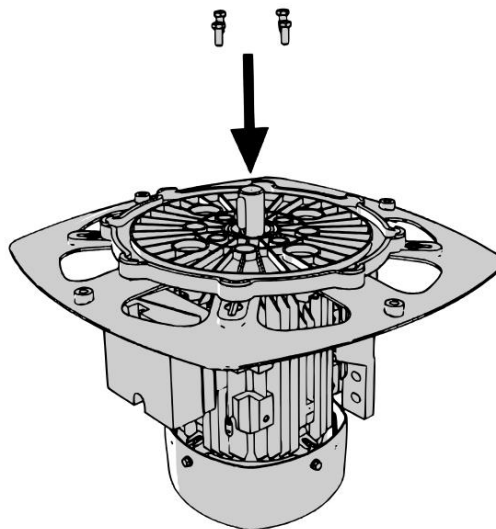

7. Align the CW impeller with the top of the motor shaft, ensuring that it is level. Push the impeller down the shaft until it touches the shaft shoulder. If the fit is tight or the impeller gets stuck at any point, it may require the use of a driving rod and mallet. When using a driving rod, only use it on the bushing in the center of the impeller. Place the driving rod on the bushing and smack with the mallet until the impeller touches the shoulder. Do not hit with excessive force as it may cause damage to the bearings. Ensure that the impeller can rotate freely. Using the supplied bolt, screw down the impeller onto the shaft. If there is a gap between the tip of the shaft and the top of the bushing, then use a stainless-steel washer to fill the gap.

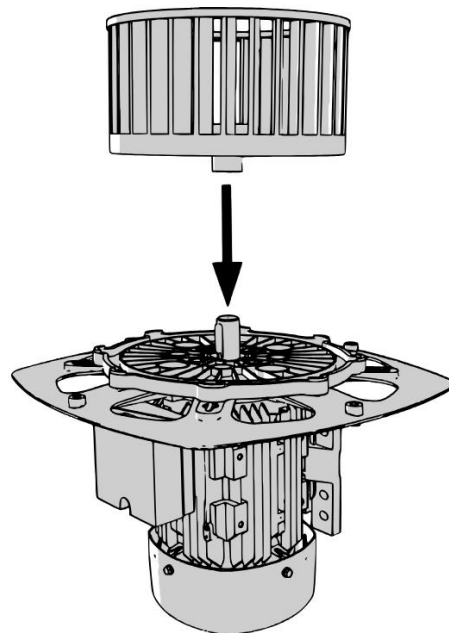

8. Cover the hub bushing with the hub cap. Use a driving rod and mallet to seat it properly.

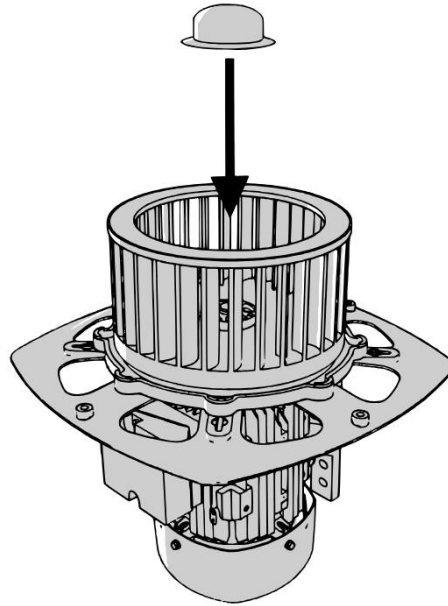

9. Lift the motor assembly, and lower it into the blower housing, being careful not to damage the impeller.

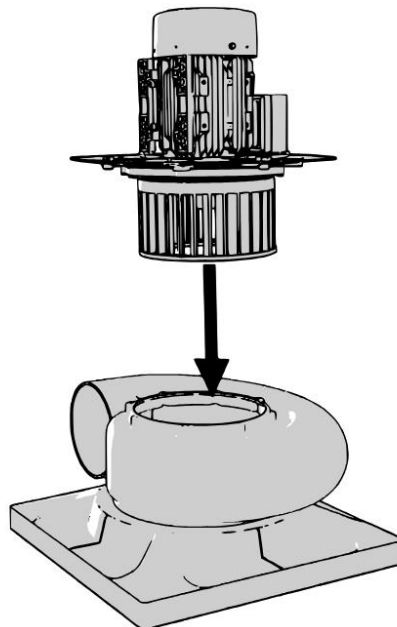

10. Secure the motor plate to the housing with the provided T25 Torx screws. Screw in 4 of the provided screws through the motor plate directly and into the blower housing. Ensure that there is a one-hole gap between all 4 screws

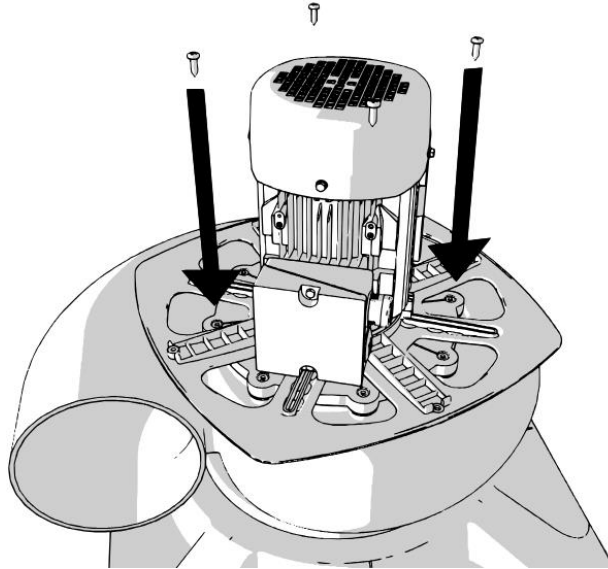

11. Rotate the roof unit kit bracket so that the slots on the bracket align with the remaining 4 empty holes in the motor plate.

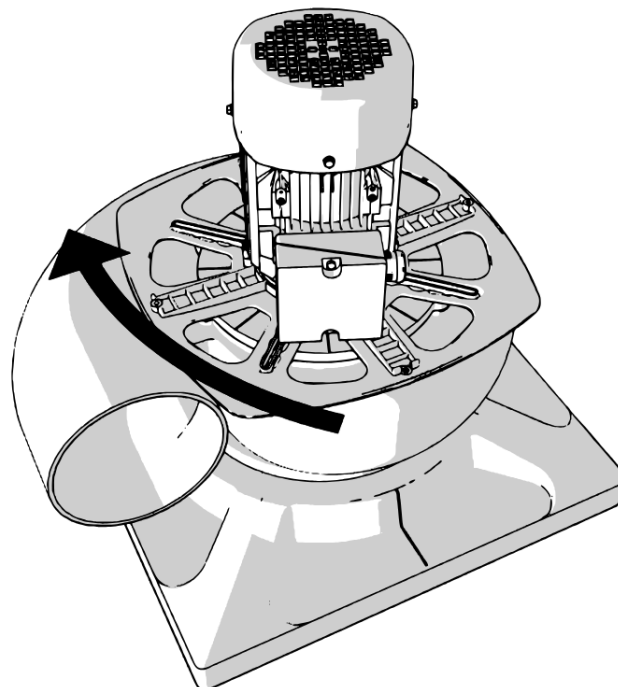

- Using the remaining provided T25 Torx screws, secure the roof unit kit bracket to the motor plate. Screw in the screws through the previously aligned slots and into the motor plate.

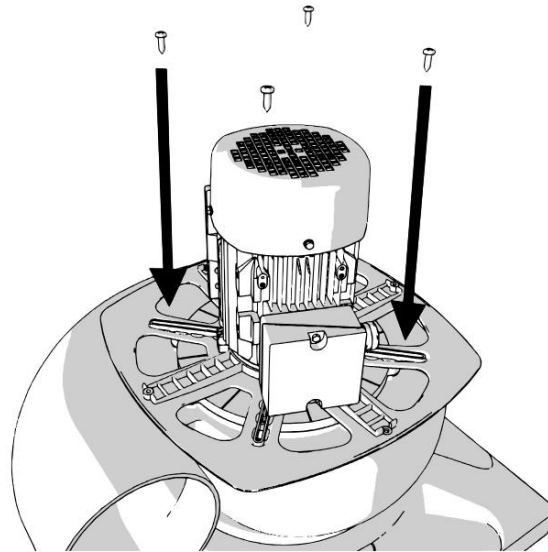

- Place the roof unit kit cap on top of the motor, making sure to align the 4 holes on the bottom of the cap with the threaded inserts on the roof unit kit bracket. It is recommended to complete any wiring before placing the cap over the motor.

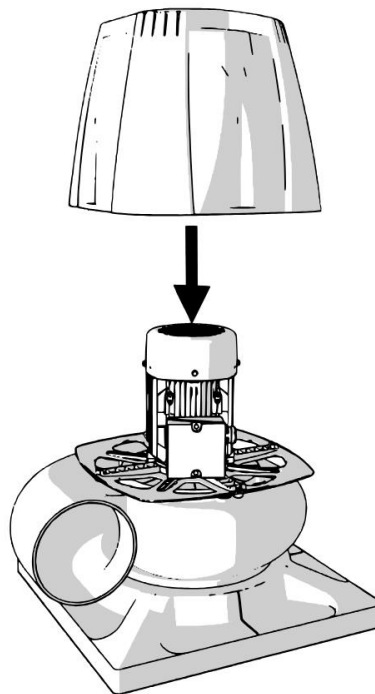

-
- Using the 4 provided Philips head screws, secure the roof unit kit cap to the roof unit kit bracket. Ensure that all parts are properly secured before starting the blower.

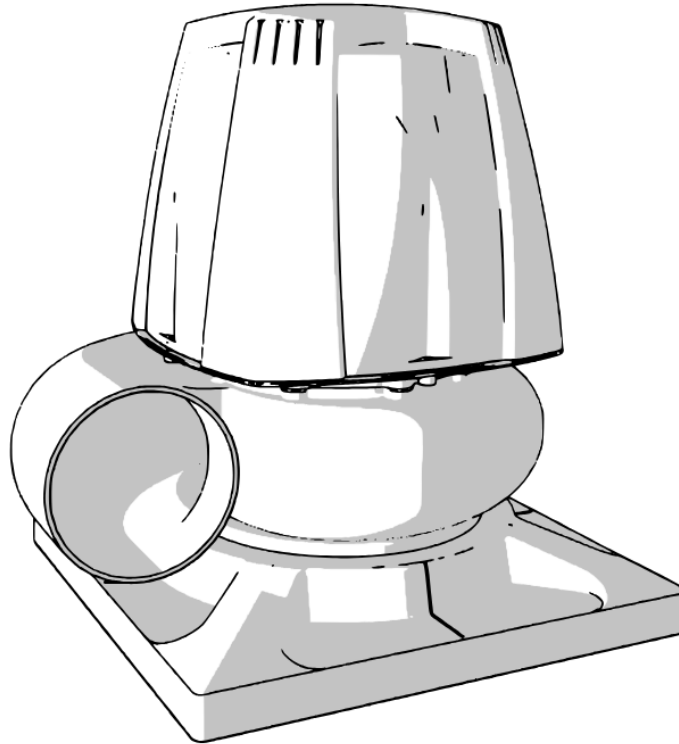

9.4.2 Roof Curb Installation

- Secure the roof curb in the desired location before installing the blower on top of the curb.

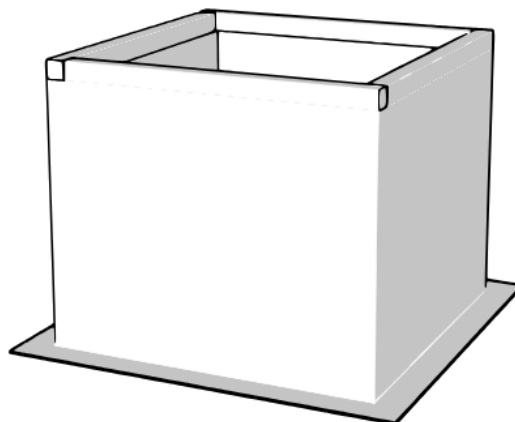

2. For ease of installation, it is recommended to use flexible tubing to connect the piping in the roof to the inlet of the Roof Kit Unit. Attach the flexible tubing from Roof top outlet pipe to inlet of the Roof Kit Unit.
3. Place Roof Kit Unit on Roof Curb. Ensure that the roof curb is seated properly within the roof cap base of the Roof Kit Unit.

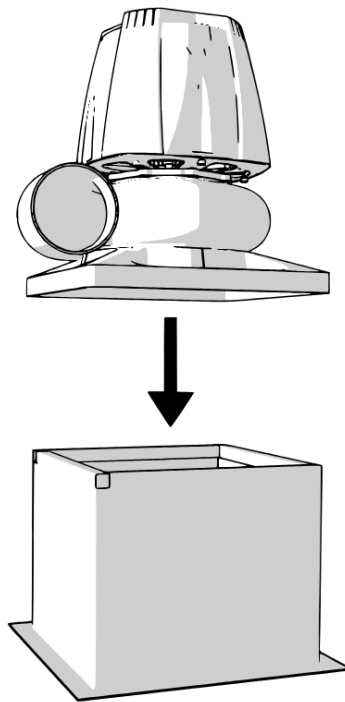

4. On the sides of the base, drill two holes near the corners of the base, going through the Roof Kit Unit and into the wooden section of the Roof Curb.
5. Secure the Roof Kit Unit using stainless steel screws through the previously drilled holes.

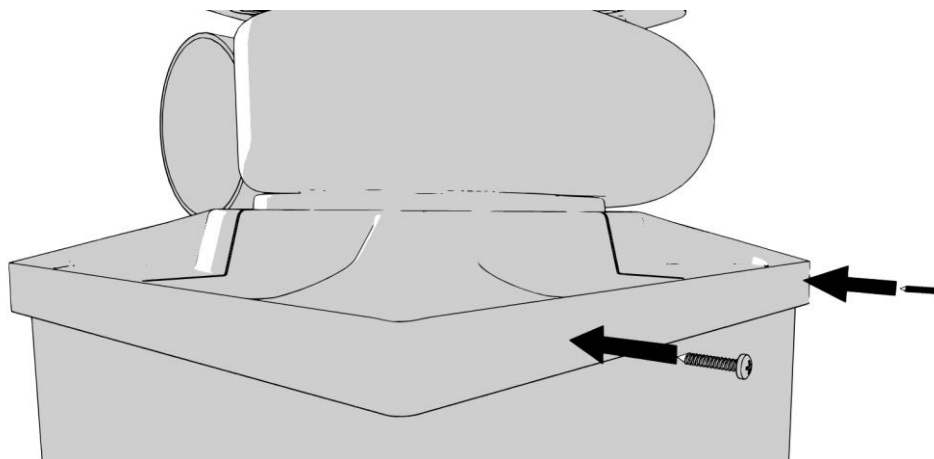

6. Ensure that the blower is properly secured before running.

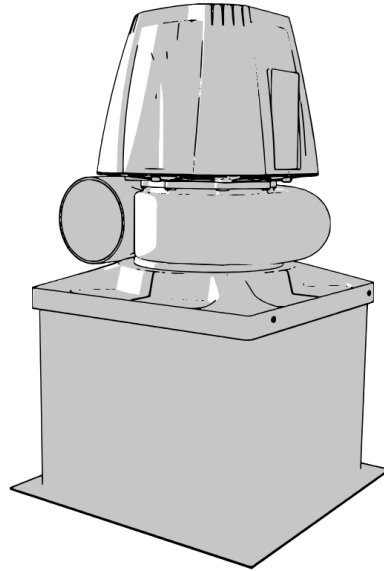

9.4.3 Wall Bracket Installation

1. Secure the wall bracket in the desired location before installing the blower on top of the wall bracket.

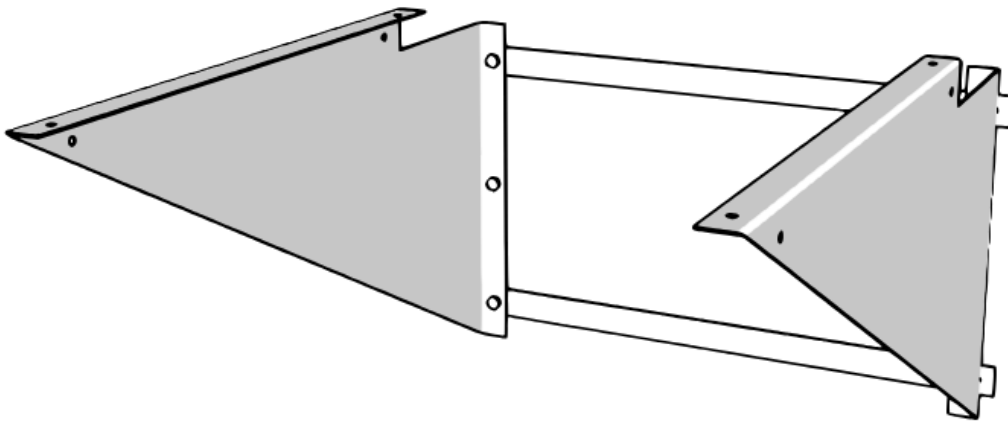

2. Place the Roof Kit Unit on the Wall Bracket. Ensure that the wall bracket is seated properly within the roof cap base of the Roof Kit Unit.

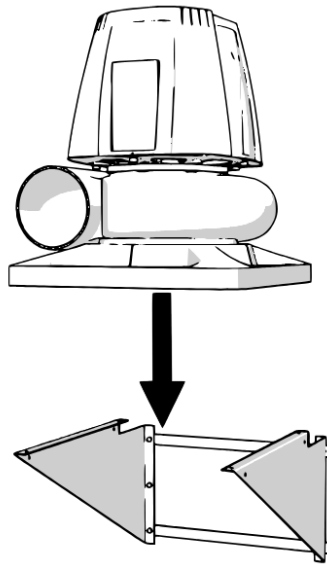

3. Drill holes into the roof kit unit base through the two side holes in the wall bracket. Do this for both sides.
4. Secure the Roof Kit Unit using stainless steel bolts through the previously drilled holes.

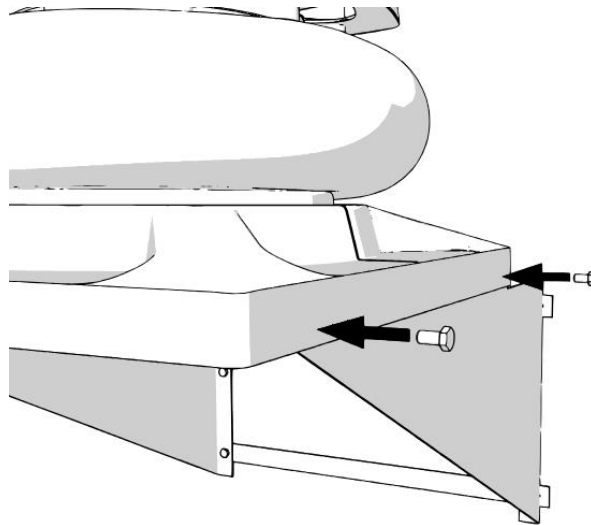

5. Secure the bolts with corresponding nuts.

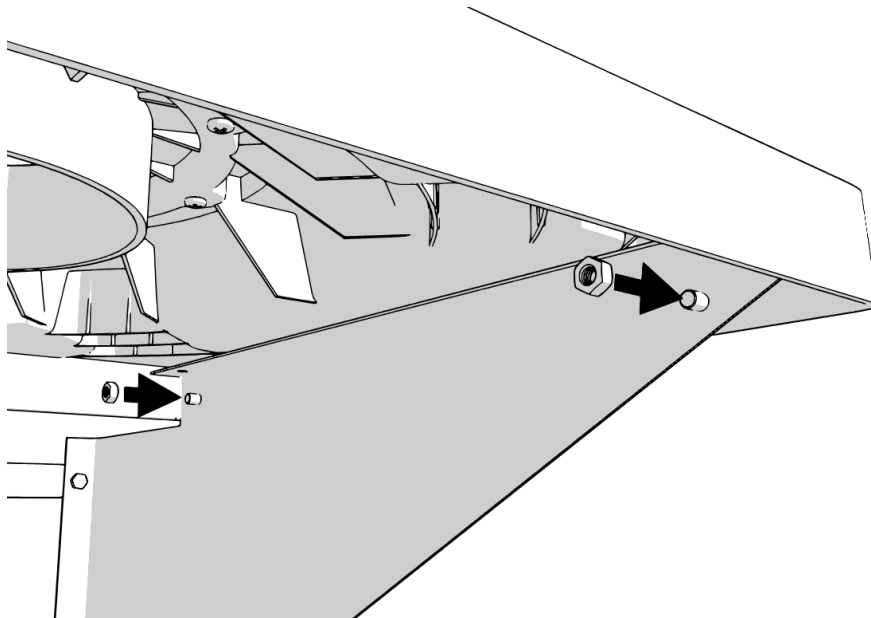

6. Ensure that the blower is properly secured before running.

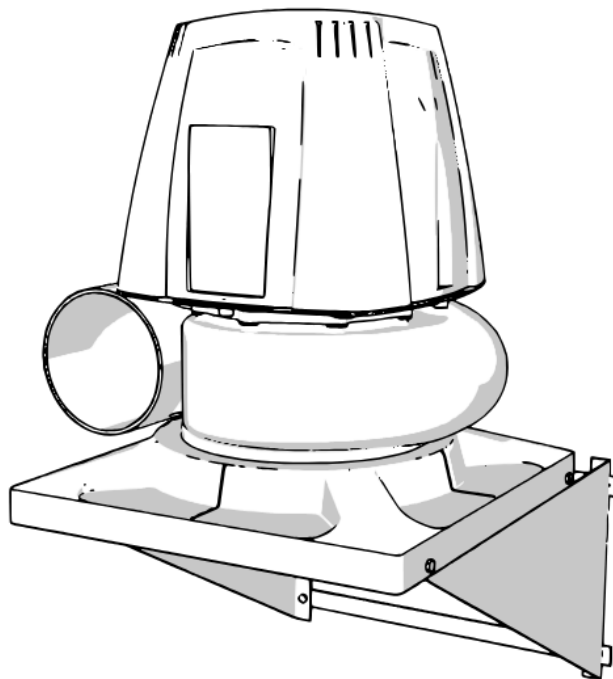

9.5 Speed Nozzle

9.5.1 Installation

1. Secure the blower in the desired location before installing the speed nozzle onto the blower. If using the metal support stand, secure by using the pre-drilled holes in the corners of the support stand feet.

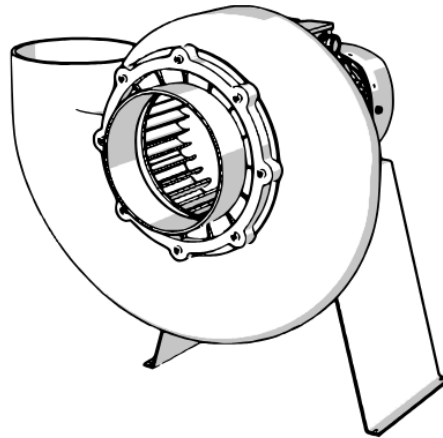

2. Place the speed nozzle over the blower outlet. The speed nozzle should slide smoothly onto the blower outlet.

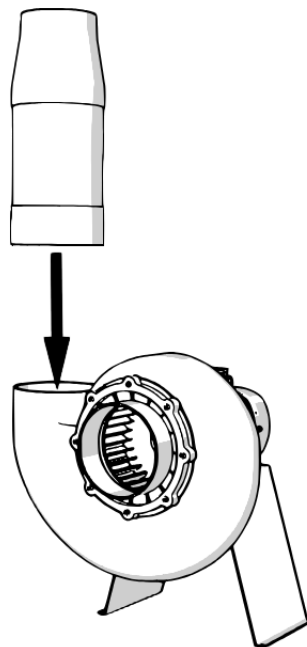

3. Secure the speed nozzle to the blower outlet. Drill four evenly spaced holes through the speed nozzle and into the blower outlet. Insert screws into the holes to secure the speed nozzle.

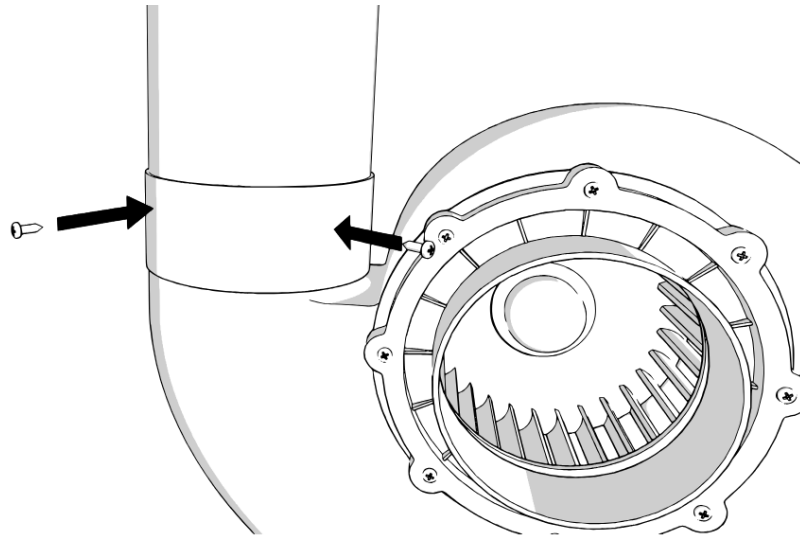

4. Ensure that the speed nozzle is properly secured before starting the blower.

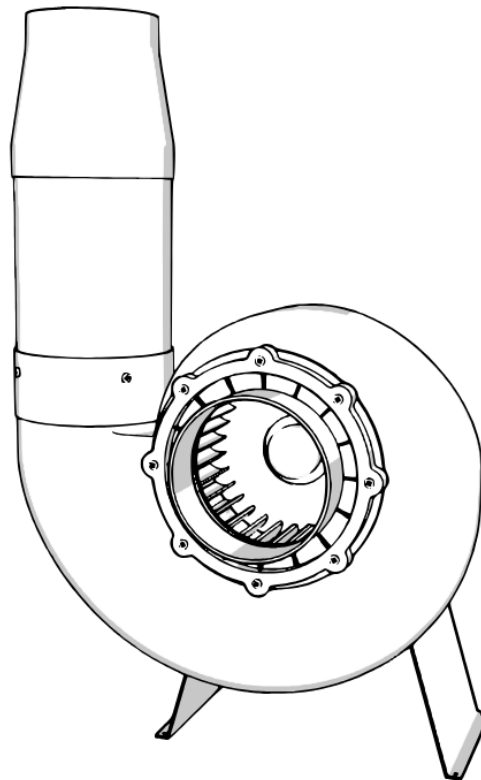



10 Test & Start Procedures

10.1 Test & Normal Start Procedures

WARNING: Do not insert your hands or arms in the fan while it is running.

It is highly recommended to insert an exhaust cap on the outlet and a six feet duct on the inlet flange to avoid accident or aspiration of hand, arm, or clothes when the fan is running. Do not wear a scarf close to the fan when it is running to avoid accidental choking and potential death.

Disconnect power before servicing the unit. Make sure that the power is turned off and locked in the OFF position.

Check that fan/blower is securely attached to the mounting location and that the mounting location is also secure. This unit should not vibrate when operating! Check clearances and all mounting hardware and secure as required.

All fans have sealed for life ball bearings and do not require lubrication. Running the unit for 15 to 20 minutes will ensure lubricant thoroughly mixed with the bearings and operate at optimum quietness.

When power is applied to the unit, check for proper rotation of fan wheel/impeller. Most motors allow for reverse rotation and if the fan wheel/impeller is moving in the wrong direction, air performance will be greatly affected. Reverse rotation for a prolonged period may cause motor damage that could void the warranty. Check the motor wiring diagram for proper wiring.

Electrical input check should be performed with fan properly loaded (pressure drop) to assure motor name plate amps are not exceeded. Never run a fan at free air.

Do not open the terminal box before turning off the power.

Check fan RPM against motor name plate to verify correct performance.

The fans are factory tested and checked for vibration, so this type of balancing is not required. Vibration could be caused by rough handling during shipment, installation, and weak foundations. Correct as required.



10.2 VFD Start Procedures

Before starting, ensure that all the parameters in the VFD are correctly set for the motor. This will allow the motor to operate at optimum conditions and prevent premature wear on the motor. Failure to do so may also result in excessive noise and whining noise from the motor.

Verify that the VFD ramp-up speed is set appropriately for the blower being used. It is recommended to have a slower ramp-up speed for larger blowers to reduce wear on the motor.

Check all connections between the VFD and the motor and verify that the connections are properly seated in the correct positions.

Check that fan/blower is securely attached to the mounting location and that the mounting location is also secure. This unit should not vibrate when operating! Check clearances and all mounting hardware and secure as required.

When the VFD is started, check for proper rotation of fan wheel/impeller. Most motors allow for reverse rotation and if the fan wheel/impeller is moving in the wrong direction, air performance will be greatly affected. Reverse rotation for a prolonged period may cause motor damage that could void the warranty. Some VFDs also have a reverse function to easily reverse the rotation of the motor. Otherwise, refer to the 12.3 *Troubleshooting Procedures* for reversing the rotation of the motor.

11 Troubleshooting/Maintenance/Repair

Before performing any maintenance on the fan, be sure power is turned off and locked in the off position at the service entrance.

Ventilators should be carefully checked at least once a year. For critical or rugged applications, a routine check every two or three months is suggested.

All motors carry a one-year warranty from the date of shipment. For repairs within the warranty period, the motor must be taken to the motor manufacturer's authorized service dealer. Contact your representative for additional warranty details.

A periodic motor check should consist of spinning the motor shaft with the power off to be sure the motor turns freely, and the bearings run smoothly.

The motor cooling fan and guard should also be maintained by checking and cleaning accumulated dust and debris.

The rotating wheel or propeller requires enhanced attention since materials in the air being handled can build up on blades to cause destructive vibration or weaken the structure of the propeller by corroding and /or eroding the blades. Regular inspection and corrective action



at intervals determined by the severity of each application are essential to good service life and safety.

WARNING: Failure to comply with the above-mentioned maintenance schedule may result in catastrophic failure of equipment. Said failure may include physical damage, shrapnel, electrical short, equipment damage, overheating, fire, property damage and other dangerous conditions.

11.1 Maintenance Schedule

Before performing any maintenance on the fan, be sure power is turned off and locked in the off position at the service entrance.

Ventilators should be carefully checked at least once a year. For critical or rugged applications, a routine check every two or three months is suggested.

All motors carry a one-year warranty from the date of shipment. For repairs within the warranty period, the motor must be taken to the motor manufacturer's authorized service dealer. Contact your representative for additional warranty details.

A periodic motor check should consist of spinning the motor shaft with the power off to be sure the motor turns freely and the bearings run smoothly.

The motor cooling fan and guard should also be maintained by checking and cleaning accumulated dust and debris.

The rotating wheel or propeller requires enhanced attention since materials in the air being handled can build up on blades to cause destructive vibration or weaken the structure of the propeller by corroding and /or eroding the blades. Regular inspection and corrective action at intervals determined by the severity of each application are essential to good service life and safety.

WARNING! Failure to comply with the above-mentioned maintenance schedule may result in catastrophic failure of equipment. Said failure may include physical damage, shrapnel, electrical short, equipment damage, overheating, fire, property damage and other dangerous conditions.

IMPORTANT! If replacing parts on a blower, use original spare parts from PLASTEC Ventilation only. When ordering spare parts, please specify the serial number or model number of the fan. This can be found on the fan nameplate. It is recommended to speak to a sales representative or technical representative to determine the necessary parts required.



Maintenance Activity	Annually	Every six Months	Quarterly
Check the blower housing, motor flange, and inlet flange for damage.	X		
Check the impeller for damage and imbalance.	X		
Clean the impeller and fan housing interior.		X	
Check the inlet flange and motor plate screws for corrosion and damage. Check that the screws are properly seated.	X		
Check that the fan inlet is clear and not blocked.		X	
Check the power and current consumption of the motor. Verify with the motor nameplate or spec sheet.			X
Check that cables and electrical connections are properly seated and there is no damage to the wires, clamps, or connections.	X		

WARNING! Before cleaning the fan, ensure that the impeller is at a complete stand still and that any disconnect switches are switched to the OFF position.

WARNING! Follow all safety precautions before approaching the fan. Only qualified individuals should be carrying out the cleaning of the fan.

WARNING! If the fan is responsible for transporting hazardous chemicals, pay attention to the safety data sheet of the chemical that is being transported. Wear the appropriate PPE for the chemical in question.

Do not use steel brushes, sharp-edged object, or high-pressure cleaners when cleaning the fan.

Do not bend the impeller blades when cleaning. Any damage to the impeller from cleaning may result in excessive vibration or further damage to the impeller or fan.

When cleaning the housing, ensure that any debris or built-up dirt is cleared. Ensure that the inlet and outlet are completely clear to allow for maximum performance.



11.2 Common Questions

Question	Answer
How can I tell if I need to run a Clockwise (CW) or Counterclockwise (CCW) configuration?	See section 7.2 <i>Installation Orientations</i>
Can I use a VFD or Speed controller on a single-phase motor?	It is not recommended to use a speed controller with a single-phase motor as it can cause damage to the motor due to increased amperage draw. It is not possible to use a VFD for a single-phase motor.
What are the additional wires/terminals on the explosion-proof motors for?	The additional wires or terminals are for the built-in thermal protection system in these motors. To use these, it will require the use of an additional thermal overload relay system.



11.3 Troubleshooting Procedures

Problem	Possible Causes	Solution
Low Airflow	Impeller Rotates in wrong direction	Change direction of rotation for motor (Swap two phases for three phase motors).
	Incorrect Impeller in Use	Verify correct impeller is in use for direction. Inspect ring on impeller to determine impeller direction (Blue – CCW, Red – CW). Check 7.3.3 <i>Counterclockwise and Clockwise Conversions</i> for instructions to change impeller.
	Wrong Wiring Configuration (Single Phase Motors)	Check 8 <i>Single Phase Motors</i> , for correct wiring configuration. Ensure that wiring configuration matches the direction of the housing. Check 7.2 <i>Installation Orientations</i> for housing direction.
	Intake or Outlet blocked/Ducting blocked	Remove blockage. Check for excess dirt or debris within the system. Remove dirt or debris if present.
	Dampers not or only partially open	Check Dampers, adjust damper plate to allow for larger opening.
	Pressure Losses too high	Check that Dampers are open and/or filters are not clogged. Ensure that the blower is not undersized for application/selection. If undersized, return and select appropriate blower or optimize duct routing.
Electronics/Motor overheated	Insufficient Cooling	Check that motor is not insulated. If insulated, remove insulation to restore cooling.
	Cooling Fan is broken	Contact PLASTEC Ventilation for replacement motor cooling fan.
	Use of Speed Controller on Single Phase Motors	If a speed controller is being used on a Single Phase Motor, it will increase the motor amperage draw when reducing speed and thus overheat motor. Remove speed controller and add adjustable damper for flow control.
	Motor is Locked	Check that the impeller can rotate freely. If not, motor may have seized. Contact PLASTEC Ventilation about replacement motors.
	Overloaded Motor	Check if the blower is correct for the application/selection. Blowers that are oversized can overheat from too much flow. Add a damper or VFD (Three Phase Motors only) to



		reduce flow or control speed. Flow reduction will reduce amperage draw.
Motor does not rotate	Faulty supply voltage	Check supply voltage. Check that motor is receiving the correction voltage.
	Improper power supply connection	Ensure that all connections are properly seated in the motor junction box.
	Bearing have Seized	Check that the impeller can rotate freely. If not, the bearings may have seized and locked the motor. Contact PLASTEC Ventilation about replacement motors.
Excessive Vibration/Fan not running smoothly	Impeller Imbalance	Contact PLASTEC Ventilation about a replacement Impeller or Impeller exchange.
	Dirt or debris build-up on Impeller	Carefully remove dirt or debris from Impeller. Ensure that the Impeller is not damaged before running blower again.
	Damage to Impeller from debris or excessive temperature	Contact PLASTEC Ventilation about a replacement Impeller
	Damage to Impeller due to Material Incompatibility	Contact PLASTEC Ventilation about a replacement Impeller