

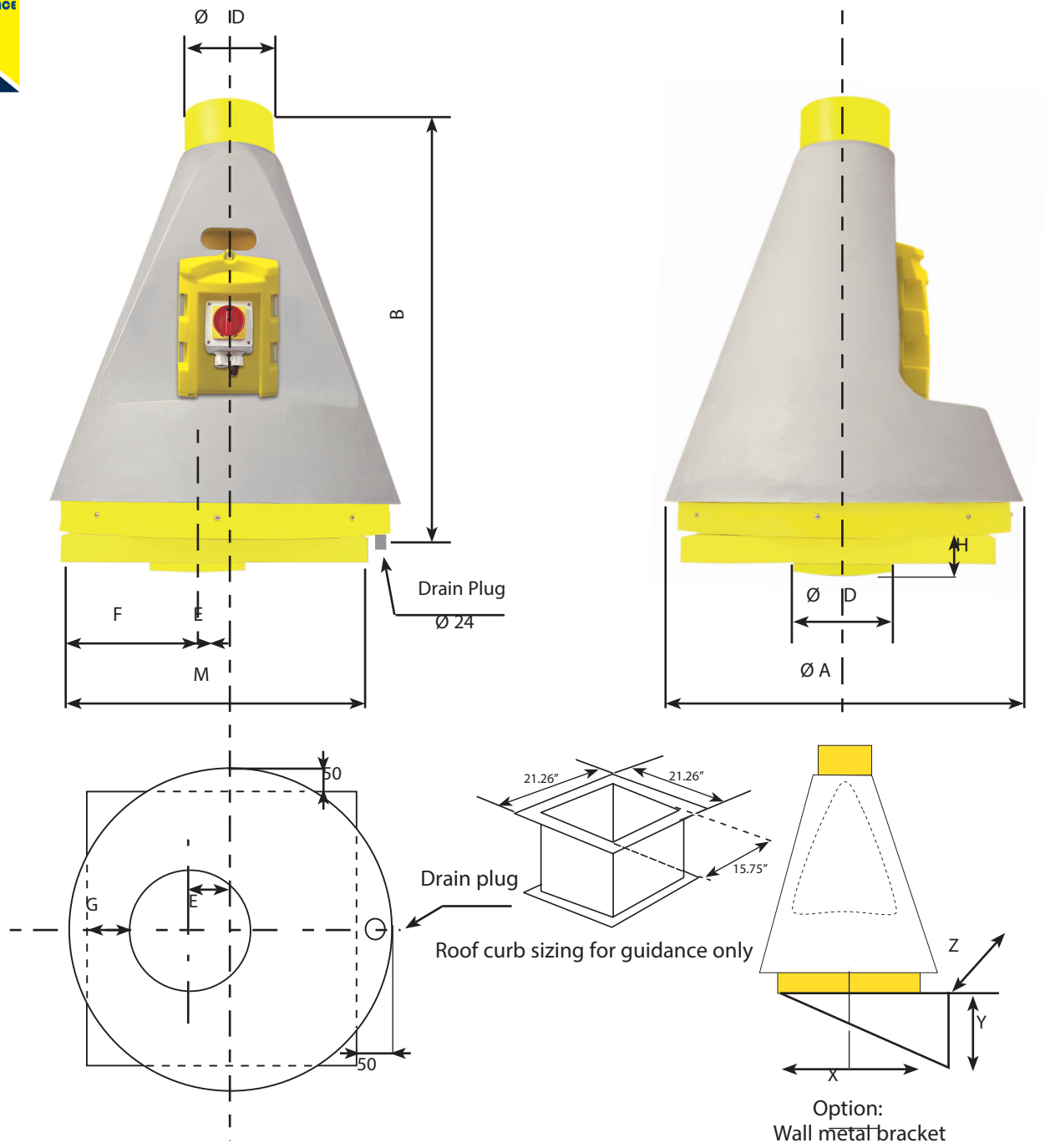

JET 20

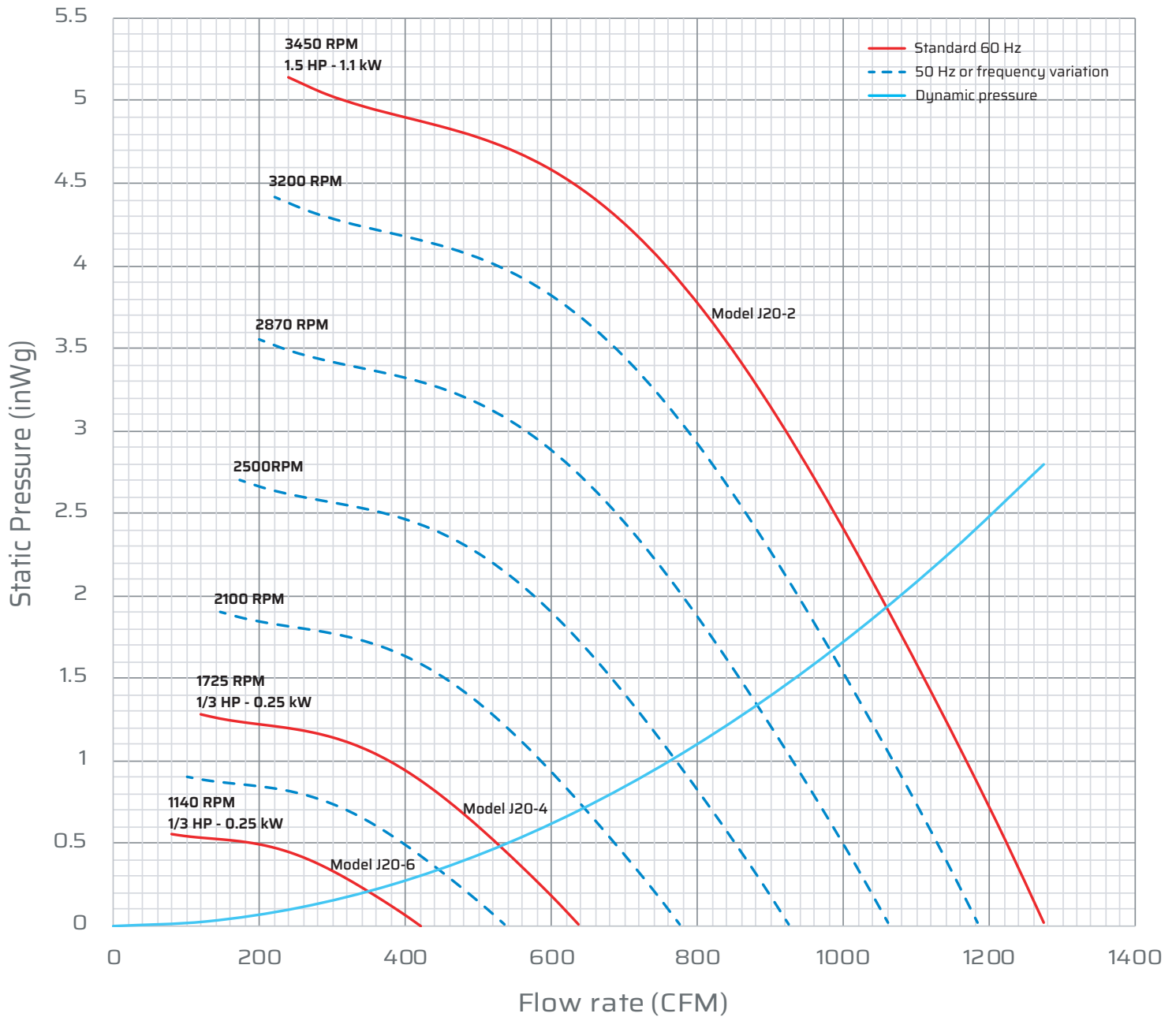

Dimensional data (inches)											
A	B	Ø D	E	F	G	H	X	Y	Z	M	
23.62	31.50	6.30	1.97	9.84	6.30	2.76	11.02	13.78	15.75	21.26	



Inlet sound

	Q _v	SP	L _{wA}	L _{pA} *	Octave band (Hz)							
RPM	(CFM)	(inWg)	dB(A)	dB(A)	63	125	250	500	1000	2000	4000	8000
1725	330	1.07	69	49	65	70	69	67	65	58	56	49
3450	654	4.28	84	64	80	85	84	82	80	73	71	64

* Acoustic pressure L_p at 10 feet - Outlet acoustic data available on request