



TXTRB10BB

Subwoofer Enclosure Port Module

Attaching the Port:

Unscrew the eight #2 Philips speaker mounting screws and remove the subwoofer from the TXTRB10 subwoofer enclosure.

Unscrew the side panel from the TXTRB10 subwoofer enclosure using 4mm and 5mm Allen wrenches. Push out the side panel from inside of enclosure.

Align and attach the foam gasket to TXTRB10BB (Port).

Align the TXTRB10BB (Port) next to TXTRB10 (Enclosure). Place a rubber washer on the four inner bolts. From inside the enclosure, align the four bolts through the enclosure into the threaded holes on the port. Tighten using a 10mm socket.

Install two additional bolts on the bottom side of the enclosure stand.

Reconnect the speaker wire from the TXTRB10 enclosure to the subwoofer the same way as before it was removed.

Reinstall the subwoofer using a #2 Philips screwdriver.

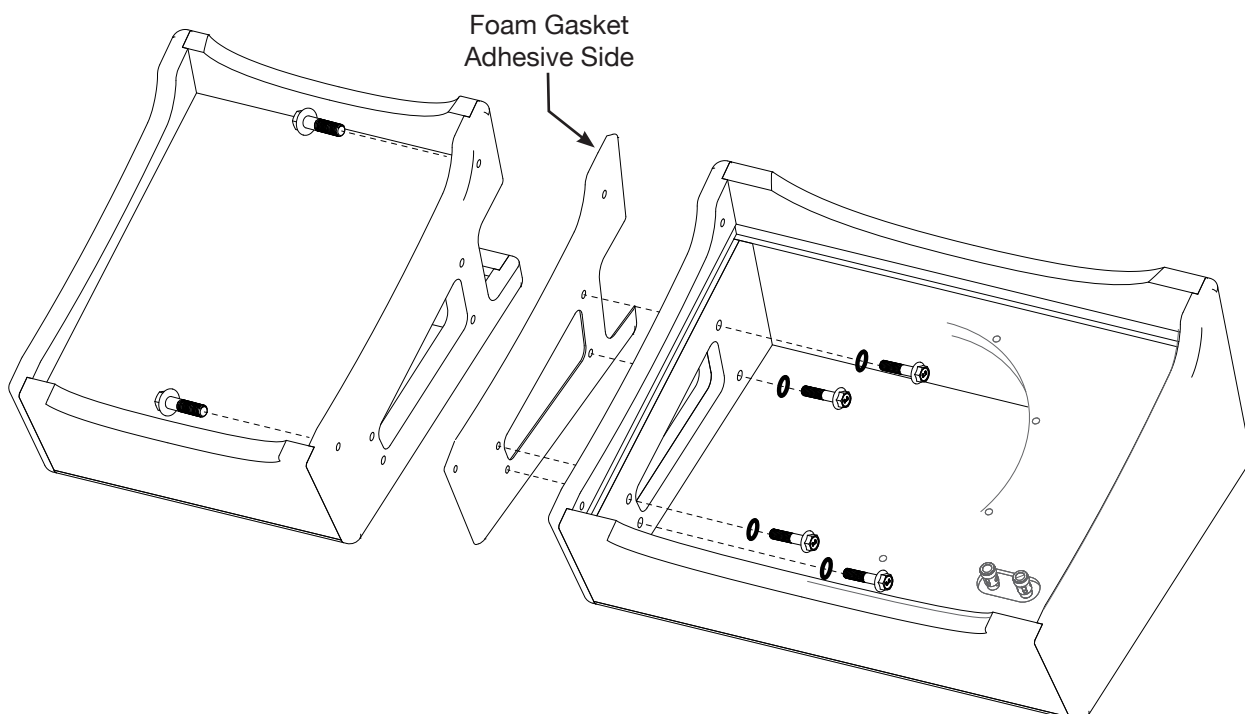
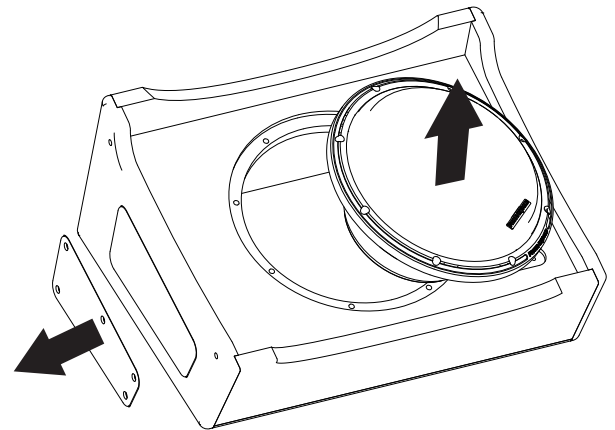

Limited Warranty

Stinger warrants this product to be free of defects in materials and workmanship for a period of one (1) years from the original date of purchase. This warranty is not transferable and applies only to the original purchaser from an authorized Stinger dealer in the United States of America only. Should service be necessary under this warranty for any reason due to manufacturing defect or malfunction, Stinger will (at its discretion), repair or replace the defective product with new or remanufactured product at no charge. Damage caused by the following is not covered under warranty: accident, misuse, abuse, product modification or neglect, failure to follow installation instructions, unauthorized repair attempts, misrepresentations by the seller. This warranty does not cover incidental or consequential damages and does not cover the cost of removing or reinstalling the unit(s). Cosmetic damage due to accident or normal wear and tear is not covered under warranty.

INTERNATIONAL WARRANTIES:

Products purchased outside the United States of America are covered only by that country's Authorized Stinger reseller and not by Stinger. Consumers needing service or warranty information for these products must contact that country's reseller for information.



Stinger is a Power Brand of AAMP Global
15500 Lightwave, Clearwater, Florida 33760
Phone: 888-228-5560

Technical Support

Phone: 727-592-5991

Email: support@stingerelectronics.com

Chat: [stingerelectronics.com](https://www.stingerelectronics.com)

IG-TXTRB10BB REV 101921

© 2021 AAMP Global. All rights reserved.