

Aquarium Co-Op Auto Feeder Instructions

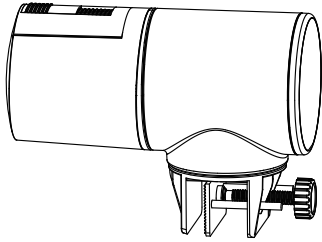

Note:

- Do not attempt to disassemble. Disassembling will void the 1-year warranty.
- Do not submerge this unit in water.
- Unit charges through a USB Micro B connection.
- Manual feedings can be initiated by pressing the “Feed” button.
- Charge times for the unit are typically 3 hours to achieve a full charge.
- Fully charged units can run for 3 to 6 months on a single charge

Setting the Auto Feeder Time Clock:

1. Power the unit on by pressing and holding the “Power” button for 3 seconds.
2. Press and hold the gear program button for 3 seconds to enter the time clock adjustment mode. The hour number will flash.
3. Press the up or down arrow button until the desired hour number (AM or PM) is shown.
4. Press the gear program button to advance to make adjustments to the minute number.
5. Press the up or down arrow button until the desired minute number is shown.
6. When the appropriate time is displayed, press the “Feed” button to accept the current time.
7. To program feeding times press the gear program button when the minute number is flashing to enter the feeding time program mode.

Mounting the Auto Feeder:

Flat Surface Mounting:

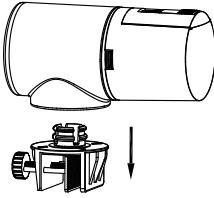
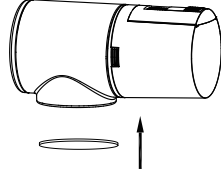
- 
1. Remove the clamp base by pulling straight down from auto feeder unit
- 
2. Apply the supplied adhesive pad to the underside of the auto feeder unit

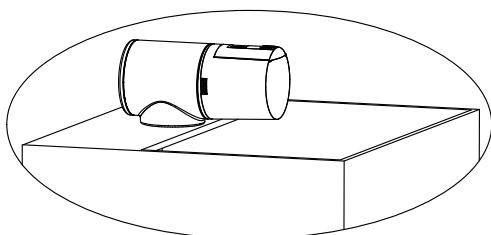

3. Apply firmly to clean surface for best adhesion

Aquarium Rim Mounting:

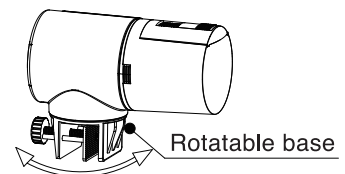
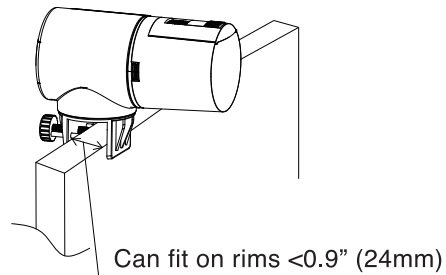

Setting the Feeding Time and Number of Food Drum Rotations:

The Aquarium Co-Op Auto Feeder is capable of 4 programmed feedings per day. Each feeding can be set to feed with 1, 2, or 3 rotations of the feeding drum.

1. Power the unit on by pressing and holding the "Power" button for 3 seconds.
2. Press and hold the gear program button for 3 seconds to enter the time clock adjustment mode. The hour number will flash.
3. If time clock adjustments are required, follow steps 3 through 7 above in the Auto Feeder Time Clock setting section. If no time changes are required, press the gear program button 2 times until the first feeding block and hour number are flashing.
4. Press the up or down arrow button until the desired hour (AM or PM) feeding time for the first feeding is shown. Press the gear program button to advance to the first feeding minute number is flashing.
5. Press the up or down arrow button until the desired minute feeding time for the first feeding is shown. Press the gear program button to advance to the first feeding drum rotation block.
6. Press the up or down arrow button until the desired number of drum rotations for the first feeding is shown. *Note* that there are 4 options for each feeding block. 1 = one drum rotation, 2 = two drum rotations, 3 = three drum rotations, and no number shown = zero drum rotations.
7. Press the gear program button to advance to the second programmed feeding time. The hour number and second feeding drum rotation block will both be flashing.
8. Repeat steps 4 through 6 to program the second feeding time and number of feeding drum rotations.
9. Repeat step 7 to proceed to the third programmed feeding time.
10. Repeat steps 4 through 6 to program the third feeding time and number of feeding drum rotations.
11. Repeat step 7 to proceed to the fourth programmed feeding time.
12. Repeat steps 4 through 6 to program the fourth feeding time and number of feeding drum rotations.

At any time during programming you can press the "Feed" button to save the current settings and exit to the main display.

NOTE – To delete all programmed feeding times and drum rotation settings, press and hold the down arrow button for 5 seconds. This can NOT be undone.

