

# Bench**BUD**

Adjusts to All Users & Projects in Seconds

## Battery Pack Workbench Assembly Instructions

### TABLE OF CONTENTS

Page 2 › Basic Safety Instructions

Pages 3 - 11 › Base & Worksurface Assembly

Pages 12 - 20 › Base Only Assembly  
Maximum Worksurface Sizes

Pages 21 - 22 › Programmable Switch  
Set Up & Reset Procedures  
Connect to Mobile App  
Mechanical Reset Mode

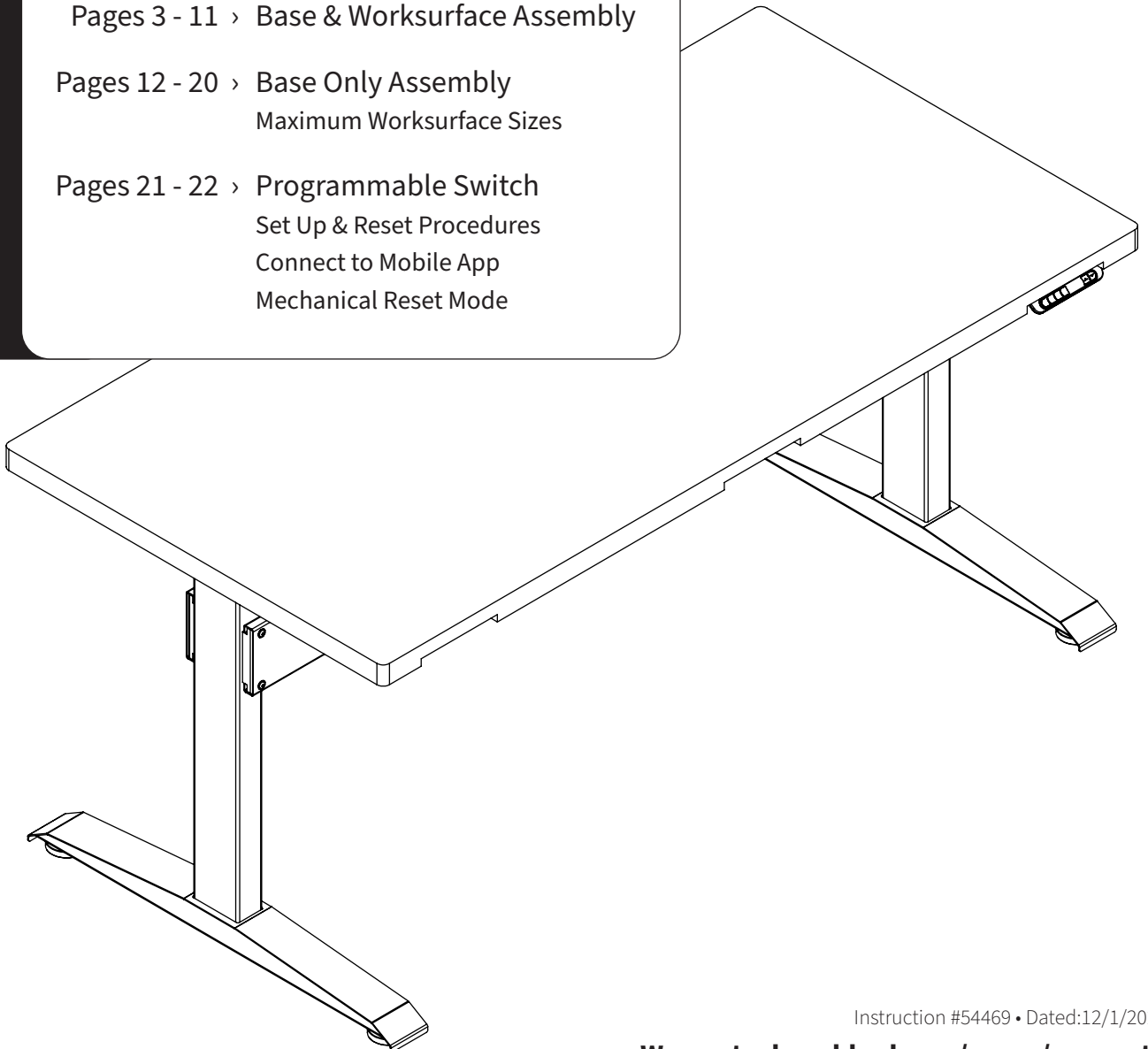

Instruction #54469 • Dated:12/1/2021

Warranty: [benchbud.com/pages/warranty](https://www.benchbud.com/pages/warranty)

**READ ALL INSTRUCTIONS BEFORE USING THIS PRODUCT.**



**WARNING**

**USE THIS PRODUCT ONLY AS INSTRUCTED.  
FAILURE TO COMPLY WITH ALL INSTRUCTIONS AND WARNINGS  
MAY RESULT IN SERIOUS PROPERTY DAMAGE OR BODILY INJURY.**

**Basic Safety Instructions**

- 1. Intended Use.** This Product is exclusively designed for use as an indoor workbench in compliance with all instructions and safety warnings in the user manual. Any different use, or use extending beyond the intended use, may result in property damage or bodily injury and is prohibited. This Product should not be used, operated or maintained with additional components not authorized by BenchBUD & K&A Manufacturing, Inc.

**BY USING THIS PRODUCT OR ANY FEATURE OF THIS PRODUCT, YOU AGREE TO COMPLY WITH ALL PRODUCT TERMS AND POLICIES, INCLUDING WITHOUT LIMITATION ANY SAFETY WARNINGS AND INSTRUCTIONS, PROVIDED BY K&A MANUFACTURING, INC. AND ITS AFFILIATES. K&A MANUFACTURING, INC. SHALL ASSUME NO LIABILITY FOR ANY DAMAGE OR INJURY CAUSED BY USE OF THE PRODUCT A) IN VIOLATION OF ANY SAFETY WARNINGS OR INSTRUCTIONS; B) NOT AUTHORIZED BY K&A MANUFACTURING, INC.; OR C) BY EVENTS BEYOND K&A MANUFACTURING, INC.'S CONTROL.**



**DANGER**

**DO NOT SIT, STAND OR CRAWL ON OR UNDER THE PRODUCT.  
MAKE SURE NO OBSTACLES ARE IN THE PRODUCT'S PATH.  
MAKE SURE ALL CORDS ARE LONG ENOUGH TO ACCOMMODATE ANY CHANGE IN HEIGHT.  
DO NOT USE ATTACHMENTS NOT RECOMMENDED BY THE MANUFACTURER.**

- 2. Electrical Height Adjustment.** The height of this Product may be adjusted electronically. Contact with electrical voltage may cause serious injury and death. Only use the Product in compliance with these instructions. This Product should not be used in environments with high levels of humidity or moisture.



**KEEP CORDS AND ELECTRICAL COMPONENTS AWAY FROM HEAT AND LIQUIDS.  
DO NOT OPEN ANY OF THE COMPONENTS: CONTROL BOX OR KEYPAD.  
DO NOT USE WITH A DAMAGED PLUG OR CORD.  
DO NOT INSERT ANYTHING INTO ANY SEAM OR OPENING.**

- 3. Setup and Use.** This Product should only be used and operated in good condition. When in use, no one should sit, stand or crawl on or under the Product. There is a danger of crushing, shearing, injury or damage. Keep the entire range of motion of the Product clear of all obstacles. Devices and object on the Product can tip over, fall or be crushed by the Product.



**KEEP HANDS AND FINGERS CLEAR.  
KEEP ALL OBSTACLES CLEAR OF THE PRODUCT'S PATH.**

- 4. Users.** This Product is not intended for use with children, individuals with restricted physical, sensory or mental capabilities, or individuals who lack experience or knowledge, unless they are supervised by a person who is responsible for their safety or they have received instructions from a person who is responsible for their safety concerning how the Product must be used. Children should be closely supervised to ensure that they do not play with the Product and its height adjustment mechanism to avoid risk of physical injury or electric shock.



**KEEP CHILDREN AWAY FROM THE PRODUCT, ITS CONTROL UNITS, AND KEYPADS.**

# BenchBUD

Adjusts to All Users & Projects in Seconds

## Workbench Assembly Instructions

### BASE & WORKSURFACE

If you purchased both the **BenchBUD base** and **BenchBUD worksurface**, begin here to follow instructions (pages 3 - 11).

Reference pages 21 - 22 for switch programming, connecting to mobile app, and mechanical reset mode instructions.

If you purchased only the **BenchBUD base**, and you are utilizing **your own worksurface**, skip ahead to page 12 for BASE-ONLY instructions.

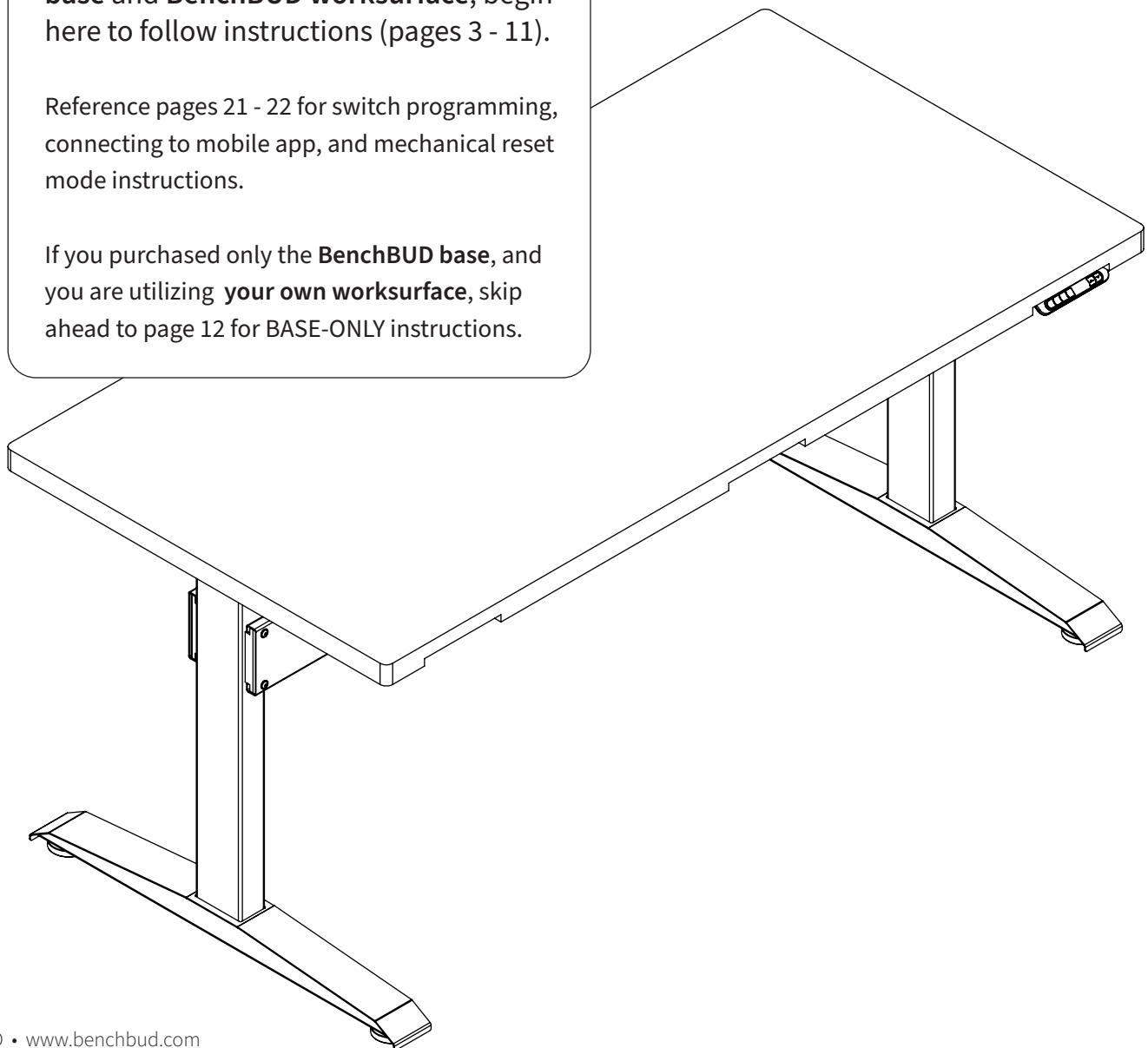

## Tools Required for Assembly

- A. Power Driver with Adjustable Torque
- B. Tape Measure
- C. #2 Phillips Head Driver Bit
- D. #2 Square Head Drive Bit **(Recommended)**

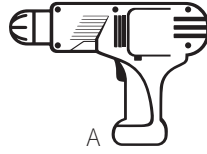

## Hardware and Tools Included for Assembly (may have extra)

- E. 5/8" Washer Head Wood Screw **x4**
- F. 1/4"x 5/8" Bolt **x4**
- G. Lock Washer **x4**
- H. 5/8" Wood Screw **x4**
- I. Cord Clip **x1**
- J. M6 x 10mm Bolt **x8**
- K. Star Washer **x8**
- L. Wire Management Channel **x1**
- M. 3/16" Allen Wrench **x1**
- N. 4mm Allen Wrench **x1**
- O. 6mm Hex Rod Wrench **x1**

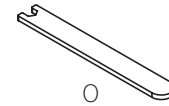
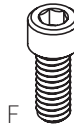

## BenchBUD Parts

- P. Cross Support **x2**
- Q. U-Channel **x2**
- R. Short Hex Rod **x2**
- S. Switch **x1**
- T. Control Box Housing **x1**
- U. Control Box Battery Pack **x1**
- V. Left Motor **x1**
- W. Right Motor **x1**
- X. Left Leg **x1**
- Y. Right Leg **x1**
- Z. Worksurface **x1**  
*(not pictured)*

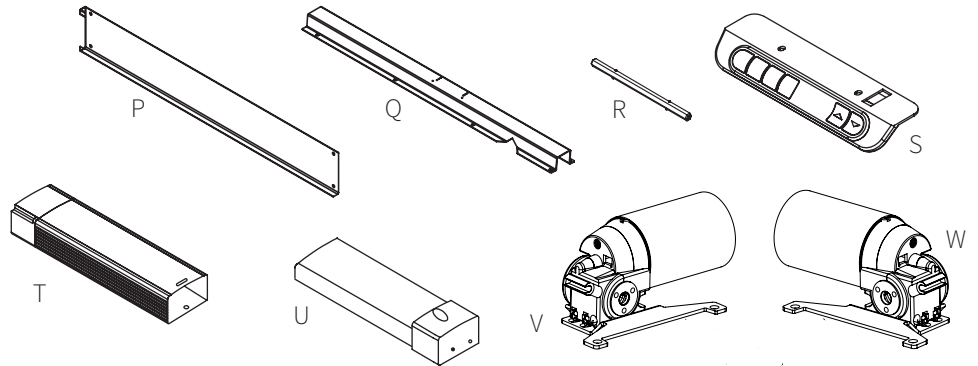

**Legs must be in their lowest position before installation.**

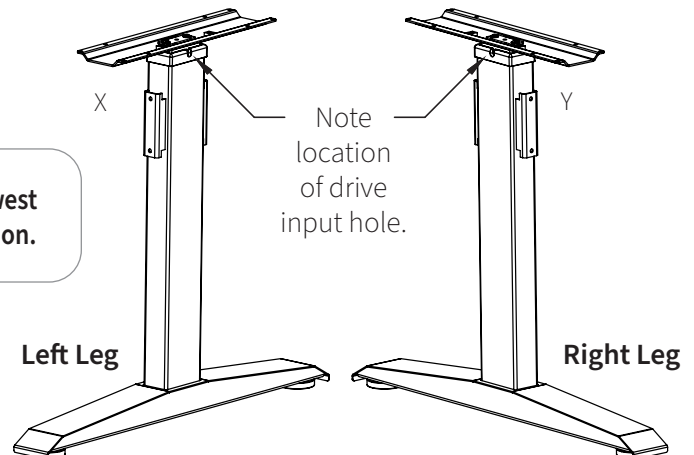

## Step 1



Lay the worksurface on a protected surface with pilot holes facing up.

**LEGS MUST BE IN LOWEST POSITION BEFORE INSTALLING HEX RODS.**

- Place the **left leg column (X)** onto the worksurface and align with predrilled pilot holes. Make sure leg is in its lowest position.
- Insert the short hex rod (R) through the **left motor assembly (V)** (insert starting at bracket side of the motor).
- Slide hex rod into left leg drive input hole. Hex rod should slide all the way into leg.
- If hex rod is not properly aligned with drive input, slightly rotate the motor 1/6th or 1/3rd of a turn.



Hex Rod Wrench (O) can also be used to rotate hex rod

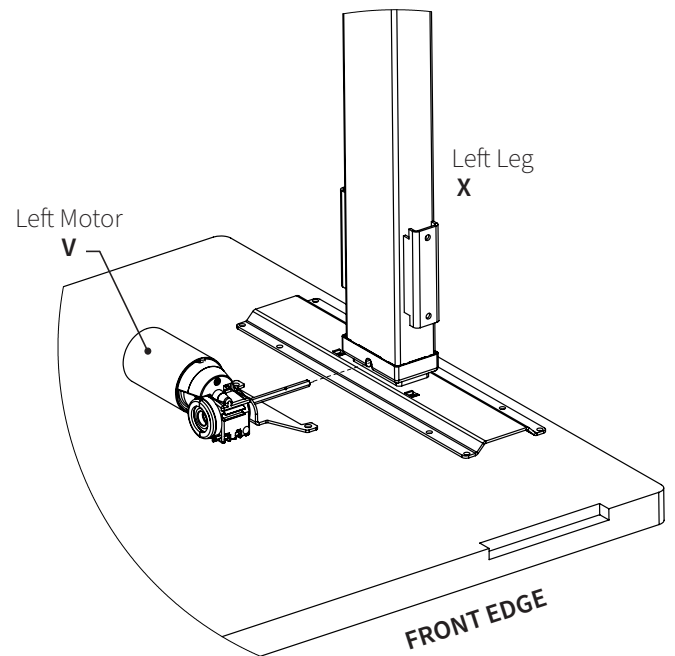
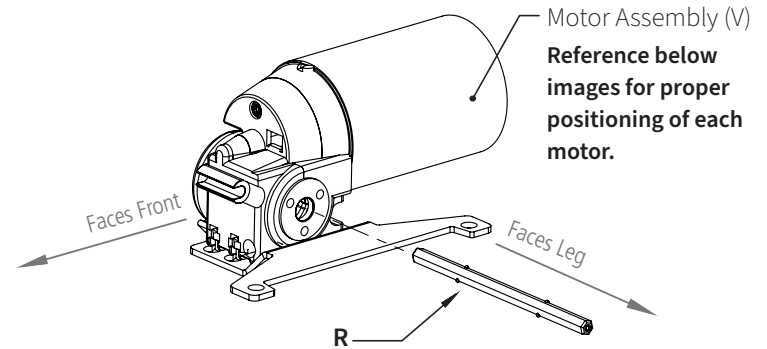
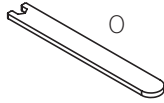

## Step 2

- Place the **right leg column (Y)** onto the worksurface and align with predrilled pilot holes. Make sure leg is in its lowest position.
- Insert the short hex rod (R) through the **right motor assembly (W)** (insert starting at bracket side of the motor).
- Slide hex rod into right leg drive input hole. Hex rod should slide all the way into leg.
- If hex rod is not properly aligned with drive input, slightly rotate the motor 1/6th or 1/3rd of a turn.



Hex Rod Wrench (O) can also be used to rotate hex rod

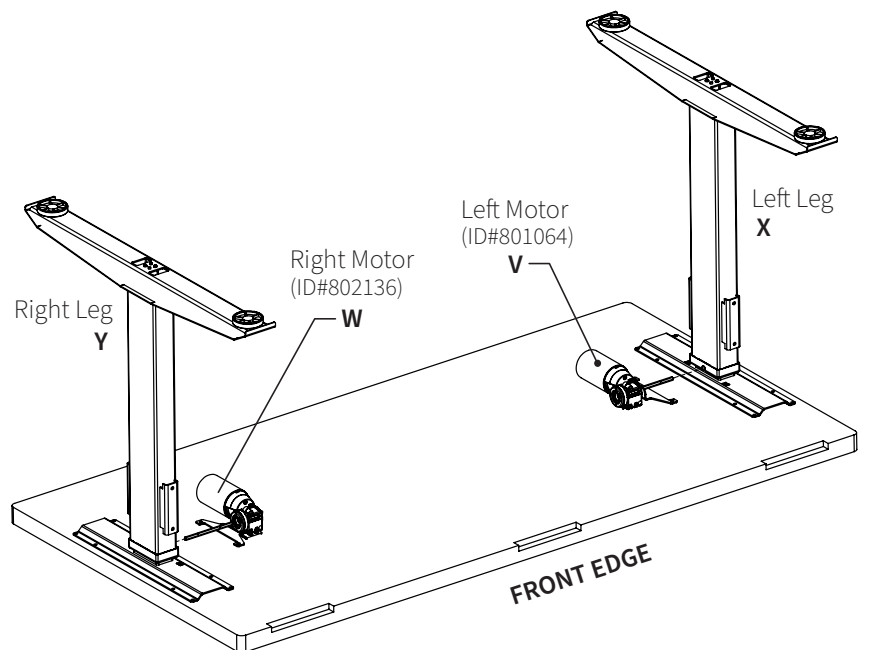
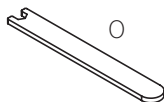

### Step 3

**Important:** Please be aware that 5/8" screws are provided. If your worksurface is 5/8" or thinner, you will need to supply your own hardware.

- After hex rods are installed, align **left motor bracket** and corresponding mounting holes on **left leg column (X)**.
- Position lock washers (G) and tighten motor mounting bolts (F).
- Repeat to attach **right motor bracket** to **right leg column (Y)**.

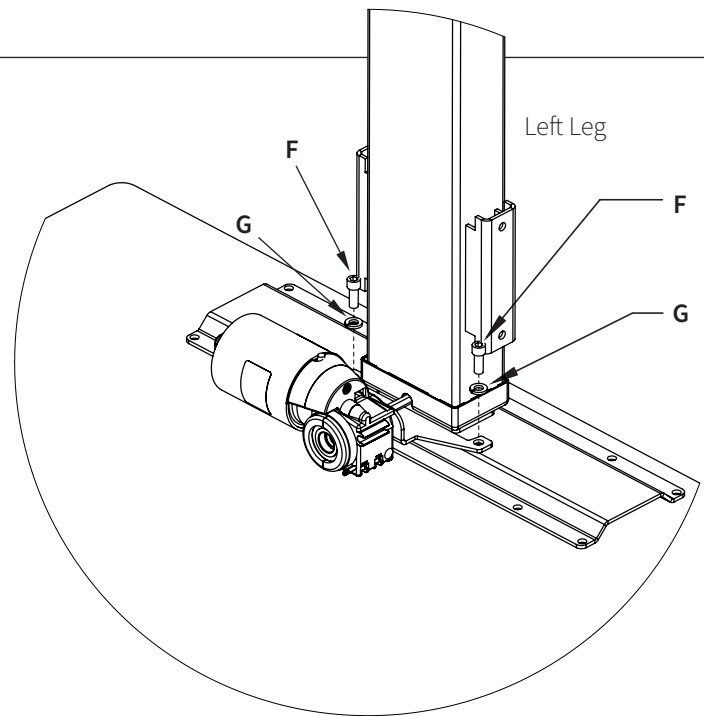
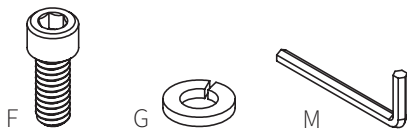

### Step 4

- Align the U-channel (Q) with the pre-drilled pilot holes\*.
- Make sure the end with the holes closest the edge faces towards the left leg.
- Attach U-channel to worksurface with washer head wood screws (E).
- **Do NOT fully tighten** until all screws are installed.

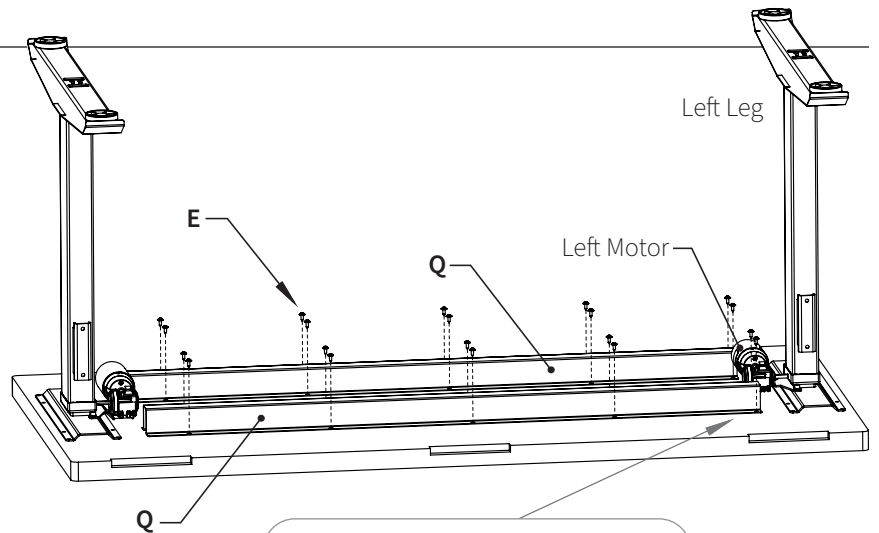
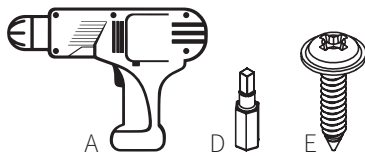

Holes closest to end of U-channel face left leg.



For proper alignment of pre-drilled holes, first insert screws at the four corners of the U-channel. Then, install the remaining screws.

\*Hole placement may vary depending on table width.

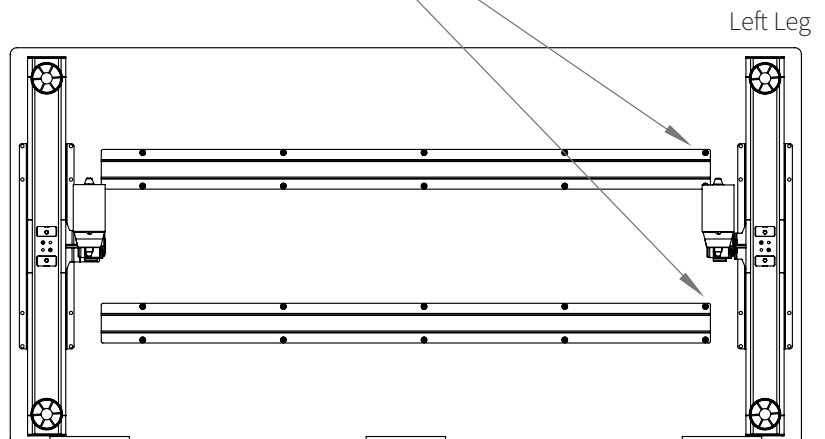

## Step 5

- Slide cross supports (P) over leg cross support brackets.

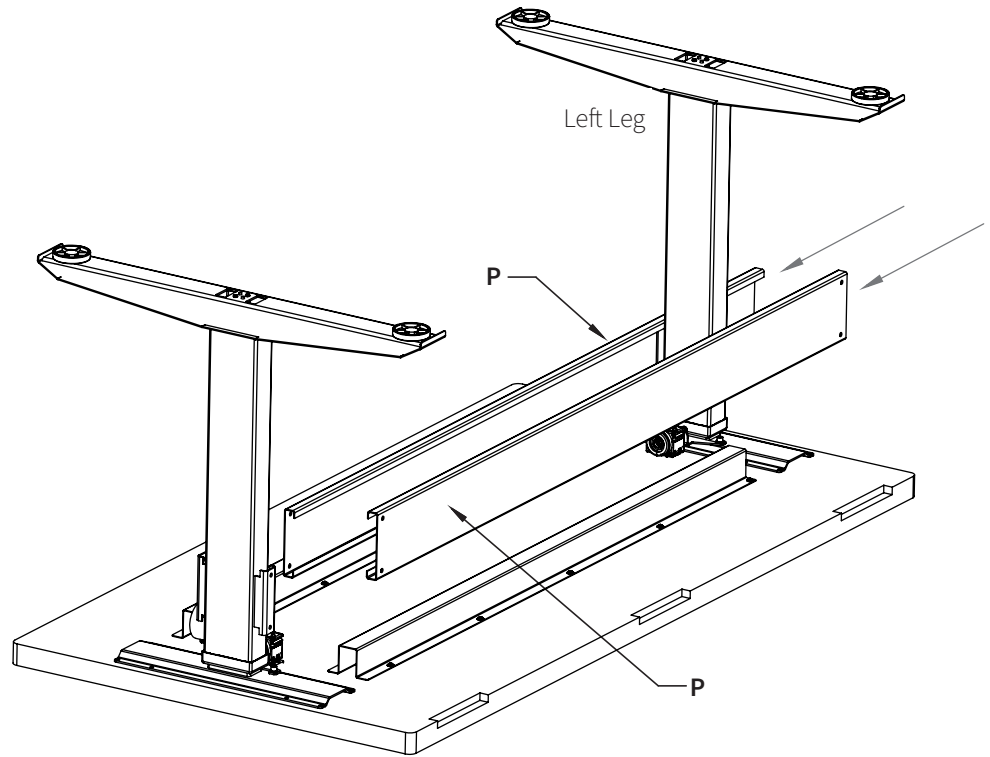

## Step 6

- Install bolts and washers (8 sets).  
**Do NOT fully tighten.**

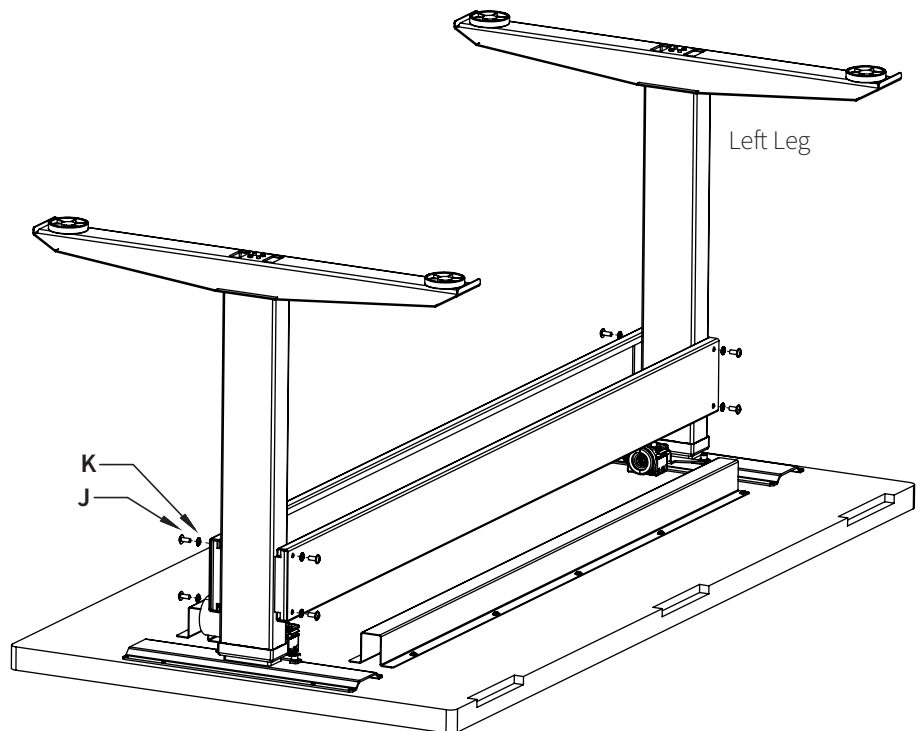
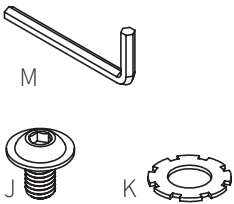

## Step 7

- Align assembled base with the pre-drilled pilot holes.
- Secure the base to the worksurface with washer head wood screws (E).
- **Do NOT fully tighten** until all wood screws are inserted.

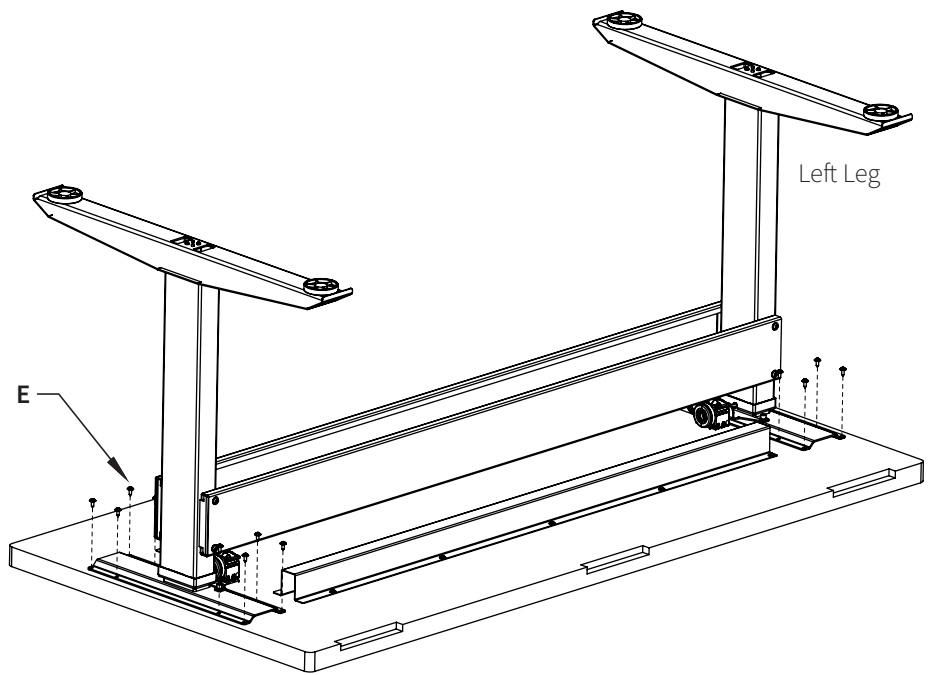
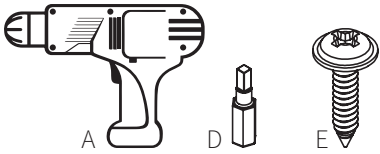

For proper alignment, first insert screws at the four corners of each leg mounting bracket. Then, install remaining screws.

## Step 8

- Fully tighten bolts in both cross supports.

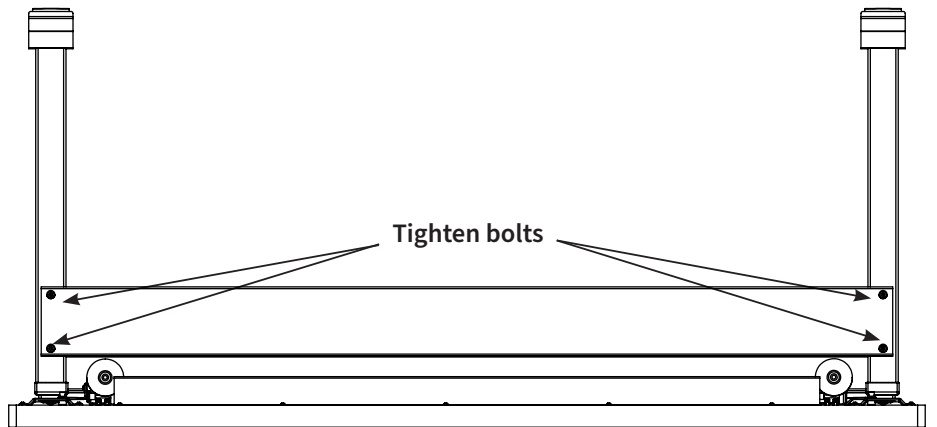



## Step 9

- Mount control switch (S) to worksurface using two wood screws (H).
- For standard install location, align switch with pre-drilled pilot holes.

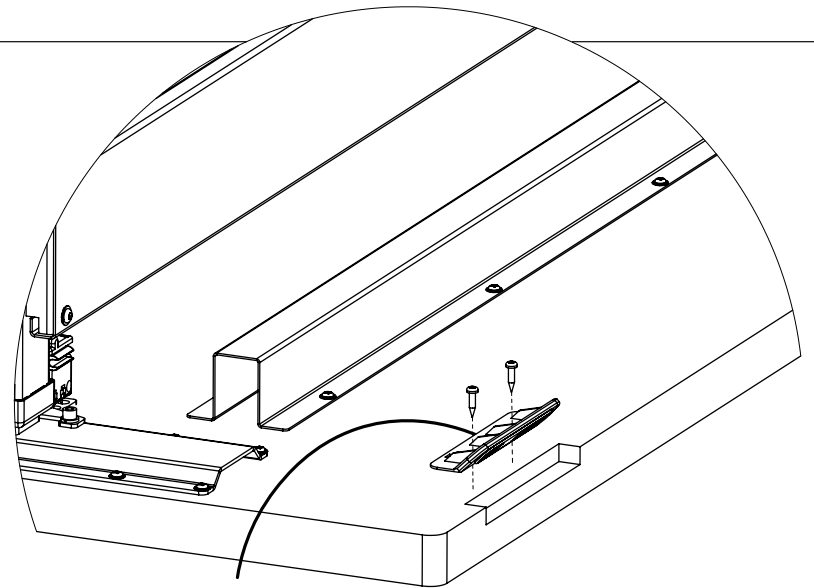
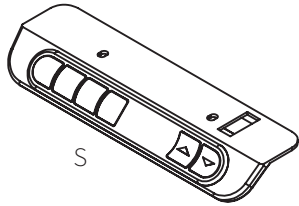
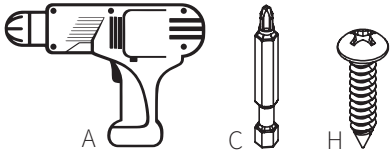

**NOTE:** Please refer to the installation instructions included with switch.

## Step 10

- Mount control box housing (T) to worksurface using two wood screws (H). The control box battery pack (U) cannot be inserted into the housing (T) yet.
- For standard install location, align control box with pre-drilled pilot holes. However, it can be installed in any location, wire lengths permitting.



**Required Orientation:**  
Long side of control box must run parallel to the long side of the worksurface.

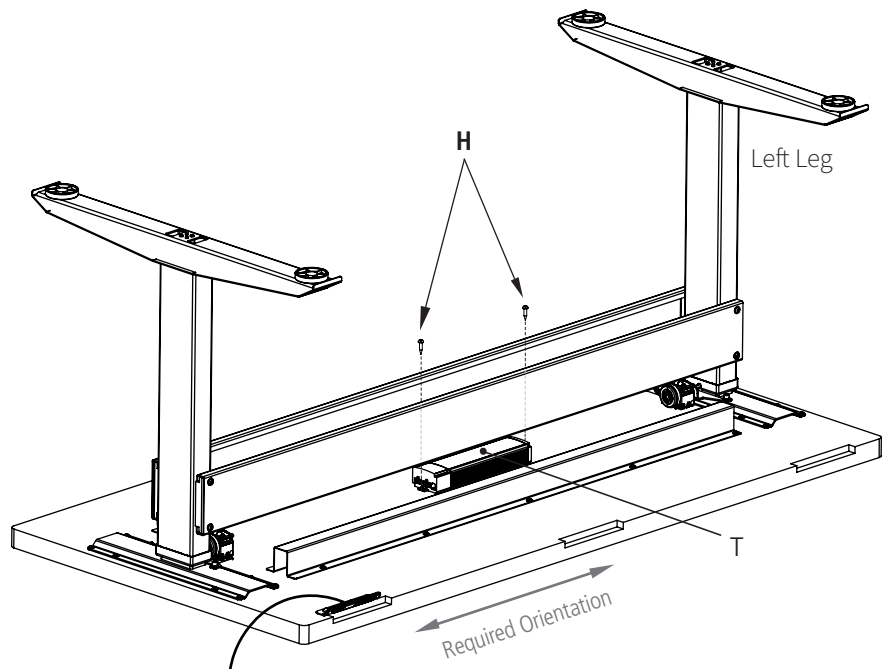
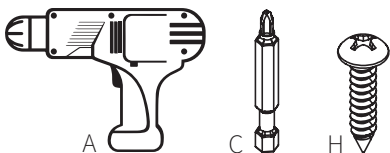

**NOTE:** Table will **NOT** operate unless the control box housing (T) is screwed tight into the table without any play.

## Step 11

- Install wire management channel (L) and cord clip (I) to organize the cords and cables with washer head wood screws (E).
- Pilot holes are not provided.
- See **cable mounting diagram** on next page for help.

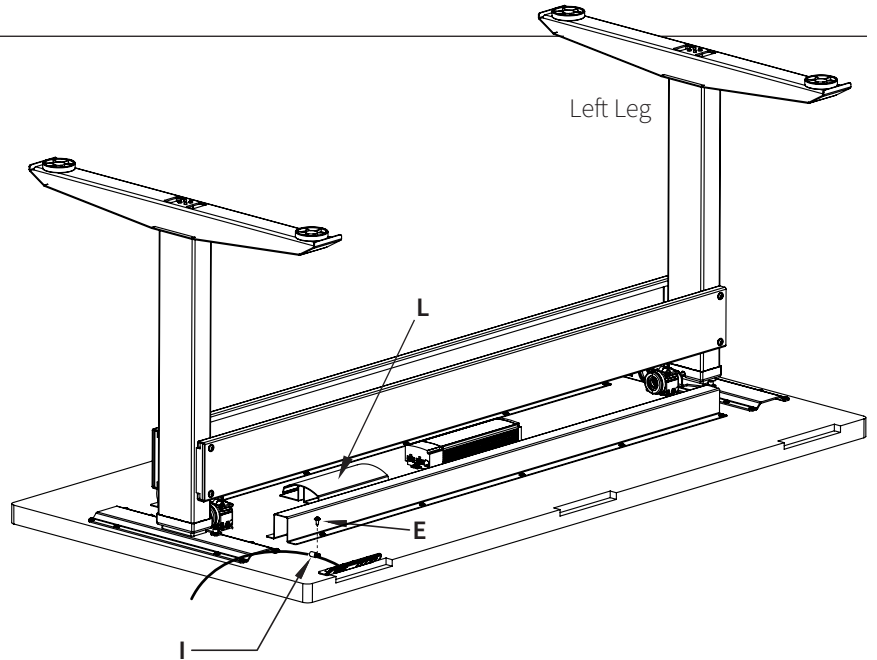
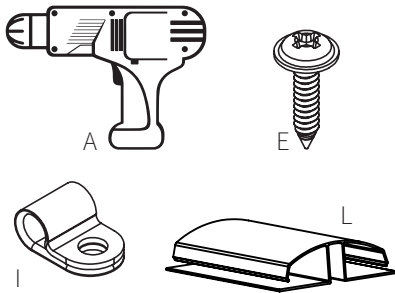

Mount the wire management channel (L) with adhesive strips AND two wood screws (E). Insert one screw on flat edge of each side of the wire management channel to penetrate plastic and worksurface.

## Step 12

- Plug the control switch (S) and motors (V & W) into the control box housing (T).
- Before inserting the control box battery pack (U), please follow the separate Battery Pack Instructions that were located the box containing the control box and battery pack.



Have casters or accessories to add? Install them while before you flip your BenchBUD right-side up to make the process easier.

### Control Box End View

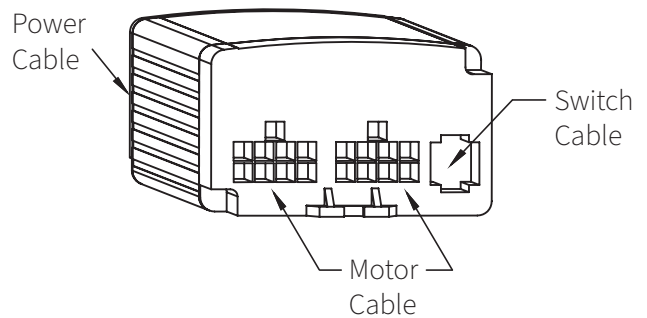

To install BenchBUD casters, follow the provided instruction sin the caster hardware pack or visit [benchbud.com/pages/installation](http://benchbud.com/pages/installation).

## Cable Routing Diagram

\*For tables 48" or smaller, the wire management can be moved.

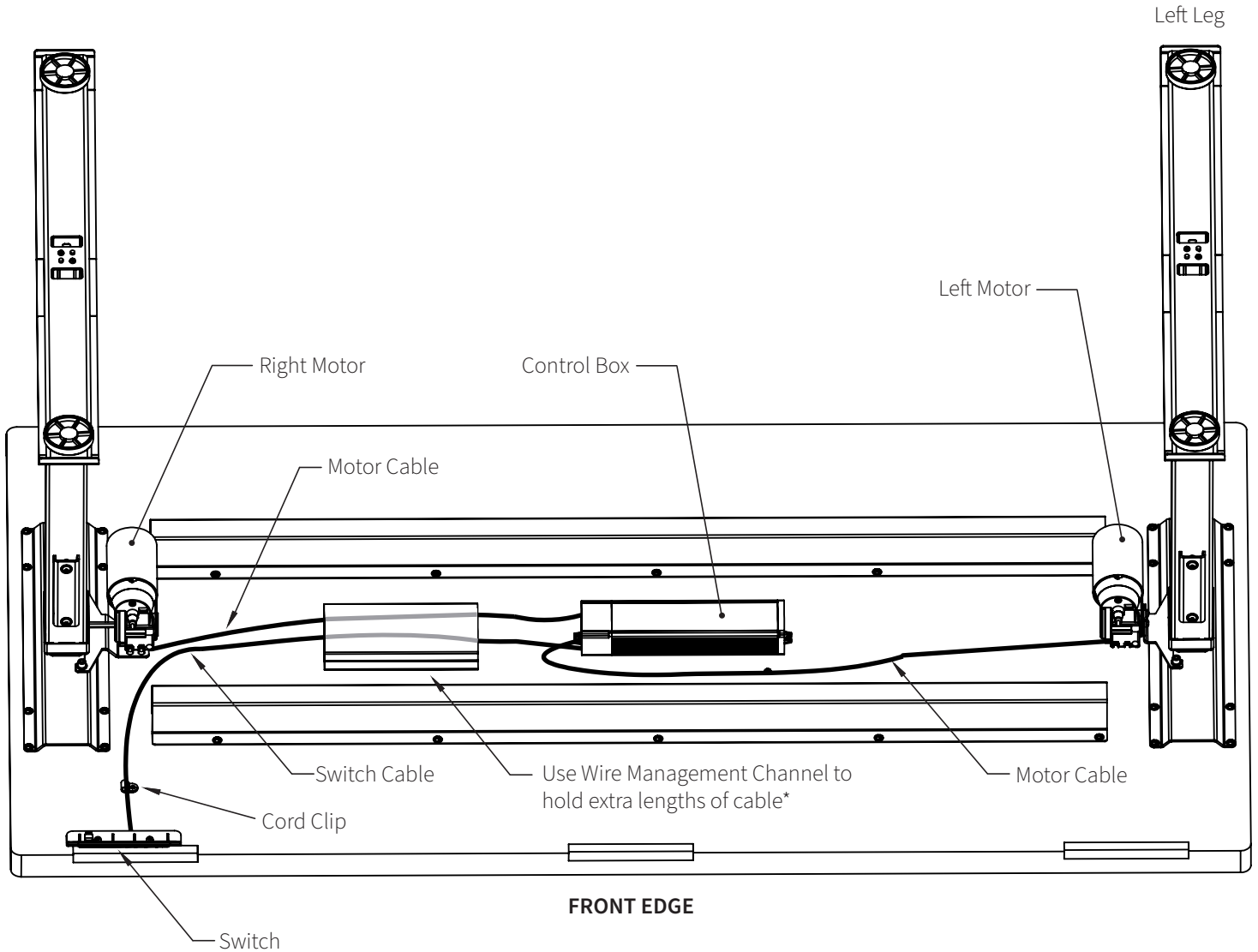

## Caution:



For the safety of the user and the workstation; the control box contains an internal sensor that is sensitive to movement, vibration, and collision. For faultless operation, ensure all cables, electronics, and accessories are cable managed and secured. Excessive load or weight must be distributed evenly. Failure to follow these guidelines may cause intermittent functionality.

# Bench**BUD**

Adjusts to All Users & Projects in Seconds

## Workbench Assembly Instructions

### BASE ONLY

If you purchased only the **BenchBUD base** and are using your **own worksurface**, begin here to follow instructions (pages 12- 20).

#### **SEE PAGE 13 FOR MAXIMUM WORKSURFACE SIZES**

Reference pages 21 - 22 for switch programming, connecting to mobile app, and mechanical reset mode instructions.

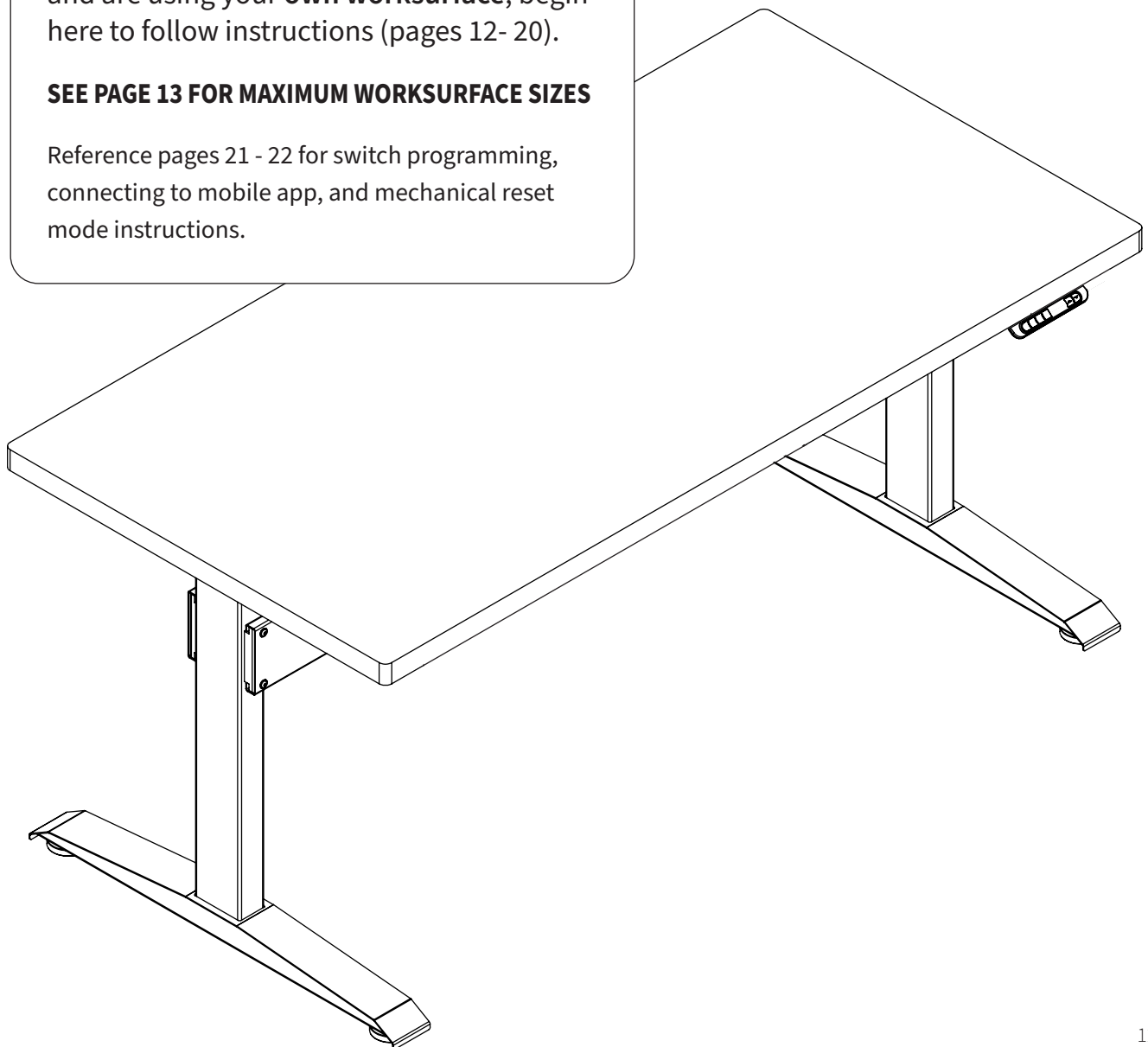

## Tools Required for Assembly

- A. Power Driver with Adjustable Torque
- B. Tape Measure
- C. #2 Phillips Head Driver Bit
- D. #2 Square Head Drive Bit **(Recommended)**

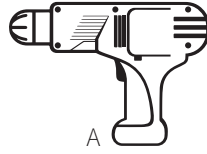

## Hardware and Tools Included for Assembly (may have extra)

- E. 5/8" Washer Head Wood Screw **x52**
- F. 1/4"x 5/8" Bolt **x4**
- G. Lock Washer **x4**
- H. 5/8" Wood Screw **x4**
- I. Cord Clip **x1**
- J. M6 x 10mm Bolt **x8**
- K. Star Washer **x8**
- L. Wire Management Channel **x1**
- M. 3/16" Allen Wrench **x1**
- N. 4mm Allen Wrench **x1**
- O. 6mm Hex Rod Wrench **x1**

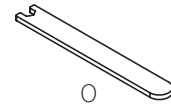
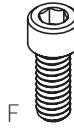

## BenchBUD Parts

- P. Cross Support **x2**
- Q. U-Channel **x2**
- R. Short Hex Rod **x2**
- S. Switch **x1**
- T. Control Box Housing **x1**
- U. Control Box Battery Pack **x1**
- V. Left Motor (ID#801064) **x1**
- W. Right Motor (ID#802136) **x1**
- X. Left Leg **x1**
- Y. Right Leg **x1**

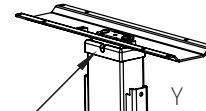
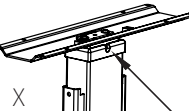
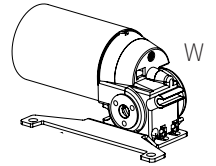
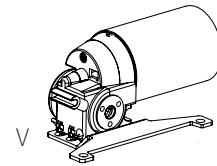
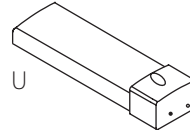
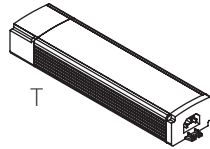
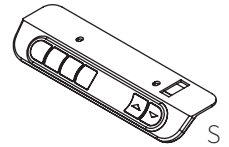
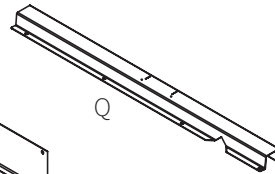
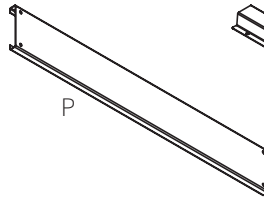

Note location of drive input hole.

Left Leg

Right Leg

### WORKSURFACE NOT INCLUDED



Maximum worksurface sizes compatible with BenchBUD bases:

BenchBUD Base	Max Worksurface
30" x 48"	30" x 72"
30" x 60"	30" x 84"
30" x 72"	30" x 96"



Legs must be in their **LOWEST** position before installation.

## Step 1



Use these instructions if you are assembling a BenchBUD base, but chose an alternate worksurface.

Lay your worksurface on a protected surface (with bottom facing up).

**LEGS MUST BE IN LOWEST POSITION BEFORE INSTALLING HEX RODS.**

- Place the **left leg column (X)** onto the worksurface (underside of worksurface should be facing up). Make sure leg is in its lowest position.
- Insert the short hex rod (R) through the **left motor assembly (V)** (insert starting at bracket side of the motor).
- Slide hex rod into left leg drive input hole. Hex rod should slide all the way into leg.
- If hex rod is not properly aligned with drive input, slightly rotate the motor 1/6th or 1/3rd of a turn.

**PRO TIP**

Hex Rod Wrench (O) can also be used to rotate hex rod

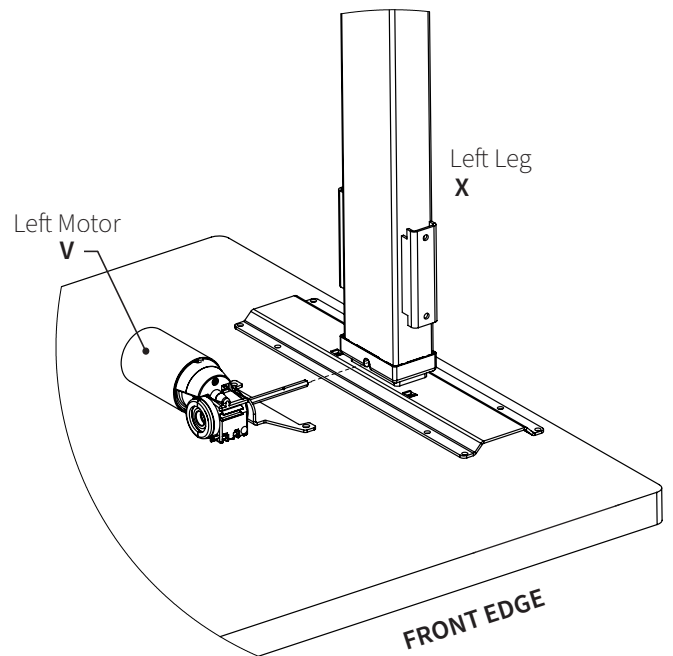
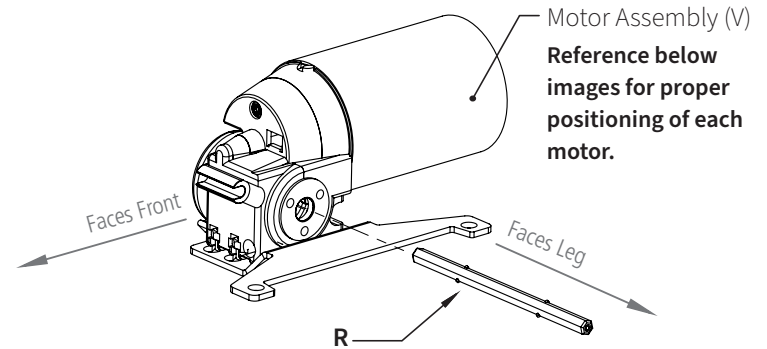
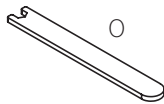

## Step 2

- Place the **right leg column (Y)** onto the worksurface. Make sure leg is in its lowest position.
- Insert the short hex rod (R) through the **right motor assembly (W)** (insert starting at bracket side of the motor).
- Slide hex rod into right leg drive input hole. Hex rod should slide all the way into leg.
- If hex rod is not properly aligned with drive input, slightly rotate the motor 1/6th or 1/3rd of a turn.

**PRO TIP**

Hex Rod Wrench (O) can also be used to rotate hex rod

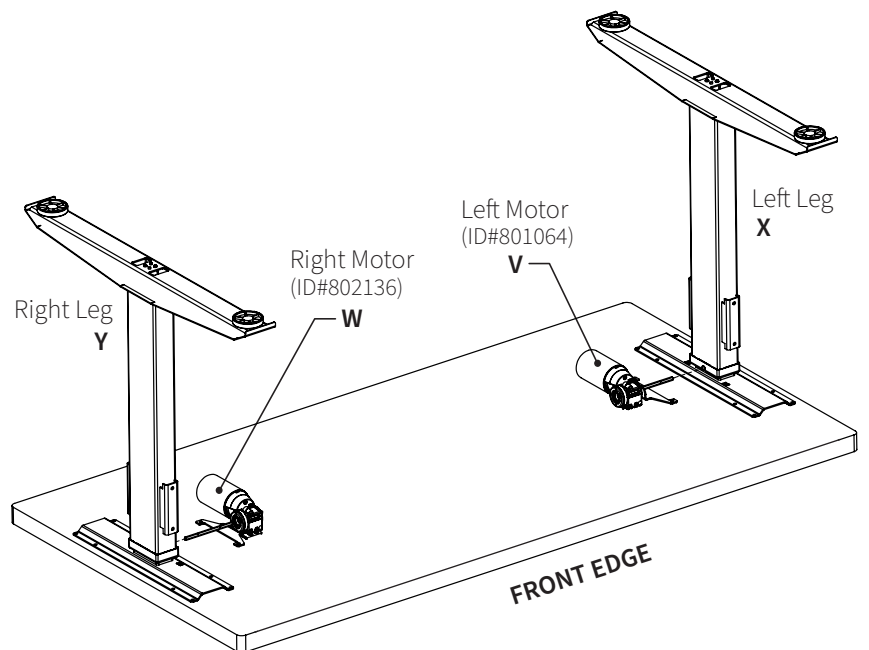
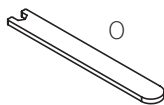

### Step 3

**Important:** Please be aware that 5/8" screws are provided. If your worksurface is 5/8" or thinner, you will need to supply your own hardware.

- After hex rods are installed, align **left motor bracket** and corresponding mounting holes on **left leg column (X)**.
- Position lock washers (G) and tighten motor mounting bolts (F).
- Repeat to attach **right motor bracket** to **right leg column (Y)**.

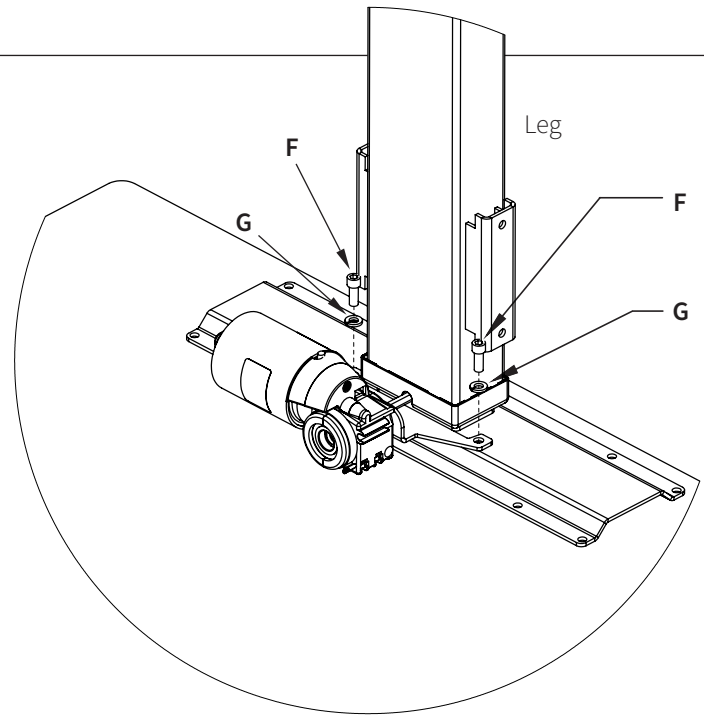

### Step 4

- Slide cross supports (P) over leg cross support brackets.

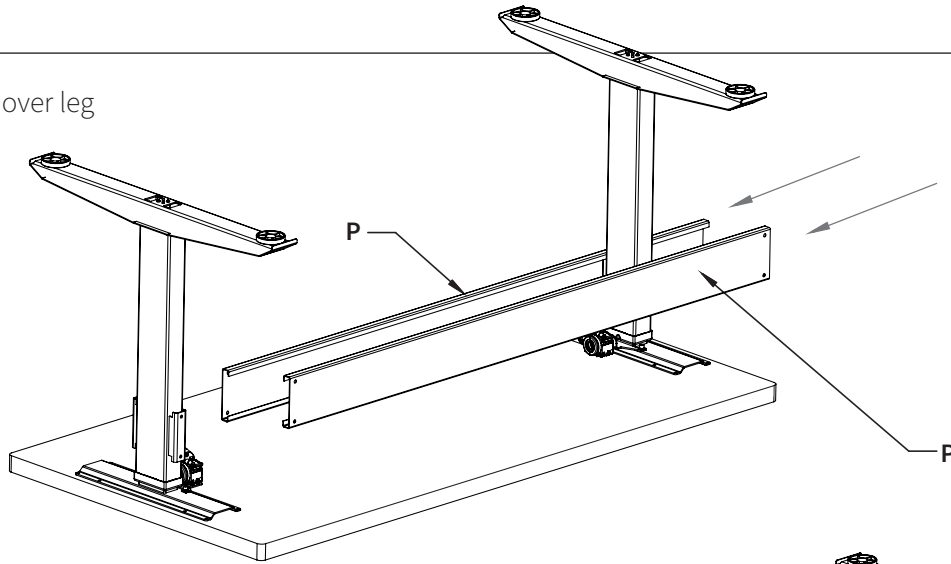

### Step 5

- Install bolts and washers (8 sets).  
**Fully tighten all the bolts.**

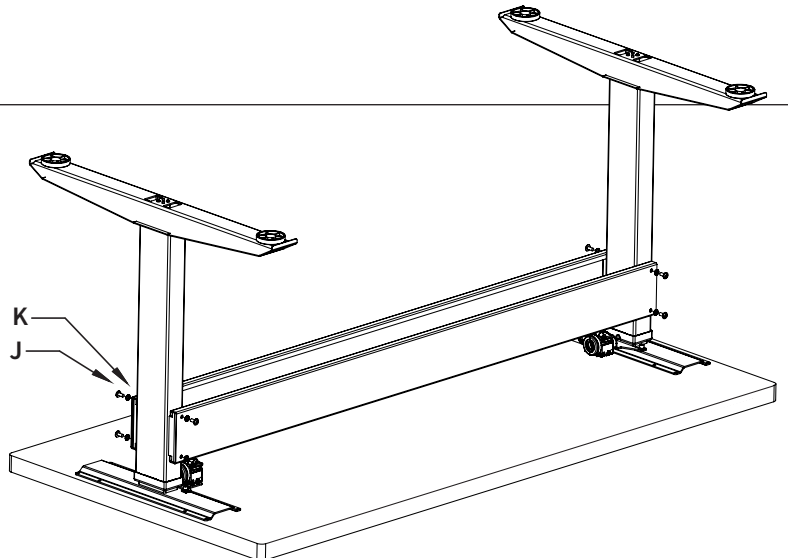
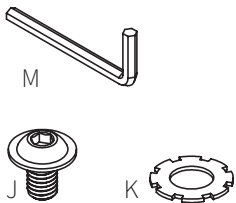

## Step 6

- Place assembled base on your worksurface.
- Before securing, measure to ensure the base is centered on the worksurface (both front-to-back and side-to-side).

**PRO TIP**

Reference the diagram below. To center side-to-side, all M1 widths must be the same. Each M1 width should not exceed 12". To center front-to-back, all M2 depths must be the same.

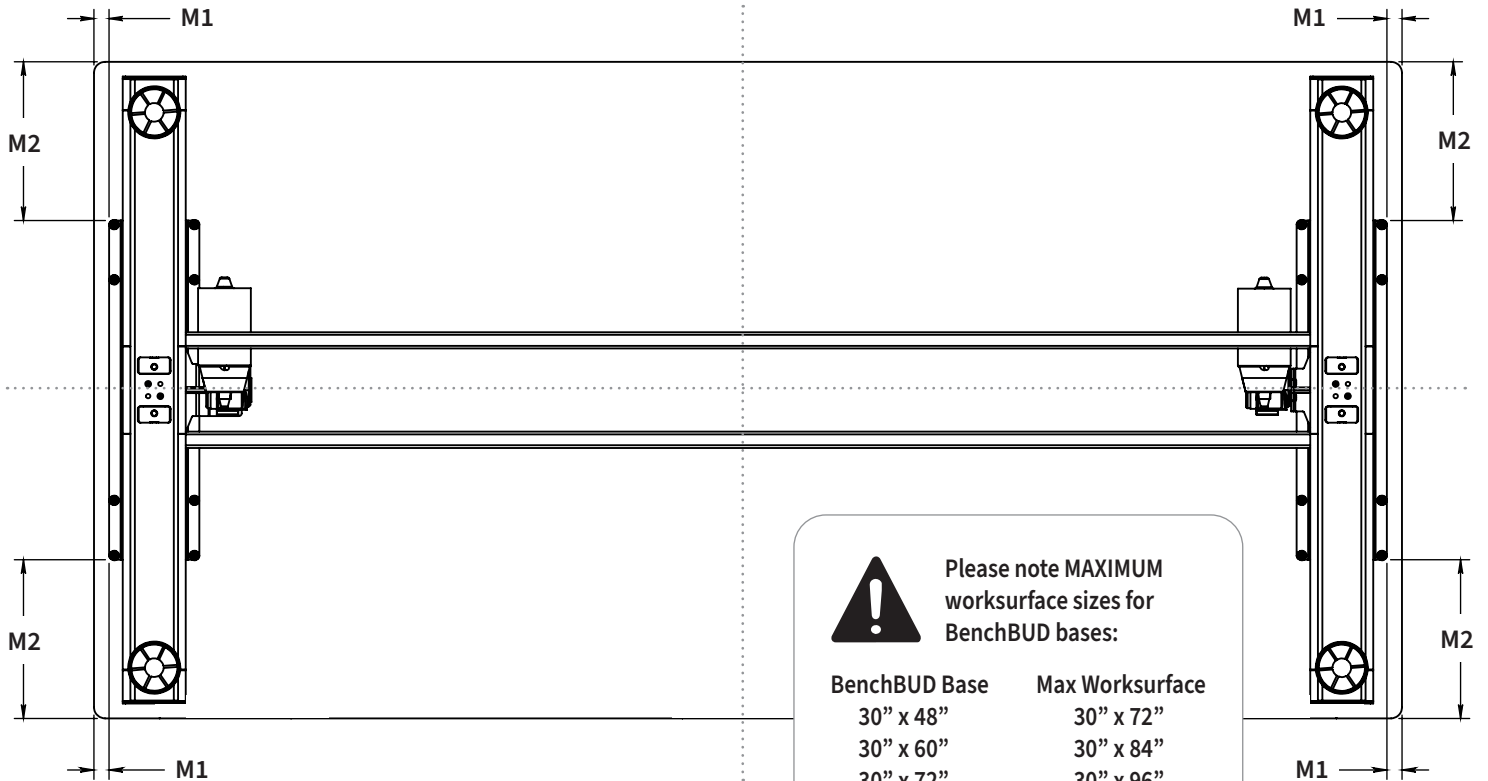

## Step 7

- Secure the base to the worksurface with washer head wood screws (E).
- **Do NOT fully tighten** until all wood screws are inserted.

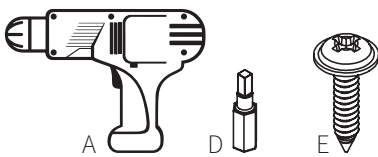

**PRO TIP**

For proper alignment, first insert screws at the four corners of each leg mounting bracket. Then, install remaining screws.

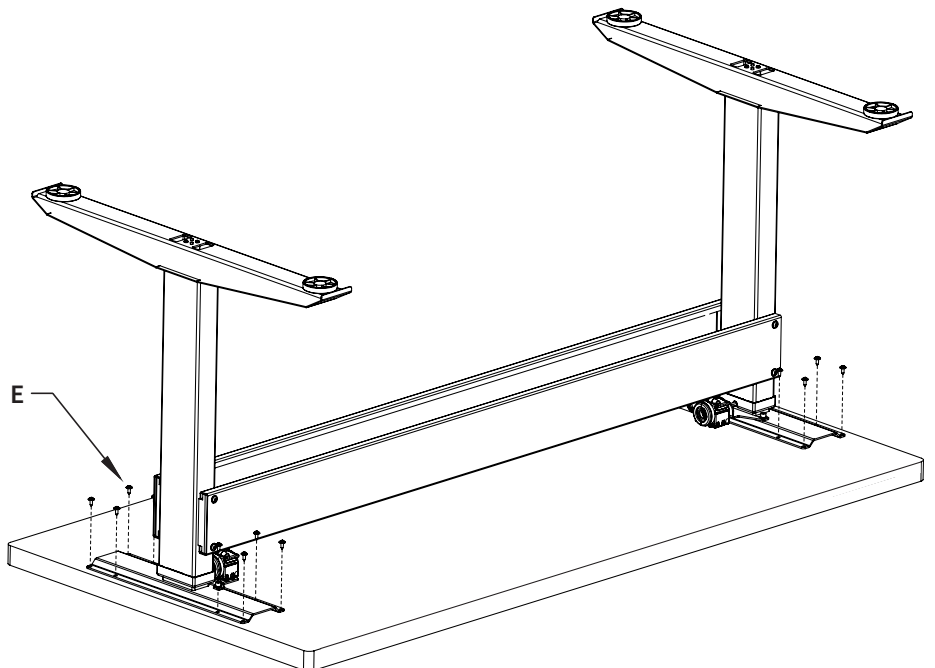



## Step 8

- Align the U-channels (Q) approximately 2" from each leg (from inside mount plate) and approximately 9.5" apart.



Reference the dotted lines in the diagram below. Align the each outside edge of the U-channel with the edge of the leg mount plates.

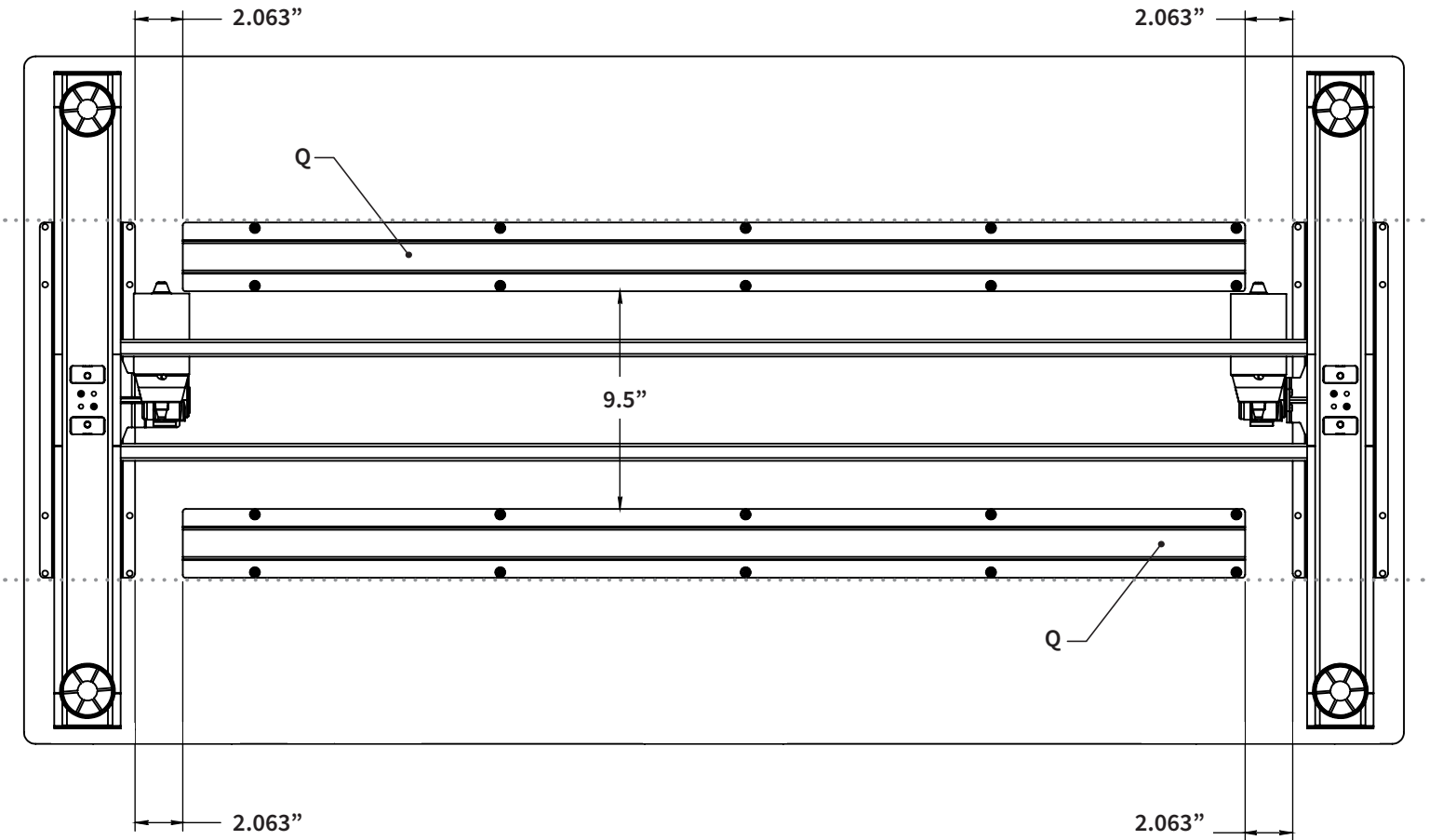

## Step 9

- Attach U-channel to worksurface with washer head wood screws (E).
- Do NOT fully tighten** until all screws are installed.

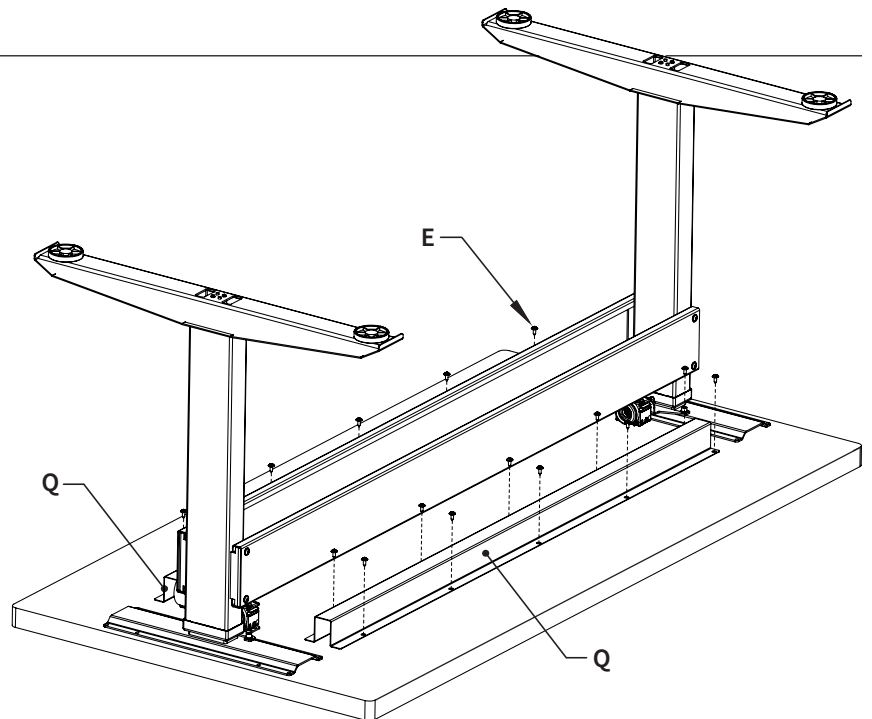
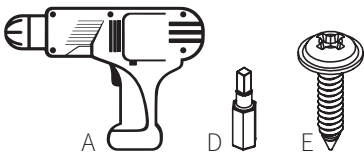

For proper alignment, first insert screws at the four corners of the U-channel. Then, install the remaining screws.

## Step 10

- Mount control switch (S) to worksurface using two wood screws (H).
- Switch can be installed in any location, wire lengths permitting.

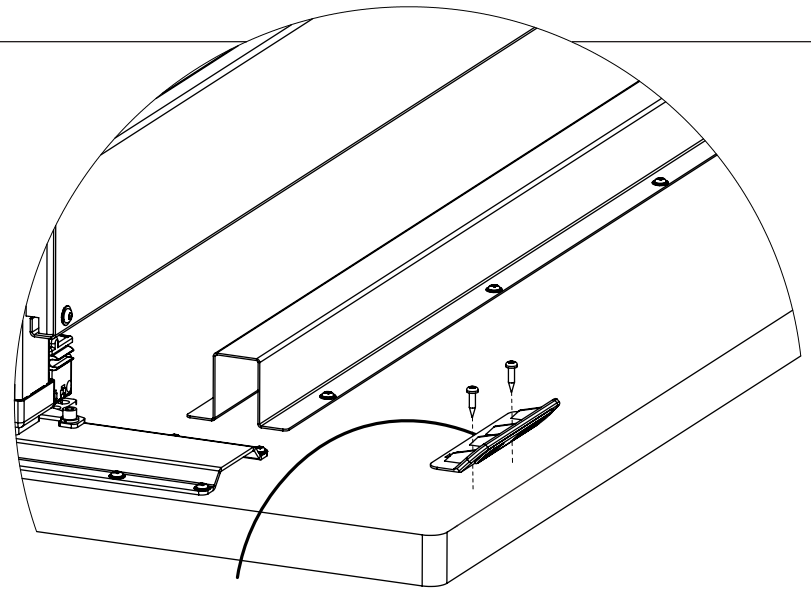
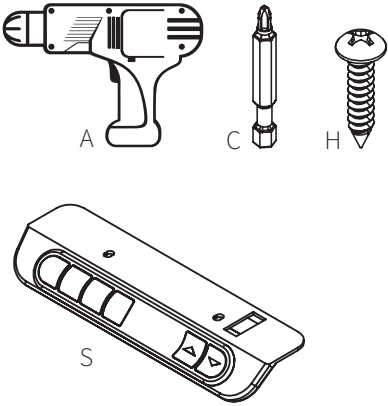

**NOTE:** Please refer to the installation instructions included with switch.

## Step 11

- Mount control box housing (T) to worksurface using two wood screws (H). The control box battery pack (U) cannot be inserted into the housing (T) yet.
- Control box can be installed in any location, wire lengths permitting.



**Required Orientation:**  
Long side of control box must run parallel to the long side of the worksurface.

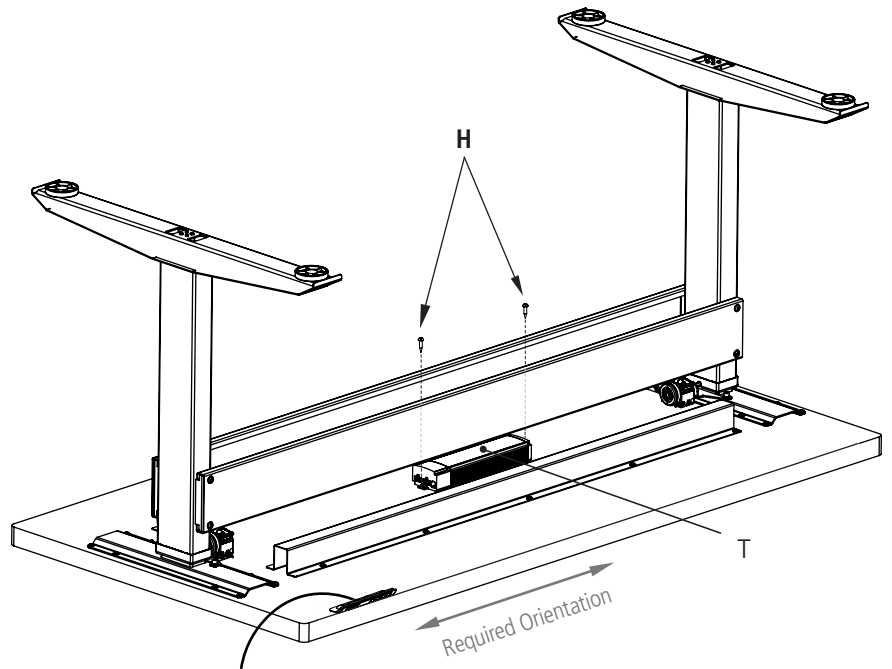
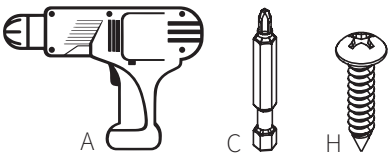

**NOTE:** Table will **NOT** operate unless the control box (T) is screwed tight into the table without any play.

## Step 12

- Install wire management channel (L) and cord clip (I) to organize the cords and cables with washer head wood screws (E).
- See **cable mounting diagram** on next page for help.

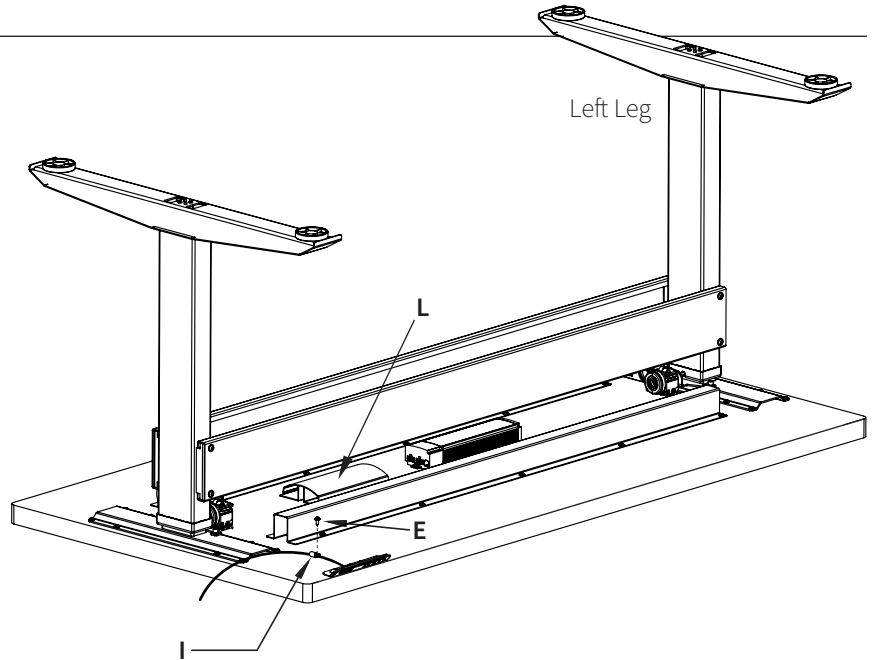
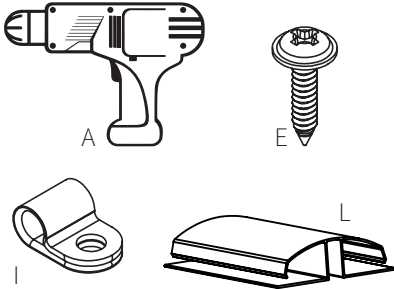

Mount the wire management channel (L) with adhesive strips AND two wood screws (E). Insert one screw on flat edge of each side of the wire management channel to penetrate plastic and worksurface.

## Step 13

- Plug the control switch (S) and motors (V & W) into the control box housing (T).
- Before inserting the control box battery pack (U), please follow the separate Battery Pack Instructions that were located the box containing the control box and battery pack.



Have casters or accessories to add? Install them while before you flip your BenchBUD right-side up to make the process easier.

### Control Box End View

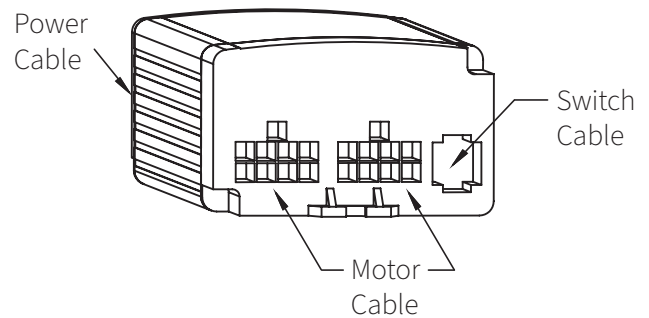

To install BenchBUD casters, follow the provided instruction sin the caster hardware pack or visit [benchbud.com/pages/installation](http://benchbud.com/pages/installation).

## Cable Routing Diagram

\*For tables 48" or smaller, the wire management can be moved.

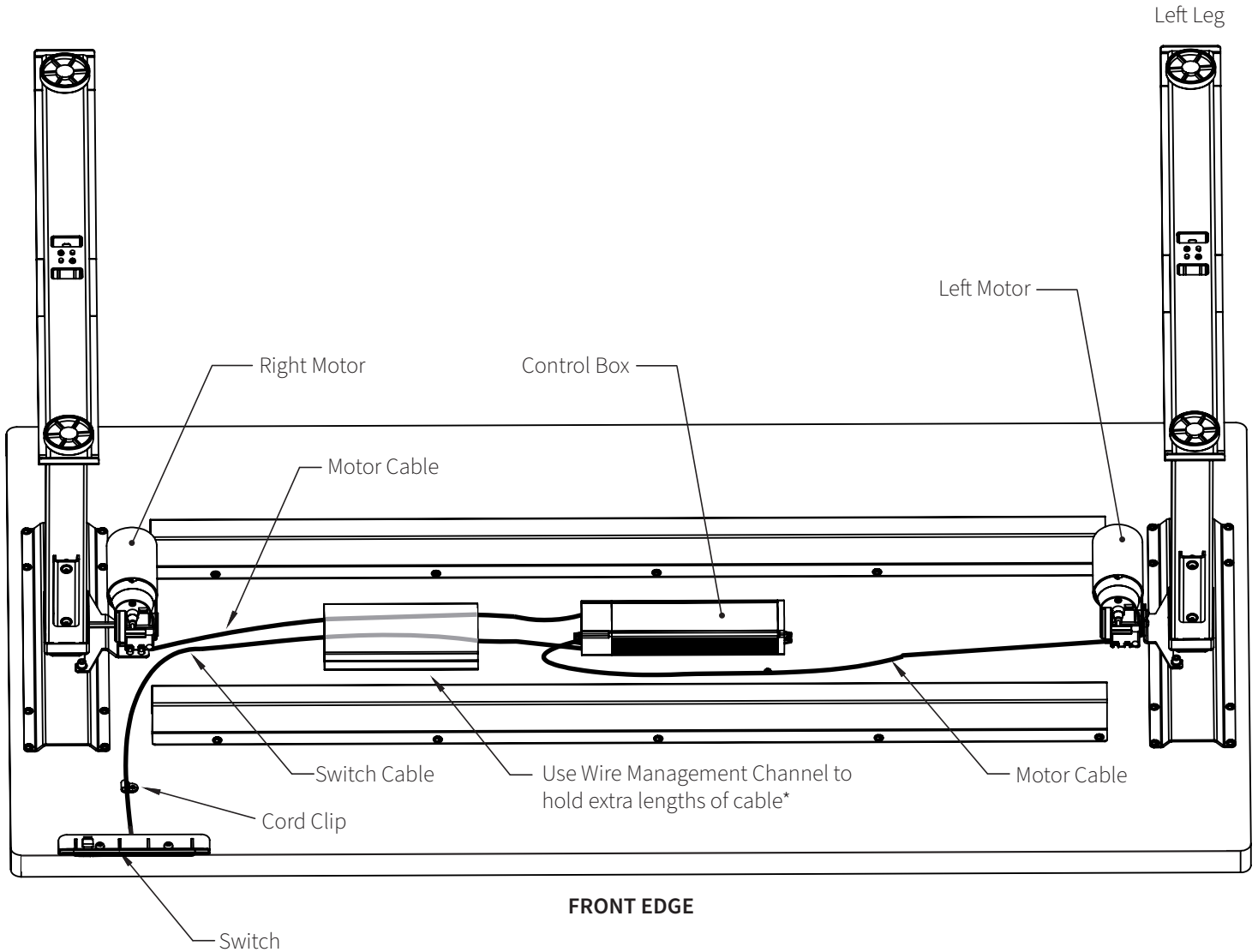

## Caution:



For the safety of the user and the workstation; the control box contains an internal sensor that is sensitive to movement, vibration, and collision. For faultless operation, ensure all cables, electronics, and accessories are cable managed and secured. Excessive load or weight must be distributed evenly. Failure to follow these guidelines may cause intermittent functionality.

## Note

---

If the leg assemblies are at uneven heights, it is usually caused by an improperly installed hex rod. Disassemble one of the leg assemblies from the worksurface and make sure both ends of the hex rod are properly engaged in the hex drives near the top of the leg assemblies.

## Programmable Switch (full instructions packaged with switch)

---

### Start Up Procedure (First Time Use):

- Before its first use, the battery pack must be activated and taken out of ship mode. To do so, plug the battery pack into the charger for at least a few seconds. It will now be activated, and you should see at least one LED light on the battery pack. While it is not required to fully charge the battery for first use, it is recommended.
- Insert the control box battery pack into the control box housing. The table is now on and in reset mode (will see 3 dashes on the control switch readout).
- Press the down arrow until the worksurface reaches its lowest position.
- The workstation is now ready for use.
- **If the table is not functioning normally, or if battery pack has been removed from the control box housing, perform the reset procedure.**

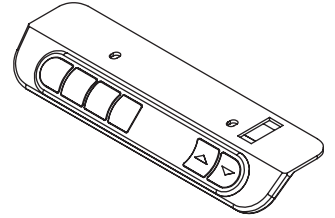

### Reset Procedure:

- Remove the battery pack from the control box housing for 30 seconds.
- Re-insert the battery pack into the control box housing.
- Clear all obstructions from the travel path of the workbench.
- Press and hold the down arrow key until the table reaches its lowest position. You may notice the table dip down and slightly rise at the end of the reset. This is completely normal. You may now resume normal table use.

---

### Troubleshooting:

If you are having any problems with the operation, contact BenchBUD at **715.903.3440** or **info@benchbud.com**.

## Mechanical Reset Mode

---

If the table is unresponsive, uneven, or not functioning properly, perform a manual reset.









**User settings are not reset in this process.**

There are three methods to reset a workstation:

### Reset Method A















1. Clear all obstructions from the travel path of the workstation.
2. Remove the battery pack from the control box housing for 30 seconds.
3. Re-insert the battery pack into the control box housing.
4. Press and hold the  until the workstation has reached its lowest possible position.

### Reset Method B (4 button programmable switch required)

1. Clear all obstructions from the travel path of the workstation
2. Quickly press  +  +  +  to enter the menu mode.
3. **POI** is displayed and you will hear a musical tone. 
4. Press the   to navigate the menu.
5. Navigate to the **PO9** display
6. Press the  button to enter or accept
7. Press and hold the  until the workstation has reached its lowest possible position.

The workstation is now ready to operate

### Reset Method C - 2 Button Switch

1. Clear all obstructions from the travel path of the workstation
2. Quickly press  +  +  +  to enter the menu mode.
3. You will hear a musical tone. 
4. Press  +  +  + 
5. You will reach the limit adjustment menu and hear four musical tones.    
6. Press and hold the  until the workstation has reached its lowest possible position.

The reference is re-calibrated, the table should be leveled and the height indication should be correct.